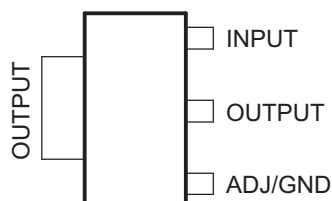
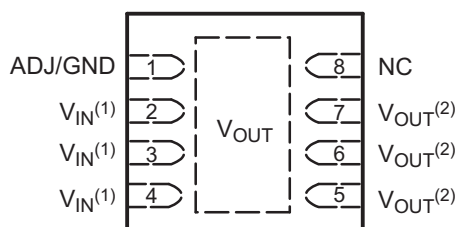

## ADJUSTABLE AND FIXED LOW-DROPOUT VOLTAGE REGULATOR

Check for Samples: [TLV1117](#)

### FEATURES

- 1.5-V, 1.8-V, 2.5-V, 3.3-V, 5-V, and Adjustable-Output Voltage Options
- Output Current of 800 mA
- Specified Dropout Voltage at Multiple Current Levels
- 0.2% Line Regulation Maximum
- 0.4% Load Regulation Maximum

**DCY (SOT-223) PACKAGE  
(TOP VIEW)**

**DRJ (QFN) PACKAGE  
(TOP VIEW)**

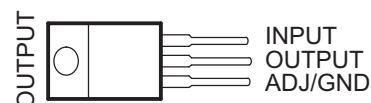
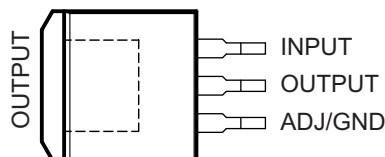
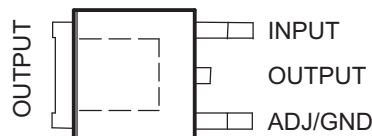
- (1)  $V_{IN}$  pins (2, 3, 4) must be connected together.  
(2)  $V_{OUT}$  pins (5, 6, 7) must be connected together.

**KCT / KCS (TO-220) PACKAGE  
(TOP VIEW)**

**KTT (TO-263) PACKAGE  
(TOP VIEW)**

**KVU (TO-252) PACKAGE  
(TOP VIEW)**

### DESCRIPTION/ORDERING INFORMATION

The TLV1117 is a positive low-dropout voltage regulator designed to provide up to 800 mA of output current. The device is available in 1.5-V, 1.8-V, 2.5-V, 3.3-V, 5-V, and adjustable-output voltage options. All internal circuitry is designed to operate down to 1-V input-to-output differential. Dropout voltage is specified at a maximum of 1.3 V at 800 mA, decreasing at lower load currents.

The TLV1117 is designed to be stable with tantalum and aluminum electrolytic output capacitors having an ESR between 0.2  $\Omega$  and 10  $\Omega$ .

Unlike pnp-type regulators, in which up to 10% of the output current is wasted as quiescent current, the quiescent current of the TLV1117 flows into the load, increasing efficiency.

The TLV1117C device is characterized for operation over the virtual junction temperature range of 0°C to 125°C, and the TLV1117I device is characterized for operation over the virtual junction temperature range of –40°C to 125°C.



Please be aware that an important notice concerning availability, standard warranty, and use in critical applications of Texas Instruments semiconductor products and disclaimers thereto appears at the end of this data sheet.



These devices have limited built-in ESD protection. The leads should be shorted together or the device placed in conductive foam during storage or handling to prevent electrostatic damage to the MOS gates.

### TLV1117C ORDERING INFORMATION<sup>(1)</sup>

T <sub>A</sub>	V <sub>O</sub> TYP	PACKAGE <sup>(2)</sup>		ORDERABLE PART NUMBER	TOP-SIDE MARKING
0°C to 125°C	1.5 V	QFN – DRJ	Reel of 1000	TLV1117-15CDRJR	ZYH
		SOT-223 – DCY	Tube of 80	TLV1117-15CDCY	T2
			Reel of 2500	TLV1117-15CDCYR	
	TO-252 – KVU	Reel of 2500	TLV1117-15CKVUR	ZE15	
	1.8 V	QFN – DRJ	Reel of 1000	TLV1117-18CDRJR	ZYK
		SOT-223 – DCY	Tube of 80	TLV1117-18CDCY	T4
			Reel of 2500	TLV1117-18CDCYR	
	TO-252 – KVU	Reel of 2500	TLV1117-18CKVUR	ZE18	
	2.5 V	QFN – DRJ	Reel of 1000	TLV1117-25CDRJR	ZYM
		SOT-223 – DCY	Tube of 80	TLV1117-25CDCY	T6
			Reel of 2500	TLV1117-25CDCYR	
	TO-252 – KVU	Reel of 2500	TLV1117-25CKVUR	ZE25	
	3.3 V	QFN – DRJ	Reel of 1000	TLV1117-33CDRJR	ZYP
		SOT-223 – DCY	Tube of 80	TLV1117-33CDCY	V3
			Reel of 2500	TLV1117-33CDCYR	
	TO-252 – KVU	Reel of 2500	TLV1117-33CKVUR	ZE33	
	5 V	QFN – DRJ	Reel of 1000	TLV1117-50CDRJR	ZE50
		SOT-223 – DCY	Tube of 80	TLV1117-50CDCY	VT
			Reel of 2500	TLV1117-50CDCYR	
	TO-252 – KVU	Reel of 2500	TLV1117-50CKVUR	ZE50	
	ADJ	QFN – DRJ	Reel of 1000	TLV1117CDRJR	ZYS
		SOT-223 – DCY	Tube of 80	TLV1117CDCY	V4
			Reel of 2500	TLV1117CDCYR	
		TO-220 – KCS	Tube of 50	TLV1117CKCS	TLV1117C
TO-220 – KCT		Tube of 50	TLV1117CKCT	TLV1117C	
TO-252 – KVU		Reel of 2500	TLV1117CKVUR	TV1117	
TO-263 – KTT	Reel of 500	TLV1117CKTTR	TLV1117C		

(1) For the most current package and ordering information, see the Package Option Addendum at the end of this document, or see the TI web site at [www.ti.com](http://www.ti.com).

(2) Package drawings, thermal data, and symbolization are available at [www.ti.com/packaging](http://www.ti.com/packaging).

**TLV1117I ORDERING INFORMATION<sup>(1)</sup>**

T <sub>A</sub>	V <sub>O</sub> TYP	PACKAGE <sup>(2)</sup>		ORDERABLE PART NUMBER	TOP-SIDE MARKING
-40°C to 125°C	1.5 V	QFN – DRJ	Reel of 1000	TLV1117-15IDRJR	ZYJ
		SOT-223 – DCY	Tube of 80	TLV1117-15IDCY	T3
			Reel of 2500	TLV1117-15IDCYR	
		TO-252 – KVU	Reel of 2500	TLV1117-15IKVUR	ZF15
	1.8 V	QFN – DRJ	Reel of 1000	TLV1117-18IDRJR	ZYL
		SOT-223 – DCY	Tube of 80	TLV1117-18IDCY	T5
			Reel of 2500	TLV1117-18IDCYR	
		TO-252 – KVU	Reel of 2500	TLV1117-18IKVUR	ZF18
	2.5 V	QFN – DRJ	Reel of 1000	TLV1117-25IDRJR	ZYN
		SOT-223 – DCY	Tube of 80	TLV1117-25IDCY	T8
			Reel of 2500	TLV1117-25IDCYR	
		TO-252 – KVU	Reel of 2500	TLV1117-25IKVUR	ZF25
	3.3 V	QFN – DRJ	Reel of 1000	TLV1117-33IDRJR	ZYR
		SOT-223 – DCY	Tube of 80	TLV1117-33IDCY	VS
			Reel of 2500	TLV1117-33IDCYR	
		TO-252 – KVU	Reel of 2500	TLV1117-33IKVUR	ZF33
	5 V	QFN – DRJ	Reel of 1000	TLV1117-50IDRJR	ZF50
		SOT-223 – DCY	Tube of 80	TLV1117-50IDCY	VU
			Reel of 2500	TLV1117-50IDCYR	
		TO-252 – KVU	Reel of 2500	TLV1117-50IKVUR	ZF50
	ADJ	QFN – DRJ	Reel of 1000	TLV1117IDRJR	ZYT
SOT-223 – DCY		Tube of 80	TLV1117IDCY	V2	
		Reel of 2500	TLV1117IDCYR		
TO-220 – KCS		Tube of 50	TLV1117IKCS	TLV1117I	
TO-252 – KVU		Reel of 2500	TLV1117IKVUR	TY1117	
TO-263 – KTT	Reel of 500	TLV1117IKTTR	TLV1117I		

(1) For the most current package and ordering information, see the Package Option Addendum at the end of this document, or see the TI web site at [www.ti.com](http://www.ti.com).

(2) Package drawings, thermal data, and symbolization are available at [www.ti.com/packaging](http://www.ti.com/packaging).

**FUNCTIONAL BLOCK DIAGRAM**

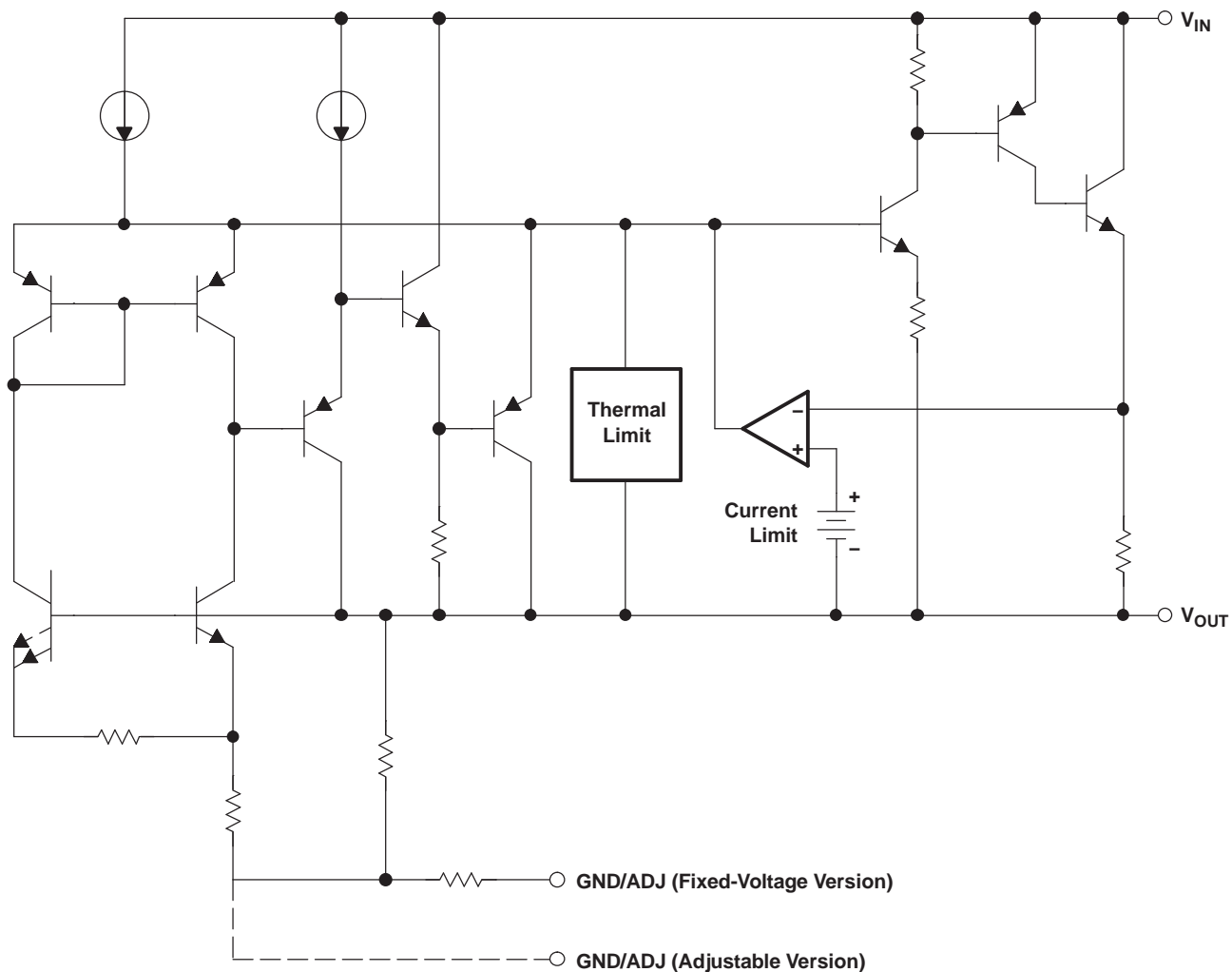

## ABSOLUTE MAXIMUM RATINGS<sup>(1)</sup>

over operating free-air temperature range (unless otherwise noted)

		MIN	MAX	UNIT
V <sub>IN</sub>	Continuous input voltage		16	V
T <sub>J</sub>	Operating virtual-junction temperature		150	°C
T <sub>stg</sub>	Storage temperature range	–65	150	°C

- (1) Stresses beyond those listed under "absolute maximum ratings" may cause permanent damage to the device. These are stress ratings only, and functional operation of the device at these or any other conditions beyond those indicated under "recommended operating conditions" is not implied. Exposure to absolute-maximum-rated conditions for extended periods may affect device reliability.

## THERMAL INFORMATION

THERMAL METRIC <sup>(1)(2)(3)</sup>	TLV1117							UNITS	
	PowerFlex		DRJ (8 PINS)	DCY (4 PINS)	KVU (3 PINS)	KCS/KCT (3 PINS)	KTT (3 PINS)		
	KTE (3 PINS)	KTP (3 PINS)							
θ <sub>JA</sub>	Junction-to-ambient thermal resistance	38.6	49.2	38.3	104.3	50.9	30.1	27.5	°C/W
θ <sub>JCtop</sub>	Junction-to-case (top) thermal resistance	34.7	60.6	36.5	53.7	57.9	44.6	43.2	
θ <sub>JB</sub>	Junction-to-board thermal resistance	3.2	3.1	60.5	5.7	34.8	1.2	17.3	
ψ <sub>JT</sub>	Junction-to-top characterization parameter	5.9	8.7	0.2	3.1	6	5	2.8	
ψ <sub>JB</sub>	Junction-to-board characterization parameter	3.1	3	12	5.5	23.7	1.2	9.3	
θ <sub>JCbot</sub>	Junction-to-case (bottom) thermal resistance	3	3	4.7	n/a	0.4	0.4	0.3	
θ <sub>JP</sub>	Thermal resistance between the die junction and the bottom of the exposed pad.	2.7	1.4	1.78	n/a	n/a	3	1.94	

- (1) For more information about traditional and new thermal metrics, see the *IC Package Thermal Metrics* application report, [SPRA953](#).  
 (2) For thermal estimates of this device based on PCB copper area, see the [TI PCB Thermal Calculator](#).  
 (3) Maximum power dissipation is a function of T<sub>J(max)</sub>, θ<sub>JA</sub>, and T<sub>A</sub>. The maximum allowable power dissipation at any allowable ambient temperature is P<sub>D</sub> = (T<sub>J(max)</sub> – T<sub>A</sub>)/θ<sub>JA</sub>. Operating at the absolute maximum T<sub>J</sub> of 150°C can affect reliability.

## RECOMMENDED OPERATING CONDITIONS

		MIN <sup>(1)</sup>	MAX	UNIT	
V <sub>IN</sub>	Input voltage	TLV1117	2.7	15	V
		TLV1117-15	2.9	15	
		TLV1117-18	3.2	15	
		TLV1117-25	3.9	15	
		TLV1117-33	4.7	15	
		TLV1117-50	6.4	15	
I <sub>O</sub>	Output current		0.8	A	
T <sub>J</sub>	Operating virtual-junction temperature	TLV1117C	0	125	°C
		TLV1117I	–40	125	

- (1) The input-to-output differential across the regulator should provide for some margin against regulator operation at the maximum dropout (for a particular current value). This margin is needed to account for tolerances in both the input voltage (lower limit) and the output voltage (upper limit). The absolute minimum V<sub>IN</sub> for a desired maximum output current can be calculated by the following:

$$V_{IN(min)} = V_{OUT(max)} + V_{DO(max \text{ at rated current})}$$

## TLV1117C ELECTRICAL CHARACTERISTICS

$T_J = 0^\circ\text{C}$  to  $125^\circ\text{C}$ , all typical values are at  $T_J = 25^\circ\text{C}$  (unless otherwise noted)

PARAMETER	TEST CONDITIONS <sup>(1)</sup>		MIN	TYP	MAX	UNIT	
Reference voltage, $V_{REF}$	$V_{IN} - V_{OUT} = 2\text{ V}$ , $I_{OUT} = 10\text{ mA}$ , $T_J = 25^\circ\text{C}$	TLV1117	1.238	1.25	1.262	V	
	$V_{IN} - V_{OUT} = 1.4\text{ V}$ to $10\text{ V}$ , $I_{OUT} = 10\text{ mA}$ to $800\text{ mA}$		1.225	1.25	1.27		
Output voltage, $V_{OUT}$	$V_{IN} = 3.5\text{ V}$ , $I_{OUT} = 10\text{ mA}$ , $T_J = 25^\circ\text{C}$	TLV1117-15	1.485	1.5	1.515		
	$V_{IN} = 2.9\text{ V}$ to $10\text{ V}$ , $I_{OUT} = 0$ to $800\text{ mA}$		1.455	1.5	1.545		
	$V_{IN} = 3.8\text{ V}$ , $I_{OUT} = 10\text{ mA}$ , $T_J = 25^\circ\text{C}$	TLV1117-18	1.782	1.8	1.818		
	$V_{IN} = 3.2\text{ V}$ to $10\text{ V}$ , $I_{OUT} = 0$ to $800\text{ mA}$		1.746	1.8	1.854		
	$V_{IN} = 4.5\text{ V}$ , $I_{OUT} = 10\text{ mA}$ , $T_J = 25^\circ\text{C}$	TLV1117-25	2.475	2.5	2.525		
	$V_{IN} = 3.9\text{ V}$ to $10\text{ V}$ , $I_{OUT} = 0$ to $800\text{ mA}$		2.450	2.5	2.550		
	$V_{IN} = 5\text{ V}$ , $I_{OUT} = 10\text{ mA}$ , $T_J = 25^\circ\text{C}$	TLV1117-33	3.267	3.3	3.333		
	$V_{IN} = 4.75\text{ V}$ to $10\text{ V}$ , $I_{OUT} = 0$ to $800\text{ mA}$		3.235	3.3	3.365		
	$V_{IN} = 7\text{ V}$ , $I_{OUT} = 10\text{ mA}$ , $T_J = 25^\circ\text{C}$	TLV1117-50	4.950	5.0	5.050		
	$V_{IN} = 6.5\text{ V}$ to $12\text{ V}$ , $I_{OUT} = 0$ to $800\text{ mA}$		4.900	5.0	5.100		
Line regulation	$I_{OUT} = 10\text{ mA}$ , $V_{IN} - V_{OUT} = 1.5\text{ V}$ to $13.75\text{ V}$	TLV1117		0.035	0.2		%
	$I_{OUT} = 0\text{ mA}$ , $V_{IN} = 2.9\text{ V}$ to $10\text{ V}$	TLV1117-15		1	6		
	$I_{OUT} = 0\text{ mA}$ , $V_{IN} = 3.2\text{ V}$ to $10\text{ V}$	TLV1117-18		1	6		
	$I_{OUT} = 0\text{ mA}$ , $V_{IN} = 3.9\text{ V}$ to $10\text{ V}$	TLV1117-25		1	6		
	$I_{OUT} = 0\text{ mA}$ , $V_{IN} = 4.75\text{ V}$ to $15\text{ V}$	TLV1117-33		1	6		
	$I_{OUT} = 0\text{ mA}$ , $V_{IN} = 6.5\text{ V}$ to $15\text{ V}$	TLV1117-50		1	10		
Load regulation	$I_{OUT} = 10\text{ mA}$ to $800\text{ mA}$ , $V_{IN} - V_{OUT} = 3\text{ V}$	TLV1117		0.2	0.4	%	
	$I_{OUT} = 0$ to $800\text{ mA}$ , $V_{IN} = 2.9\text{ V}$	TLV1117-15		1	10		
	$I_{OUT} = 0$ to $800\text{ mA}$ , $V_{IN} = 3.2\text{ V}$	TLV1117-18		1	10		
	$I_{OUT} = 0$ to $800\text{ mA}$ , $V_{IN} = 3.9\text{ V}$	TLV1117-25		1	10		
	$I_{OUT} = 0$ to $800\text{ mA}$ , $V_{IN} = 4.75\text{ V}$	TLV1117-33		1	10		
	$I_{OUT} = 0$ to $800\text{ mA}$ , $V_{IN} = 6.5\text{ V}$	TLV1117-50		1	15		
Dropout voltage, $V_{DO}$ <sup>(2)</sup>	$I_{OUT} = 100\text{ mA}$			1.1	1.2	V	
	$I_{OUT} = 500\text{ mA}$			1.15	1.25		
	$I_{OUT} = 800\text{ mA}$			1.2	1.3		
Current limit	$V_{IN} - V_{OUT} = 5\text{ V}$ , $T_J = 25^\circ\text{C}$ <sup>(3)</sup>		0.8	1.2	1.6	A	
Minimum load current	$V_{IN} = 15\text{ V}$	TLV1117		1.7	5	mA	
Quiescent current	$V_{IN} \leq 15\text{ V}$	All fixed-voltage options		5	10	mA	
Thermal regulation	30-ms pulse, $T_A = 25^\circ\text{C}$			0.01	0.1	%/W	
Ripple rejection	$V_{IN} - V_{OUT} = 3\text{ V}$ , $V_{ripple} = 1\text{ V}_{pp}$ , $f = 120\text{ Hz}$		60	75		dB	
ADJ pin current				80	120	$\mu\text{A}$	
Change in ADJ pin current	$V_{IN} - V_{OUT} = 1.4\text{ V}$ to $10\text{ V}$ , $I_{OUT} = 10\text{ mA}$ to $800\text{ mA}$			0.2	5	$\mu\text{A}$	
Temperature stability	$T_J = \text{full range}$			0.5		%	
Long-term stability	1000 hrs, No load, $T_A = 125^\circ\text{C}$			0.3		%	
Output noise voltage (% of $V_{OUT}$ )	$f = 10\text{ Hz}$ to $100\text{ kHz}$			0.003		%	

- (1) All characteristics are measured with a  $10\text{-}\mu\text{F}$  capacitor across the input and a  $10\text{-}\mu\text{F}$  capacitor across the output. Pulse testing techniques are used to maintain the junction temperature as close to the ambient temperature as possible.
- (2) Dropout is defined as the  $V_{IN}$  to  $V_{OUT}$  differential at which  $V_{OUT}$  drops  $100\text{ mV}$  below the value of  $V_{OUT}$ , measured at  $V_{IN} = V_{OUT(nom)} + 1.5\text{ V}$ .
- (3) Current limit test specified under recommended operating conditions

**TLV1117I ELECTRICAL CHARACTERISTICS**
 $T_J = -40^{\circ}\text{C}$  to  $125^{\circ}\text{C}$ , all typical values are at  $T_J = 25^{\circ}\text{C}$  (unless otherwise noted)

PARAMETER	TEST CONDITIONS <sup>(1)</sup>	MIN	TYP	MAX	UNIT	
Reference voltage, $V_{REF}$	$V_{IN} - V_{OUT} = 2\text{ V}$ , $I_{OUT} = 10\text{ mA}$ , $T_J = 25^{\circ}\text{C}$	1.238	1.25	1.262	V	
	$V_{IN} - V_{OUT} = 1.4\text{ V}$ to $10\text{ V}$ , $I_{OUT} = 10\text{ mA}$ to $800\text{ mA}$	1.200	1.25	1.29		
Output voltage, $V_{OUT}$	$V_{IN} = 3.5\text{ V}$ , $I_{OUT} = 10\text{ mA}$ , $T_J = 25^{\circ}\text{C}$	1.485	1.5	1.515		
	$V_{IN} = 2.9\text{ V}$ to $10\text{ V}$ , $I_{OUT} = 0$ to $800\text{ mA}$	1.44	1.5	1.56		
	$V_{IN} = 3.8\text{ V}$ , $I_{OUT} = 10\text{ mA}$ , $T_J = 25^{\circ}\text{C}$	1.782	1.8	1.818		
	$V_{IN} = 3.2\text{ V}$ to $10\text{ V}$ , $I_{OUT} = 0$ to $800\text{ mA}$	1.728	1.8	1.872		
	$V_{IN} = 4.5\text{ V}$ , $I_{OUT} = 10\text{ mA}$ , $T_J = 25^{\circ}\text{C}$	2.475	2.5	2.525		
	$V_{IN} = 3.9\text{ V}$ to $10\text{ V}$ , $I_{OUT} = 0$ to $800\text{ mA}$	2.4	2.5	2.6		
	$V_{IN} = 5\text{ V}$ , $I_{OUT} = 10\text{ mA}$ , $T_J = 25^{\circ}\text{C}$	3.267	3.3	3.333		
	$V_{IN} = 4.75\text{ V}$ to $10\text{ V}$ , $I_{OUT} = 0$ to $800\text{ mA}$	3.168	3.3	3.432		
	$V_{IN} = 7\text{ V}$ , $I_{OUT} = 10\text{ mA}$ , $T_J = 25^{\circ}\text{C}$	4.95	5.0	5.05		
	$V_{IN} = 6.5\text{ V}$ to $12\text{ V}$ , $I_{OUT} = 0$ to $800\text{ mA}$	4.80	5.0	5.20		
Line regulation	$I_{OUT} = 10\text{ mA}$ , $V_{IN} - V_{OUT} = 1.5\text{ V}$ to $13.75\text{ V}$		0.035	0.3		%
	$I_{OUT} = 0\text{ mA}$ , $V_{IN} = 2.9\text{ V}$ to $10\text{ V}$		1	10		mV
	$I_{OUT} = 0\text{ mA}$ , $V_{IN} = 3.2\text{ V}$ to $10\text{ V}$		1	10		
	$I_{OUT} = 0\text{ mA}$ , $V_{IN} = 3.9\text{ V}$ to $10\text{ V}$		1	10		
	$I_{OUT} = 0\text{ mA}$ , $V_{IN} = 4.75\text{ V}$ to $15\text{ V}$		1	10		
	$I_{OUT} = 0\text{ mA}$ , $V_{IN} = 6.5\text{ V}$ to $15\text{ V}$		1	15		
Load regulation	$I_{OUT} = 10\text{ mA}$ to $800\text{ mA}$ , $V_{IN} - V_{OUT} = 3\text{ V}$		0.2	0.5	%	
	$I_{OUT} = 0$ to $800\text{ mA}$ , $V_{IN} = 2.9\text{ V}$		1	15	mV	
	$I_{OUT} = 0$ to $800\text{ mA}$ , $V_{IN} = 3.2\text{ V}$		1	15		
	$I_{OUT} = 0$ to $800\text{ mA}$ , $V_{IN} = 3.9\text{ V}$		1	15		
	$I_{OUT} = 0$ to $800\text{ mA}$ , $V_{IN} = 4.75\text{ V}$		1	15		
	$I_{OUT} = 0$ to $800\text{ mA}$ , $V_{IN} = 6.5\text{ V}$		1	20		
Dropout voltage, $V_{DO}$ <sup>(2)</sup>	$I_{OUT} = 100\text{ mA}$		1.1	1.3	V	
	$I_{OUT} = 500\text{ mA}$		1.15	1.35		
	$I_{OUT} = 800\text{ mA}$		1.2	1.4		
Current limit	$V_{IN} - V_{OUT} = 5\text{ V}$ , $T_J = 25^{\circ}\text{C}$ <sup>(3)</sup>	0.8	1.2	1.6	A	
Minimum load current	$V_{IN} = 15\text{ V}$		1.7	5	mA	
Quiescent current	$V_{IN} \leq 15\text{ V}$		5	15	mA	
Thermal regulation	30-ms pulse, $T_A = 25^{\circ}\text{C}$		0.01	0.1	%/W	
Ripple rejection	$V_{IN} - V_{OUT} = 3\text{ V}$ , $V_{ripple} = 1\text{ V}_{pp}$ , $f = 120\text{ Hz}$	60	75		dB	
ADJ pin current			80	120	$\mu\text{A}$	
Change in ADJ pin current	$V_{IN} - V_{OUT} = 1.4\text{ V}$ to $10\text{ V}$ , $I_{OUT} = 10\text{ mA}$ to $800\text{ mA}$		0.2	10	$\mu\text{A}$	
Temperature stability	$T_J = \text{full range}$		0.5		%	
Long-term stability	1000 hrs, No load, $T_A = 125^{\circ}\text{C}$		0.3		%	
Output noise voltage (% of $V_{OUT}$ )	$f = 10\text{ Hz}$ to $100\text{ kHz}$		0.003		%	

(1) All characteristics are measured with a 10- $\mu\text{F}$  capacitor across the input and a 10- $\mu\text{F}$  capacitor across the output. Pulse testing techniques are used to maintain the junction temperature as close to the ambient temperature as possible.

(2) Dropout is defined as the  $V_{IN}$  to  $V_{OUT}$  differential at which  $V_{OUT}$  drops 100 mV below the value of  $V_{OUT}$ , measured at  $V_{IN} = V_{OUT(nom)} + 1.5\text{ V}$ .

(3) Current limit test specified under recommended operating conditions

**TYPICAL CHARACTERISTICS**

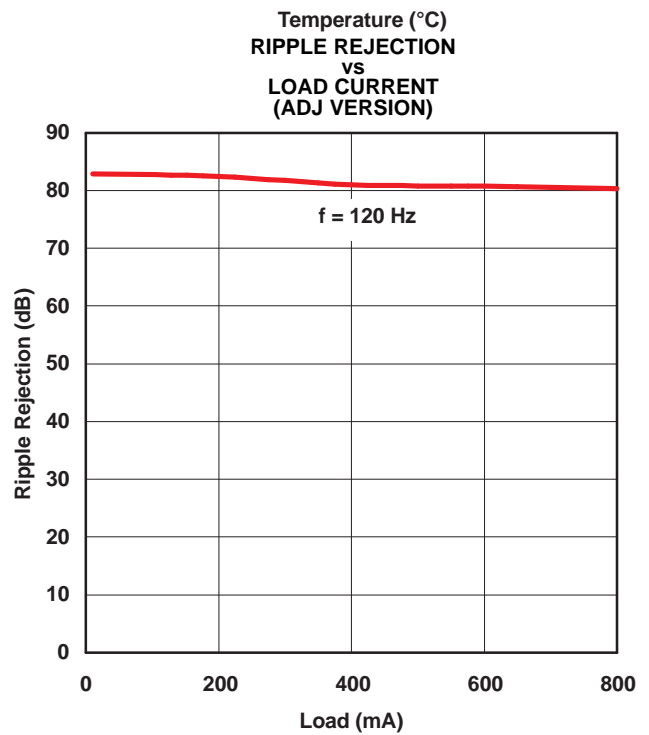
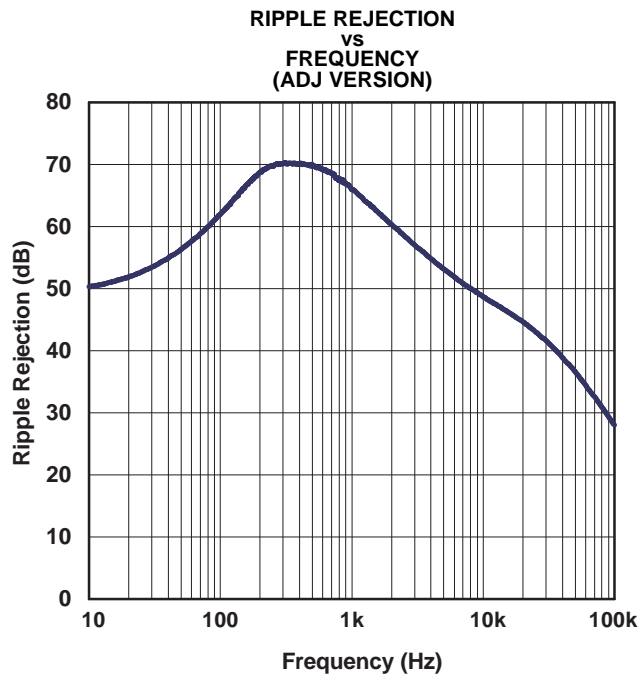
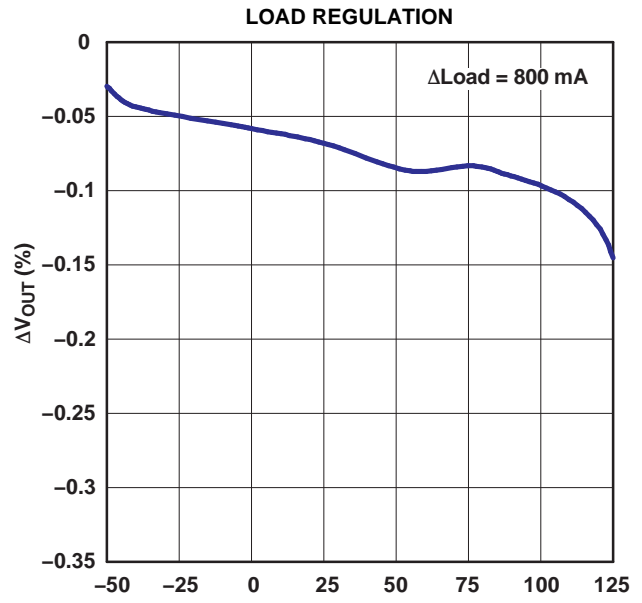
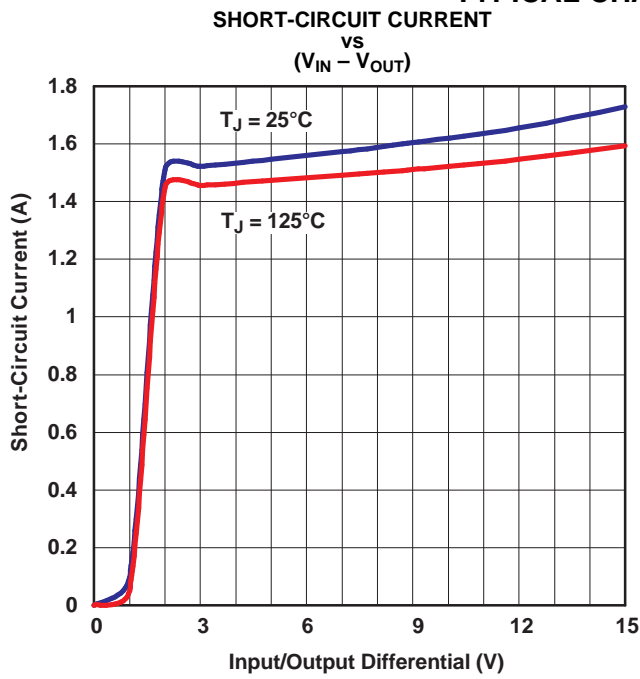

TYPICAL CHARACTERISTICS (continued)

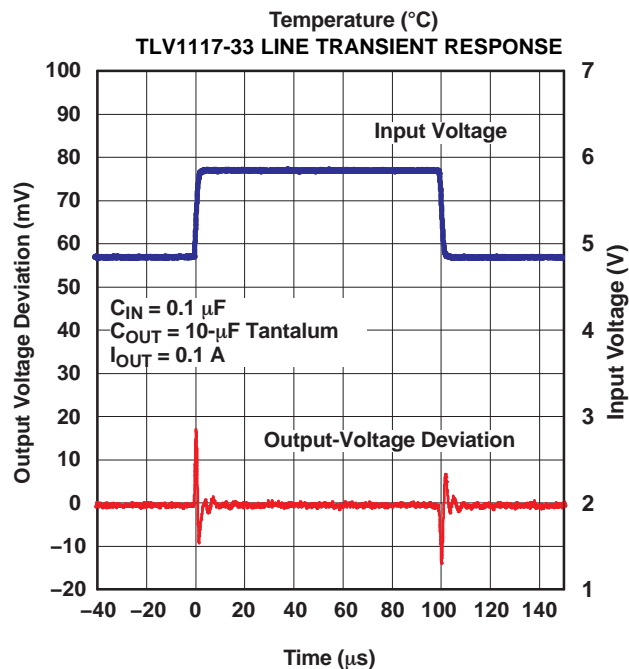
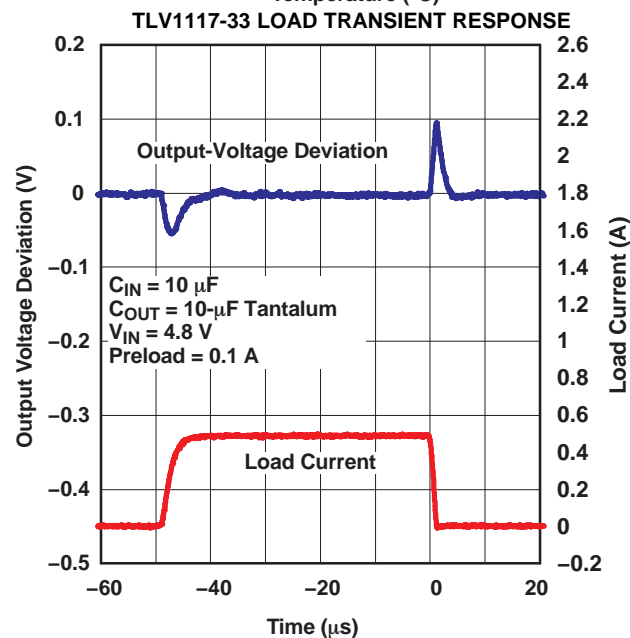
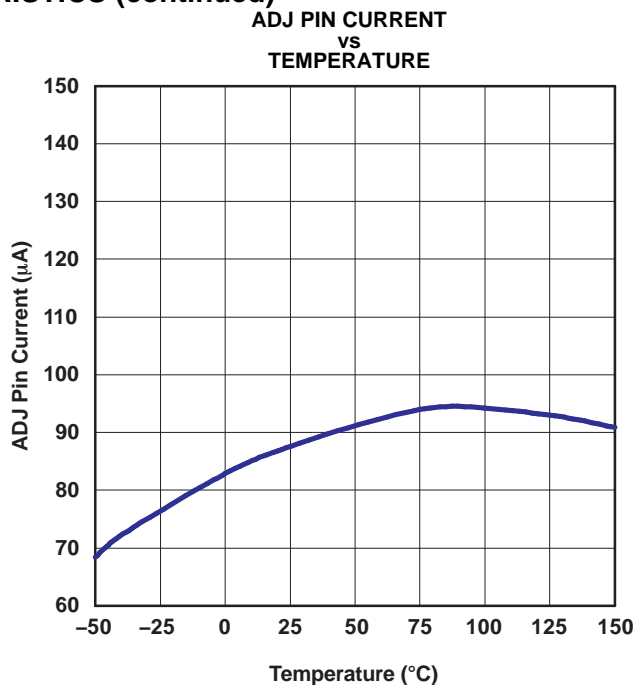
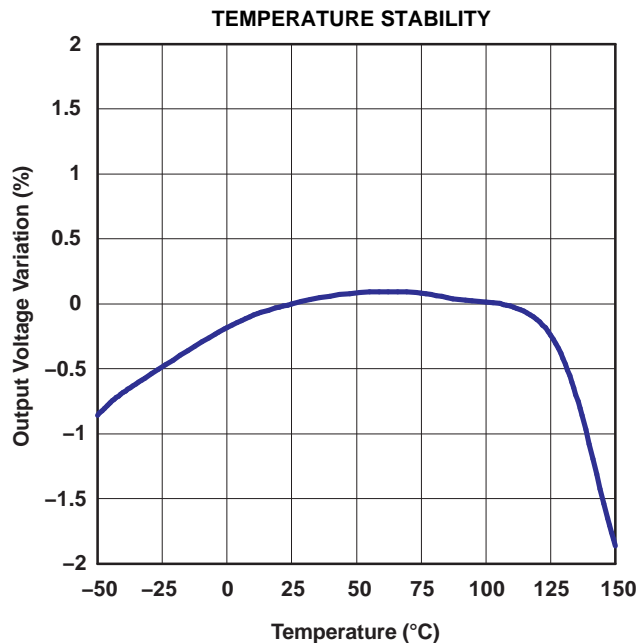

**TYPICAL CHARACTERISTICS (continued)**  
**DROPOUT VOLTAGE**  
**vs**  
**LOAD CURRENT**

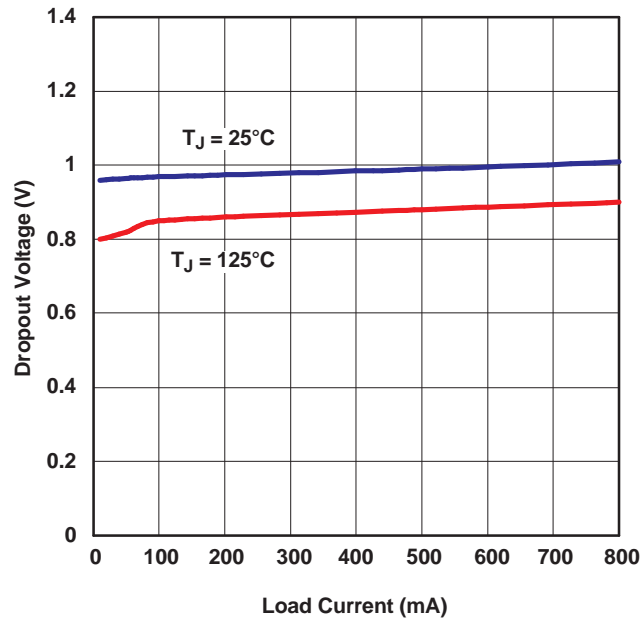

APPLICATION INFORMATION

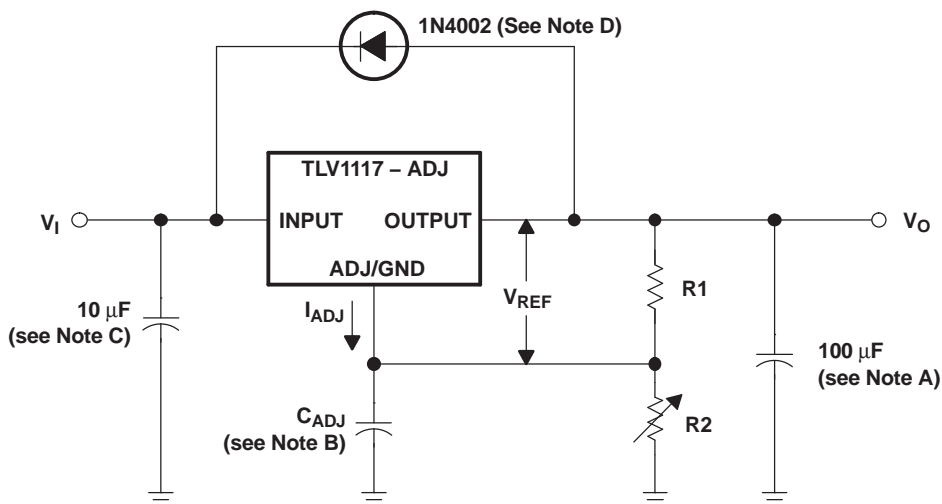

$V_{OUT}$  is calculated as:

$$V_{OUT} = V_{REF} \left( 1 + \frac{R2}{R1} \right) + (I_{ADJ} \times R2)$$

Because  $I_{ADJ}$  typically is 55  $\mu$ A, it is negligible in most applications.

- A. Output capacitor selection is critical for regulator stability. Larger  $C_{OUT}$  values benefit the regulator by improving transient response and loop stability.
- B.  $C_{ADJ}$  can be used to improve ripple rejection. If  $C_{ADJ}$  is used, a  $C_{OUT}$  that is larger in value than  $C_{ADJ}$  must be used.
- C.  $C_{IN}$  is recommended if TLV1117 is not located near the power-supply filter.
- D. An external diode is recommended to protect the regulator if the input instantaneously is shorted to GND.
- E. This device is designed to be stable with tantalum and aluminum electrolytic output capacitors having an ESR between 0.2  $\Omega$  and 10  $\Omega$ .

Figure 1. Basic Adjustable Regulator

## REVISION HISTORY

Changes from Revision J (April 2013) to Revision K	Page
• Added additional package options. ....	1

**PACKAGING INFORMATION**

Orderable Device	Status (1)	Package Type	Package Drawing	Pins	Package Qty	Eco Plan (2)	Lead/Ball Finish	MSL Peak Temp (3)	Op Temp (°C)	Top-Side Markings (4)	Samples
TLV1117-15CDCY	ACTIVE	SOT-223	DCY	4	80	Green (RoHS & no Sb/Br)	CU SN	Level-2-260C-1 YEAR	0 to 125	T2	<a href="#">Samples</a>
TLV1117-15CDCYG3	ACTIVE	SOT-223	DCY	4	80	Green (RoHS & no Sb/Br)	CU SN	Level-2-260C-1 YEAR	0 to 125	T2	<a href="#">Samples</a>
TLV1117-15CDCYR	ACTIVE	SOT-223	DCY	4	2500	Green (RoHS & no Sb/Br)	CU SN	Level-2-260C-1 YEAR	0 to 125	T2	<a href="#">Samples</a>
TLV1117-15CDCYRG3	ACTIVE	SOT-223	DCY	4	2500	Green (RoHS & no Sb/Br)	CU SN	Level-2-260C-1 YEAR	0 to 125	T2	<a href="#">Samples</a>
TLV1117-15CDRJR	ACTIVE	SON	DRJ	8	1000	Green (RoHS & no Sb/Br)	CU NIPDAU	Level-2-260C-1 YEAR	0 to 125	ZYH	<a href="#">Samples</a>
TLV1117-15CDRJRG4	ACTIVE	SON	DRJ	8	1000	Green (RoHS & no Sb/Br)	CU NIPDAU	Level-2-260C-1 YEAR	0 to 125	ZYH	<a href="#">Samples</a>
TLV1117-15CKVURG3	ACTIVE	PFM	KVU	3	2500	Green (RoHS & no Sb/Br)	CU SN	Level-3-260C-168 HR	0 to 125	ZE15	<a href="#">Samples</a>
TLV1117-15IDCY	ACTIVE	SOT-223	DCY	4	80	Green (RoHS & no Sb/Br)	CU SN	Level-2-260C-1 YEAR	-40 to 125	T3	<a href="#">Samples</a>
TLV1117-15IDCYG3	ACTIVE	SOT-223	DCY	4	80	Green (RoHS & no Sb/Br)	CU SN	Level-2-260C-1 YEAR	-40 to 125	T3	<a href="#">Samples</a>
TLV1117-15IDCYR	ACTIVE	SOT-223	DCY	4	2500	Green (RoHS & no Sb/Br)	CU SN	Level-2-260C-1 YEAR	-40 to 125	T3	<a href="#">Samples</a>
TLV1117-15IDCYRG3	ACTIVE	SOT-223	DCY	4	2500	Green (RoHS & no Sb/Br)	CU SN	Level-2-260C-1 YEAR	-40 to 125	T3	<a href="#">Samples</a>
TLV1117-15IDRJR	ACTIVE	SON	DRJ	8	1000	Green (RoHS & no Sb/Br)	CU NIPDAU	Level-2-260C-1 YEAR	-40 to 125	ZYJ	<a href="#">Samples</a>
TLV1117-15IDRJRG4	ACTIVE	SON	DRJ	8	1000	Green (RoHS & no Sb/Br)	CU NIPDAU	Level-2-260C-1 YEAR	-40 to 125	ZYJ	<a href="#">Samples</a>
TLV1117-15IKVURG3	ACTIVE	PFM	KVU	3	2500	Green (RoHS & no Sb/Br)	CU SN	Level-3-260C-168 HR	-40 to 125	ZF15	<a href="#">Samples</a>
TLV1117-18CDCY	ACTIVE	SOT-223	DCY	4	80	Green (RoHS & no Sb/Br)	CU SN	Level-2-260C-1 YEAR	0 to 125	T4	<a href="#">Samples</a>
TLV1117-18CDCYG3	ACTIVE	SOT-223	DCY	4	80	Green (RoHS & no Sb/Br)	CU SN	Level-2-260C-1 YEAR	0 to 125	T4	<a href="#">Samples</a>
TLV1117-18CDCYR	ACTIVE	SOT-223	DCY	4	2500	Green (RoHS & no Sb/Br)	CU SN	Level-2-260C-1 YEAR	0 to 125	T4	<a href="#">Samples</a>

Orderable Device	Status (1)	Package Type	Package Drawing	Pins	Package Qty	Eco Plan (2)	Lead/Ball Finish	MSL Peak Temp (3)	Op Temp (°C)	Top-Side Markings (4)	Samples
TLV1117-18CDCYRG3	ACTIVE	SOT-223	DCY	4	2500	Green (RoHS & no Sb/Br)	CU SN	Level-2-260C-1 YEAR	0 to 125	T4	<a href="#">Samples</a>
TLV1117-18CDRJ	ACTIVE	SON	DRJ	8	1000	Green (RoHS & no Sb/Br)	CU NIPDAU	Level-2-260C-1 YEAR	0 to 125	ZYK	<a href="#">Samples</a>
TLV1117-18CDRJRG4	ACTIVE	SON	DRJ	8	1000	Green (RoHS & no Sb/Br)	CU NIPDAU	Level-2-260C-1 YEAR	0 to 125	ZYK	<a href="#">Samples</a>
TLV1117-18CKVURG3	ACTIVE	PFM	KVU	3	2500	Green (RoHS & no Sb/Br)	CU SN	Level-3-260C-168 HR	0 to 125	ZE18	<a href="#">Samples</a>
TLV1117-18IDCY	ACTIVE	SOT-223	DCY	4	80	Green (RoHS & no Sb/Br)	CU SN	Level-2-260C-1 YEAR	-40 to 125	T5	<a href="#">Samples</a>
TLV1117-18IDCYG3	ACTIVE	SOT-223	DCY	4	80	Green (RoHS & no Sb/Br)	CU SN	Level-2-260C-1 YEAR	-40 to 125	T5	<a href="#">Samples</a>
TLV1117-18IDCYR	ACTIVE	SOT-223	DCY	4	2500	Green (RoHS & no Sb/Br)	CU SN	Level-2-260C-1 YEAR	-40 to 125	T5	<a href="#">Samples</a>
TLV1117-18IDCYRG3	ACTIVE	SOT-223	DCY	4	2500	Green (RoHS & no Sb/Br)	CU SN	Level-2-260C-1 YEAR	-40 to 125	T5	<a href="#">Samples</a>
TLV1117-18IDRJ	ACTIVE	SON	DRJ	8	1000	Green (RoHS & no Sb/Br)	CU NIPDAU	Level-2-260C-1 YEAR	-40 to 125	ZYL	<a href="#">Samples</a>
TLV1117-18IDRJRG4	ACTIVE	SON	DRJ	8	1000	Green (RoHS & no Sb/Br)	CU NIPDAU	Level-2-260C-1 YEAR	-40 to 125	ZYL	<a href="#">Samples</a>
TLV1117-18IKVURG3	ACTIVE	PFM	KVU	3	2500	Green (RoHS & no Sb/Br)	CU SN	Level-3-260C-168 HR	-40 to 125	ZF18	<a href="#">Samples</a>
TLV1117-25CDCY	ACTIVE	SOT-223	DCY	4	80	Green (RoHS & no Sb/Br)	CU SN	Level-2-260C-1 YEAR	0 to 125	T6	<a href="#">Samples</a>
TLV1117-25CDCYG3	ACTIVE	SOT-223	DCY	4	80	Green (RoHS & no Sb/Br)	CU SN	Level-2-260C-1 YEAR	0 to 125	T6	<a href="#">Samples</a>
TLV1117-25CDCYR	ACTIVE	SOT-223	DCY	4	2500	Green (RoHS & no Sb/Br)	CU SN	Level-2-260C-1 YEAR	0 to 125	T6	<a href="#">Samples</a>
TLV1117-25CDCYRG3	ACTIVE	SOT-223	DCY	4	2500	Green (RoHS & no Sb/Br)	CU SN	Level-2-260C-1 YEAR	0 to 125	T6	<a href="#">Samples</a>
TLV1117-25CDRJ	ACTIVE	SON	DRJ	8	1000	Green (RoHS & no Sb/Br)	CU NIPDAU	Level-2-260C-1 YEAR	0 to 125	ZYM	<a href="#">Samples</a>
TLV1117-25CDRJRG4	ACTIVE	SON	DRJ	8	1000	Green (RoHS & no Sb/Br)	CU NIPDAU	Level-2-260C-1 YEAR	0 to 125	ZYM	<a href="#">Samples</a>
TLV1117-25CKVURG3	ACTIVE	PFM	KVU	3	2500	Green (RoHS & no Sb/Br)	CU SN	Level-3-260C-168 HR	0 to 125	ZE25	<a href="#">Samples</a>

Orderable Device	Status (1)	Package Type	Package Drawing	Pins	Package Qty	Eco Plan (2)	Lead/Ball Finish	MSL Peak Temp (3)	Op Temp (°C)	Top-Side Markings (4)	Samples
TLV1117-25IDCY	ACTIVE	SOT-223	DCY	4	80	Green (RoHS & no Sb/Br)	CU SN	Level-2-260C-1 YEAR	-40 to 125	T8	<a href="#">Samples</a>
TLV1117-25IDCYG3	ACTIVE	SOT-223	DCY	4	80	Green (RoHS & no Sb/Br)	CU SN	Level-2-260C-1 YEAR	-40 to 125	T8	<a href="#">Samples</a>
TLV1117-25IDCYR	ACTIVE	SOT-223	DCY	4	2500	Green (RoHS & no Sb/Br)	CU SN	Level-2-260C-1 YEAR	-40 to 125	T8	<a href="#">Samples</a>
TLV1117-25IDCYRG3	ACTIVE	SOT-223	DCY	4	2500	Green (RoHS & no Sb/Br)	CU SN	Level-2-260C-1 YEAR	-40 to 125	T8	<a href="#">Samples</a>
TLV1117-25IDRJR	ACTIVE	SON	DRJ	8	1000	Green (RoHS & no Sb/Br)	CU NIPDAU	Level-2-260C-1 YEAR	-40 to 125	ZYN	<a href="#">Samples</a>
TLV1117-25IDRJRG4	ACTIVE	SON	DRJ	8	1000	Green (RoHS & no Sb/Br)	CU NIPDAU	Level-2-260C-1 YEAR	-40 to 125	ZYN	<a href="#">Samples</a>
TLV1117-25IKCS	PREVIEW	TO-220	KCS	3	50	TBD	Call TI	Call TI	-40 to 125		
TLV1117-25IKVURG3	ACTIVE	PFM	KVU	3	2500	Green (RoHS & no Sb/Br)	CU SN	Level-3-260C-168 HR	-40 to 125	ZF25	<a href="#">Samples</a>
TLV1117-33CDCY	ACTIVE	SOT-223	DCY	4	80	Green (RoHS & no Sb/Br)	CU SN	Level-2-260C-1 YEAR	0 to 125	V3	<a href="#">Samples</a>
TLV1117-33CDCYG3	ACTIVE	SOT-223	DCY	4	80	Green (RoHS & no Sb/Br)	CU SN	Level-2-260C-1 YEAR	0 to 125	V3	<a href="#">Samples</a>
TLV1117-33CDCYR	ACTIVE	SOT-223	DCY	4	2500	Green (RoHS & no Sb/Br)	CU SN	Level-2-260C-1 YEAR	0 to 125	V3	<a href="#">Samples</a>
TLV1117-33CDCYRG3	ACTIVE	SOT-223	DCY	4	2500	Green (RoHS & no Sb/Br)	CU SN	Level-2-260C-1 YEAR	0 to 125	V3	<a href="#">Samples</a>
TLV1117-33CDRJR	ACTIVE	SON	DRJ	8	1000	Green (RoHS & no Sb/Br)	CU NIPDAU	Level-2-260C-1 YEAR	0 to 125	ZYP	<a href="#">Samples</a>
TLV1117-33CDRJRG4	ACTIVE	SON	DRJ	8	1000	Green (RoHS & no Sb/Br)	CU NIPDAU	Level-2-260C-1 YEAR	0 to 125	ZYP	<a href="#">Samples</a>
TLV1117-33CKVURG3	ACTIVE	PFM	KVU	3	2500	Green (RoHS & no Sb/Br)	CU SN	Level-3-260C-168 HR	0 to 125	ZE33	<a href="#">Samples</a>
TLV1117-33IDCY	ACTIVE	SOT-223	DCY	4	80	Green (RoHS & no Sb/Br)	CU SN	Level-2-260C-1 YEAR	-40 to 125	(V3 ~ VS)	<a href="#">Samples</a>
TLV1117-33IDCYG3	ACTIVE	SOT-223	DCY	4	80	Green (RoHS & no Sb/Br)	CU SN	Level-2-260C-1 YEAR	-40 to 125	(V3 ~ VS)	<a href="#">Samples</a>
TLV1117-33IDCYR	ACTIVE	SOT-223	DCY	4	2500	Green (RoHS & no Sb/Br)	CU SN	Level-2-260C-1 YEAR	-40 to 125	VS	<a href="#">Samples</a>

Orderable Device	Status (1)	Package Type	Package Drawing	Pins	Package Qty	Eco Plan (2)	Lead/Ball Finish	MSL Peak Temp (3)	Op Temp (°C)	Top-Side Markings (4)	Samples
TLV1117-33IDCYRG3	ACTIVE	SOT-223	DCY	4	2500	Green (RoHS & no Sb/Br)	CU SN	Level-2-260C-1 YEAR	-40 to 125	VS	<a href="#">Samples</a>
TLV1117-33IDRJR	ACTIVE	SON	DRJ	8	1000	Green (RoHS & no Sb/Br)	CU NIPDAU	Level-2-260C-1 YEAR	-40 to 125	ZYR	<a href="#">Samples</a>
TLV1117-33IDRJR4	ACTIVE	SON	DRJ	8	1000	Green (RoHS & no Sb/Br)	CU NIPDAU	Level-2-260C-1 YEAR	-40 to 125	ZYR	<a href="#">Samples</a>
TLV1117-33IKVURG3	ACTIVE	PFM	KVU	3	2500	Green (RoHS & no Sb/Br)	CU SN	Level-3-260C-168 HR	-40 to 125	ZF33	<a href="#">Samples</a>
TLV1117-50CDCY	ACTIVE	SOT-223	DCY	4	80	Green (RoHS & no Sb/Br)	CU SN	Level-2-260C-1 YEAR	0 to 125	VT	<a href="#">Samples</a>
TLV1117-50CDCYG3	ACTIVE	SOT-223	DCY	4	80	Green (RoHS & no Sb/Br)	CU SN	Level-2-260C-1 YEAR	0 to 125	VT	<a href="#">Samples</a>
TLV1117-50CDCYR	ACTIVE	SOT-223	DCY	4	2500	Green (RoHS & no Sb/Br)	CU SN	Level-2-260C-1 YEAR	0 to 125	VT	<a href="#">Samples</a>
TLV1117-50CDCYRG3	ACTIVE	SOT-223	DCY	4	2500	Green (RoHS & no Sb/Br)	CU SN	Level-2-260C-1 YEAR	0 to 125	VT	<a href="#">Samples</a>
TLV1117-50CDRJR	ACTIVE	SON	DRJ	8	1000	Green (RoHS & no Sb/Br)	CU NIPDAU	Level-2-260C-1 YEAR	0 to 125	ZE50	<a href="#">Samples</a>
TLV1117-50CDRJR4	ACTIVE	SON	DRJ	8	1000	Green (RoHS & no Sb/Br)	CU NIPDAU	Level-2-260C-1 YEAR	0 to 125	ZE50	<a href="#">Samples</a>
TLV1117-50CKVURG3	ACTIVE	PFM	KVU	3	2500	Green (RoHS & no Sb/Br)	CU SN	Level-3-260C-168 HR	0 to 125	ZE50	<a href="#">Samples</a>
TLV1117-50IDCY	ACTIVE	SOT-223	DCY	4	80	Green (RoHS & no Sb/Br)	CU SN	Level-2-260C-1 YEAR	-40 to 125	VU	<a href="#">Samples</a>
TLV1117-50IDCYG3	ACTIVE	SOT-223	DCY	4	80	Green (RoHS & no Sb/Br)	CU SN	Level-2-260C-1 YEAR	-40 to 125	VU	<a href="#">Samples</a>
TLV1117-50IDCYR	ACTIVE	SOT-223	DCY	4	2500	Green (RoHS & no Sb/Br)	CU SN	Level-2-260C-1 YEAR	-40 to 125	VU	<a href="#">Samples</a>
TLV1117-50IDCYRG3	ACTIVE	SOT-223	DCY	4	2500	Green (RoHS & no Sb/Br)	CU SN	Level-2-260C-1 YEAR	-40 to 125	VU	<a href="#">Samples</a>
TLV1117-50IDRJR	ACTIVE	SON	DRJ	8	1000	Green (RoHS & no Sb/Br)	CU NIPDAU	Level-2-260C-1 YEAR	-40 to 125	ZF50	<a href="#">Samples</a>
TLV1117-50IDRJR4	ACTIVE	SON	DRJ	8	1000	Green (RoHS & no Sb/Br)	CU NIPDAU	Level-2-260C-1 YEAR	-40 to 125	ZF50	<a href="#">Samples</a>
TLV1117-50IKVURG3	ACTIVE	PFM	KVU	3	2500	Green (RoHS & no Sb/Br)	CU SN	Level-3-260C-168 HR	-40 to 125	ZF50	<a href="#">Samples</a>

Orderable Device	Status (1)	Package Type	Package Drawing	Pins	Package Qty	Eco Plan (2)	Lead/Ball Finish	MSL Peak Temp (3)	Op Temp (°C)	Top-Side Markings (4)	Samples
TLV1117CDCY	ACTIVE	SOT-223	DCY	4	80	Green (RoHS & no Sb/Br)	CU SN	Level-2-260C-1 YEAR	0 to 125	V4	<a href="#">Samples</a>
TLV1117CDCYG3	ACTIVE	SOT-223	DCY	4	80	Green (RoHS & no Sb/Br)	CU SN	Level-2-260C-1 YEAR	0 to 125	V4	<a href="#">Samples</a>
TLV1117CDCYR	ACTIVE	SOT-223	DCY	4	2500	Green (RoHS & no Sb/Br)	CU SN	Level-2-260C-1 YEAR	0 to 125	V4	<a href="#">Samples</a>
TLV1117CDCYRG3	ACTIVE	SOT-223	DCY	4	2500	Green (RoHS & no Sb/Br)	CU SN	Level-2-260C-1 YEAR	0 to 125	V4	<a href="#">Samples</a>
TLV1117CDRJR	ACTIVE	SON	DRJ	8	1000	Green (RoHS & no Sb/Br)	CU NIPDAU	Level-2-260C-1 YEAR	0 to 125	ZYS	<a href="#">Samples</a>
TLV1117CDRJR4	ACTIVE	SON	DRJ	8	1000	Green (RoHS & no Sb/Br)	CU NIPDAU	Level-2-260C-1 YEAR	0 to 125	ZYS	<a href="#">Samples</a>
TLV1117CKCS	ACTIVE	TO-220	KCS	3	50	Pb-Free (RoHS)	CU SN	N / A for Pkg Type	0 to 125	TLV1117C	<a href="#">Samples</a>
TLV1117CKCSE3	ACTIVE	TO-220	KCS	3	50	Pb-Free (RoHS)	CU SN	N / A for Pkg Type	0 to 125	TLV1117C	<a href="#">Samples</a>
TLV1117CKCT	PREVIEW	TO-220	KCT	3	50	Pb-Free (RoHS)	CU SN	N / A for Pkg Type	0 to 125		
TLV1117CKTER	OBSOLETE	PFM	KTE	3		TBD	Call TI	Call TI	0 to 125	TLV1117C	
TLV1117CKTPR	OBSOLETE	PFM	KTP	2		TBD	Call TI	Call TI	0 to 125	TV1117	
TLV1117CKTPRG3	OBSOLETE	PFM	KTP	2		TBD	Call TI	Call TI	0 to 125	TV1117	
TLV1117CKTTR	ACTIVE	DDPAK/TO-263	KTT	3	500	Green (RoHS & no Sb/Br)	CU SN	Level-3-245C-168 HR	0 to 125	TLV1117C	<a href="#">Samples</a>
TLV1117CKTTRG3	ACTIVE	DDPAK/TO-263	KTT	3	500	Green (RoHS & no Sb/Br)	CU SN	Level-3-245C-168 HR	0 to 125	TLV1117C	<a href="#">Samples</a>
TLV1117CKVURG3	ACTIVE	PFM	KVU	3	2500	Green (RoHS & no Sb/Br)	CU SN	Level-3-260C-168 HR	0 to 125	TV1117	<a href="#">Samples</a>
TLV1117IDCY	ACTIVE	SOT-223	DCY	4	80	Green (RoHS & no Sb/Br)	CU SN	Level-2-260C-1 YEAR	-40 to 125	V2	<a href="#">Samples</a>
TLV1117IDCYG3	ACTIVE	SOT-223	DCY	4	80	Green (RoHS & no Sb/Br)	CU SN	Level-2-260C-1 YEAR	-40 to 125	V2	<a href="#">Samples</a>
TLV1117IDCYR	ACTIVE	SOT-223	DCY	4	2500	Green (RoHS & no Sb/Br)	CU SN	Level-2-260C-1 YEAR	-40 to 125	V2	<a href="#">Samples</a>
TLV1117IDCYRG3	ACTIVE	SOT-223	DCY	4	2500	Green (RoHS & no Sb/Br)	CU SN	Level-2-260C-1 YEAR	-40 to 125	V2	<a href="#">Samples</a>

Orderable Device	Status (1)	Package Type	Package Drawing	Pins	Package Qty	Eco Plan (2)	Lead/Ball Finish	MSL Peak Temp (3)	Op Temp (°C)	Top-Side Markings (4)	Samples
TLV1117IDRJR	ACTIVE	SON	DRJ	8	1000	Green (RoHS & no Sb/Br)	CU NIPDAU	Level-2-260C-1 YEAR	-40 to 125	ZYT	<a href="#">Samples</a>
TLV1117IDRJR4	ACTIVE	SON	DRJ	8	1000	Green (RoHS & no Sb/Br)	CU NIPDAU	Level-2-260C-1 YEAR	-40 to 125	ZYT	<a href="#">Samples</a>
TLV1117IKCS	ACTIVE	TO-220	KCS	3	50	Pb-Free (RoHS)	CU SN	N / A for Pkg Type	-40 to 125	TLV1117I	<a href="#">Samples</a>
TLV1117IKCSE3	ACTIVE	TO-220	KCS	3	50	Pb-Free (RoHS)	CU SN	N / A for Pkg Type	-40 to 125	TLV1117I	<a href="#">Samples</a>
TLV1117IKTER	OBSOLETE	PFM	KTE	3		TBD	Call TI	Call TI	-40 to 125	TLV1117I	
TLV1117IKTPR	OBSOLETE	PFM	KTP	2		TBD	Call TI	Call TI	-40 to 125	TY1117	
TLV1117IKTPRG3	OBSOLETE	PFM	KTP	2		TBD	Call TI	Call TI	-40 to 125	TY1117	
TLV1117IKTTR	ACTIVE	DDPAK/ TO-263	KTT	3	500	Green (RoHS & no Sb/Br)	CU SN	Level-3-245C-168 HR	-40 to 125	TLV1117I	<a href="#">Samples</a>
TLV1117IKTTRG3	ACTIVE	DDPAK/ TO-263	KTT	3	500	Green (RoHS & no Sb/Br)	CU SN	Level-3-245C-168 HR	-40 to 125	TLV1117I	<a href="#">Samples</a>
TLV1117IKVURG3	ACTIVE	PFM	KVU	3	2500	Green (RoHS & no Sb/Br)	CU SN	Level-3-260C-168 HR	-40 to 125	TY1117	<a href="#">Samples</a>

(1) The marketing status values are defined as follows:

**ACTIVE:** Product device recommended for new designs.

**LIFEBUY:** TI has announced that the device will be discontinued, and a lifetime-buy period is in effect.

**NRND:** Not recommended for new designs. Device is in production to support existing customers, but TI does not recommend using this part in a new design.

**PREVIEW:** Device has been announced but is not in production. Samples may or may not be available.

**OBSOLETE:** TI has discontinued the production of the device.

(2) Eco Plan - The planned eco-friendly classification: Pb-Free (RoHS), Pb-Free (RoHS Exempt), or Green (RoHS & no Sb/Br) - please check <http://www.ti.com/productcontent> for the latest availability information and additional product content details.

**TBD:** The Pb-Free/Green conversion plan has not been defined.

**Pb-Free (RoHS):** TI's terms "Lead-Free" or "Pb-Free" mean semiconductor products that are compatible with the current RoHS requirements for all 6 substances, including the requirement that lead not exceed 0.1% by weight in homogeneous materials. Where designed to be soldered at high temperatures, TI Pb-Free products are suitable for use in specified lead-free processes.

**Pb-Free (RoHS Exempt):** This component has a RoHS exemption for either 1) lead-based flip-chip solder bumps used between the die and package, or 2) lead-based die adhesive used between the die and leadframe. The component is otherwise considered Pb-Free (RoHS compatible) as defined above.

**Green (RoHS & no Sb/Br):** TI defines "Green" to mean Pb-Free (RoHS compatible), and free of Bromine (Br) and Antimony (Sb) based flame retardants (Br or Sb do not exceed 0.1% by weight in homogeneous material)

(3) MSL, Peak Temp. -- The Moisture Sensitivity Level rating according to the JEDEC industry standard classifications, and peak solder temperature.

<sup>(4)</sup> Multiple Top-Side Markings will be inside parentheses. Only one Top-Side Marking contained in parentheses and separated by a "~" will appear on a device. If a line is indented then it is a continuation of the previous line and the two combined represent the entire Top-Side Marking for that device.

**Important Information and Disclaimer:**The information provided on this page represents TI's knowledge and belief as of the date that it is provided. TI bases its knowledge and belief on information provided by third parties, and makes no representation or warranty as to the accuracy of such information. Efforts are underway to better integrate information from third parties. TI has taken and continues to take reasonable steps to provide representative and accurate information but may not have conducted destructive testing or chemical analysis on incoming materials and chemicals. TI and TI suppliers consider certain information to be proprietary, and thus CAS numbers and other limited information may not be available for release.

In no event shall TI's liability arising out of such information exceed the total purchase price of the TI part(s) at issue in this document sold by TI to Customer on an annual basis.

DCY (R-PDSO-G4)

PLASTIC SMALL-OUTLINE

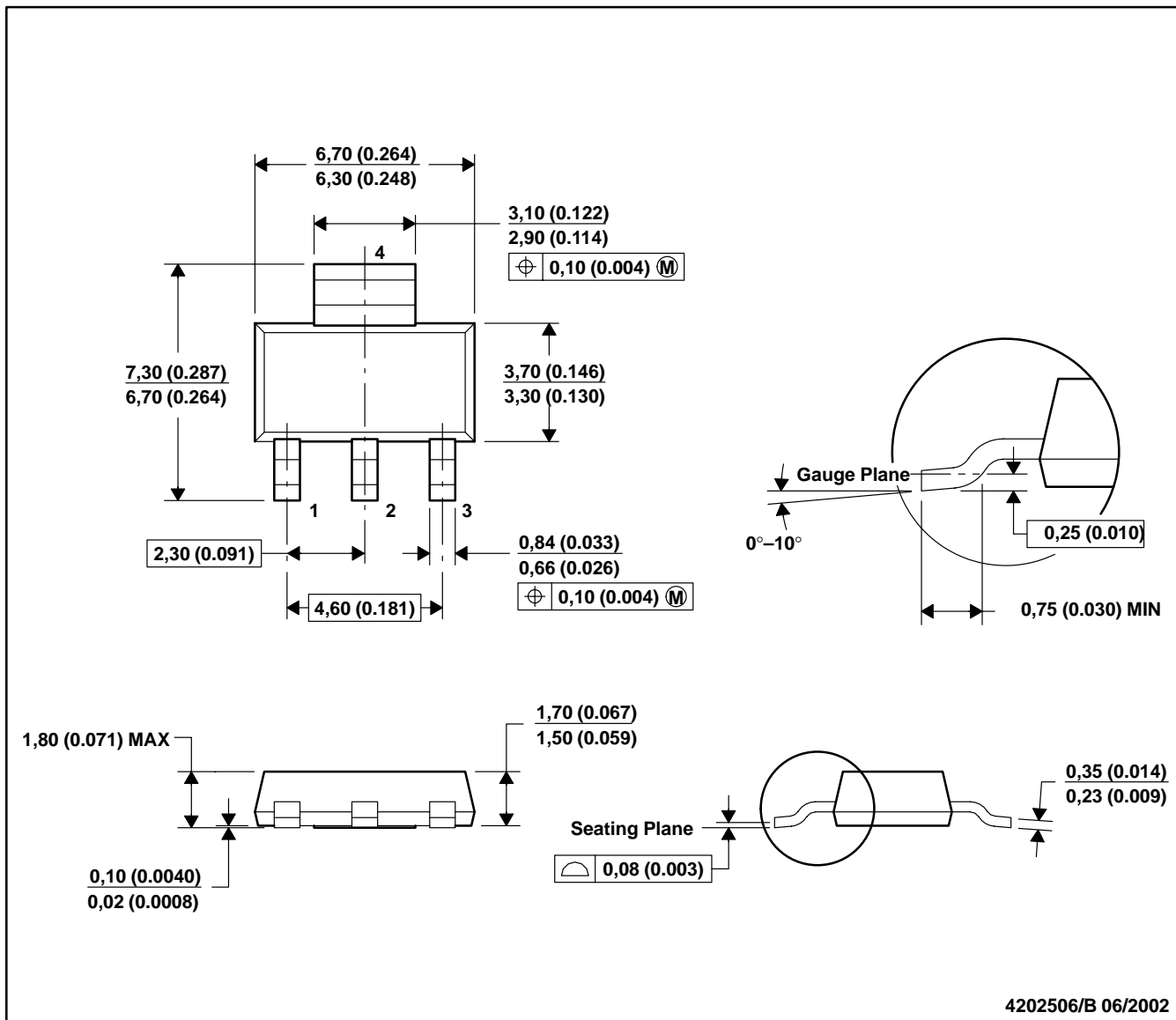

- NOTES: A. All linear dimensions are in millimeters (inches).  
 B. This drawing is subject to change without notice.  
 C. Body dimensions do not include mold flash or protrusion.  
 D. Falls within JEDEC TO-261 Variation AA.

DCY (R-PDSO-G4)

PLASTIC SMALL OUTLINE

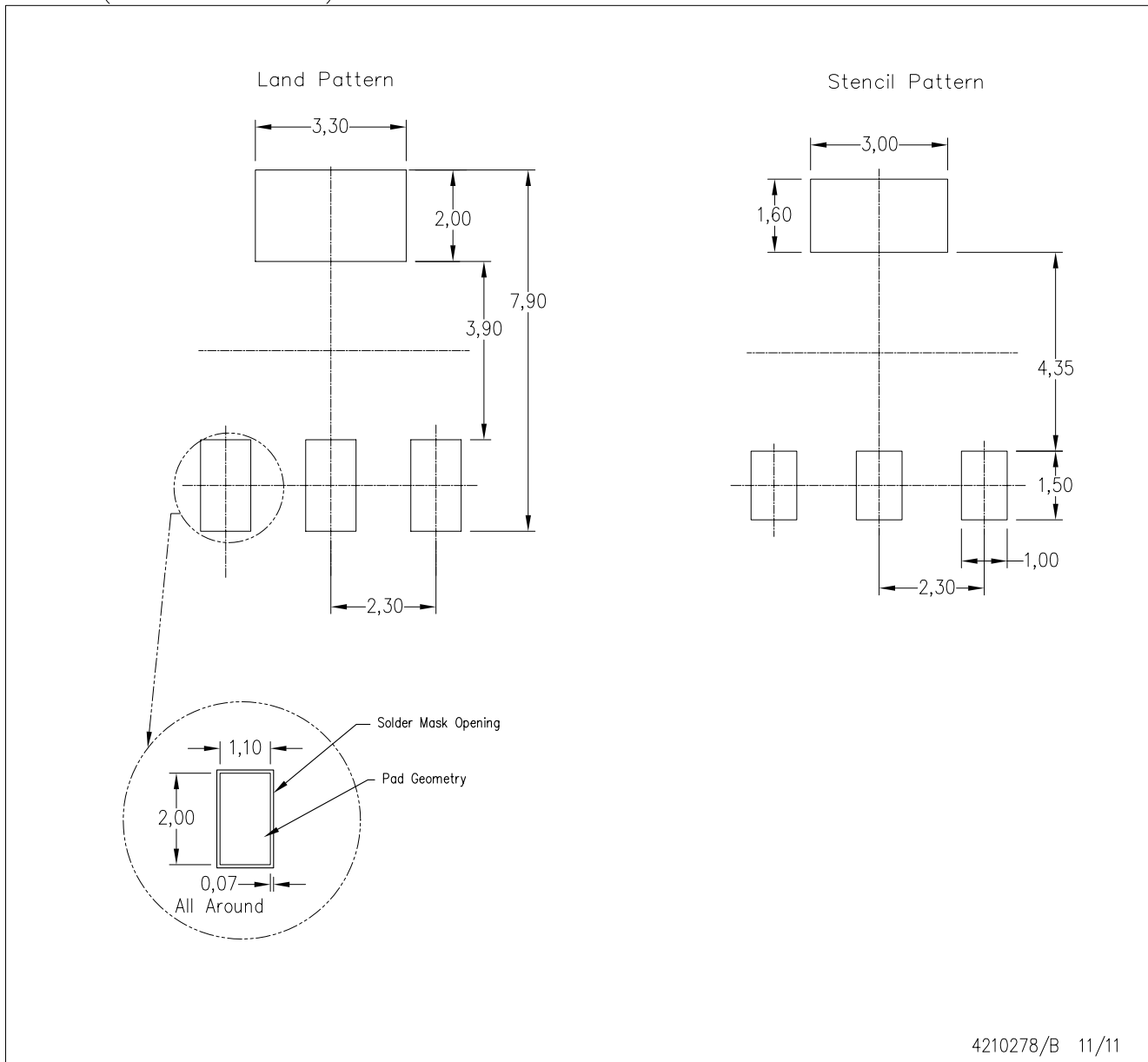

- NOTES:
- A. All linear dimensions are in millimeters.
  - B. This drawing is subject to change without notice.
  - C. Customers should place a note on the circuit board fabrication drawing not to alter the center solder mask defined pad.
  - D. Publication IPC-7351 is recommended for alternate designs.
  - E. Laser cutting apertures with trapezoidal walls and also rounding corners will offer better paste release. Customers should contact their board assembly site for stencil design recommendations.

DRJ (S-PWSON-N8)

PLASTIC SMALL OUTLINE NO-LEAD

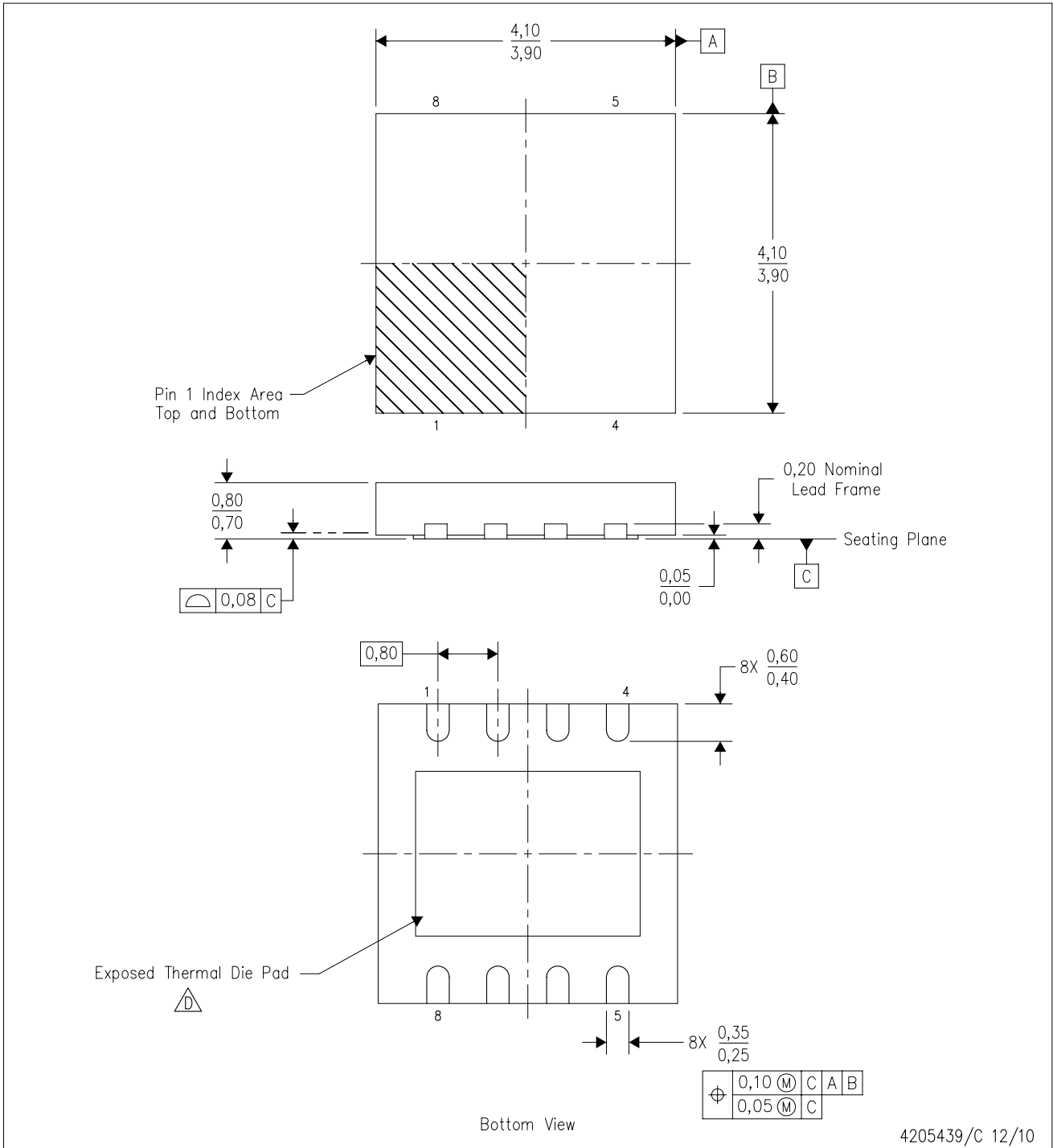

4205439/C 12/10

- NOTES:
- A. All linear dimensions are in millimeters. Dimensioning and tolerancing per ASME Y14.5M-1994.
  - B. This drawing is subject to change without notice.
  - C. SON (Small Outline No-Lead) package configuration.
  - The package thermal pad must be soldered to the board for thermal and mechanical performance. See the Product Data Sheet for details regarding the exposed thermal pad dimensions.
  - E. Package complies to JEDEC MO-229 variation WGGB.

## THERMAL PAD MECHANICAL DATA

DRJ (S-PWSON-N8)

PLASTIC SMALL OUTLINE NO-LEAD

### THERMAL INFORMATION

This package incorporates an exposed thermal pad that is designed to be attached directly to an external heatsink. The thermal pad must be soldered directly to the printed circuit board (PCB). After soldering, the PCB can be used as a heatsink. In addition, through the use of thermal vias, the thermal pad can be attached directly to the appropriate copper plane shown in the electrical schematic for the device, or alternatively, can be attached to a special heatsink structure designed into the PCB. This design optimizes the heat transfer from the integrated circuit (IC).

For information on the Quad Flatpack No-Lead (QFN) package and its advantages, refer to Application Report, QFN/SON PCB Attachment, Texas Instruments Literature No. SLUA271. This document is available at [www.ti.com](http://www.ti.com).

The exposed thermal pad dimensions for this package are shown in the following illustration.

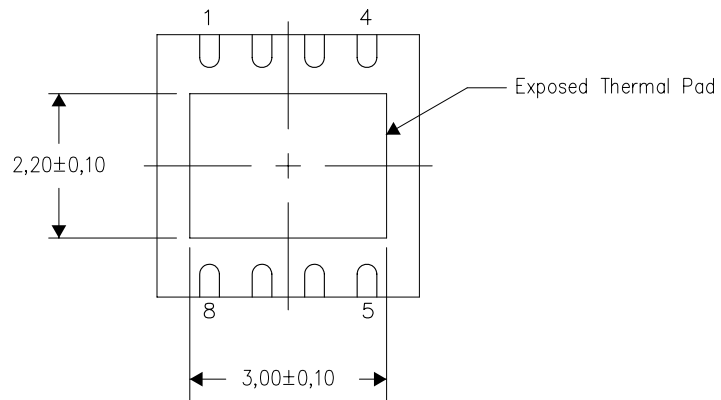

Bottom View

Exposed Thermal Pad Dimensions

4206882/F 01/11

NOTE: All linear dimensions are in millimeters

DRJ (S-PWSON-N8)

SMALL PACKAGE OUTLINE NO-LEAD

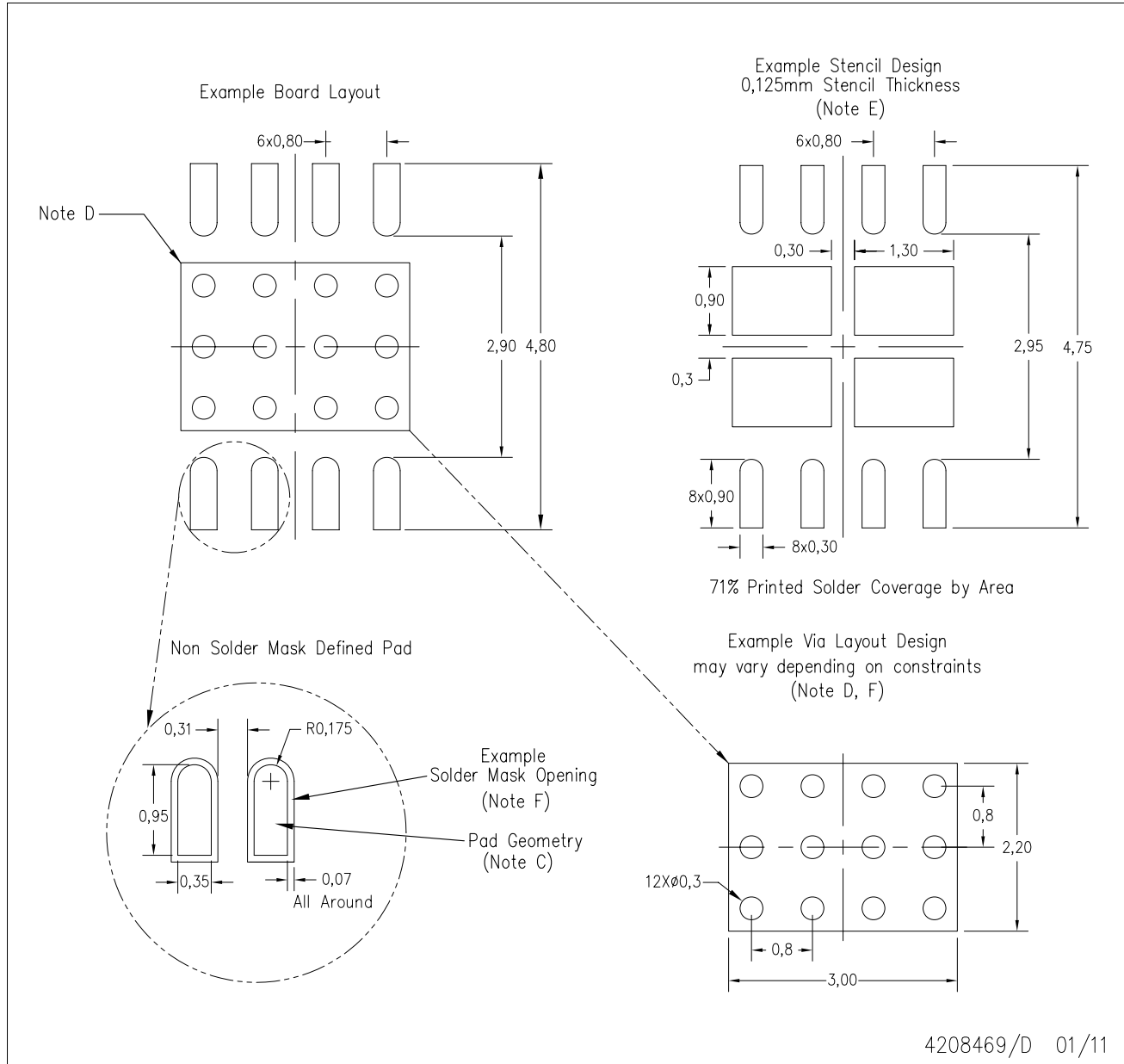

- NOTES:
- A. All linear dimensions are in millimeters.
  - B. This drawing is subject to change without notice.
  - C. Publication IPC-7351 is recommended for alternate designs.
  - D. This package is designed to be soldered to a thermal pad on the board. Refer to Application Note, Quad Flat-Pack Packages, Texas Instruments Literature No. SLUA271, and also the Product Data Sheets for specific thermal information, via requirements, and recommended board layout. These documents are available at [www.ti.com](http://www.ti.com) <<http://www.ti.com>>.
  - E. Laser cutting apertures with electropolish and also rounding corners will offer better paste release. Customers should contact their board assembly site for stencil design recommendations. Refer to IPC 7525 for stencil design considerations.
  - F. Customers should contact their board fabrication site for solder mask tolerances and vias tenting recommendations for vias placed in the thermal pad.

KTE (R-PSFM-G3)

PowerFLEX™ PLASTIC FLANGE-MOUNT

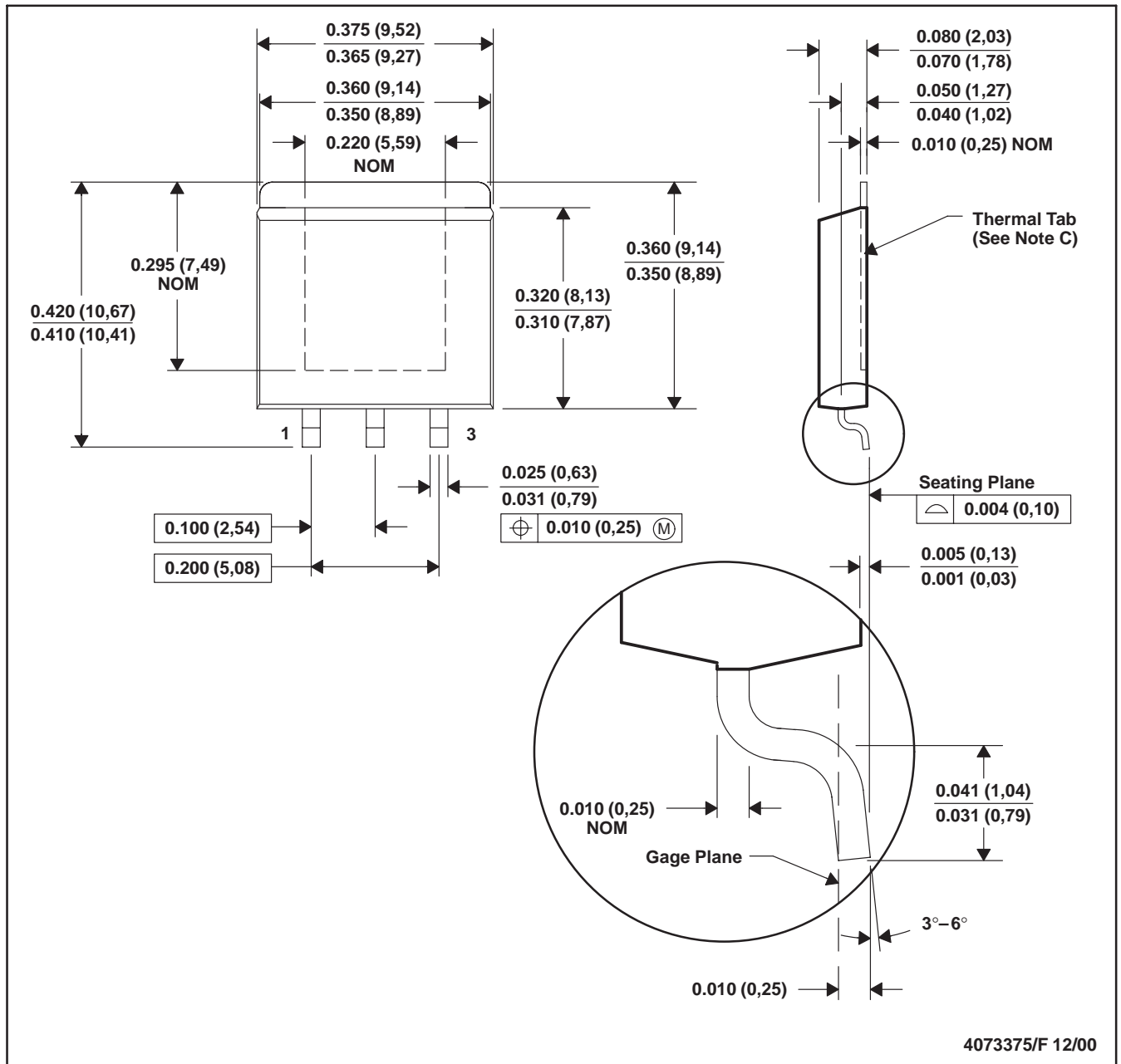

- NOTES: A. All linear dimensions are in inches (millimeters).  
 B. This drawing is subject to change without notice.  
 C. The center lead is in electrical contact with the thermal tab.  
 D. Dimensions do not include mold protrusions, not to exceed 0.006 (0,15).  
 E. Falls within JEDEC MO-169

PowerFLEX is a trademark of Texas Instruments.



KTP (R-PSFM-G2)

PowerFLEX™ PLASTIC FLANGE-MOUNT PACKAGE

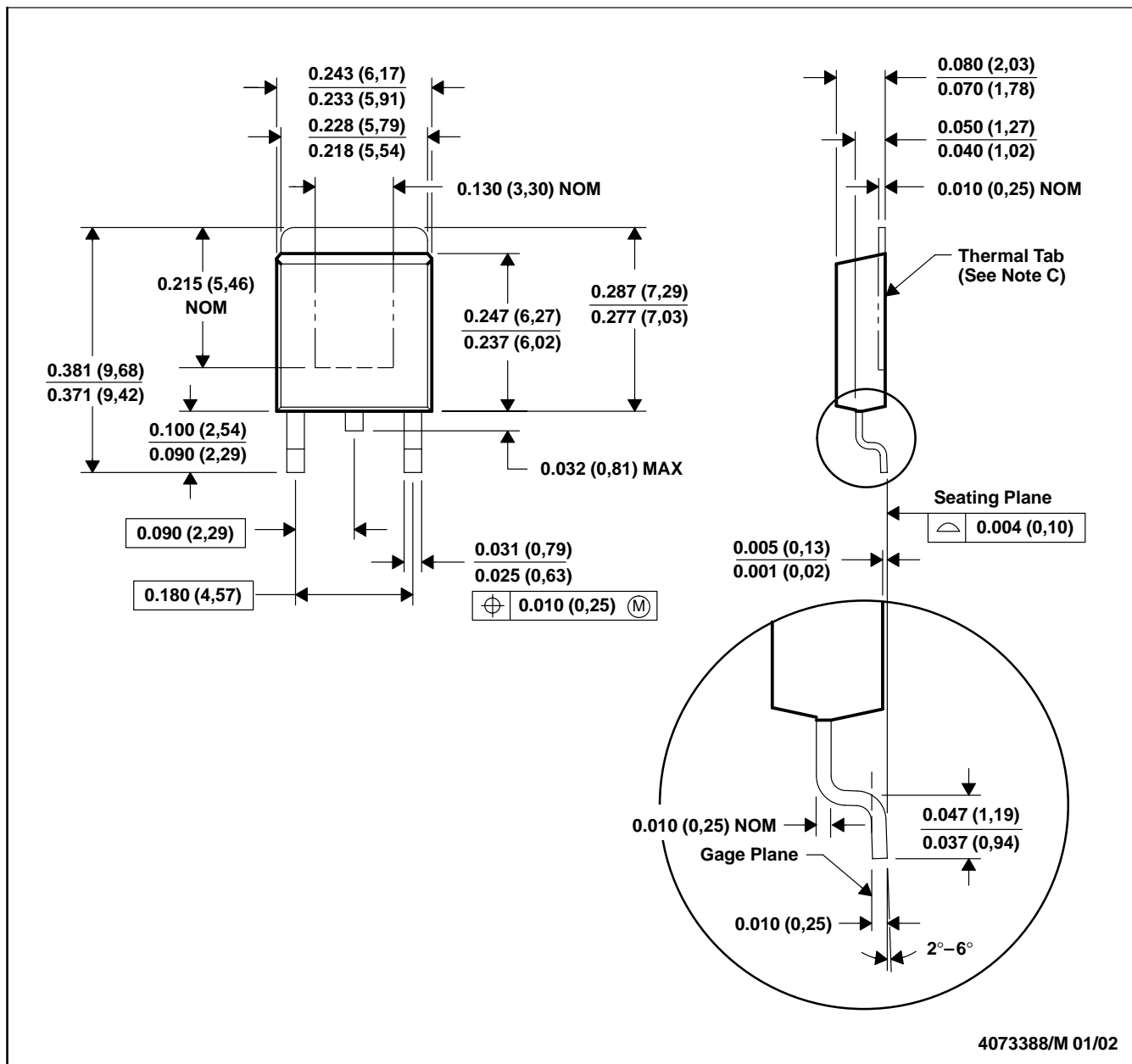

- NOTES: A. All linear dimensions are in inches (millimeters).  
 B. This drawing is subject to change without notice.  
 C. The center lead is in electrical contact with the thermal tab.  
 D. Dimensions do not include mold protrusions, not to exceed 0.006 (0,15).  
 E. Falls within JEDEC TO-252 variation AC.

PowerFLEX is a trademark of Texas Instruments.



KTT (R-PSFM-G3)

PLASTIC FLANGE-MOUNT PACKAGE

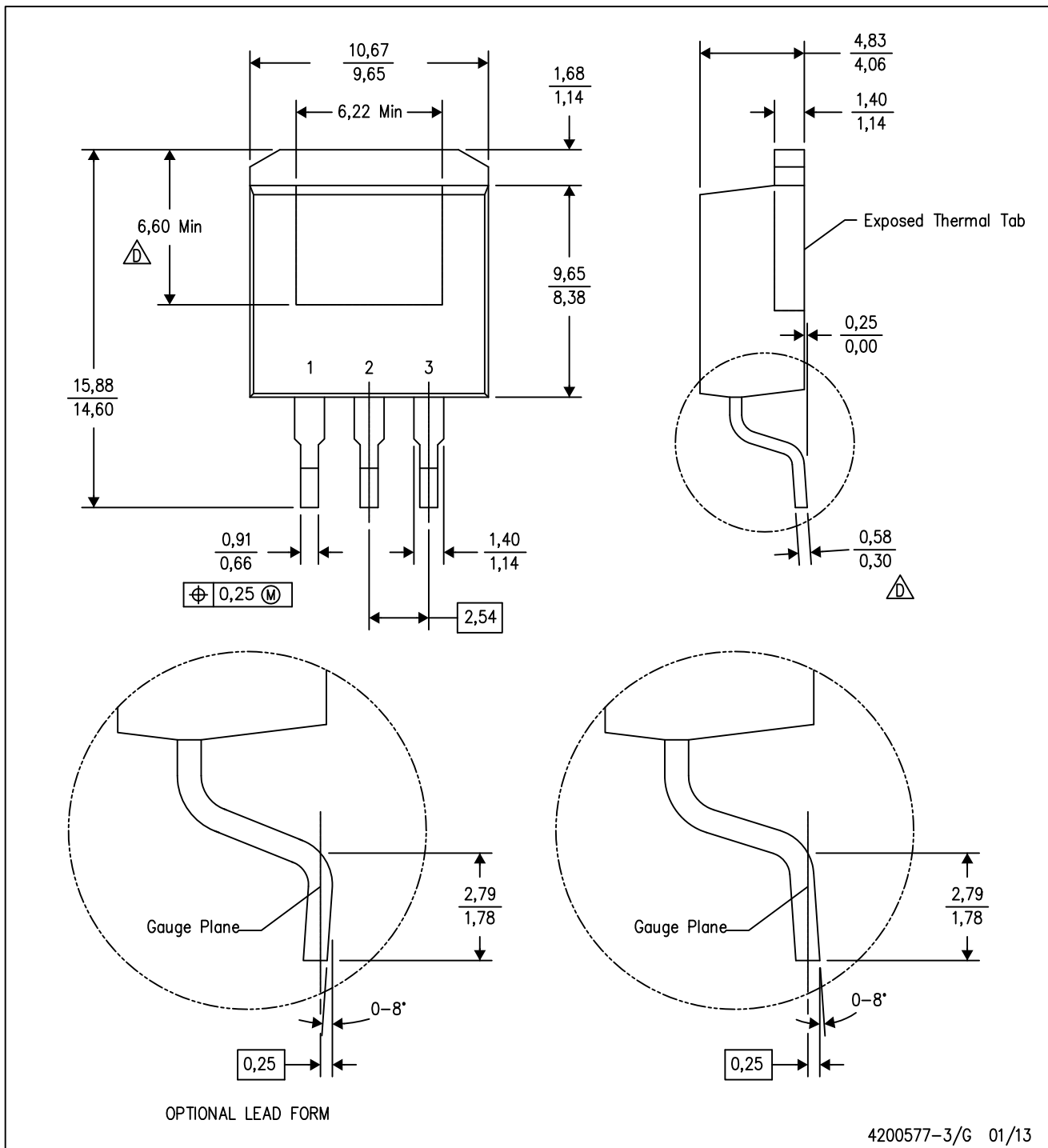

- NOTES:
- A. All linear dimensions are in millimeters.
  - B. This drawing is subject to change without notice.
  - C. Body dimensions do not include mold flash or protrusion. Mold flash or protrusion not to exceed 0.005 (0,13) per side.
  - (D) Falls within JEDEC TO-263 variation AA, except minimum lead thickness and minimum exposed pad length.

KTT (R-PSFM-G3)

PLASTIC FLANGE-MOUNT PACKAGE

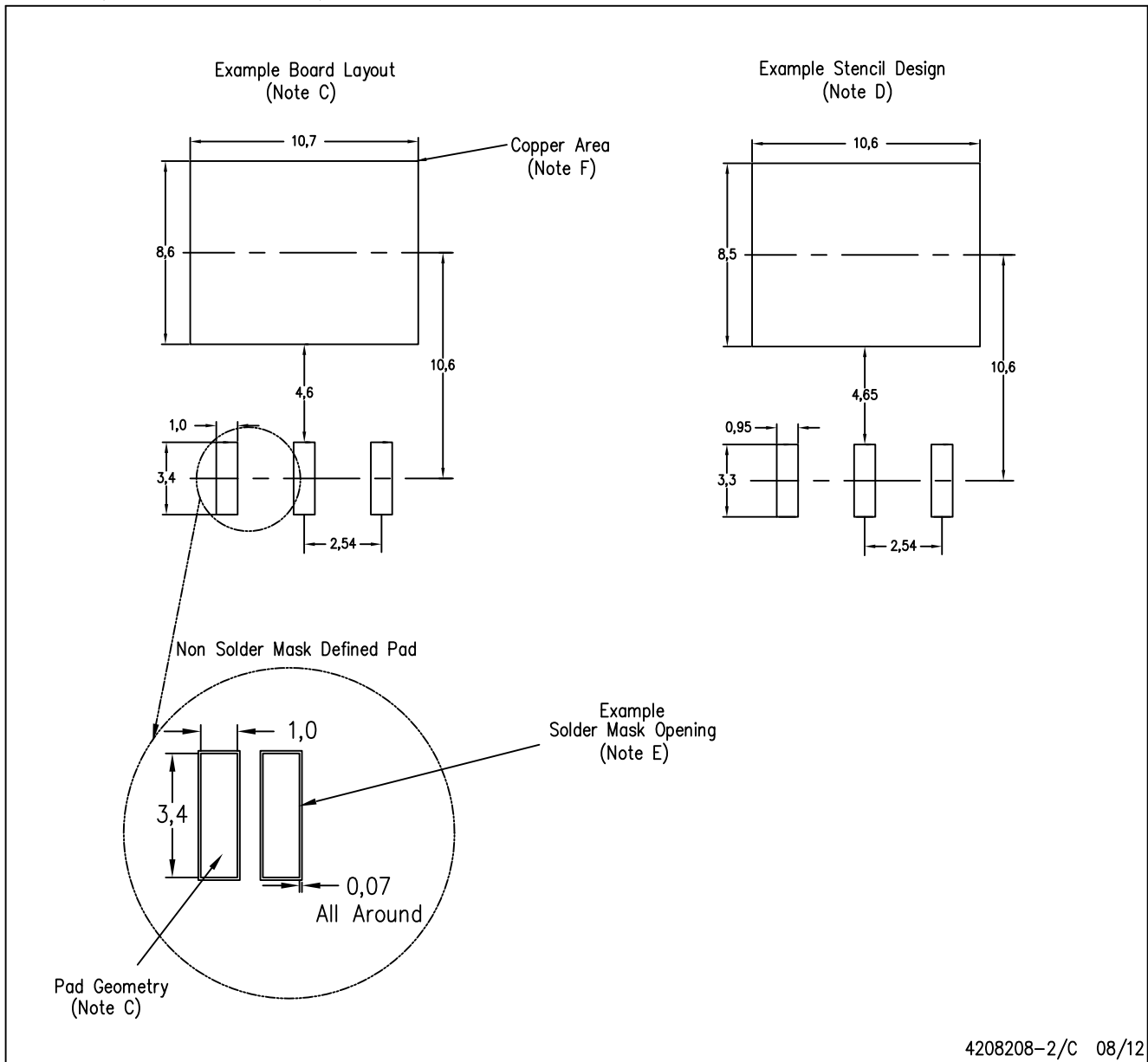

- NOTES:
- All linear dimensions are in millimeters.
  - This drawing is subject to change without notice.
  - Publication IPC-SM-782 is recommended for alternate designs.
  - Laser cutting apertures with trapezoidal walls and also rounding corners will offer better paste release. Customers should contact their board assembly site for stencil design recommendations. Refer to IPC-7525.
  - Customers should contact their board fabrication site for solder mask tolerances between and around signal pads.
  - This package is designed to be soldered to a thermal pad on the board. Refer to the Product Datasheet for specific thermal information, via requirements, and recommended thermal pad size. For thermal pad sizes larger than shown a solder mask defined pad is recommended in order to maintain the solderable pad geometry while increasing copper area.

KCS (R-PSFM-T3)

PLASTIC FLANGE-MOUNT PACKAGE

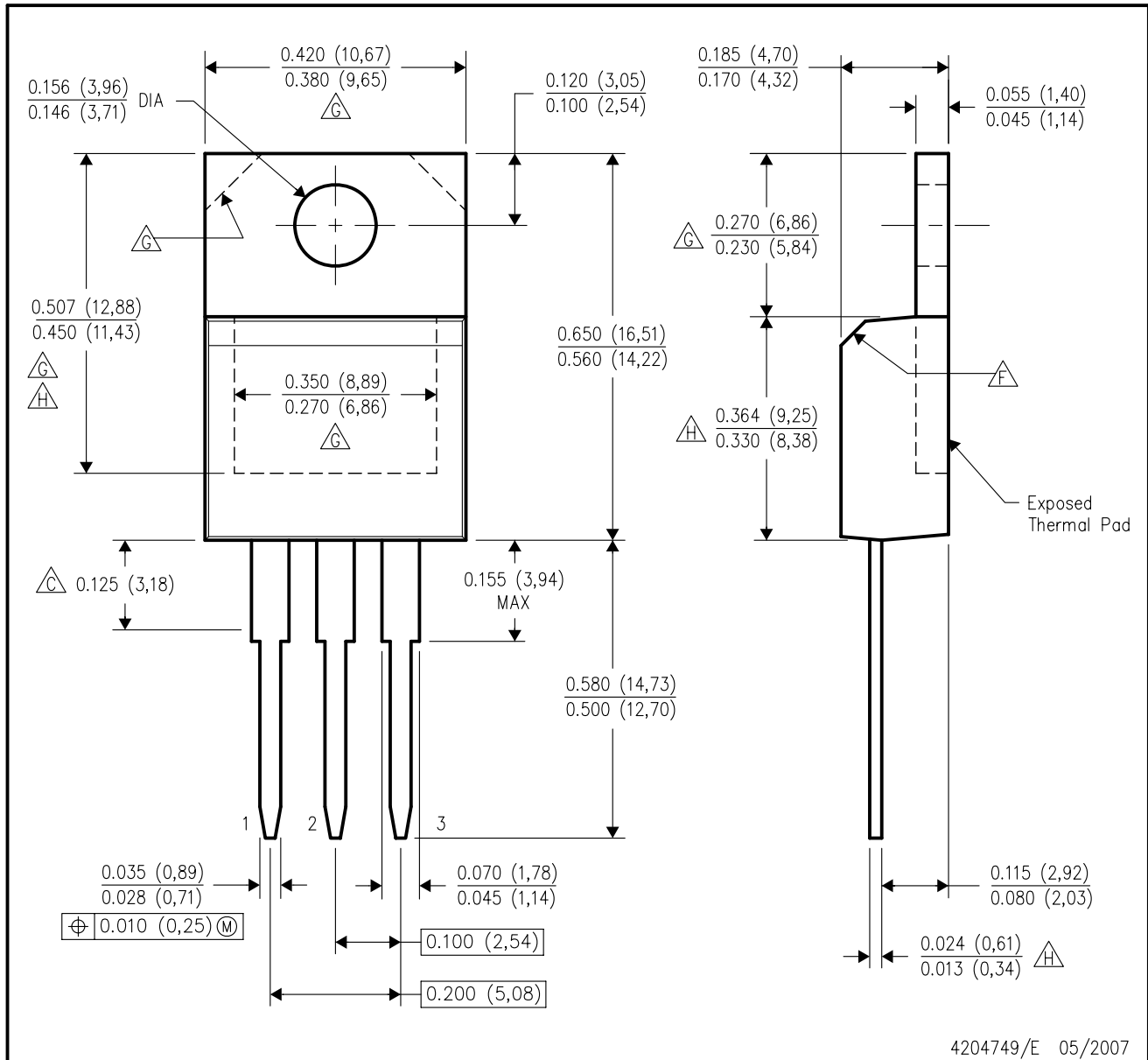



- NOTES:
- A. All linear dimensions are in inches (millimeters).
  - B. This drawing is subject to change without notice.
  - $\triangle C$  Lead dimensions are not controlled within this area.
  - D. All lead dimensions apply before solder dip.
  - E. The center lead is in electrical contact with the mounting tab.
  - $\triangle F$  The chamfer is optional.
  - $\triangle G$  Thermal pad contour optional within these dimensions.
  - $\triangle H$  Falls within JEDEC TO-220 variation AB, except minimum lead thickness, minimum exposed pad length, and maximum body length.

# MECHANICAL DATA

KVU (R-PSFM-G3)

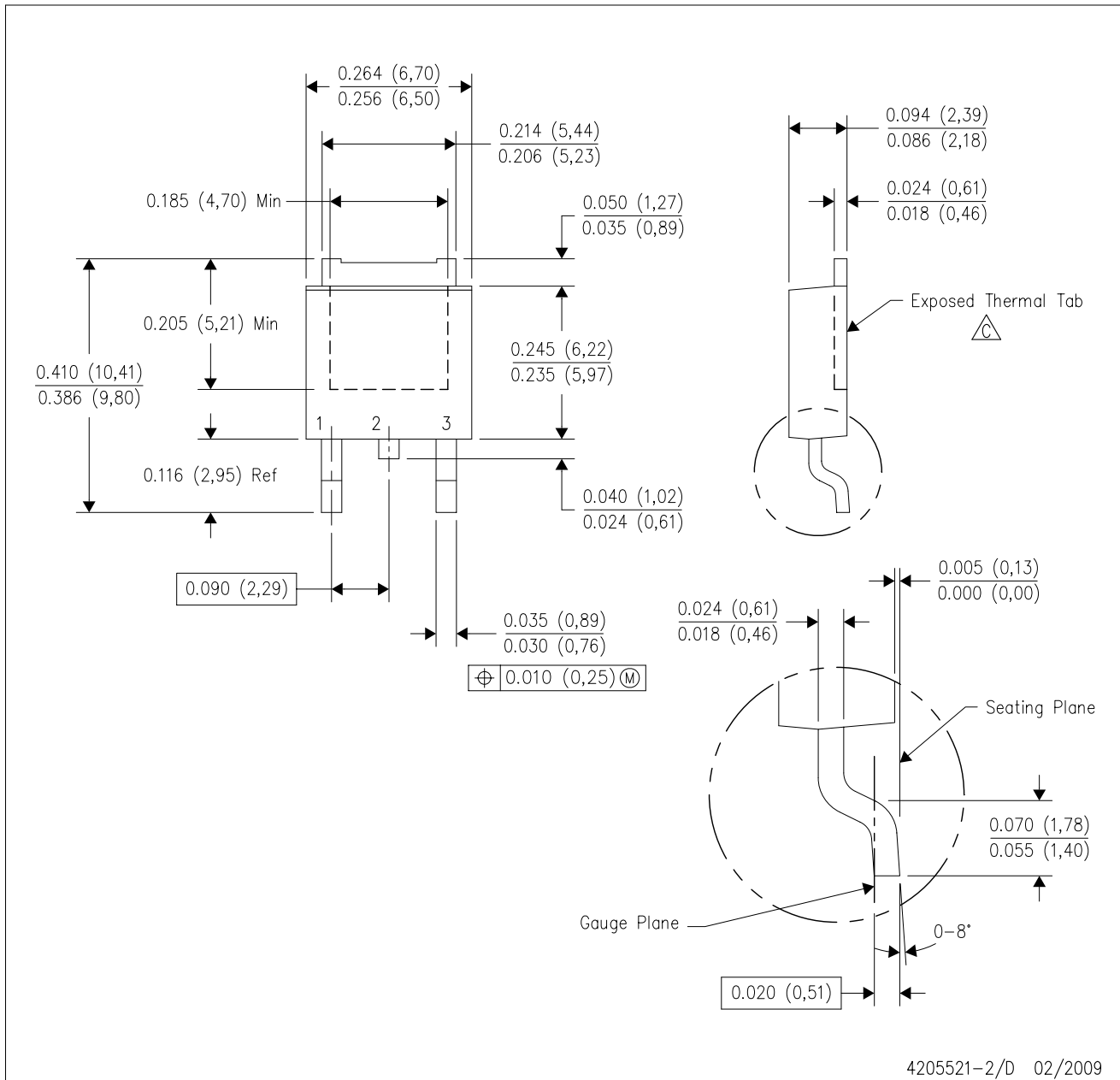
PLASTIC FLANGE-MOUNT PACKAGE



- NOTES:
- A. All linear dimensions are in inches (millimeters).
  - B. This drawing is subject to change without notice.
  -  The center lead is in electrical contact with the exposed thermal tab.
  - D. Body Dimensions do not include mold flash or protrusions. Mold flash and protrusion shall not exceed 0.006 (0,15) per side.
  - E. Falls within JEDEC TO-252 variation AA.

KVU (R-PSFM-G3)

PLASTIC FLANGE MOUNT PACKAGE

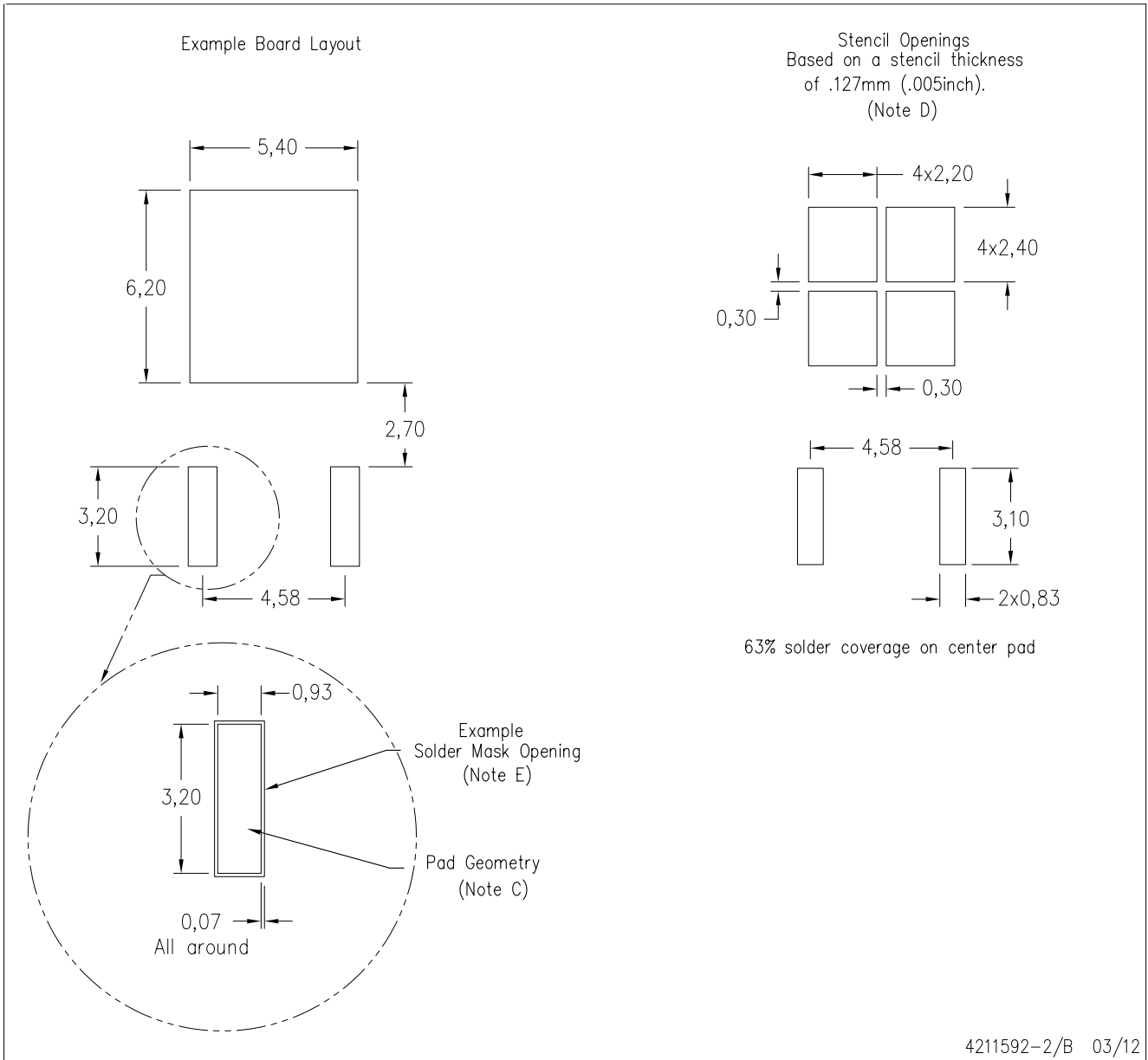

- NOTES:
- A. All linear dimensions are in millimeters.
  - B. This drawing is subject to change without notice.
  - C. Publication IPC-SM-782 is an alternate information source for PCB land pattern designs.
  - D. Laser cutting apertures with trapezoidal walls and also rounding corners will offer better paste release. Customers should contact their board assembly site for stencil design recommendations. Refer to IPC-7525 for other stencil recommendations.
  - E. Customers should contact their board fabrication site for recommended solder mask tolerances and via tenting recommendations for vias placed in thermal pad.



## IMPORTANT NOTICE

Texas Instruments Incorporated and its subsidiaries (TI) reserve the right to make corrections, enhancements, improvements and other changes to its semiconductor products and services per JESD46, latest issue, and to discontinue any product or service per JESD48, latest issue. Buyers should obtain the latest relevant information before placing orders and should verify that such information is current and complete. All semiconductor products (also referred to herein as "components") are sold subject to TI's terms and conditions of sale supplied at the time of order acknowledgment.

TI warrants performance of its components to the specifications applicable at the time of sale, in accordance with the warranty in TI's terms and conditions of sale of semiconductor products. Testing and other quality control techniques are used to the extent TI deems necessary to support this warranty. Except where mandated by applicable law, testing of all parameters of each component is not necessarily performed.

TI assumes no liability for applications assistance or the design of Buyers' products. Buyers are responsible for their products and applications using TI components. To minimize the risks associated with Buyers' products and applications, Buyers should provide adequate design and operating safeguards.

TI does not warrant or represent that any license, either express or implied, is granted under any patent right, copyright, mask work right, or other intellectual property right relating to any combination, machine, or process in which TI components or services are used. Information published by TI regarding third-party products or services does not constitute a license to use such products or services or a warranty or endorsement thereof. Use of such information may require a license from a third party under the patents or other intellectual property of the third party, or a license from TI under the patents or other intellectual property of TI.

Reproduction of significant portions of TI information in TI data books or data sheets is permissible only if reproduction is without alteration and is accompanied by all associated warranties, conditions, limitations, and notices. TI is not responsible or liable for such altered documentation. Information of third parties may be subject to additional restrictions.

Resale of TI components or services with statements different from or beyond the parameters stated by TI for that component or service voids all express and any implied warranties for the associated TI component or service and is an unfair and deceptive business practice. TI is not responsible or liable for any such statements.

Buyer acknowledges and agrees that it is solely responsible for compliance with all legal, regulatory and safety-related requirements concerning its products, and any use of TI components in its applications, notwithstanding any applications-related information or support that may be provided by TI. Buyer represents and agrees that it has all the necessary expertise to create and implement safeguards which anticipate dangerous consequences of failures, monitor failures and their consequences, lessen the likelihood of failures that might cause harm and take appropriate remedial actions. Buyer will fully indemnify TI and its representatives against any damages arising out of the use of any TI components in safety-critical applications.

In some cases, TI components may be promoted specifically to facilitate safety-related applications. With such components, TI's goal is to help enable customers to design and create their own end-product solutions that meet applicable functional safety standards and requirements. Nonetheless, such components are subject to these terms.

No TI components are authorized for use in FDA Class III (or similar life-critical medical equipment) unless authorized officers of the parties have executed a special agreement specifically governing such use.

Only those TI components which TI has specifically designated as military grade or "enhanced plastic" are designed and intended for use in military/aerospace applications or environments. Buyer acknowledges and agrees that any military or aerospace use of TI components which have **not** been so designated is solely at the Buyer's risk, and that Buyer is solely responsible for compliance with all legal and regulatory requirements in connection with such use.

TI has specifically designated certain components as meeting ISO/TS16949 requirements, mainly for automotive use. In any case of use of non-designated products, TI will not be responsible for any failure to meet ISO/TS16949.

### Products

Audio	<a href="http://www.ti.com/audio">www.ti.com/audio</a>
Amplifiers	<a href="http://amplifier.ti.com">amplifier.ti.com</a>
Data Converters	<a href="http://dataconverter.ti.com">dataconverter.ti.com</a>
DLP® Products	<a href="http://www.dlp.com">www.dlp.com</a>
DSP	<a href="http://dsp.ti.com">dsp.ti.com</a>
Clocks and Timers	<a href="http://www.ti.com/clocks">www.ti.com/clocks</a>
Interface	<a href="http://interface.ti.com">interface.ti.com</a>
Logic	<a href="http://logic.ti.com">logic.ti.com</a>
Power Mgmt	<a href="http://power.ti.com">power.ti.com</a>
Microcontrollers	<a href="http://microcontroller.ti.com">microcontroller.ti.com</a>
RFID	<a href="http://www.ti-rfid.com">www.ti-rfid.com</a>
OMAP Applications Processors	<a href="http://www.ti.com/omap">www.ti.com/omap</a>
Wireless Connectivity	<a href="http://www.ti.com/wirelessconnectivity">www.ti.com/wirelessconnectivity</a>

### Applications

Automotive and Transportation	<a href="http://www.ti.com/automotive">www.ti.com/automotive</a>
Communications and Telecom	<a href="http://www.ti.com/communications">www.ti.com/communications</a>
Computers and Peripherals	<a href="http://www.ti.com/computers">www.ti.com/computers</a>
Consumer Electronics	<a href="http://www.ti.com/consumer-apps">www.ti.com/consumer-apps</a>
Energy and Lighting	<a href="http://www.ti.com/energy">www.ti.com/energy</a>
Industrial	<a href="http://www.ti.com/industrial">www.ti.com/industrial</a>
Medical	<a href="http://www.ti.com/medical">www.ti.com/medical</a>
Security	<a href="http://www.ti.com/security">www.ti.com/security</a>
Space, Avionics and Defense	<a href="http://www.ti.com/space-avionics-defense">www.ti.com/space-avionics-defense</a>
Video and Imaging	<a href="http://www.ti.com/video">www.ti.com/video</a>

### TI E2E Community

[e2e.ti.com](http://e2e.ti.com)