

- **Drive Capability and Output Counts**
 - 80 mA (Current Sink) x 16 Bits
- **Constant Current Output Range**
 - 1 to 80 mA (Current Value Setting for All Output Terminals Using External Resistor)
- **Constant Current Accuracy**
 - $\pm 1\%$ (Typ)
 - $\pm 4\%$ (Max) (Maximum Error Between Bits, All Bits On)
- **Voltage Applied to Constant Current Output Terminal**
 - Minimum 0.6 V (Output Current 40 mA)
 - Minimum 1 V (Output Current 80 mA)
- **Data Input**
 - Clock Synchronized 1 Bit Serial Input
- **Data Output**
 - Clock Synchronized 1 bit Serial Output (With Timing Selection)
- **Input/Output Signal Level . . . CMOS Level**
- **Power Supply Voltage . . . 4.5 V to 5.5V**
- **Maximum Output Voltage . . . 17 V (Max)**
- **Data Transfer Rate . . . 20 MHz (Max)**
- **Operating Free-Air Temperature Range**
–20°C to 85°C
- **Available in 32 Pin HTSSOP DAP Package**
($P_D=3.9$ W,
 $T_A = 25^\circ\text{C}$)
- **LOD Function . . . LED Open Detection**
(Error Signal Output at LED Disconnection)
- **TSD Function . . . Thermal Shutdown (Turn Output Off When Junction Temperature Exceeds Limit)**

**DAP PACKAGE
(TOP VIEW)**

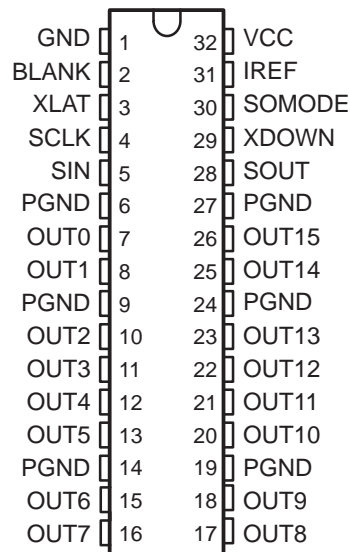

description

The TLC5921 is a current-sink constant current driver incorporating shift register and data latch. The current value at constant current output can be set by one external register. The device also incorporates thermal shutdown (TSD) circuitry which turns constant current output off when the junction temperature exceeds the limit, and LED open detection (LOD) circuitry to report the LED was disconnected.



Please be aware that an important notice concerning availability, standard warranty, and use in critical applications of Texas Instruments semiconductor products and disclaimers thereto appears at the end of this data sheet.

TLC5921 LED DRIVER

SLLS390 – SEPTEMBER 1999

functional block diagram

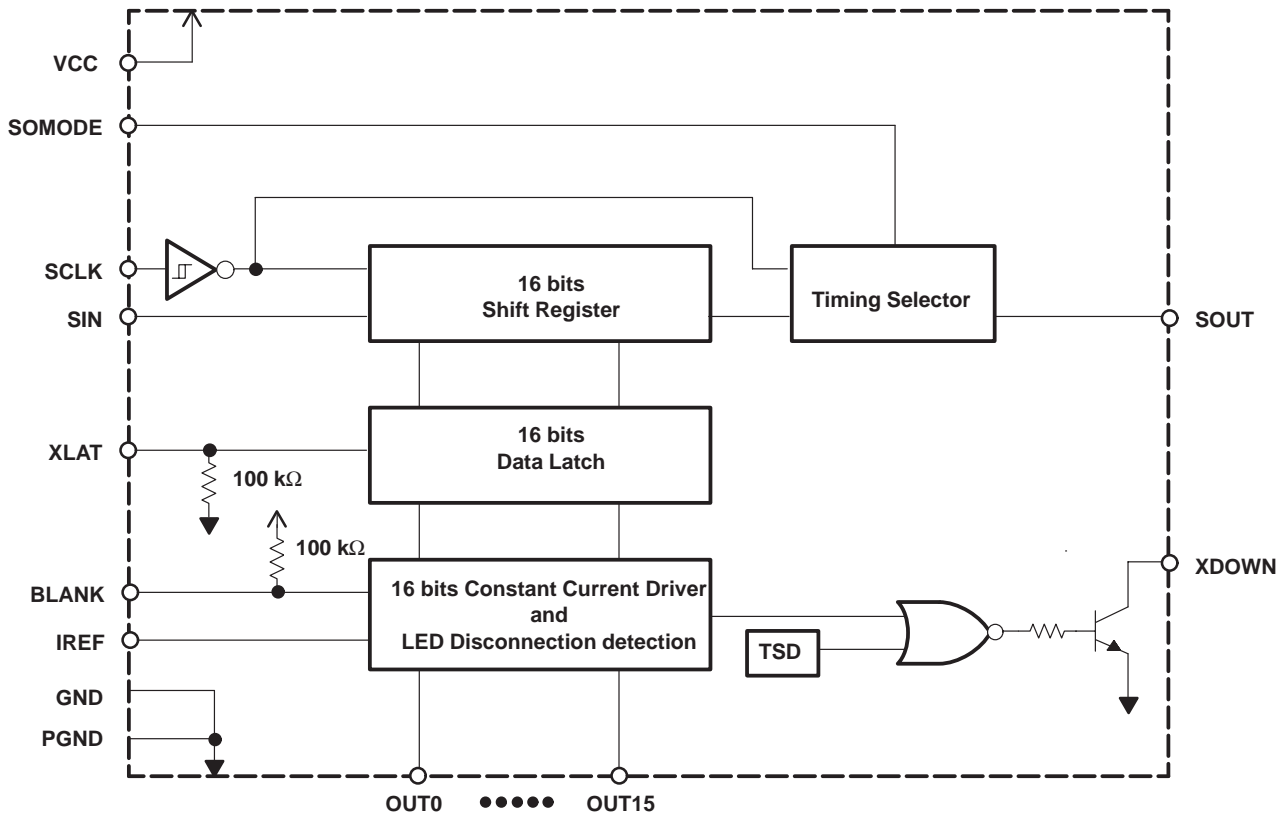

equivalent input and output schematic diagrams

Input (except SCLK)

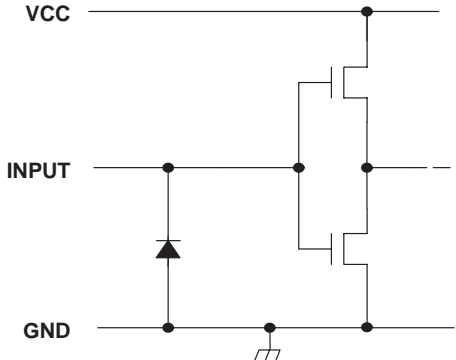

Input (SCLK)

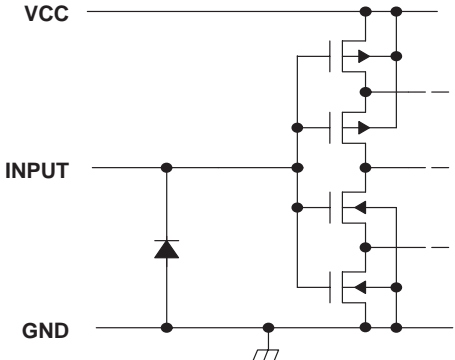

SOUT

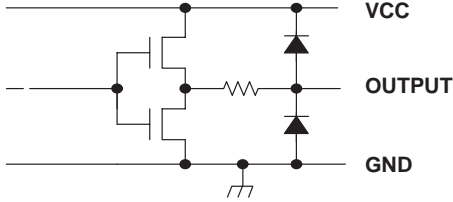

XDOWN

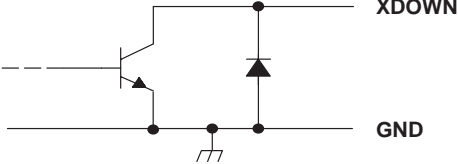

OUTn

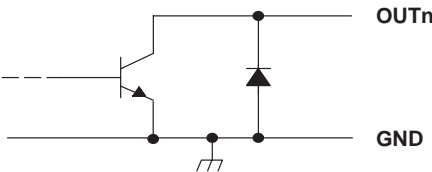

TLC5921 LED DRIVER

SLLS390 – SEPTEMBER 1999

Terminal Functions

TERMINAL		I/O	DESCRIPTION
NAME	NO.		
SIN	5	I	1 bit serial data input
SOUT	28	O	1 bit serial data output
SCLK	4	I	Clock input for data transfer. All the data in the shift register is shifted to MSB by 1 bit synchronizing to the rising edge of SCLK, and data at SIN is shifted to LSB at the same time. (Schmitt buffer input)
XLAT	3	I	Latch. When XLAT is high, data on shift register goes through latch. When XLAT is low, data is latched. Accordingly, if data on shift register is changed during XLAT high, this new value is latched (level latch). This terminal is internally pulled down with 100kΩ.
SOMODE	30	I	Timing select for serial data output. When SOMODE is low, output data on SOUT is changed synchronizing to the rising edge of SCLK. When SOMODE is high, output data on SOUT is changed synchronizing to the falling edge of SCLK.
OUT0 – OUT15	7,8,10,11,12,13, 15,16,17,18,20, 21,22,23,25,26	O	Constant current output.
BLANK	2	I	Blank(Light off). When BLANK is high, all the output of constant current driver is turned off. When BLANK is low and data written to latch is 1, the corresponding constant current output turns on (LED on). This terminal is internally pulled up with 100kΩ.
IREF	31	I	Constant current value setting. LED current is set to desired value by connecting external resistor between IREF and GND. The 38 times current compared to current across external resistor sink on output terminal.
XDOWN	29	O	Error output. XDOWN is configured as open collector. It goes low when TSD or LOD functions.
VCC	32		Power supply voltage
GND	1		Ground
PGND	6,9,14,19,24,27		Ground for LED driver. (Internally connected to GND)
THERMAL PAD	package bottom		Heat sink pad. This pad is connected to the lowest potential to IC or thermal layer.

absolute maximum ratings (see Note 1)†

Supply voltage, V_{CC}	– 0.3 V to 7 V
Output current (dc), $I_{O(LC)}$	90 mA
Input voltage range, V_I	– 0.3 V to $V_{CC} + 0.3$ V
Output voltage range, $V_O(SOUT)$, $V_O(XDOWN)$	– 0.3 V to $V_{CC} + 0.3$ V
Output voltage range, $V_O(OUTn)$	– 0.3 V to 18 V
Storage temperature range, T_{stg}	–40°C to 150°C
Continuous total power dissipation at (or below) $T_A = 25^\circ\text{C}$	3.9 W
Power dissipation rating at (or above) $T_A = 25^\circ\text{C}$	31.4 mW/°C

† Stresses beyond those listed under “absolute maximum ratings” may cause permanent damage to the device. These are stress ratings only, and functional operation of the device at these or any other conditions beyond those indicated under “recommended operating conditions” is not implied. Exposure to absolute-maximum-rated conditions for extended periods may affect device reliability.

NOTE 1: All voltage values are with respect to GND terminal.



recommended operating conditions

dc characteristics

PARAMETER	CONDITIONS	MIN	NOM	MAX	UNIT
Supply voltage, V_{CC}		4.5	5	5.5	V
Voltage applied to constant current output, V_O	OUT0 to OUT15 off			17	V
High-level input voltage, V_{IH}		0.8 V_{CC}		V_{CC}	V
Low-level input voltage, V_{IL}		GND		0.2 V_{CC}	V
High-level output current, I_{OH}	$V_{CC} = 4.5$ V, SOUT			-1	mA
Low-level output current, I_{OL}	$V_{CC} = 4.5$ V, SOUT, XDOWN			1	
Constant output current, $I_{O(LC)}$	OUT0 to OUT15			80	mA
Operating free-air temperature range, T_A		-20		85	°C

**ac characteristics, MIN/MAX: $V_{CC} = 4.5$ V to 5.5 V, $T_A = -20$ to 85°C
TYP: $V_{CC} = 5$ V, $T_A = 25^\circ\text{C}$ (unless otherwise noted)**

PARAMETER	CONDITIONS	MIN	TYP	MAX	UNIT
f_{SCLK} SCLK clock frequency	At single operation			20	MHz
	At cascade operation (SOMODE = L)			15	
t_{wh}/t_{wl} SCLK pulse duration		20			ns
t_{wh} XLAT pulse duration		10			ns
t_r/t_f Rise/fall time				100	ns
t_{su} Setup time	SIN – SCLK	5			ns
	XLAT – SCLK	5			
t_h Hold time	SIN – SCLK	20			ns
	XLAT – SCLK	20			

TLC5921 LED DRIVER

SLLS390 – SEPTEMBER 1999

electrical characteristics, MIN/MAX: $V_{CC} = 4.5\text{ V to }5.5\text{ V}$, $T_A = -20\text{ to }85^\circ\text{C}$
TYP: $V_{CC} = 5\text{ V}$, $T_A = 25^\circ\text{C}$ (unless otherwise noted)

PARAMETER		TEST CONDITIONS	MIN	TYP	MAX	UNIT
V_{OH}	High-level output voltage	$I_{OH} = -1\text{ mA}$	V_{CC} -0.5 V			V
V_{OL}	Low-level output voltage	$I_{OL} = 1\text{ mA}$			0.5	V
I_I	Input current	$V_I = V_{CC}$ or GND (except BLANK, XLAT)			± 1	μA
I_{CC}	Supply current	Input signal is static, $V_O = 1\text{ V}$, $R_{(IREF)} = 10\text{ k}\Omega$, All output bits turn off		3	4.5	mA
		Input signal is static, $V_O = 1\text{ V}$, $R_{(IREF)} = 1300\ \Omega$, All output bits turn off		7	9	
		Input signal is static, $V_O = 1\text{ V}$, $R_{(IREF)} = 640\ \Omega$, All output bits turn off		11	15	
		Data transfer, $V_O = 1\text{ V}$, $R_{(IREF)} = 1300\ \Omega$, All output bits turn on		15	20	
		Data transfer, $V_O = 1\text{ V}$, $R_{(IREF)} = 640\ \Omega$, All output bits turn on		35	50	
$I_{OL(C1)}$	Constant output current	$V_O = 1\text{ V}$, $R_{(IREF)} = 1300\ \Omega$	35	40	45	mA
$I_{OL(C2)}$	Constant output current	$V_O = 1\text{ V}$, $R_{(IREF)} = 640\ \Omega$	70	80	90	mA
I_{lkg}	Constant output leakage current	OUT0 to OUT15 ($V_{(OUTn)} = 15\text{ V}$)			0.1	μA
		XDOWN (5V pullup)			1	μA
$\Delta I_{O(LC)}$	Constant output current error between bit	$V_O = 1\text{ V}$, $R_{(IREF)} = 640\ \Omega$, All output bits turn on		± 1	± 4	%
$\Delta I_{O(LC1)}$	Changes in constant output current depend on supply voltage	$V_{ref} = 1.3\text{ V}$		± 1	± 4	%/V
$\Delta I_{O(LC2)}$	Changes in constant output current depend on output voltage	$V_O = 1\text{ V to }3\text{ V}$, $R_{(IREF)} = 1300\ \Omega$, $V_{ref} = 1.3\text{ V}$, 1 bit output turn on		± 2	± 6	%/V
$T_{(tsd)}$	TSD detection temperature	Junction temperature	150	160	170	$^\circ\text{C}$
V_{ref}	Reference voltage	$R_{(IREF)} = 640\ \Omega$		1.3		V
$V_{(LEDDT)}$	LED disconnection detection voltage			0.3		V

switching characteristics, $C_L = 15\text{ pF}$

PARAMETER		TEST CONDITIONS	MIN	TYP	MAX	UNIT
t_r	Rise time	SOUT		15	20	ns
		OUTn (see Figure 1)		300		
t_f	Fall time	SOUT		5	15	ns
		OUTn		300		
t_{pd}	Propagation delay time	BLANK \uparrow – OUTn		400	650	ns
		BLANK \downarrow – OUTn		300	400	
		BLANK \uparrow – XDOWN (see Note 2)		600	1000	
		BLANK \downarrow – XDOWN (see Note 2)		500	1000	
		SCLK – SOUT	10	20	35	

NOTE 2: At external resistor 5 k Ω



PARAMETER MEASUREMENT INFORMATION

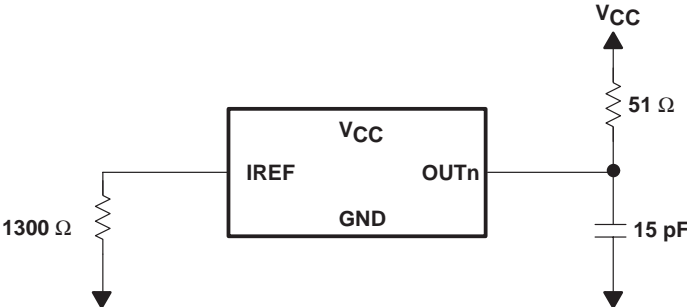

Figure 1. Rise Time and Fall Time Test Circuit for OUTn

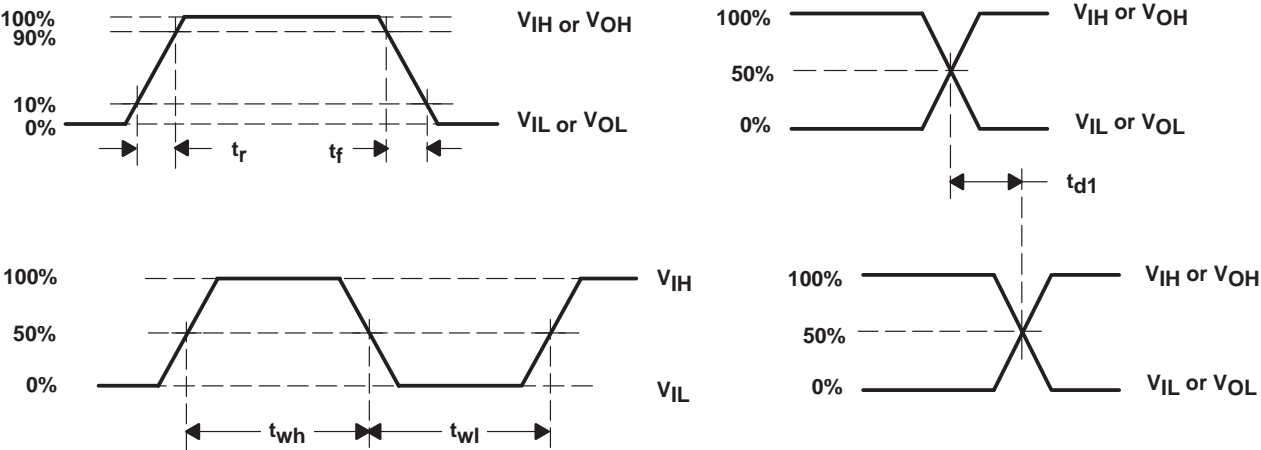

Figure 2. Timing Requirements

PRINCIPLES OF OPERATION

setting for constant output current value

The constant current value is determined by external resistor, $R_{(IREF)}$ between IREF and GND. Refer constant output current characteristics shown on Figure 5 for this external resistor value.

Note that more current flows if connect IREF to GND directly.

constant output current operation

When BLANK is low, the corresponding output is turned on if data latch value is 1, and turned off if data latch value is 0. When BLANK is high, all outputs are forced to turn off. If there is constant current output terminal left unconnected (includes LED disconnection), it should be lighted on after writing zero to corresponding data latch to its output. If this operation is not done, supply current through constant current driver will increase.

shift register latch

The shift register latch is configured with 16×1 bits. The 1 bit for constant current output data represents ON for constant current output if data is 1, or OFF if data is 0. The configuration of shift register latch is shown in below.

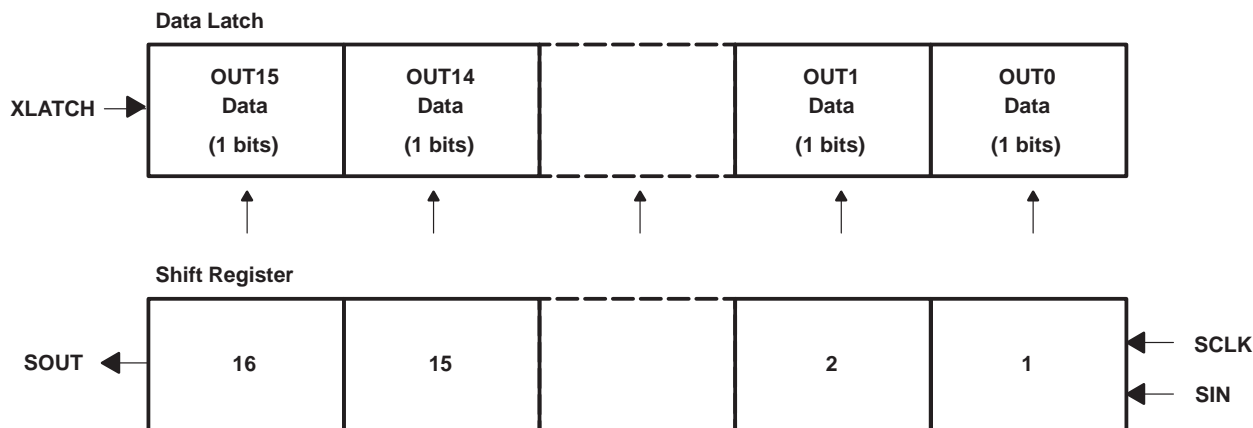

Figure 3. Relationship Between Shift Register and Latch

SOUT output timing selection

By setting level of SOMODE, the SOUT output timing can be changed. When SOMODE is set to low, data is clocked out to SOUT synchronized on the rising edge of SCLK, and when SOMODE is set to high, data is clocked out to SOUT synchronized on the falling edge of SCLK. When SOMODE is set to high and shift operation is done, the data shift error can be prevented even though SCLK signal is externally buffered in serial. Note that the maximum data transfer rate in cascade operation is slower than that when SMODE is set to low.

TSD (thermal shutdown)

When the junction temperature exceeds the limit, TSD starts to function and turn constant current output off and XDOWN goes low. Since XDOWN is configured with open-collector output, the outputs of multiple ICs can be concatenated. To recover from constant current output off-state to normal operation, power supply should be turned off and then turned on after several seconds.

PRINCIPLES OF OPERATION

LOD function (LED open detection)

If any terminal voltage of constant current output (OUT0 TO 15) to be turned on is approximately below 0.3 V, XDOWN output goes low during output on by knowing LED disconnection. This function is operational for sixteen OUTn individually. To know which constant current output is disconnected, the level of XDOWN is repeatedly checked 16 times from OUT0 to OUT15 turning one constant current output on. The power supply voltage for LED should be set to that the constant current output is applied to above 0.4 V to prevent from XDOWN low when LED is lighting on normally. Note that on-time should be minimum 1 μ s after the constant current output is turned on since XDOWN output is required approximately 1 μ s.

As discussed earlier, XDOWN is used for both TSD and LOD function. Therefore, BLANK is used to know which one of TSD or LOD worked when XDOWN went low at LED disconnection, that is, in this condition, when set BLANK to high, all the constant current outputs are turned off and LOD disconnection detection is disabled, then, if XDOWN was changed to high, LED disconnection must be occurred.

Table 1 is an example for XDOWN output status using four LEDs.

Table 1. XDOWN Output Example

LED NUMBER	1	2	3	4
LED STATUS	GOOD	NG	GOOD	NG
OUTn	ON	ON	ON	ON
DETECTION RESULT	GOOD	NG	GOOD	NG
XDOWN	LOW (by case 2, 4)			
LED NUMBER	1	2	3	4
LED STATUS	GOOD	NG	GOOD	NG
OUTn	ON	ON	OFF	OFF
DETECTION RESULT	GOOD	NG	GOOD	GOOD
XDOWN	LOW (by case 2)			
LED NUMBER	1	2	3	4
LED STATUS	GOOD	NG	GOOD	NG
OUTn	OFF	OFF	OFF	OFF
DETECTION RESULT	GOOD	GOOD	GOOD	GOOD
XDOWN2	HIGH-IMPEDANCE			

noise reduction : output slope

When output current is 80 mA, the time to change constant current output to turn-on and turn-off is approximately 150 ns and 250 ns respectively. This allows to reduce concurrent switching noise occurred when multiple outputs turn or off at the same time.

thermal pad

The thermal pad should be connected to GND to eliminate the noise influence since it is connected to the bottom side of IC chip. Also, desired thermal effect will be obtained by connecting this pad to the PCB pattern with better thermal conductivity.

PRINCIPLES OF OPERATION

power rating – free-air temperature

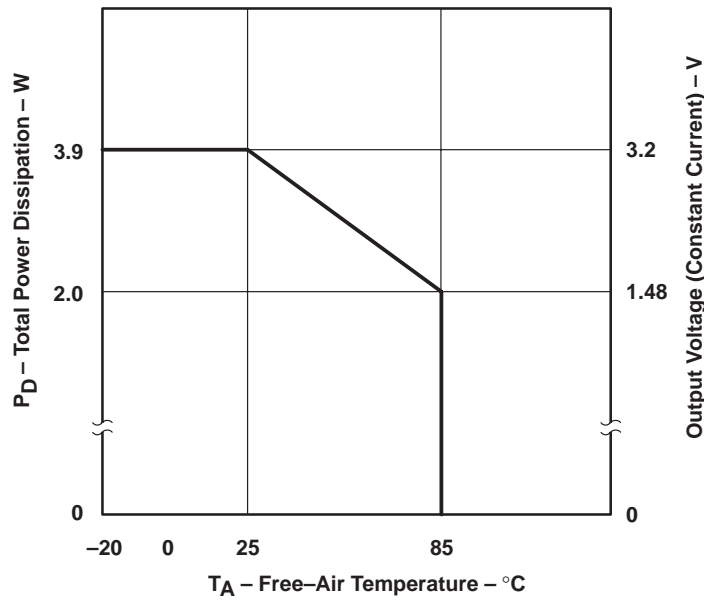

- NOTES: A. The data is based on simulation result. When TI recommended print circuit board is used, derate linearly at the rate of 31.4 mW/°C for operation above 25°C free-air temperature. VCC=5 V, IO(LC) = 80 mA, ICC is typical value.
- B. The thermal impedance will be varied depend on mounting conditions. Since PZP package established low thermal impedance by radiating heat from thermal pad, the thermal pad should be soldered to pattern with low thermal impedance.
- C. The material for PCB should be selected considering the thermal characteristics since the temperature will rise around the thermal pad.

Figure 4. Power Rating

PRINCIPLES OF OPERATION

constant output current

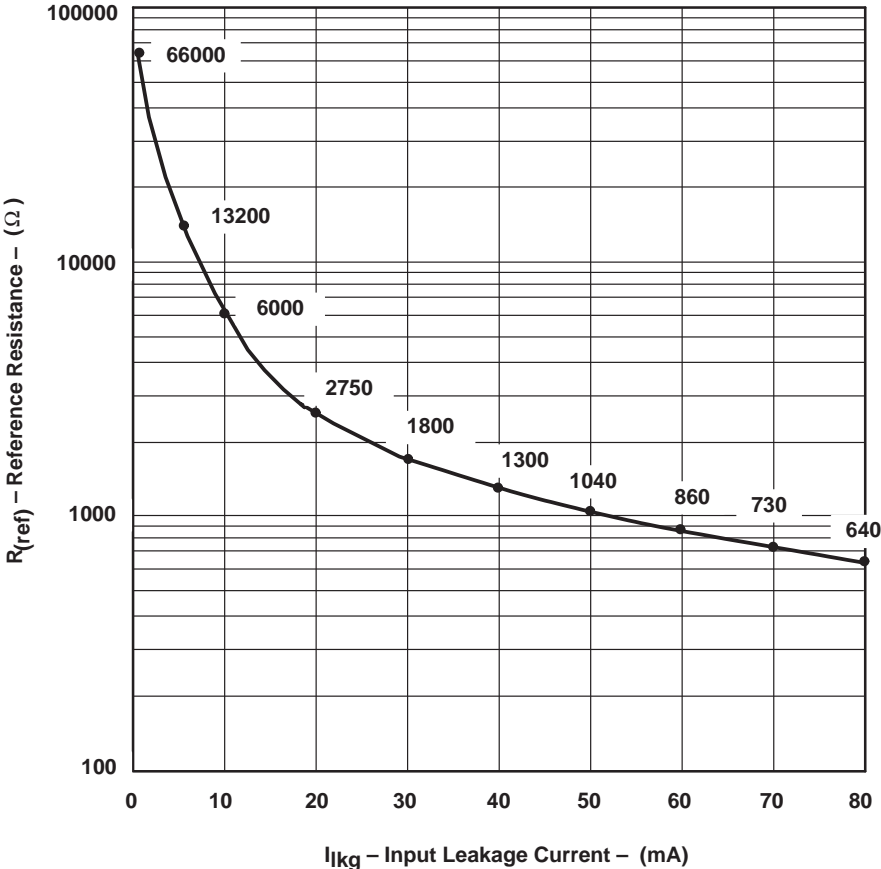

Conditions : $V_O = 1\text{ V}$, $V_{ref} = 1.3\text{ V}$

NOTE: The resistor, $R_{(IREF)}$, should be located as close to IREF terminal as possible to avoid the noise influence.

Figure 5. Current on Constant Current Output vs External Resistor

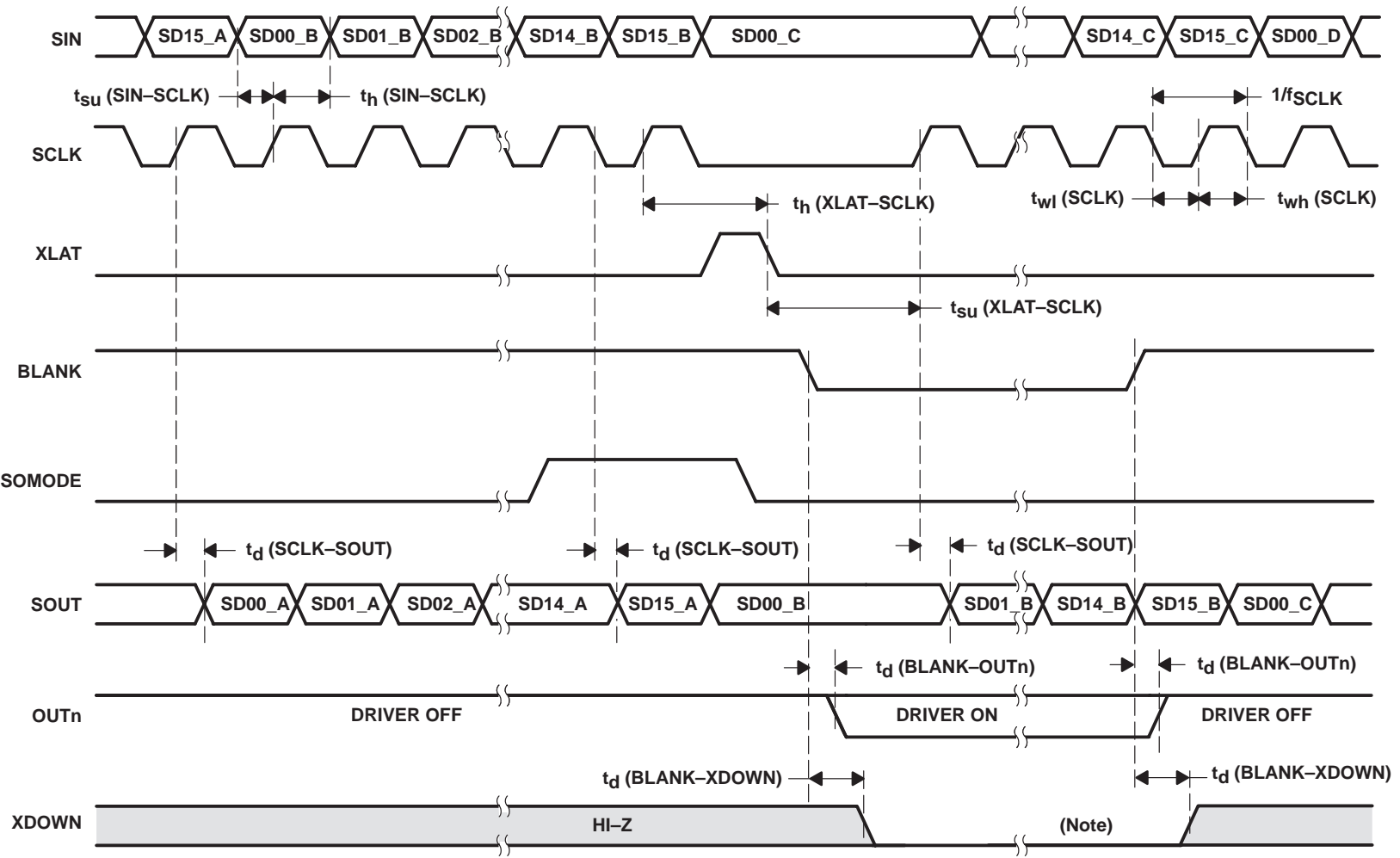

NOTE : LED disconnected

Figure 6. Timing Diagram

MECHANICAL DATA

DAP (R-PDSO-G**)

PowerPAD™ PLASTIC SMALL-OUTLINE PACKAGE

38 PINS SHOWN

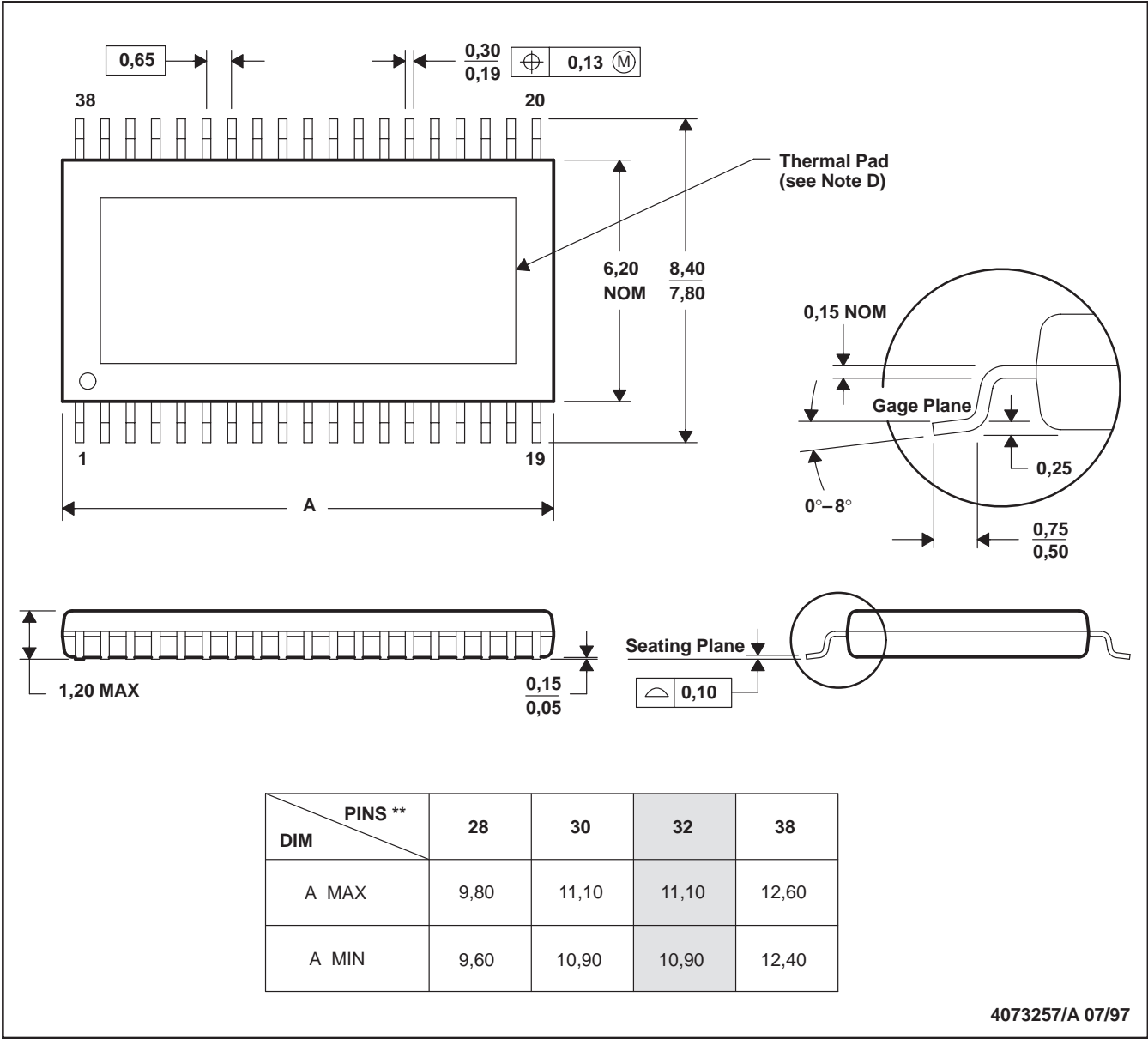

- NOTES: A. All linear dimensions are in millimeters.
 B. This drawing is subject to change without notice.
 C. Body dimensions do not include mold flash or protrusion.
 D. The package thermal performance may be enhanced by bonding the thermal pad to an external thermal plane. This pad is electrically and thermally connected to the backside of the die and possibly selected leads.
 E. Falls within JEDEC MO-153

PowerPAD is a trademark of Texas Instruments Incorporated.

PACKAGING INFORMATION

Orderable Device	Status ⁽¹⁾	Package Type	Package Drawing	Pins	Package Qty	Eco Plan ⁽²⁾	Lead/Ball Finish	MSL Peak Temp ⁽³⁾
TLC5921DAP	ACTIVE	HTSSOP	DAP	32	46	Green (RoHS & no Sb/Br)	CU NIPDAU	Level-3-260C-168 HR
TLC5921DAPG4	ACTIVE	HTSSOP	DAP	32	46	Green (RoHS & no Sb/Br)	CU NIPDAU	Level-3-260C-168 HR
TLC5921DAPR	ACTIVE	HTSSOP	DAP	32	2000	Green (RoHS & no Sb/Br)	CU NIPDAU	Level-3-260C-168 HR
TLC5921DAPRG4	ACTIVE	HTSSOP	DAP	32	2000	Green (RoHS & no Sb/Br)	CU NIPDAU	Level-3-260C-168 HR

⁽¹⁾ The marketing status values are defined as follows:

ACTIVE: Product device recommended for new designs.

LIFEBUY: TI has announced that the device will be discontinued, and a lifetime-buy period is in effect.

NRND: Not recommended for new designs. Device is in production to support existing customers, but TI does not recommend using this part in a new design.

PREVIEW: Device has been announced but is not in production. Samples may or may not be available.

OBSOLETE: TI has discontinued the production of the device.

⁽²⁾ Eco Plan - The planned eco-friendly classification: Pb-Free (RoHS), Pb-Free (RoHS Exempt), or Green (RoHS & no Sb/Br) - please check <http://www.ti.com/productcontent> for the latest availability information and additional product content details.

TBD: The Pb-Free/Green conversion plan has not been defined.

Pb-Free (RoHS): TI's terms "Lead-Free" or "Pb-Free" mean semiconductor products that are compatible with the current RoHS requirements for all 6 substances, including the requirement that lead not exceed 0.1% by weight in homogeneous materials. Where designed to be soldered at high temperatures, TI Pb-Free products are suitable for use in specified lead-free processes.

Pb-Free (RoHS Exempt): This component has a RoHS exemption for either 1) lead-based flip-chip solder bumps used between the die and package, or 2) lead-based die adhesive used between the die and leadframe. The component is otherwise considered Pb-Free (RoHS compatible) as defined above.

Green (RoHS & no Sb/Br): TI defines "Green" to mean Pb-Free (RoHS compatible), and free of Bromine (Br) and Antimony (Sb) based flame retardants (Br or Sb do not exceed 0.1% by weight in homogeneous material)

⁽³⁾ MSL, Peak Temp. -- The Moisture Sensitivity Level rating according to the JEDEC industry standard classifications, and peak solder temperature.

Important Information and Disclaimer:The information provided on this page represents TI's knowledge and belief as of the date that it is provided. TI bases its knowledge and belief on information provided by third parties, and makes no representation or warranty as to the accuracy of such information. Efforts are underway to better integrate information from third parties. TI has taken and continues to take reasonable steps to provide representative and accurate information but may not have conducted destructive testing or chemical analysis on incoming materials and chemicals. TI and TI suppliers consider certain information to be proprietary, and thus CAS numbers and other limited information may not be available for release.

In no event shall TI's liability arising out of such information exceed the total purchase price of the TI part(s) at issue in this document sold by TI to Customer on an annual basis.

DAP (R-PDSO-G**) 38 PINS SHOWN

PowerPAD™ PLASTIC SMALL-OUTLINE PACKAGE

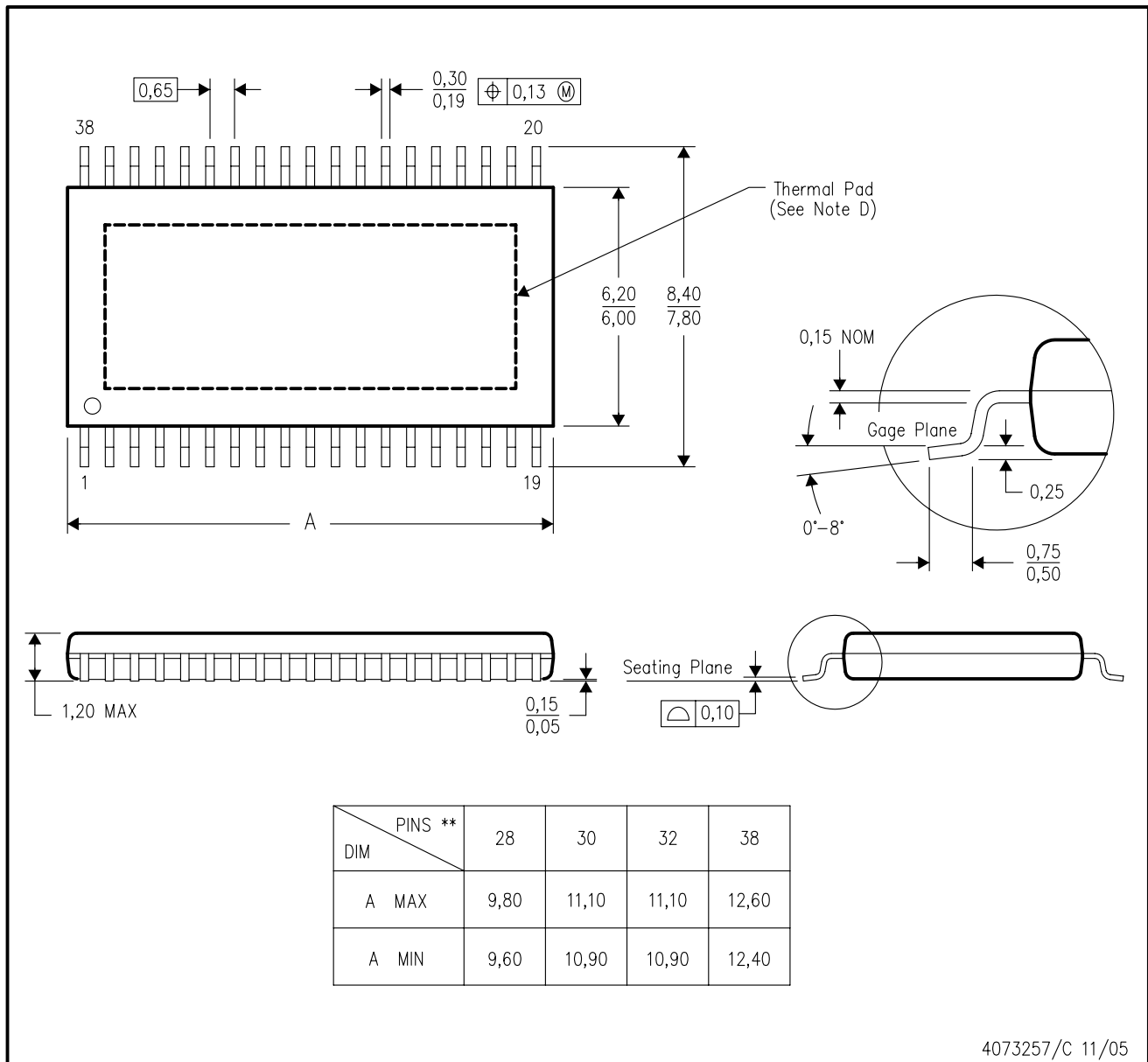

- NOTES:
- A. All linear dimensions are in millimeters.
 - B. This drawing is subject to change without notice.
 - C. Body dimensions do not include mold flash or protrusion. Mold flash and protrusion shall not exceed 0.15 per side.
 - D. This package is designed to be soldered to a thermal pad on the board. Refer to Technical Brief, PowerPad Thermally Enhanced Package, Texas Instruments Literature No. SLMA002 for information regarding recommended board layout. This document is available at www.ti.com <<http://www.ti.com>>.
 - E. Falls within JEDEC MO-153

PowerPAD is a trademark of Texas Instruments.

IMPORTANT NOTICE

Texas Instruments Incorporated and its subsidiaries (TI) reserve the right to make corrections, modifications, enhancements, improvements, and other changes to its products and services at any time and to discontinue any product or service without notice. Customers should obtain the latest relevant information before placing orders and should verify that such information is current and complete. All products are sold subject to TI's terms and conditions of sale supplied at the time of order acknowledgment.

TI warrants performance of its hardware products to the specifications applicable at the time of sale in accordance with TI's standard warranty. Testing and other quality control techniques are used to the extent TI deems necessary to support this warranty. Except where mandated by government requirements, testing of all parameters of each product is not necessarily performed.

TI assumes no liability for applications assistance or customer product design. Customers are responsible for their products and applications using TI components. To minimize the risks associated with customer products and applications, customers should provide adequate design and operating safeguards.

TI does not warrant or represent that any license, either express or implied, is granted under any TI patent right, copyright, mask work right, or other TI intellectual property right relating to any combination, machine, or process in which TI products or services are used. Information published by TI regarding third-party products or services does not constitute a license from TI to use such products or services or a warranty or endorsement thereof. Use of such information may require a license from a third party under the patents or other intellectual property of the third party, or a license from TI under the patents or other intellectual property of TI.

Reproduction of information in TI data books or data sheets is permissible only if reproduction is without alteration and is accompanied by all associated warranties, conditions, limitations, and notices. Reproduction of this information with alteration is an unfair and deceptive business practice. TI is not responsible or liable for such altered documentation.

Resale of TI products or services with statements different from or beyond the parameters stated by TI for that product or service voids all express and any implied warranties for the associated TI product or service and is an unfair and deceptive business practice. TI is not responsible or liable for any such statements.

Following are URLs where you can obtain information on other Texas Instruments products and application solutions:

Products		Applications	
Amplifiers	amplifier.ti.com	Audio	www.ti.com/audio
Data Converters	dataconverter.ti.com	Automotive	www.ti.com/automotive
DSP	dsp.ti.com	Broadband	www.ti.com/broadband
Interface	interface.ti.com	Digital Control	www.ti.com/digitalcontrol
Logic	logic.ti.com	Military	www.ti.com/military
Power Mgmt	power.ti.com	Optical Networking	www.ti.com/opticalnetwork
Microcontrollers	microcontroller.ti.com	Security	www.ti.com/security
Low Power Wireless	www.ti.com/lpw	Telephony	www.ti.com/telephony
		Video & Imaging	www.ti.com/video
		Wireless	www.ti.com/wireless

Mailing Address: Texas Instruments
Post Office Box 655303 Dallas, Texas 75265