

TLC5602C, TLC5602M VIDEO 8-BIT DIGITAL-TO-ANALOG CONVERTERS

SLAS023D – FEBRUARY 1989 – REVISED JANUARY 2002

- 8-Bit Resolution
- $\pm 0.2\%$ Linearity
- Maximum Conversion Rate
30 MHz Typ
20 MHz Min
- Analog Output Voltage Range
 V_{DD} to $V_{DD} - 1$ V
- TTL Digital Input Voltage
- 5-V Single Power-Supply Operation
- Low Power Consumption . . . 80 mW Typ
- Interchangeable With Fujitsu MB40778

description

The TLC5602x devices are low-power, ultra-high-speed video, digital-to-analog converters that use the LinEPIC™ 1- μ m CMOS process. The TLC5602x converts digital signals to analog signals at a sampling rate of dc to 20 MHz. Because of high-speed operation, the TLC5602x devices are suitable for digital video applications such as digital television, video processing with a computer, and radar-signal processing.

The TLC5602C is characterized for operation from 0°C to 70°C. The TLC5602M is characterized over the full military temperature range of -55°C to 125°C.

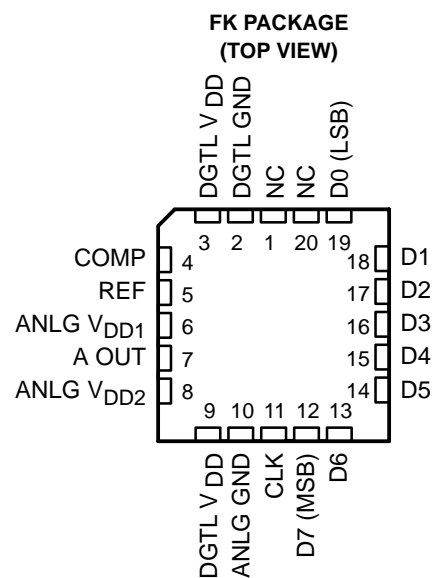
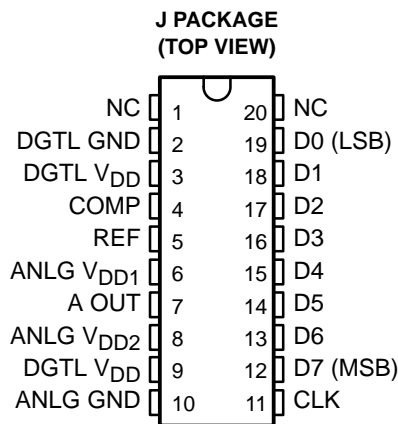
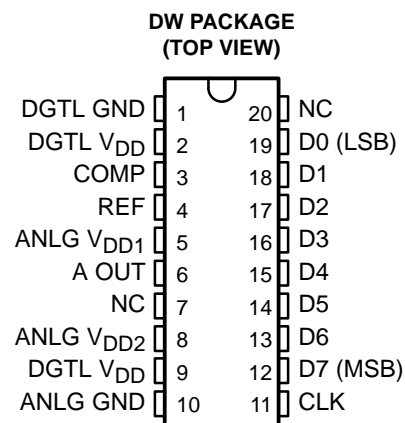
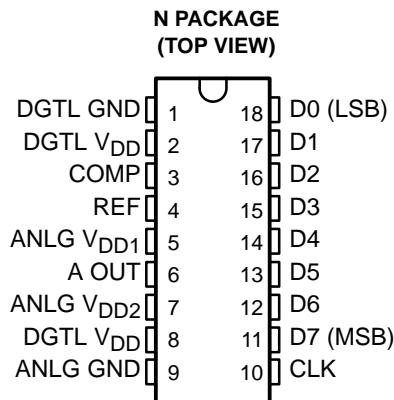

NC—No internal connection

LinEPIC is a trademark of Texas Instruments Incorporated.

PRODUCTION DATA information is current as of publication date. Products conform to specifications per the terms of Texas Instruments standard warranty. Production processing does not necessarily include testing of all parameters.



POST OFFICE BOX 655303 • DALLAS, TEXAS 75265

Copyright © 2002, Texas Instruments Incorporated

TLC5602C, TLC5602M VIDEO 8-BIT DIGITAL-TO-ANALOG CONVERTERS

SLAS023D – FEBRUARY 1989 – REVISED JANUARY 2002

AVAILABLE OPTIONS

PACKAGE				
T _A	WIDE-BODY SMALL OUTLINE (DW)	CERAMIC CHIP CARRIER (FK)	CERAMIC DIP (J)	PLASTIC DIP (N)
0°C to 70°C	TLC5602CDW			TLC5602CN
-55°C to 125°C		TLC5602MFK	TLC5602MJ	

functional block diagram

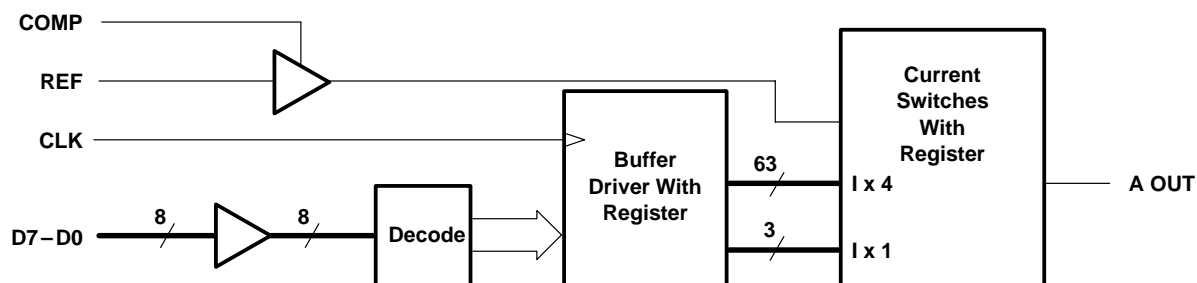

FUNCTION TABLE

STEP	DIGITAL INPUTS								OUTPUT VOLTAGE†
	D7	D6	D5	D4	D3	D2	D1	D0	
0	L	L	L	L	L	L	L	L	3.980 V
1	L	L	L	L	L	L	L	H	3.984 V
127	L	H	H	H	H	H	H	H	4.488 V
128	H	L	L	L	L	L	L	L	4.492 V
129	H	L	L	L	L	L	L	H	4.496 V
254	H	H	H	H	H	H	H	L	4.996 V
255	H	H	H	H	H	H	H	H	5.000 V

† V_{DD} = 5 V and V_{ref} = 4.02 V



POST OFFICE BOX 655303 • DALLAS, TEXAS 75265

schematics of equivalent input and output

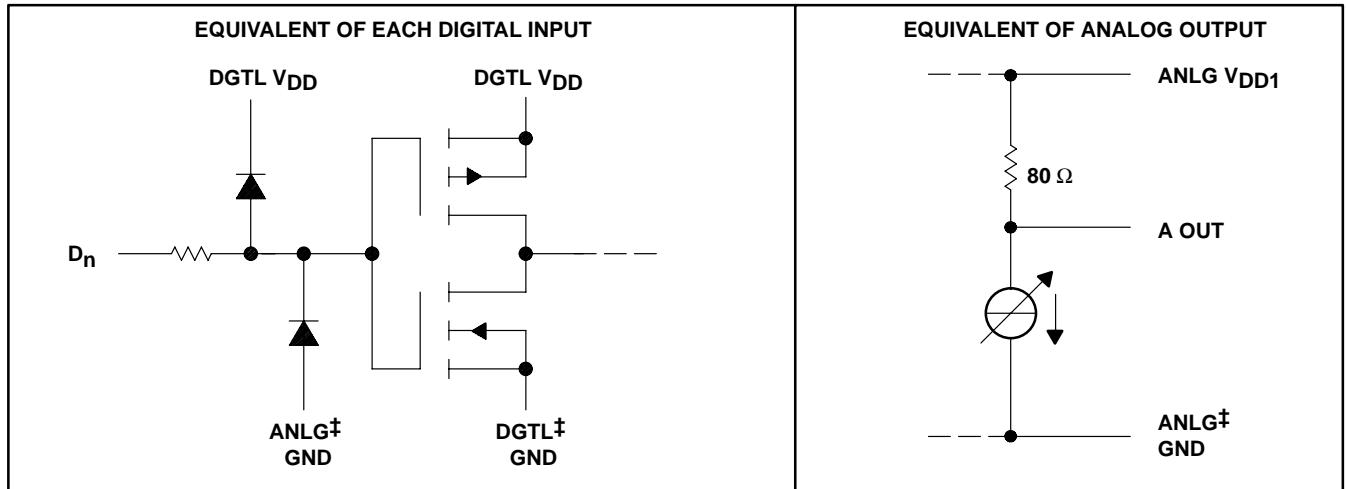

† ANLG GND and DGTL GND do not connect internally and should be tied together as close to the device terminals as possible.

absolute maximum ratings over operating free-air temperature range (unless otherwise noted)†

Supply voltage range, ANLG V_{DD} , DGTL V_{DD}	-0.5 V to 7 V
Digital input voltage range, V_I	-0.5 V to 7 V
Analog reference voltage range, V_{ref}	$V_{DD} - 1.7$ V to $V_{DD} + 0.5$ V
Operating free-air temperature range, T_A : TLC5602C	0°C to 70°C
TLC5602M	-55°C to 125°C
Storage temperature range, T_{stg}	-65°C to 150°C
Lead temperature 1,6 mm (1/16 inch) from case for 10 seconds	260°C

† Stresses beyond those listed under “absolute maximum ratings” may cause permanent damage to the device. These are stress ratings only, and functional operation of the device at these or any other conditions beyond those indicated under “recommended operating conditions” is not implied. Exposure to absolute-maximum-rated conditions for extended periods may affect device reliability.

recommended operating conditions

	MIN	NOM	MAX	UNIT
Supply voltage, V_{DD}	4.75	5	5.25	V
Analog reference voltage, V_{ref}	3.8	4	4.2	V
High-level input voltage, V_{IH}	2			V
Low-level input voltage, V_{IL}			0.8	V
Pulse duration, CLK high or low, t_w	25			ns
Setup time, data before CLK↑, t_{su}	16.5			ns
Hold time, data after CLK↑, t_h	12.5			ns
Phase compensation capacitance, C_{comp} (see Note 1)	1			μF
Load resistance, R_L	75			Ω
Operating free-air temperature, T_A	TLC5602C	0	70	°C
	TLC5602M	-55	125	

NOTE 1: The phase compensation capacitor should be connected between COMP and ANLG GND.

TLC5602C, TLC5602M VIDEO 8-BIT DIGITAL-TO-ANALOG CONVERTERS

SLAS023D – FEBRUARY 1989 – REVISED JANUARY 2002

electrical characteristics over recommended ranges of supply voltage and operating free-air temperature (unless otherwise noted)

PARAMETER		TEST CONDITIONS	MIN	TYP [‡]	MAX	UNIT	
I _{IH}	High-level input current	Digital inputs V _I = 5 V			±1	μA	
I _{IL}	Low-level input current	V _I = 0 V			±1	μA	
I _{ref}	Input reference current	V _{ref} = 4 V			10	μA	
V _{FS}	Full-scale analog output voltage	V _{DD} = 5 V, V _{ref} = 4.02 V	V _{DD} - 15	V _{DD}	V _{DD} + 15	mV	
V _{ZS}	Zero-scale analog output voltage	V _{DD} = 5 V, V _{ref} = 4.02 V, T _A = full range [§]	TLC5602C	3.919	3.98	4.042	V
			TLC5602M	3.919	3.98	4.042	
			TLC5602M	3.919	3.98	4.062	
r _o	Output resistance	T _A = 25°C	60	80	120	Ω	
		T _A = full range [§]					
C _i	Input capacitance	f _{clock} = 1 MHz, T _A = 25°C		15		pF	
I _{DD}	Supply current	f _{clock} = 20 MHz, V _{ref} = V _{DD} - 0.95 V		16	25	mA	

[‡] All typical values are at V_{DD} = 5 V and T_A = 25°C.

[§] Full range for the TLC5602C is 0°C to 70°C, and full range for the TLC5602M is -55°C to 125°C.

operating characteristics over recommended ranges of supply voltage and operating free-air temperature (unless otherwise noted)

PARAMETER		TEST CONDITIONS	MIN	TYP [†]	MAX	UNIT
E _{L(adj)}	Linearity error, best-straight-line	T _A = full range [‡]	TLC5602C	±0.2%		
		T _A = 25°C		±0.2%		
		T _A = full range [‡]		±0.4%		
E _L	Linearity error, end point			±0.15%		
E _D	Linearity error, differential			±0.2%		
G _{diff}	Differential gain	NTSC 40-IRE modulated ramp, f _{clock} = 14.3 MHz, Z _L ≥ 75 kΩ		0.7%		
f _{diff}	Differential phase			0.4°		
t _{pd}	Propagation delay time, CLK to analog output	C _L = 10 pF		25		ns
t _s	Settling time to within 1/2 LSB	C _L = 10 pF		30		ns

[†] All typical values are at V_{DD} = 5 V and T_A = 25°C.

[‡] Full range for the TLC5602C is 0°C to 70°C, and full range for the TLC5602M is -55°C to 125°C.



PARAMETER MEASUREMENT INFORMATION

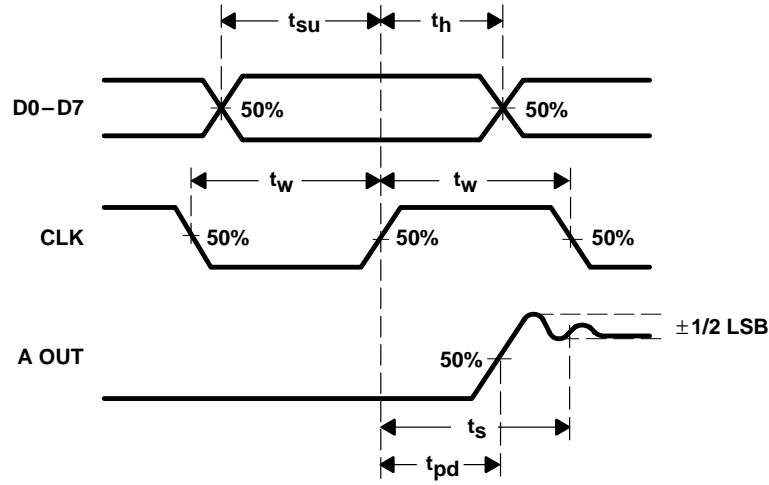

Figure 1. Voltage Waveforms

TLC5602C, TLC5602M VIDEO 8-BIT DIGITAL-TO-ANALOG CONVERTERS

SLAS023D – FEBRUARY 1989 – REVISED JANUARY 2002

TYPICAL CHARACTERISTICS

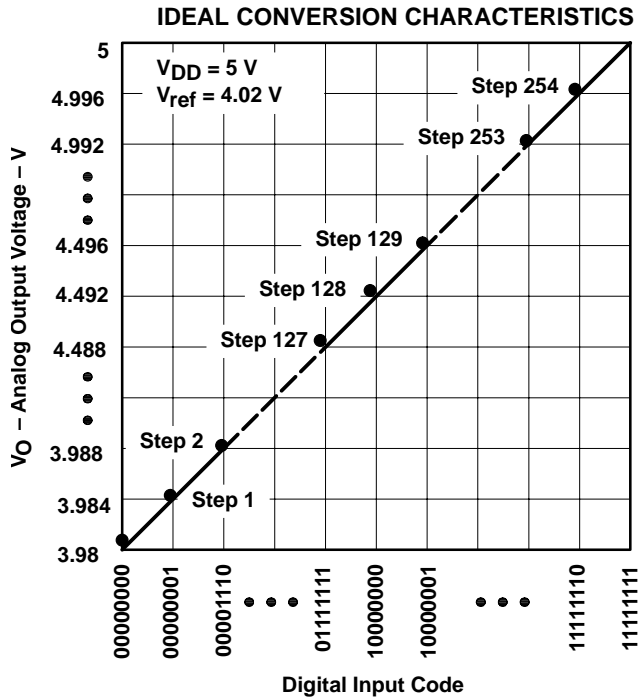

Figure 2

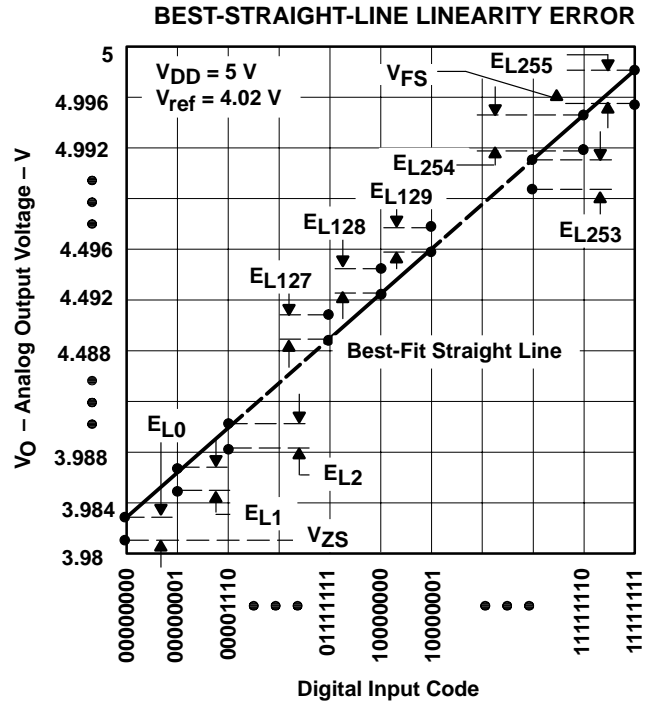

Figure 3

ZERO-SCALE OUTPUT VOLTAGE vs FREE-AIR TEMPERATURE

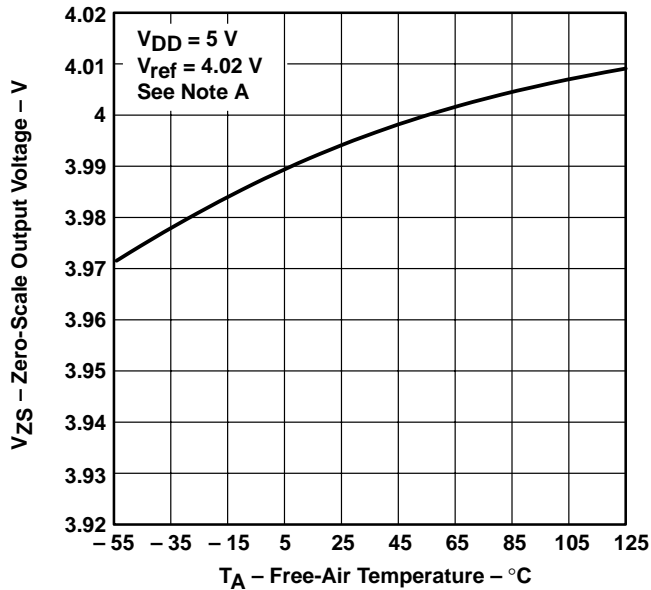

Figure 4

OUTPUT RESISTANCE vs FREE-AIR TEMPERATURE

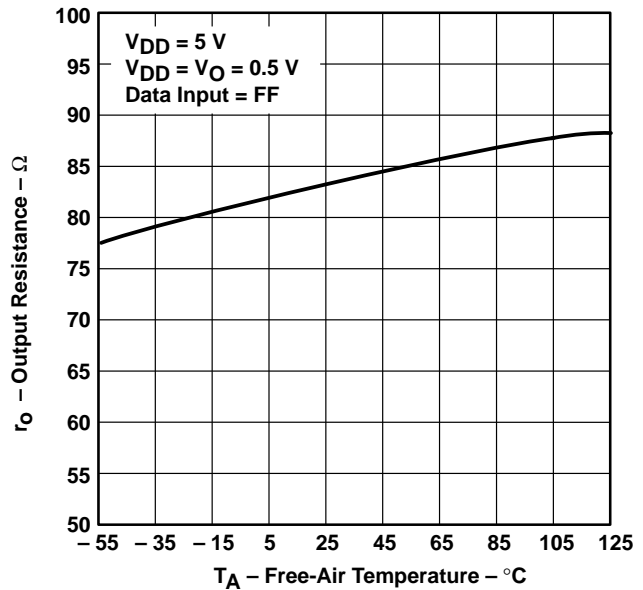

Figure 5

NOTE A: V_{ref} is relative to ANLG GND. V_{DD} is the voltage between ANLG V_{DD} and DGTL V_{DD} tied together and ANLG GND and DGTL GND tied together.



POST OFFICE BOX 655303 • DALLAS, TEXAS 75265

TYPICAL CHARACTERISTICS

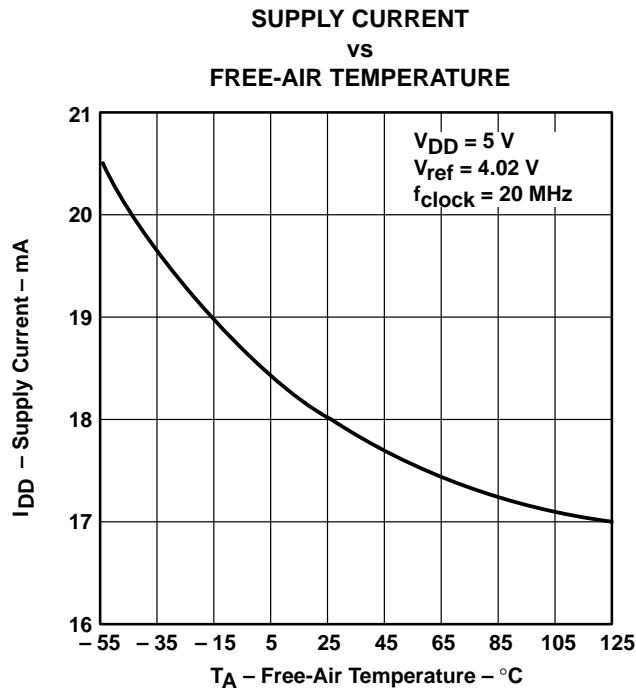
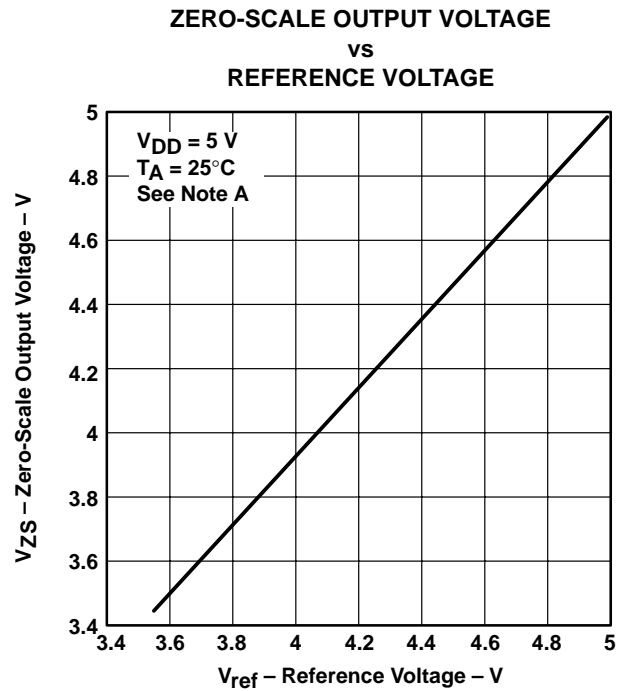

Figure 6



NOTE A: V_{ref} is relative to ANLG GND. V_{DD} is the voltage between ANLG V_{DD} and DGTL V_{DD} tied together and ANLG GND and DGTL GND tied together.

Figure 7

TLC5602C, TLC5602M

VIDEO 8-BIT DIGITAL-TO-ANALOG CONVERTERS

SLAS023D – FEBRUARY 1989 – REVISED JANUARY 2002

APPLICATION INFORMATION

The following design recommendations benefit the TLC5602 user:

- Physically separate and shield external analog and digital circuitry as much as possible to reduce system noise.
- Use RF breadboarding or RF printed-circuit-board (PCB) techniques throughout the evaluation and production process.
- Since ANLG GND and DGTL GND are not connected internally, these terminals need to be connected externally. With breadboards, these ground lines should connect to the power-supply ground through separate leads with proper supply bypassing. A good method is to use a separate twisted pair for the analog and digital supply lines to minimize noise pickup.

Use wide ground leads or a ground plane on the PCB layouts to minimize parasitic inductance and resistance. The ground plane is the better choice for noise reduction.

- ANLG V_{DD} and DGTL V_{DD} are also separated internally, so they must connect externally. These external PCB leads should also be made as wide as possible. Place a ferrite bead or equivalent inductance in series with ANLG V_{DD} and the decoupling capacitor as close to the device terminals as possible before the ANLG V_{DD} and DGTL V_{DD} leads are connected together on the board.
- Decouple ANLG V_{DD} to ANLG GND and DGTL V_{DD} to DGTL GND with a 1- μ F and 0.01- μ F capacitor, respectively, as close as possible to the appropriate device terminals. A ceramic chip capacitor is recommended for the 0.01- μ F capacitor.
- Connect the phase compensation capacitor between COMP and ANLG GND with as short a lead-in as possible.
- The no-connection (NC) terminals on the small-outline package should be connected to ANLG GND.
- Shield ANLG V_{DD} , ANLG GND, and A OUT from the high-frequency terminals CLK and D7–D0. Place ANLG GND traces on both sides of the A OUT trace on the PCB.



POST OFFICE BOX 655303 • DALLAS, TEXAS 75265

PACKAGING INFORMATION

Orderable Device	Status ⁽¹⁾	Package Type	Package Drawing	Pins	Package Qty	Eco Plan ⁽²⁾	Lead/Ball Finish	MSL Peak Temp ⁽³⁾
TLC5602CDW	ACTIVE	SOIC	DW	20	25	Green (RoHS & no Sb/Br)	CU NIPDAU	Level-1-260C-UNLIM
TLC5602CDWG4	ACTIVE	SOIC	DW	20	25	Green (RoHS & no Sb/Br)	CU NIPDAU	Level-1-260C-UNLIM
TLC5602CDWR	ACTIVE	SOIC	DW	20	2000	Green (RoHS & no Sb/Br)	CU NIPDAU	Level-1-260C-UNLIM
TLC5602CDWRG4	ACTIVE	SOIC	DW	20	2000	Green (RoHS & no Sb/Br)	CU NIPDAU	Level-1-260C-UNLIM
TLC5602CN	OBSOLETE	PDIP	N	18		TBD	Call TI	Call TI
TLC5602MJB	OBSOLETE	CDIP	J	20		TBD	Call TI	Call TI

⁽¹⁾ The marketing status values are defined as follows:

ACTIVE: Product device recommended for new designs.

LIFEBUY: TI has announced that the device will be discontinued, and a lifetime-buy period is in effect.

NRND: Not recommended for new designs. Device is in production to support existing customers, but TI does not recommend using this part in a new design.

PREVIEW: Device has been announced but is not in production. Samples may or may not be available.

OBSOLETE: TI has discontinued the production of the device.

⁽²⁾ Eco Plan - The planned eco-friendly classification: Pb-Free (RoHS), Pb-Free (RoHS Exempt), or Green (RoHS & no Sb/Br) - please check <http://www.ti.com/productcontent> for the latest availability information and additional product content details.

TBD: The Pb-Free/Green conversion plan has not been defined.

Pb-Free (RoHS): TI's terms "Lead-Free" or "Pb-Free" mean semiconductor products that are compatible with the current RoHS requirements for all 6 substances, including the requirement that lead not exceed 0.1% by weight in homogeneous materials. Where designed to be soldered at high temperatures, TI Pb-Free products are suitable for use in specified lead-free processes.

Pb-Free (RoHS Exempt): This component has a RoHS exemption for either 1) lead-based flip-chip solder bumps used between the die and package, or 2) lead-based die adhesive used between the die and leadframe. The component is otherwise considered Pb-Free (RoHS compatible) as defined above.

Green (RoHS & no Sb/Br): TI defines "Green" to mean Pb-Free (RoHS compatible), and free of Bromine (Br) and Antimony (Sb) based flame retardants (Br or Sb do not exceed 0.1% by weight in homogeneous material)

⁽³⁾ MSL, Peak Temp. -- The Moisture Sensitivity Level rating according to the JEDEC industry standard classifications, and peak solder temperature.

Important Information and Disclaimer:The information provided on this page represents TI's knowledge and belief as of the date that it is provided. TI bases its knowledge and belief on information provided by third parties, and makes no representation or warranty as to the accuracy of such information. Efforts are underway to better integrate information from third parties. TI has taken and continues to take reasonable steps to provide representative and accurate information but may not have conducted destructive testing or chemical analysis on incoming materials and chemicals. TI and TI suppliers consider certain information to be proprietary, and thus CAS numbers and other limited information may not be available for release.

In no event shall TI's liability arising out of such information exceed the total purchase price of the TI part(s) at issue in this document sold by TI to Customer on an annual basis.

J (R-GDIP-T**)
14 LEADS SHOWN

CERAMIC DUAL IN-LINE PACKAGE

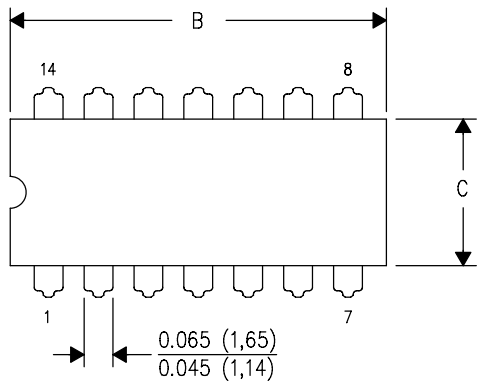

DIM \ PINS **	14	16	18	20
A	0.300 (7,62) BSC	0.300 (7,62) BSC	0.300 (7,62) BSC	0.300 (7,62) BSC
B MAX	0.785 (19,94)	.840 (21,34)	0.960 (24,38)	1.060 (26,92)
B MIN	—	—	—	—
C MAX	0.300 (7,62)	0.300 (7,62)	0.310 (7,87)	0.300 (7,62)
C MIN	0.245 (6,22)	0.245 (6,22)	0.220 (5,59)	0.245 (6,22)

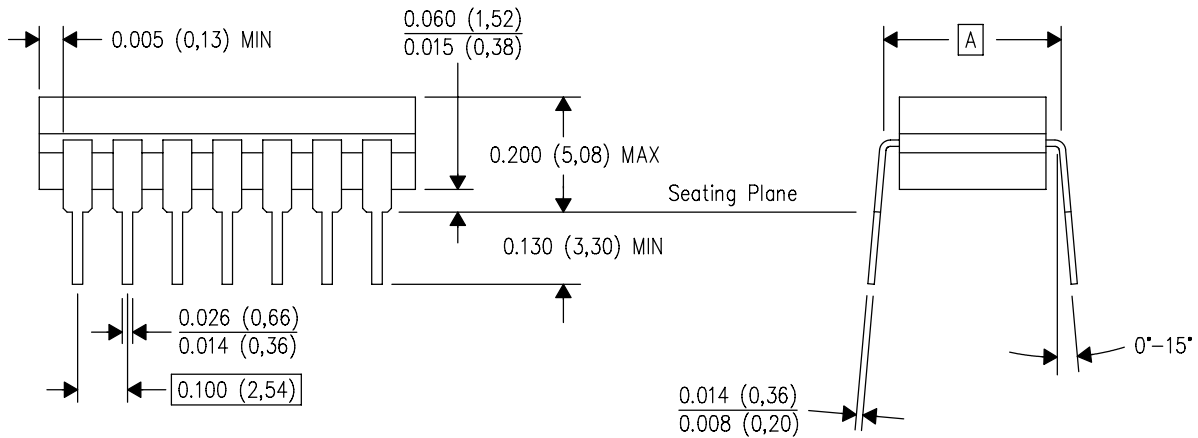

4040083/F 03/03

- NOTES:
- All linear dimensions are in inches (millimeters).
 - This drawing is subject to change without notice.
 - This package is hermetically sealed with a ceramic lid using glass frit.
 - Index point is provided on cap for terminal identification only on press ceramic glass frit seal only.
 - Falls within MIL STD 1835 GDIP1-T14, GDIP1-T16, GDIP1-T18 and GDIP1-T20.

DW (R-PDSO-G20)

PLASTIC SMALL-OUTLINE PACKAGE



- NOTES:
- A. All linear dimensions are in inches (millimeters).
 - B. This drawing is subject to change without notice.
 - C. Body dimensions do not include mold flash or protrusion not to exceed 0.006 (0,15).
 - D. Falls within JEDEC MS-013 variation AC.

IMPORTANT NOTICE

Texas Instruments Incorporated and its subsidiaries (TI) reserve the right to make corrections, modifications, enhancements, improvements, and other changes to its products and services at any time and to discontinue any product or service without notice. Customers should obtain the latest relevant information before placing orders and should verify that such information is current and complete. All products are sold subject to TI's terms and conditions of sale supplied at the time of order acknowledgment.

TI warrants performance of its hardware products to the specifications applicable at the time of sale in accordance with TI's standard warranty. Testing and other quality control techniques are used to the extent TI deems necessary to support this warranty. Except where mandated by government requirements, testing of all parameters of each product is not necessarily performed.

TI assumes no liability for applications assistance or customer product design. Customers are responsible for their products and applications using TI components. To minimize the risks associated with customer products and applications, customers should provide adequate design and operating safeguards.

TI does not warrant or represent that any license, either express or implied, is granted under any TI patent right, copyright, mask work right, or other TI intellectual property right relating to any combination, machine, or process in which TI products or services are used. Information published by TI regarding third-party products or services does not constitute a license from TI to use such products or services or a warranty or endorsement thereof. Use of such information may require a license from a third party under the patents or other intellectual property of the third party, or a license from TI under the patents or other intellectual property of TI.

Reproduction of information in TI data books or data sheets is permissible only if reproduction is without alteration and is accompanied by all associated warranties, conditions, limitations, and notices. Reproduction of this information with alteration is an unfair and deceptive business practice. TI is not responsible or liable for such altered documentation.

Resale of TI products or services with statements different from or beyond the parameters stated by TI for that product or service voids all express and any implied warranties for the associated TI product or service and is an unfair and deceptive business practice. TI is not responsible or liable for any such statements.

Following are URLs where you can obtain information on other Texas Instruments products and application solutions:

Products		Applications	
Amplifiers	amplifier.ti.com	Audio	www.ti.com/audio
Data Converters	dataconverter.ti.com	Automotive	www.ti.com/automotive
DSP	dsp.ti.com	Broadband	www.ti.com/broadband
Interface	interface.ti.com	Digital Control	www.ti.com/digitalcontrol
Logic	logic.ti.com	Military	www.ti.com/military
Power Mgmt	power.ti.com	Optical Networking	www.ti.com/opticalnetwork
Microcontrollers	microcontroller.ti.com	Security	www.ti.com/security
		Telephony	www.ti.com/telephony
		Video & Imaging	www.ti.com/video
		Wireless	www.ti.com/wireless

Mailing Address: Texas Instruments
Post Office Box 655303 Dallas, Texas 75265

Copyright © 2006, Texas Instruments Incorporated