

TLC2932 HIGH-PERFORMANCE PHASE-LOCKED LOOP

SLAS097E – SEPTEMBER 1994 – REVISED MAY 1997

- **Voltage-Controlled Oscillator (VCO) Section:**
 - Complete Oscillator Using Only One External Bias Resistor (R_{BIAS})
 - Lock Frequency:
 - 22 MHz to 50 MHz ($V_{DD} = 5\text{ V} \pm 5\%$, $T_A = -20^\circ\text{C}$ to 75°C , $\times 1$ Output)
 - 11 MHz to 25 MHz ($V_{DD} = 5\text{ V} \pm 5\%$, $T_A = -20^\circ\text{C}$ to 75°C , $\times 1/2$ Output)
 - Output Frequency . . . $\times 1$ and $\times 1/2$ Selectable
- **Phase-Frequency Detector (PFD) Section Includes a High-Speed Edge-Triggered Detector With Internal Charge Pump**
- **Independent VCO, PFD Power-Down Mode**
- **Thin Small-Outline Package (14 terminal)**
- **CMOS Technology**
- **Typical Applications:**
 - Frequency Synthesis
 - Modulation/Demodulation
 - Fractional Frequency Division
- **Application Report Available†**
- **CMOS Input Logic Level**

**PW PACKAGE†
(TOP VIEW)**

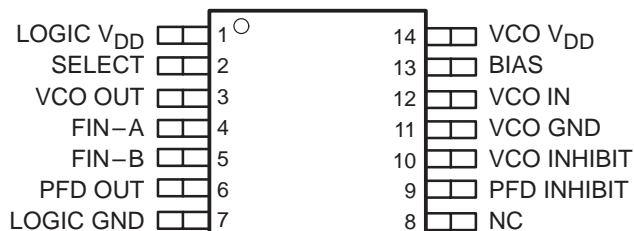

† Available in tape and reel only and ordered as the TLC2932IPWLE.
NC – No internal connection

description

The TLC2932 is designed for phase-locked-loop (PLL) systems and is composed of a voltage-controlled oscillator (VCO) and an edge-triggered-type phase frequency detector (PFD). The oscillation frequency range of the VCO is set by an external bias resistor (R_{BIAS}). The VCO has a 1/2 frequency divider at the output stage. The high-speed PFD with internal charge pump detects the phase difference between the reference frequency input and signal frequency input from the external counter. Both the VCO and the PFD have inhibit functions, which can be used as a power-down mode. The TLC2932 is suitable for use as a high-performance PLL due to the high speed and stable oscillation capability of the device.

functional block diagram

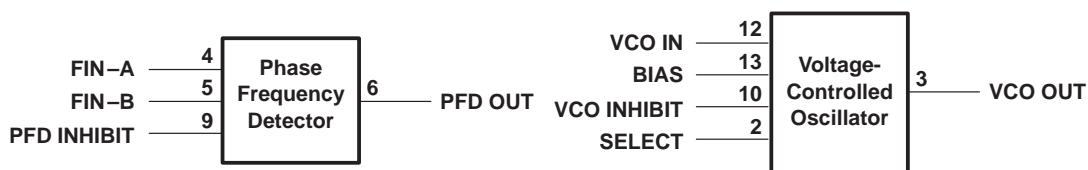

AVAILABLE OPTIONS

T_A	PACKAGE
	SMALL OUTLINE (PW)
-20°C to 75°C	TLC2932IPWLE



Please be aware that an important notice concerning availability, standard warranty, and use in critical applications of Texas Instruments semiconductor products and disclaimers thereto appears at the end of this data sheet.

† TLC2932 Phase-Locked-Loop Building Block With Analog Voltage-Controlled Oscillator and Phase Frequency Detector (SLAA011).

PRODUCTION DATA information is current as of publication date. Products conform to specifications per the terms of Texas Instruments standard warranty. Production processing does not necessarily include testing of all parameters.

**TEXAS
INSTRUMENTS**

POST OFFICE BOX 655303 • DALLAS, TEXAS 75265

Copyright © 1997, Texas Instruments Incorporated

TLC2932

HIGH-PERFORMANCE PHASE-LOCKED LOOP

SLAS097E – SEPTEMBER 1994 – REVISED MAY 1997

Terminal Functions

TERMINAL NAME	NO.	I/O	DESCRIPTION
FIN–A	4	I	Input reference frequency $f_{(REF\ IN)}$ is applied to FIN–A.
FIN–B	5	I	Input for VCO external counter output frequency $f_{(FIN-B)}$. FIN–B is nominally provided from the external counter.
LOGIC GND	7		GND for the internal logic.
LOGIC V_{DD}	1		Power supply for the internal logic. This power supply should be separate from VCO V_{DD} to reduce cross-coupling between supplies.
NC	8		No internal connection.
PFD INHIBIT	9	I	PFD inhibit control. When PFD INHIBIT is high, PFD output is in the high-impedance state, see Table 3.
PFD OUT	6	O	PFD output. When the PFD INHIBIT is high, PFD output is in the high-impedance state.
BIAS	13	I	Bias supply. An external resistor (R_{BIAS}) between VCO V_{DD} and BIAS supplies bias for adjusting the oscillation frequency range.
SELECT	2	I	VCO output frequency select. When SELECT is high, the VCO output frequency is $\times 1/2$ and when low, the output frequency is $\times 1$, see Table 1.
VCO IN	12	I	VCO control voltage input. Nominally the external loop filter output connects to VCO IN to control VCO oscillation frequency.
VCO INHIBIT	10	I	VCO inhibit control. When VCO INHIBIT is high, VCO OUT is low (see Table 2).
VCO GND	11		GND for VCO.
VCO OUT	3	O	VCO output. When the VCO INHIBIT is high, VCO output is low.
VCO V_{DD}	14		Power supply for VCO. This power supply should be separated from LOGIC V_{DD} to reduce cross-coupling between supplies.

detailed description

VCO oscillation frequency

The VCO oscillation frequency is determined by an external resistor (R_{BIAS}) connected between the VCO V_{DD} and the BIAS terminals. The oscillation frequency and range depends on this resistor value. The bias resistor value for the minimum temperature coefficient is nominally 3.3 k Ω with 3-V at the VCO V_{DD} terminal and nominally 2.2 k Ω with 5-V at the VCO V_{DD} terminal. For the lock frequency range refer to the recommended operating conditions. Figure 1 shows the typical frequency variation and VCO control voltage.

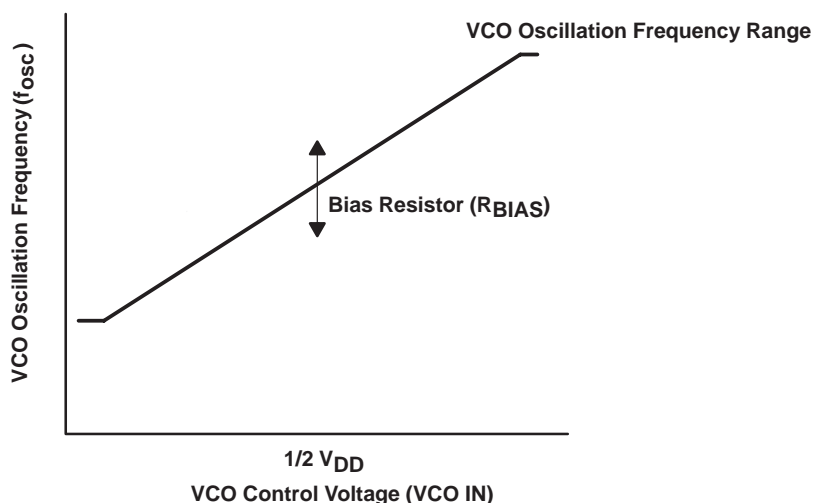

Figure 1. VCO Oscillation Frequency

VCO output frequency 1/2 divider

The TLC2932 SELECT terminal sets the f_{osc} or $1/2 f_{osc}$ VCO output frequency as shown in Table 1. The $1/2 f_{osc}$ output should be used for minimum VCO output jitter.

Table 1. VCO Output 1/2 Divider Function

SELECT	VCO OUTPUT
Low	f_{osc}
High	$1/2 f_{osc}$

VCO inhibit function

The VCO has an externally controlled inhibit function which inhibits the VCO output. A high level on the VCO INHIBIT terminal stops the VCO oscillation and powers down the VCO. The output maintains a low level during the power-down mode, refer to Table 2.

Table 2. VCO Inhibit Function

VCO INHIBIT	VCO OSCILLATOR	VCO OUTPUT	$I_{DD}(VCO)$
Low	Active	Active	Normal
High	Stopped	Low level	Power Down

PFD operation

The PFD is a high-speed, edge-triggered detector with an internal charge pump. The PFD detects the phase difference between two frequency inputs supplied to FIN-A and FIN-B as shown in Figure 2. Nominally the reference is supplied to FIN-A, and the frequency from the external counter output is fed to FIN-B.

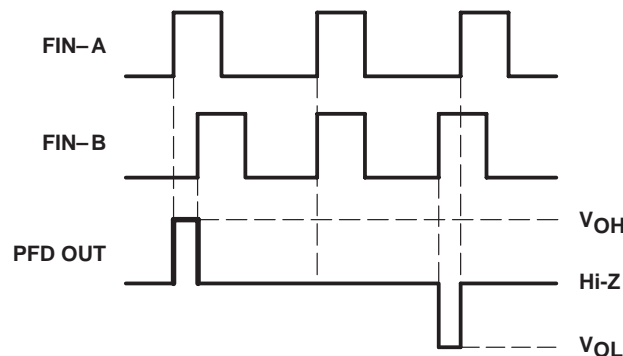

Figure 2. PFD Function Timing Chart

PFD output control

A high level on the PFD INHIBIT terminal places the PFD output in the high-impedance state and the PFD stops phase detection as shown in Table 3. A high level on the PFD INHIBIT terminal also can be used as the power-down mode for the PFD.

Table 3. VCO Output Control Function

PFD INHIBIT	DETECTION	PFD OUTPUT	$I_{DD}(PFD)$
Low	Active	Active	Normal
High	Stopped	Hi-Z	Power Down

TLC2932 HIGH-PERFORMANCE PHASE-LOCKED LOOP

SLAS097E – SEPTEMBER 1994 – REVISED MAY 1997

schematics

VCO block schematic

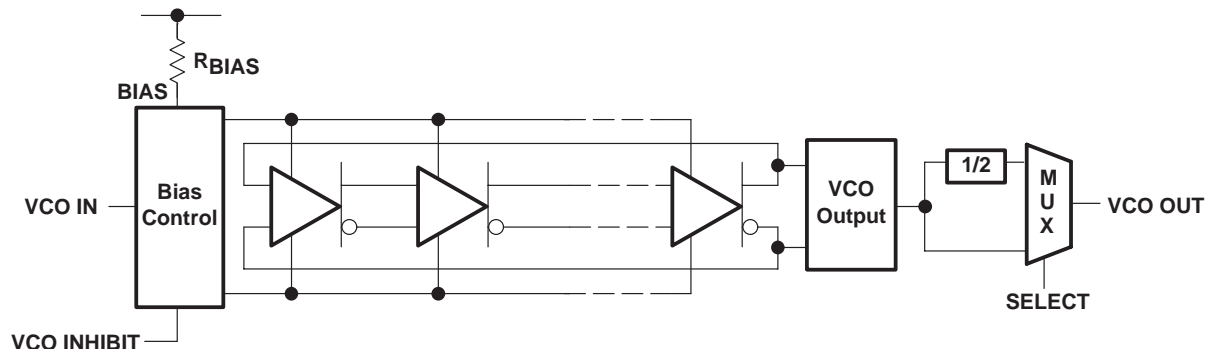

PFD block schematic

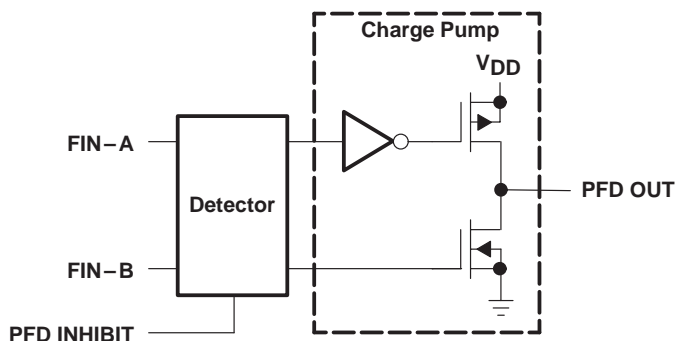

absolute maximum ratings†

Supply voltage (each supply), V _{DD} (see Note 1)	7 V
Input voltage range (each input), V _I (see Note 1)	-0.5 V to V _{DD} + 0.5 V
Input current (each input), I _I	±20 mA
Output current (each output), I _O	±20 mA
Continuous total power dissipation, at (or below) T _A = 25°C (see Note 2)	700 mW
Operating free-air temperature range, T _A	-20°C to 75°C
Storage temperature range, T _{stg}	-65°C to 150°C
Lead temperature 1,6 mm (1/16 inch) from case for 10 seconds	260°C

† Stresses beyond those listed under "absolute maximum ratings" may cause permanent damage to the device. These are stress ratings only, and functional operation of the device at these or any other conditions beyond those indicated under "recommended operating conditions" is not implied. Exposure to absolute-maximum-rated conditions for extended periods may affect device reliability.

- NOTES: 1. All voltage values are with respect to network GND.
2. For operation above 25°C free-air temperature, derate linearly at the rate of 5.6 mW/°C.

recommended operating conditions

PARAMETER		MIN	NOM	MAX	UNIT
Supply voltage, V_{DD} (each supply, see Note 3)	$V_{DD} = 3\text{ V}$	2.85	3	3.15	V
	$V_{DD} = 5\text{ V}$	4.75	5	5.25	
Input voltage, V_I (inputs except VCO IN)		0		V_{DD}	V
Output current, I_O (each output)		0		± 2	mA
VCO control voltage at VCO IN		0.9		V_{DD}	V
Lock frequency ($\times 1$ output)	$V_{DD} = 3\text{ V}$	14		21	MHz
	$V_{DD} = 5\text{ V}$	22		50	
Lock frequency ($\times 1/2$ output)	$V_{DD} = 3\text{ V}$	7		10.5	MHz
	$V_{DD} = 5\text{ V}$	11		25	
Bias resistor, R_{BIAS}	$V_{DD} = 3\text{ V}$	2.2	3.3	4.3	k Ω
	$V_{DD} = 5\text{ V}$	1.5	2.2	3.3	

NOTE 3: It is recommended that the logic supply terminal (LOGIC V_{DD}) and the VCO supply terminal (VCO V_{DD}) should be at the same voltage and separated from each other.

electrical characteristics over recommended operating free-air temperature range, $V_{DD} = 3\text{ V}$ (unless otherwise noted)

VCO section

PARAMETER		TEST CONDITIONS	MIN	TYP	MAX	UNIT
V_{OH}	High-level output voltage	$I_{OH} = -2\text{ mA}$	2.4			V
V_{OL}	Low-level output voltage	$I_{OL} = 2\text{ mA}$			0.3	V
V_{IT}	Input threshold voltage at SELECT, VCO INHIBIT		0.9	1.5	2.1	V
I_I	Input current at SELECT, VCO INHIBIT	$V_I = V_{DD}$ or GND			± 1	μA
$Z_i(\text{VCO IN})$	Input impedance	$V_{CO IN} = 1/2 V_{DD}$		10		M Ω
$I_{DD}(\text{INH})$	VCO supply current (inhibit)	See Note 4		0.01	1	μA
$I_{DD}(\text{VCO})$	VCO supply current	See Note 5		5	15	mA

NOTES: 4. Current into VCO V_{DD} , when VCO INHIBIT = V_{DD} , PFD is inhibited.
5. Current into VCO V_{DD} , when VCO IN = $1/2 V_{DD}$, $R_{BIAS} = 3.3\text{ k}\Omega$, VCO INHIBIT = GND, and PFD is inhibited.

PFD section

PARAMETER		TEST CONDITIONS	MIN	TYP	MAX	UNIT
V_{OH}	High-level output voltage	$I_{OH} = -2\text{ mA}$	2.7			V
V_{OL}	Low-level output voltage	$I_{OL} = 2\text{ mA}$			0.2	V
I_{OZ}	High-impedance-state output current	PFD INHIBIT = high, $V_I = V_{DD}$ or GND			± 1	μA
V_{IH}	High-level input voltage at FIN-A, FIN-B		2.7			V
V_{IL}	Low-level input voltage at FIN-A, FIN-B				0.5	V
V_{IT}	Input threshold voltage at PFD INHIBIT		0.9	1.5	2.1	V
C_i	Input capacitance at FIN-A, FIN-B			5		pF
Z_i	Input impedance at FIN-A, FIN-B			10		M Ω
$I_{DD}(Z)$	High-impedance-state PFD supply current	See Note 6		0.01	1	μA
$I_{DD}(\text{PFD})$	PFD supply current	See Note 7		0.1	1.5	mA

NOTES: 6. Current into LOGIC V_{DD} , when FIN-A, FIN-B = GND, PFD INHIBIT = V_{DD} , no load, and VCO OUT is inhibited.
7. Current into LOGIC V_{DD} , when FIN-A, FIN-B = 1 MHz ($V_{I(PP)} = 3\text{ V}$, rectangular wave), NC = GND, no load, and VCO OUT is inhibited.

TLC2932

HIGH-PERFORMANCE PHASE-LOCKED LOOP

SLAS097E – SEPTEMBER 1994 – REVISED MAY 1997

operating characteristics over recommended operating free-air temperature range, $V_{DD} = 3\text{ V}$ (unless otherwise noted)

VCO section

PARAMETER		TEST CONDITIONS	MIN	TYP	MAX	UNIT
f_{osc}	Operating oscillation frequency	$R_{BIAS} = 3.3\text{ k}\Omega$, VCO IN = $1/2 V_{DD}$	15	19	23	MHz
$t_s(f_{osc})$	Time to stable oscillation (see Note 8)	Measured from VCO INHIBIT↓			10	μs
t_r	Rise time	$C_L = 15\text{ pF}$, See Figure 3		7	14	ns
		$C_L = 50\text{ pF}$, See Figure 3		14		
t_f	Fall time	$C_L = 15\text{ pF}$, See Figure 3		6	12	ns
		$C_L = 50\text{ pF}$, See Figure 3		10		
Duty cycle at VCO OUT		$R_{BIAS} = 3.3\text{ k}\Omega$, VCO IN = $1/2 V_{DD}$.	45%	50%	55%	
$\alpha(f_{osc})$	Temperature coefficient of oscillation frequency	$R_{BIAS} = 3.3\text{ k}\Omega$, VCO IN = $1/2 V_{DD}$, $T_A = -20^\circ\text{C}$ to 75°C		0.04		$\%/^\circ\text{C}$
$k_{SVS}(f_{osc})$	Supply voltage coefficient of oscillation frequency	$R_{BIAS} = 3.3\text{ k}\Omega$, VCO IN = 1.5 V, $V_{DD} = 2.85\text{ V}$ to 3.15 V		0.02		$\%/mV$
Jitter absolute (see Note 9)		$R_{BIAS} = 3.3\text{ k}\Omega$		100		ps

- NOTES: 8. The time period to the stable VCO oscillation frequency after the VCO INHIBIT terminal is changed to a low level.
 9. The low-pass-filter (LPF) circuit is shown in Figure 28 with calculated values listed in Table 7. Jitter performance is highly dependent on circuit layout and external device characteristics. The jitter specification was made with a carefully designed PCB with no device socket.

PFD section

PARAMETER		TEST CONDITIONS	MIN	TYP	MAX	UNIT
f_{max}	Maximum operating frequency		20			MHz
t_{PLZ}	PFD output disable time from low level	See Figures 4 and 5 and Table 4		21	50	ns
t_{PHZ}	PFD output disable time from high level			23	50	
t_{PZL}	PFD output enable time to low level			11	30	ns
t_{PZH}	PFD output enable time to high level			10	30	
t_r	Rise time	$C_L = 15\text{ pF}$, See Figure 4		2.3	10	ns
t_f	Fall time			2.1	10	ns



TLC2932 HIGH-PERFORMANCE PHASE-LOCKED LOOP

SLAS097E – SEPTEMBER 1994 – REVISED MAY 1997

electrical characteristics over recommended operating free-air temperature range, $V_{DD} = 5\text{ V}$ (unless otherwise noted)

VCO section

PARAMETER		TEST CONDITIONS	MIN	TYP	MAX	UNIT
V_{OH}	High-level output voltage	$I_{OH} = -2\text{ mA}$	4			V
V_{OL}	Low-level output voltage	$I_{OL} = 2\text{ mA}$			0.5	V
V_{IT}	Input threshold voltage at SELECT, VCO INHIBIT		1.5	2.5	3.5	V
I_I	Input current at SELECT, VCO INHIBIT	$V_I = V_{DD}$ or GND			± 1	μA
$Z_i(\text{VCO IN})$	Input impedance	$\text{VCO IN} = 1/2 V_{DD}$		10		$\text{M}\Omega$
$I_{DD}(\text{INH})$	VCO supply current (inhibit)	See Note 4		0.01	1	μA
$I_{DD}(\text{VCO})$	VCO supply current	See Note 5		15	35	mA

NOTES: 4. Current into VCO V_{DD} , when VCO INHIBIT = V_{DD} , and PFD is inhibited.

5. Current into VCO V_{DD} , when VCO IN = $1/2 V_{DD}$, $R_{BIAS} = 3.3\text{ k}\Omega$, VCO INHIBIT = GND, and PFD is inhibited.

PFD section

PARAMETER		TEST CONDITIONS	MIN	TYP	MAX	UNIT
V_{OH}	High-level output voltage	$I_{OH} = 2\text{ mA}$	4.5			V
V_{OL}	Low-level output voltage	$I_{OL} = 2\text{ mA}$			0.2	V
I_{OZ}	High-impedance-state output current	PFD INHIBIT = high, $V_I = V_{DD}$ or GND			± 1	μA
V_{IH}	High-level input voltage at FIN-A, FIN-B		4.5			V
V_{IL}	Low-level input voltage at FIN-A, FIN-B				1	V
V_{IT}	Input threshold voltage at PFD INHIBIT		1.5	2.5	3.5	V
C_i	Input capacitance at FIN-A, FIN-B			5		pF
Z_i	Input impedance at FIN-A, FIN-B			10		$\text{M}\Omega$
$I_{DD}(\text{Z})$	High-impedance-state PFD supply current	See Note 6		0.01	1	μA
$I_{DD}(\text{PFD})$	PFD supply current	See Note 7		0.15	3	mA

NOTES: 6. Current into LOGIC V_{DD} , when FIN-A, FIN-B = GND, PFD INHIBIT = V_{DD} , no load, and VCO OUT is inhibited.

7. Current into LOGIC V_{DD} , when FIN-A, FIN-B = 1 MHz ($V_{I(\text{PP})} = 5\text{ V}$, rectangular wave), PFD INHIBIT = GND, no load, and VCO OUT is inhibited.

TLC2932

HIGH-PERFORMANCE PHASE-LOCKED LOOP

SLAS097E – SEPTEMBER 1994 – REVISED MAY 1997

operating characteristics over recommended operating free-air temperature range, $V_{DD} = 5\text{ V}$ (unless otherwise noted)

VCO section

PARAMETER		TEST CONDITIONS	MIN	TYP	MAX	UNIT
f_{osc}	Operating oscillation frequency	$R_{BIAS} = 2.2\text{ k}\Omega$, $VCO\ IN = 1/2\ V_{DD}$	30	41	52	MHz
$t_s(f_{osc})$	Time to stable oscillation (see Note 8)	Measured from VCO INHIBIT↓			10	μs
t_r	Rise time	$C_L = 15\text{ pF}$, See Figure 3		5.5	10	ns
		$C_L = 50\text{ pF}$, See Figure 3		8		
t_f	Fall time	$C_L = 15\text{ pF}$, See Figure 3		5	10	ns
		$C_L = 50\text{ pF}$, See Figure 3		6		
Duty cycle at VCO OUT		$R_{BIAS} = 2.2\text{ k}\Omega$, $VCO\ IN = 1/2\ V_{DD}$	45%	50%	55%	
$\alpha(f_{osc})$	Temperature coefficient of oscillation frequency	$R_{BIAS} = 2.2\text{ k}\Omega$, $VCO\ IN = 1/2\ V_{DD}$, $T_A = -20^\circ\text{C}$ to 75°C		0.06		$\%/^\circ\text{C}$
$k_{SVS}(f_{osc})$	Supply voltage coefficient of oscillation frequency	$R_{BIAS} = 2.2\text{ k}\Omega$, $VCO\ IN = 2.5\text{ V}$, $V_{DD} = 4.75\text{ V}$ to 5.25 V		0.006		$\%/mV$
Jitter absolute (see Note 9)		$R_{BIAS} = 2.2\text{ k}\Omega$		100		ps

NOTES: 8: The time period to the stable VCO oscillation frequency after the VCO INHIBIT terminal is changed to a low level.
 9: The LPF circuit is shown in Figure 28 with calculated values listed in Table 7. Jitter performance is highly dependent on circuit layout and external device characteristics. The jitter specification was made with a carefully designed PCB with no device socket.

PFD section

PARAMETER		TEST CONDITIONS	MIN	TYP	MAX	UNIT
f_{max}	Maximum operating frequency		40			MHz
t_{PLZ}	PFD output disable time from low level	See Figures 4 and 5 and Table 4		21	40	ns
t_{PHZ}	PFD output disable time from high level			20	40	
t_{PZL}	PFD output enable time to low level			7.3	20	ns
t_{PZH}	PFD output enable time to high level			6.5	20	
t_r	Rise time	$C_L = 15\text{ pF}$, See Figure 4		2.3	10	ns
t_f	Fall time			1.7	10	ns



PARAMETER MEASUREMENT INFORMATION

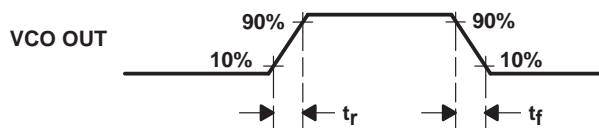
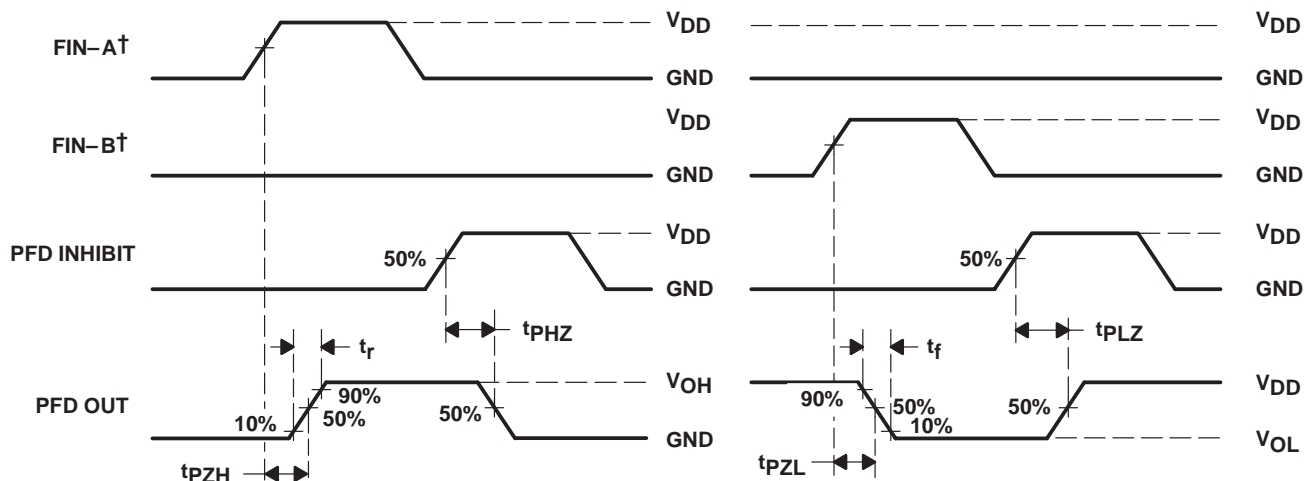

Figure 3. VCO Output Voltage Waveform



(a) OUTPUT PULLDOWN
(see Figure 5 and Table 4)

(b) OUTPUT PULLUP
(see Figure 5 and Table 4)

† FIN-A and FIN-B are for reference phase only, not for timing.

Figure 4. PFD Output Voltage Waveform

Table 4. PFD Output Test Conditions

PARAMETER	R_L	C_L	S_1	S_2
t_{PZH}	1 k Ω	15 pF	Open	Close
t_{PHZ}				
t_r				
t_{PZL}			Close	Open
t_{PLZ}				
t_f				

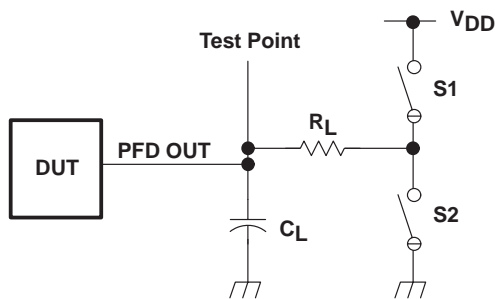

Figure 5. PFD Output Test Conditions

TYPICAL CHARACTERISTICS

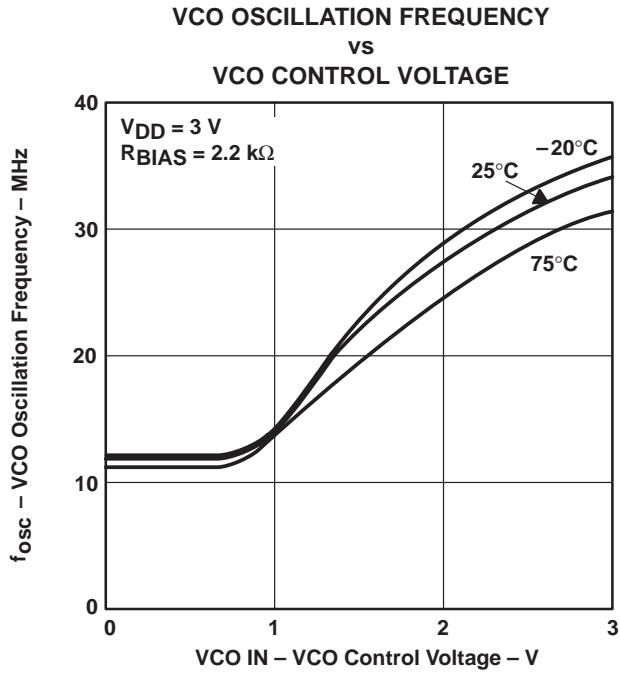

Figure 6

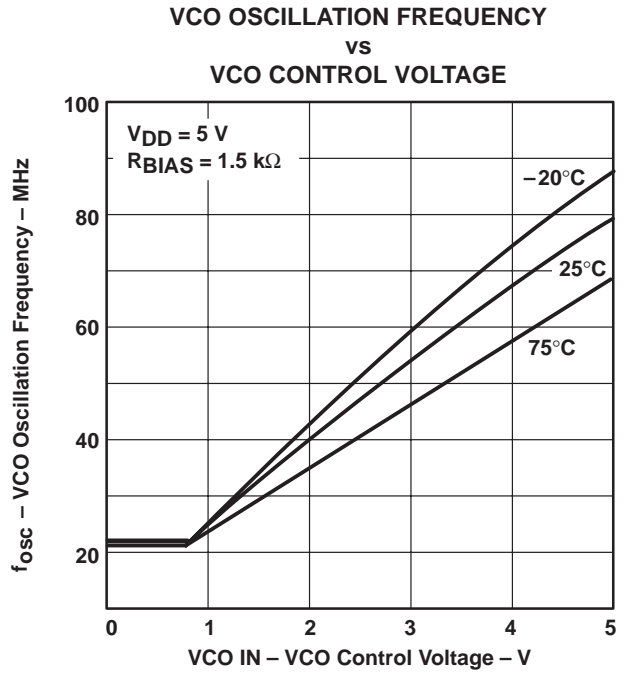

Figure 7

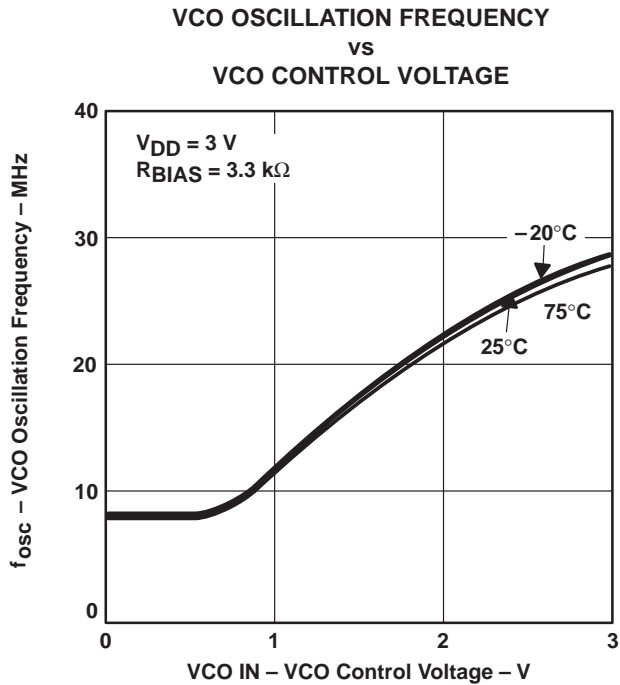

Figure 8

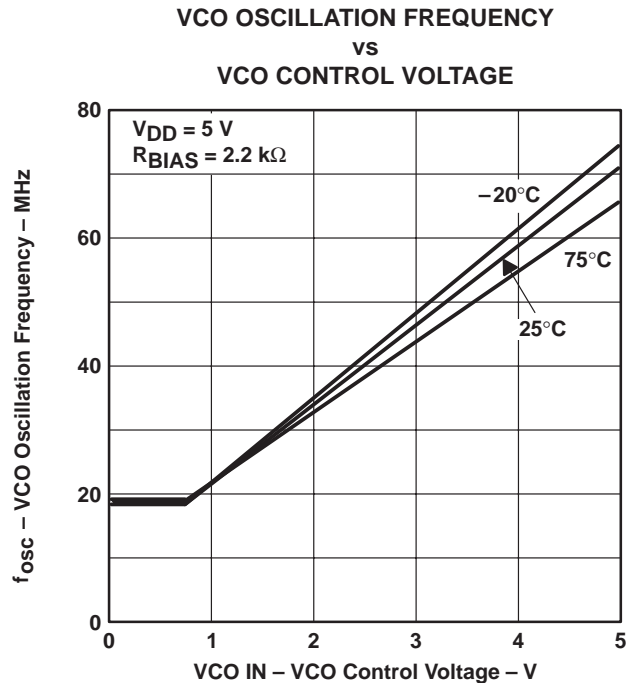

Figure 9

TYPICAL CHARACTERISTICS

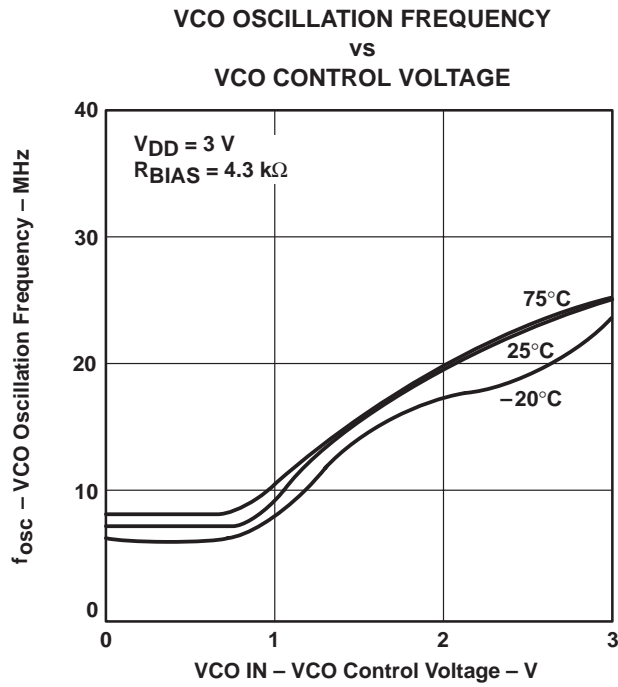

Figure 10

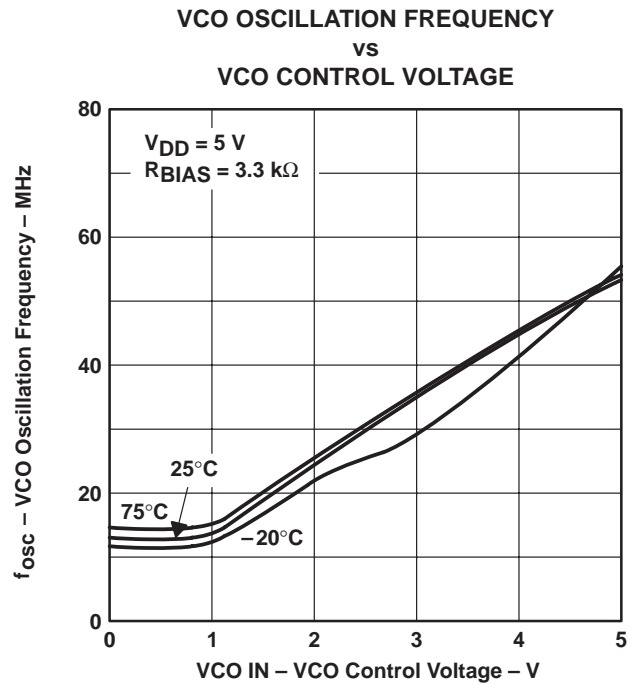

Figure 11

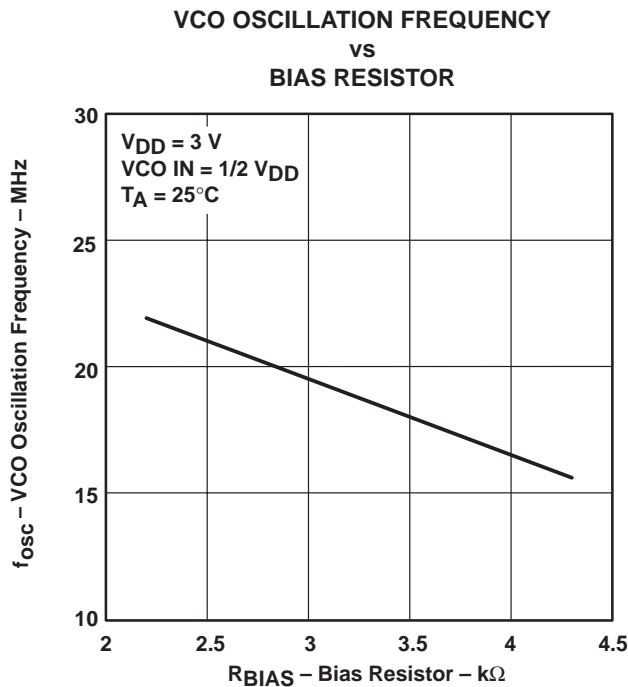

Figure 12

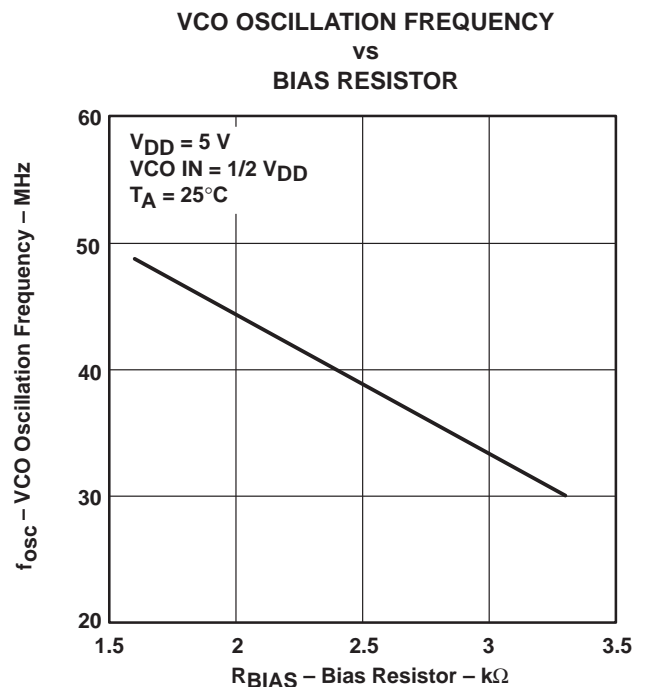

Figure 13

TLC2932 HIGH-PERFORMANCE PHASE-LOCKED LOOP

SLAS097E – SEPTEMBER 1994 – REVISED MAY 1997

TYPICAL CHARACTERISTICS

TEMPERATURE COEFFICIENT OF
OSCILLATION FREQUENCY
VS
BIAS RESISTOR

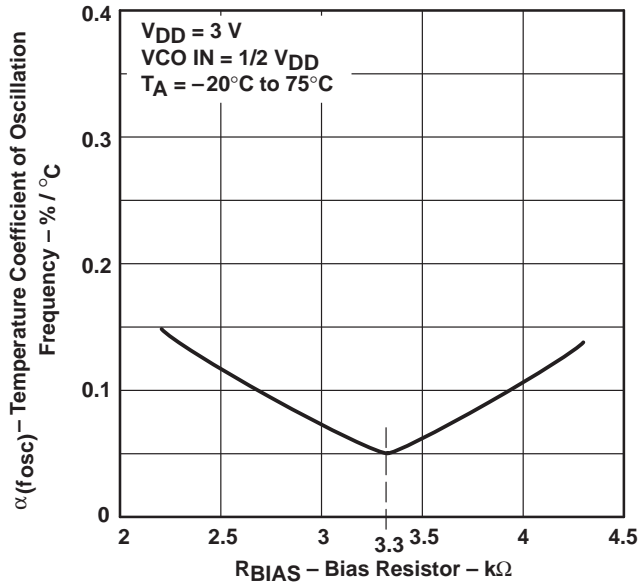

Figure 14

TEMPERATURE COEFFICIENT OF
OSCILLATION FREQUENCY
VS
BIAS RESISTOR

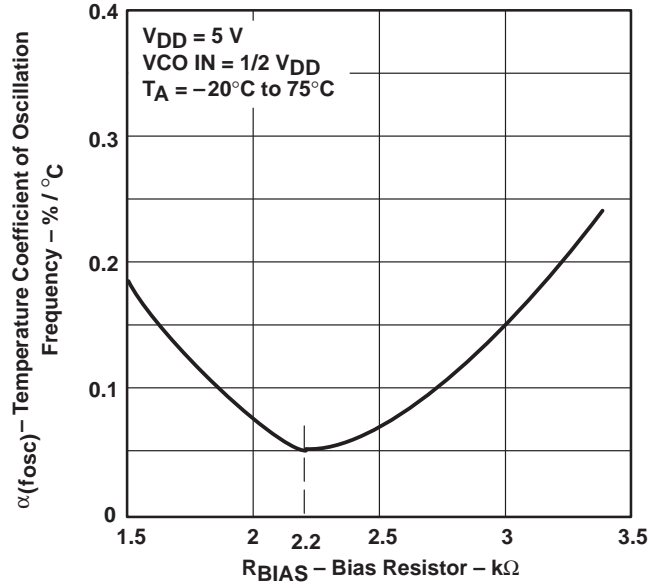

Figure 15

VCO OSCILLATION FREQUENCY
VS
VCO SUPPLY VOLTAGE

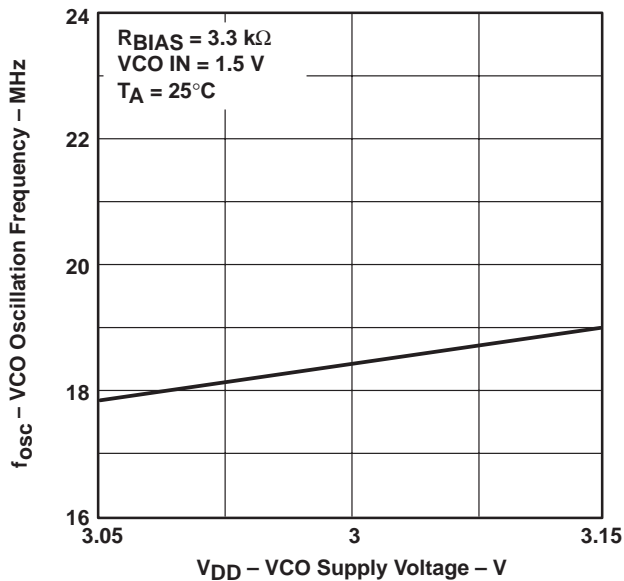

Figure 16

VCO OSCILLATION FREQUENCY
VS
VCO SUPPLY VOLTAGE

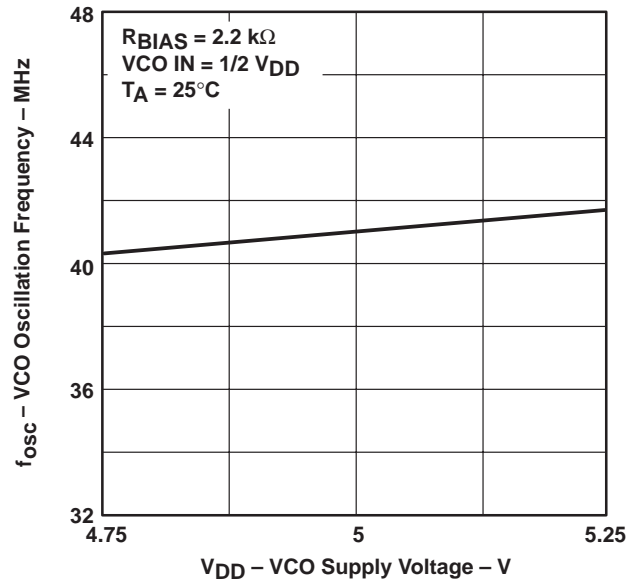

Figure 17



TYPICAL CHARACTERISTICS

SUPPLY VOLTAGE COEFFICIENT OF VCO
OSCILLATION FREQUENCY

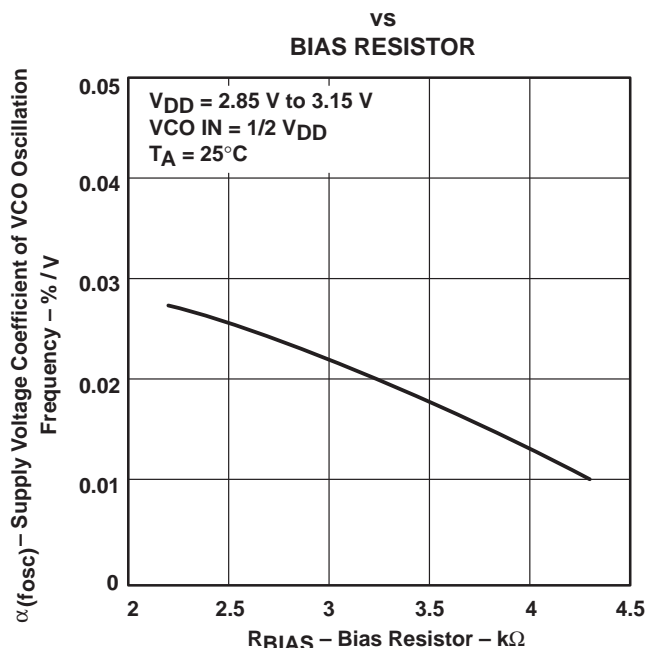

Figure 18

SUPPLY VOLTAGE COEFFICIENT OF VCO
OSCILLATION FREQUENCY

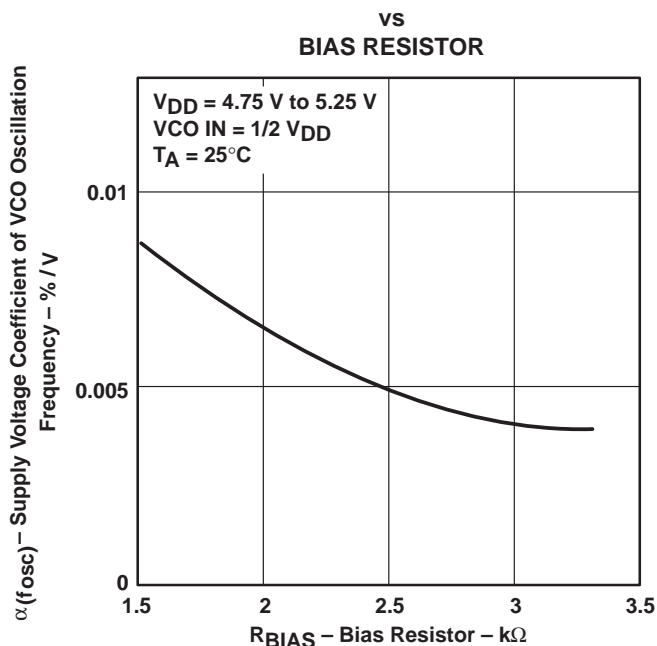

Figure 19

RECOMMENDED LOCK FREQUENCY

($\times 1$ OUTPUT)

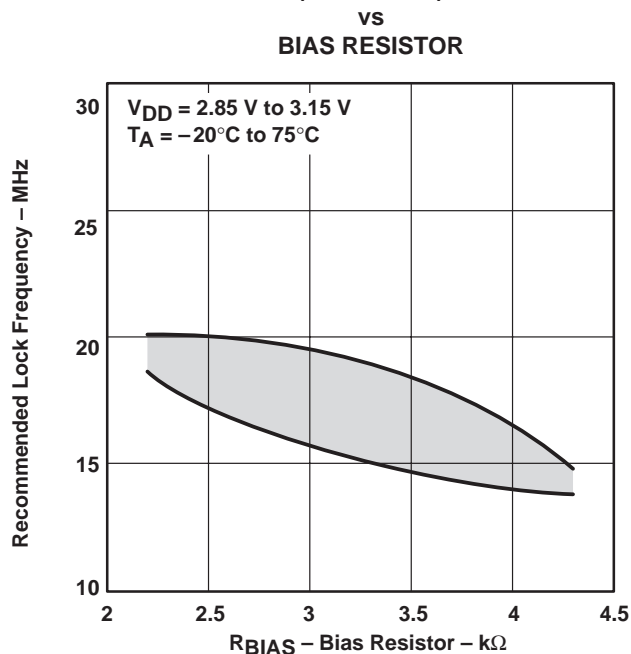

Figure 20

RECOMMENDED LOCK FREQUENCY

($\times 1$ OUTPUT)

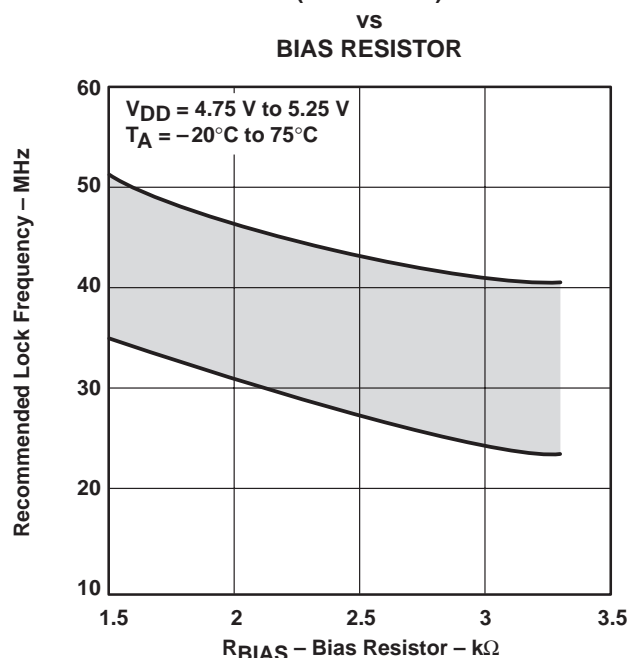

Figure 21

APPLICATION INFORMATION

RECOMMENDED LOCK FREQUENCY
($\times 1/2$ OUTPUT)
vs
BIAS RESISTOR

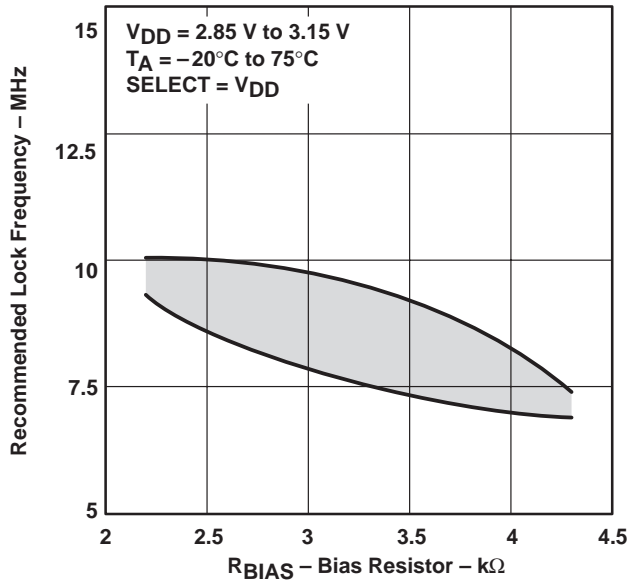

Figure 22

RECOMMENDED LOCK FREQUENCY
($\times 1/2$ OUTPUT)
vs
BIAS RESISTOR

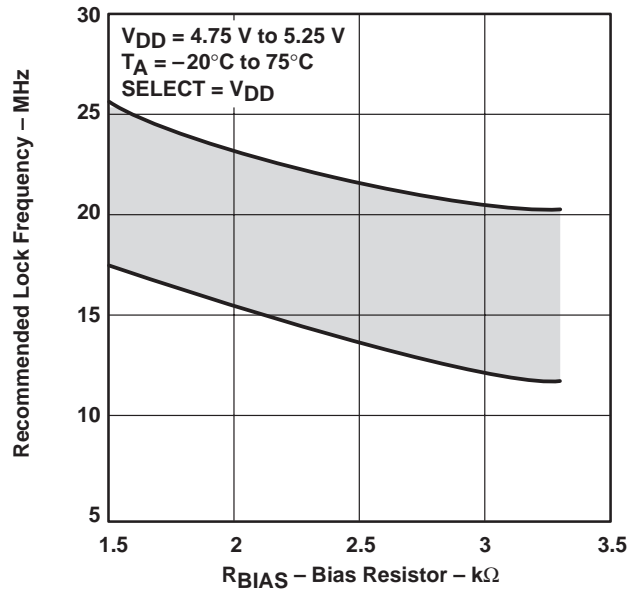

Figure 23

APPLICATION INFORMATION

gain of VCO and PFD

Figure 24 is a block diagram of the PLL. The countdown N value depends on the input frequency and the desired VCO output frequency according to the system application requirements. The K_p and K_V values are obtained from the operating characteristics of the device as shown in Figure 24. K_p is defined from the phase detector V_{OL} and V_{OH} specifications and the equation shown in Figure 24(b). K_V is defined from Figures 8, 9, 10, and 11 as shown in Figure 24(c).

The parameters for the block diagram with the units are as follows:

- K_V : VCO gain (rad/s/V)
- K_p : PFD gain (V/rad)
- K_f : LPF gain (V/V)
- K_N : count down divider gain (1/N)

external counter

When a large N counter is required by the application, there is a possibility that the PLL response becomes slow due to the counter response delay time. In the case of a high frequency application, the counter delay time should be accounted for in the overall PLL design.

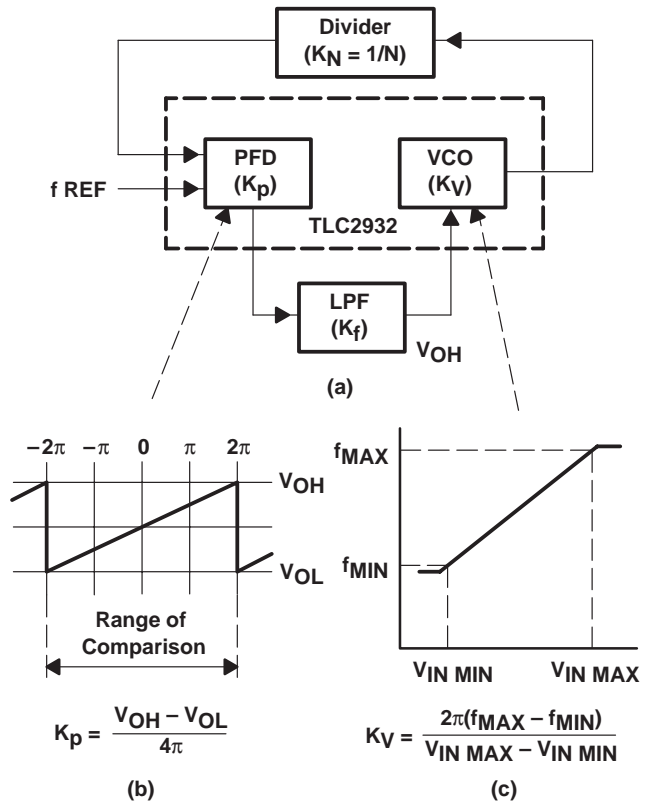

Figure 24. Example of a PLL Block Diagram

RBIAS

The external bias resistor sets the VCO center frequency with $1/2 V_{DD}$ applied to the VCO IN terminal. However, for optimum temperature performance, a resistor value of 3.3 kΩ with a 3-V supply and a resistor value of 2.5 kΩ for a 5-V supply is recommended. For the most accurate results, a metal-film resistor is the better choice but a carbon-composition resistor can be used with excellent results also. A 0.22 μF capacitor should be connected from the BIAS terminal to ground as close to the device terminals as possible.

hold-in range

From the technical literature, the maximum hold-in range for an input frequency step for the three types of filter configurations shown in Figure 25 is as follows:

$$\Delta\omega_H \approx 0.8 (K_p) (K_V) (K_f(\infty))$$

Where

$$K_f(\infty) = \text{the filter transfer function value at } \omega = \infty$$

APPLICATION INFORMATION

low-pass-filter (LPF) configurations

Many excellent references are available that include detailed design information about LPFs and should be consulted for additional information. Lag-lead filters or active filters are often used. Examples of LPFs are shown in Figure 25. When the active filter of Figure 25(c) is used, the reference should be applied to FIN-B because of the amplifier inversion. Also, in practical filter implementations, C2 is used as additional filtering at the VCO input. The value of C2 should be equal to or less than one tenth the value of C1.

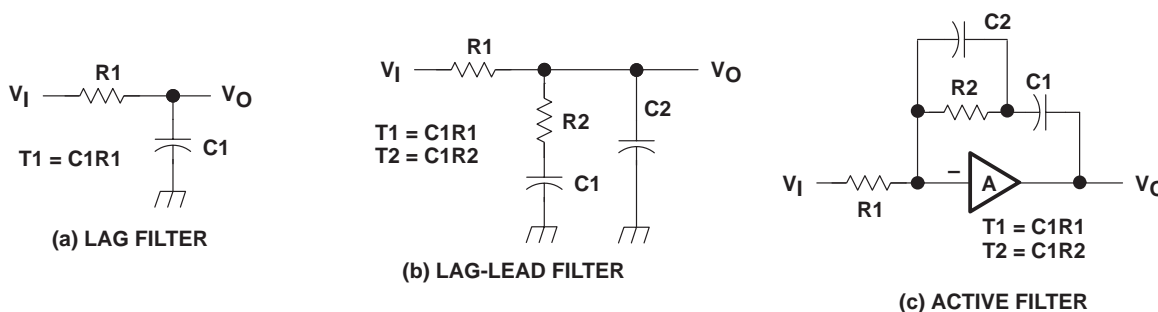

Figure 25. LPF Examples for PLL

the passive filter

The transfer function for the lag-lead filter shown in Figure 25(b) is;

$$\frac{V_O}{V_{IN}} = \frac{1 + s \cdot T2}{1 + s \cdot (T1 + T2)}$$

Where

$$T1 = R1 \cdot C1 \text{ and } T2 = R2 \cdot C1$$

Using this filter makes the closed loop PLL system a second-order type 1 system. The response curves of this system to a unit step are shown in Figure 26.

the active filter

When using the active integrator shown in Figure 25(c), the phase detector inputs must be reversed since the integrator adds an additional inversion. Therefore, the input reference frequency should be applied to the FIN-B terminal and the output of the VCO divider should be applied to the input reference terminal, FIN-A.

The transfer function for the active filter shown in Figure 25(c) is:

$$F(s) = \frac{1 + s \cdot R2 \cdot C1}{s \cdot R1 \cdot C1}$$

Using this filter makes the closed loop PLL system a second-order type 2 system. The response curves of this system to a unit step are shown in Figure 27.

basic design example

The following design example presupposes that the input reference frequency and the required frequency of the VCO are within the respective ranges of the device.

APPLICATION INFORMATION

basic design example (continued)

Assume the loop has to have a 100 μs settling time (t_s) with a countdown $N = 8$. Using the Type 1, second order response curves of Figure 26, a value of 4.5 radians is selected for $\omega_n t_s$ with a damping factor of 0.7. This selection gives a good combination for settling time, accuracy, and loop gain margin. The initial parameters are summarized in Table 5. The loop constants, K_V and K_P , are calculated from the data sheet specifications and Table 6 shows these values.

The natural loop frequency is calculated as follows:

Since

$$\omega_n t_s = 4.5$$

Then

$$\omega_n = \frac{4.5}{100 \mu\text{s}} = 45 \text{ k-radians/sec}$$

Table 5. Design Parameters

PARAMETER	SYMBOL	VALUE	UNITS
Division factor	N	8	
Lockup time	t	100	μs
Radian value to selected lockup time	$\omega_n t$	4.5	rad
Damping factor	ζ	0.7	

Table 6. Device Specifications

PARAMETER	SYMBOL	VALUE	UNITS
VCO gain		76.6	Mrad/V/s
f_{MAX}	K_V	70	MHz
f_{MIN}		20	MHz
$V_{\text{IN MAX}}$		5	V
$V_{\text{IN MIN}}$		0.9	V
PFD gain	K_P	0.342357	V/rad

Table 7. Calculated Values

PARAMETER	SYMBOL	VALUE	UNITS
Natural angular frequency	ω_n	45000	rad/sec
$K = (K_V \cdot K_P)/N$		3.277	Mrad/sec
Lag-lead filter			
Calculated value	R1	15870	Ω
Nearest standard value		16000	
Calculated value	R2	308	Ω
Nearest standard value		300	
Selected value	C1	0.1	μF

TLC2932 HIGH-PERFORMANCE PHASE-LOCKED LOOP

SLAS097E – SEPTEMBER 1994 – REVISED MAY 1997

APPLICATION INFORMATION

Using the low-pass filter in Figure 25(b) and divider ratio N, the transfer function for phase and frequency are shown in equations 1 and 2. Note that the transfer function for phase differs from the transfer function for frequency by only the divider value N. The difference arises from the fact that the feedback for phase is unity while the feedback for frequency is 1/N.

Hence, transfer function of Figure 24 (a) for phase is

$$\frac{\Phi_2(s)}{\Phi_1(s)} = \frac{K_p \cdot K_V}{N \cdot (T_1 + T_2)} \left[\frac{1 + s \cdot T_2}{s^2 + s \left[1 + \frac{K_p \cdot K_V \cdot T_2}{N \cdot (T_1 + T_2)} \right] + \frac{K_p \cdot K_V}{N \cdot (T_1 + T_2)}} \right] \quad (1)$$

and the transfer function for frequency is

$$\frac{F_{OUT}(s)}{F_{REF}(s)} = \frac{K_p \cdot K_V}{(T_1 + T_2)} \left[\frac{1 + s \cdot T_2}{s^2 + s \cdot \left[1 + \frac{K_p \cdot K_V \cdot T_2}{N \cdot (T_1 + T_2)} \right] + \frac{K_p \cdot K_V}{N \cdot (T_1 + T_2)}} \right] \quad (2)$$

The standard two-pole denominator is $D = s^2 + 2 \zeta \omega_n s + \omega_n^2$ and comparing the coefficients of the denominator of equation 1 and 2 with the standard two-pole denominator gives the following results.

$$\omega_n = \sqrt{\frac{K_p \cdot K_V}{N \cdot (T_1 + T_2)}}$$

Solving for $T_1 + T_2$

$$T_1 + T_2 = \frac{K_p \cdot K_V}{N \cdot \omega_n^2} \quad (3)$$

and by using this value for $T_1 + T_2$ in equation 3 the damping factor is

$$\zeta = \frac{\omega_n}{2} \cdot \left(T_2 + \frac{N}{K_p \cdot K_V} \right)$$

solving for T_2

$$T_2 = \frac{2 \zeta}{\omega_n} - \frac{N}{K_p \cdot K_V}$$

then by substituting for T_2 in equation 3

$$T_1 = \frac{K_V \cdot K_p}{N \cdot \omega_n^2} - \frac{2 \zeta}{\omega_n} + \frac{N}{K_p \cdot K_V}$$

APPLICATION INFORMATION

From the circuit constants and the initial design parameters then

$$R2 = \left[\frac{2 \zeta}{\omega_n} - \frac{N}{K_p \cdot K_V} \right] \frac{1}{C1}$$

$$R1 = \left[\frac{K_p \cdot K_V}{\omega_n^2 \cdot N} - \frac{2 \zeta}{\omega_n} + \frac{N}{K_p \cdot K_V} \right] \frac{1}{C1}$$

The capacitor, C1, is usually chosen between 1 μF and 0.1 μF to allow for reasonable resistor values and physical capacitor size. In this example, C1 is chosen to be 0.1 μF and the corresponding R1 and R2 calculated values are listed in Table 7.

APPLICATION INFORMATION

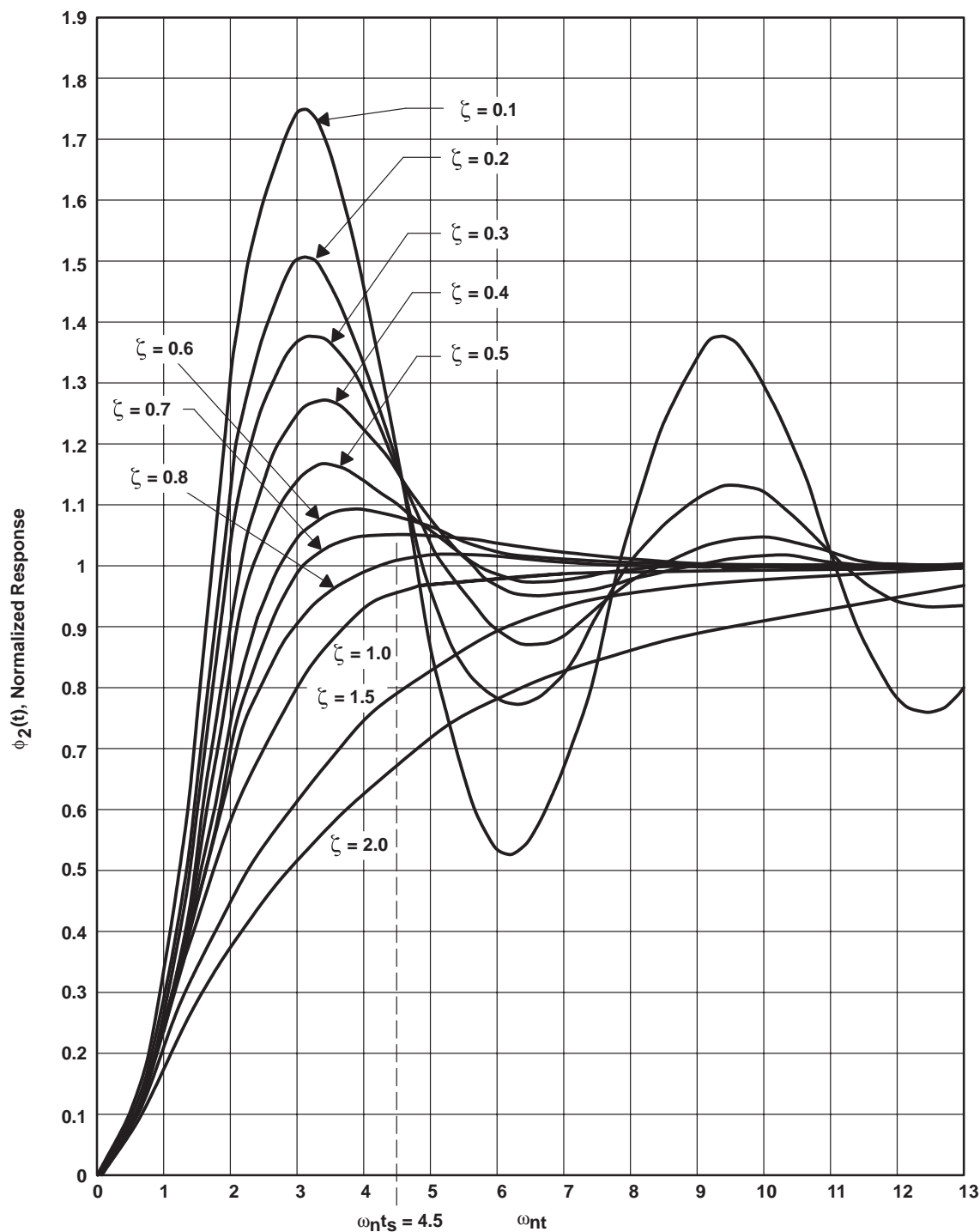

Figure 26. Type 1 Second-Order Step Response

APPLICATION INFORMATION

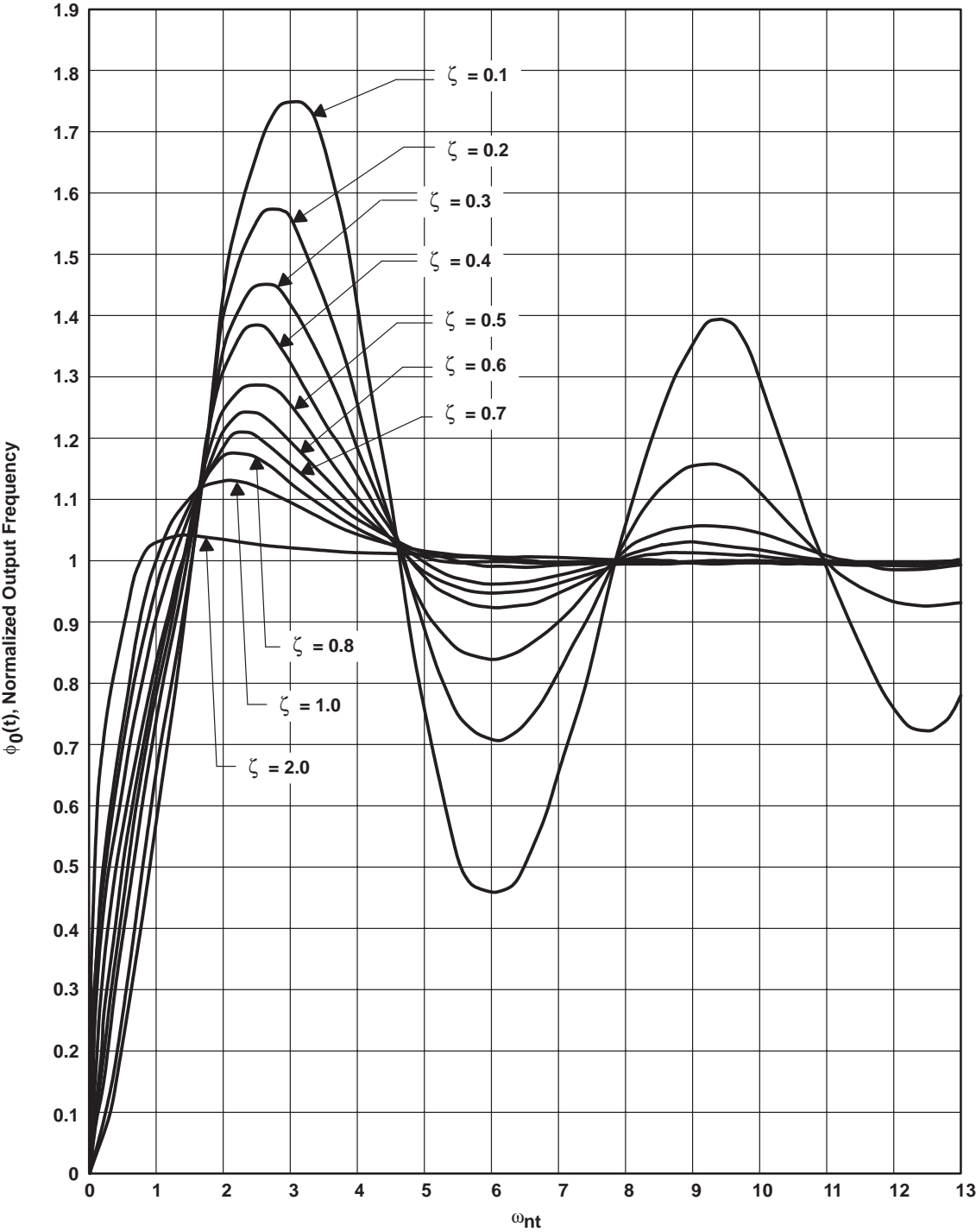

Figure 27. Type 2 Second-Order Step Response

TLC2932 HIGH-PERFORMANCE PHASE-LOCKED LOOP

SLAS097E – SEPTEMBER 1994 – REVISED MAY 1997

APPLICATION INFORMATION

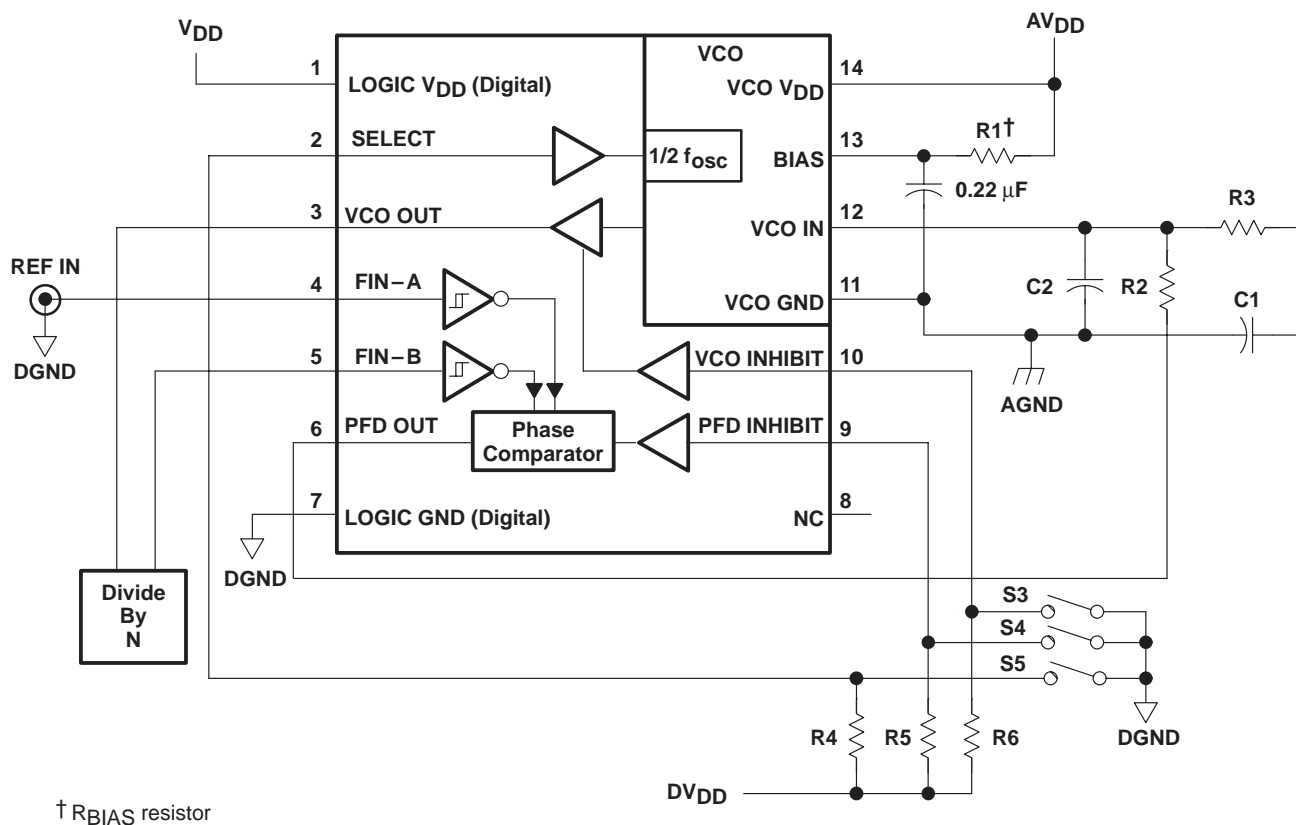

Figure 28. Evaluation and Operation Schematic

PCB layout considerations

The TLC2932 contains a high frequency analog oscillator; therefore, very careful breadboarding and printed-circuit-board (PCB) layout is required for evaluation.

The following design recommendations benefit the TLC2932 user:

- External analog and digital circuitry should be physically separated and shielded as much as possible to reduce system noise.
- RF breadboarding or RF PCB techniques should be used throughout the evaluation and production process.
- Wide ground leads or a ground plane should be used on the PCB layouts to minimize parasitic inductance and resistance. The ground plane is the better choice for noise reduction.
- LOGIC V_{DD} and VCO V_{DD} should be separate PCB traces and connected to the best filtered supply point available in the system to minimize supply cross-coupling.
- VCO V_{DD} to GND and LOGIC V_{DD} to GND should be decoupled with a 0.1-μF capacitor placed as close as possible to the appropriate device terminals.
- The no-connection (NC) terminal on the package should be connected to GND.

PACKAGING INFORMATION

Orderable Device	Status (1)	Package Type	Package Drawing	Pins	Package Qty	Eco Plan (2)	Lead/Ball Finish	MSL Peak Temp (3)	Op Temp (°C)	Top-Side Markings (4)	Samples
TLC2932IPW	NRND	TSSOP	PW	14	90	Green (RoHS & no Sb/Br)	CU NIPDAU	Level-1-260C-UNLIM		Y2932	
TLC2932IPWG4	NRND	TSSOP	PW	14	90	Green (RoHS & no Sb/Br)	CU NIPDAU	Level-1-260C-UNLIM	-40 to 85	Y2932	
TLC2932IPWLE	OBSOLETE	TSSOP	PW	14		TBD	Call TI	Call TI			
TLC2932IPWR	NRND	TSSOP	PW	14	2000	Green (RoHS & no Sb/Br)	CU NIPDAU	Level-1-260C-UNLIM		Y2932	
TLC2932IPWRG4	NRND	TSSOP	PW	14	2000	Green (RoHS & no Sb/Br)	CU NIPDAU	Level-1-260C-UNLIM	-40 to 85	Y2932	

(1) The marketing status values are defined as follows:

ACTIVE: Product device recommended for new designs.

LIFEBUY: TI has announced that the device will be discontinued, and a lifetime-buy period is in effect.

NRND: Not recommended for new designs. Device is in production to support existing customers, but TI does not recommend using this part in a new design.

PREVIEW: Device has been announced but is not in production. Samples may or may not be available.

OBSOLETE: TI has discontinued the production of the device.

(2) Eco Plan - The planned eco-friendly classification: Pb-Free (RoHS), Pb-Free (RoHS Exempt), or Green (RoHS & no Sb/Br) - please check <http://www.ti.com/productcontent> for the latest availability information and additional product content details.

TBD: The Pb-Free/Green conversion plan has not been defined.

Pb-Free (RoHS): TI's terms "Lead-Free" or "Pb-Free" mean semiconductor products that are compatible with the current RoHS requirements for all 6 substances, including the requirement that lead not exceed 0.1% by weight in homogeneous materials. Where designed to be soldered at high temperatures, TI Pb-Free products are suitable for use in specified lead-free processes.

Pb-Free (RoHS Exempt): This component has a RoHS exemption for either 1) lead-based flip-chip solder bumps used between the die and package, or 2) lead-based die adhesive used between the die and leadframe. The component is otherwise considered Pb-Free (RoHS compatible) as defined above.

Green (RoHS & no Sb/Br): TI defines "Green" to mean Pb-Free (RoHS compatible), and free of Bromine (Br) and Antimony (Sb) based flame retardants (Br or Sb do not exceed 0.1% by weight in homogeneous material)

(3) MSL, Peak Temp. -- The Moisture Sensitivity Level rating according to the JEDEC industry standard classifications, and peak solder temperature.

(4) Multiple Top-Side Markings will be inside parentheses. Only one Top-Side Marking contained in parentheses and separated by a "~" will appear on a device. If a line is indented then it is a continuation of the previous line and the two combined represent the entire Top-Side Marking for that device.

Important Information and Disclaimer: The information provided on this page represents TI's knowledge and belief as of the date that it is provided. TI bases its knowledge and belief on information provided by third parties, and makes no representation or warranty as to the accuracy of such information. Efforts are underway to better integrate information from third parties. TI has taken and continues to take reasonable steps to provide representative and accurate information but may not have conducted destructive testing or chemical analysis on incoming materials and chemicals. TI and TI suppliers consider certain information to be proprietary, and thus CAS numbers and other limited information may not be available for release.

In no event shall TI's liability arising out of such information exceed the total purchase price of the TI part(s) at issue in this document sold by TI to Customer on an annual basis.

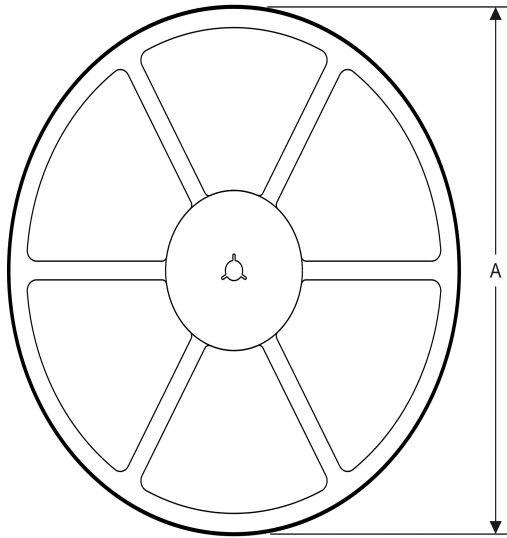
TAPE AND REEL INFORMATION
REEL DIMENSIONS

TAPE DIMENSIONS



A0	Dimension designed to accommodate the component width
B0	Dimension designed to accommodate the component length
K0	Dimension designed to accommodate the component thickness
W	Overall width of the carrier tape
P1	Pitch between successive cavity centers

TAPE AND REEL INFORMATION

*All dimensions are nominal

Device	Package Type	Package Drawing	Pins	SPQ	Reel Diameter (mm)	Reel Width W1 (mm)	A0 (mm)	B0 (mm)	K0 (mm)	P1 (mm)	W (mm)	Pin1 Quadrant
TLC2932IPWR	TSSOP	PW	14	2000	330.0	12.4	6.9	5.6	1.6	8.0	12.0	Q1

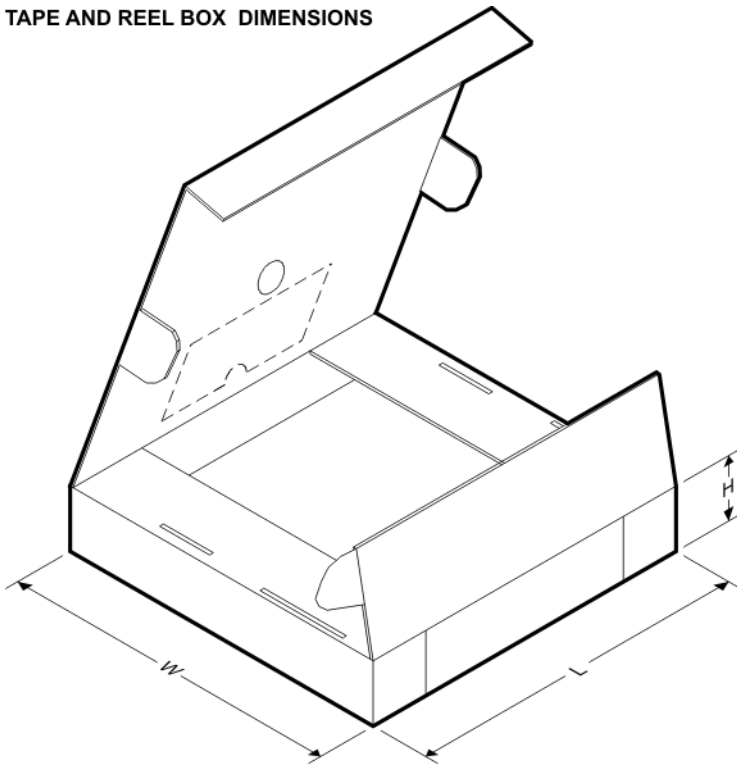
TAPE AND REEL BOX DIMENSIONS



*All dimensions are nominal

Device	Package Type	Package Drawing	Pins	SPQ	Length (mm)	Width (mm)	Height (mm)
TLC2932IPWR	TSSOP	PW	14	2000	367.0	367.0	35.0

MECHANICAL DATA

PW (R-PDSO-G14)

PLASTIC SMALL OUTLINE

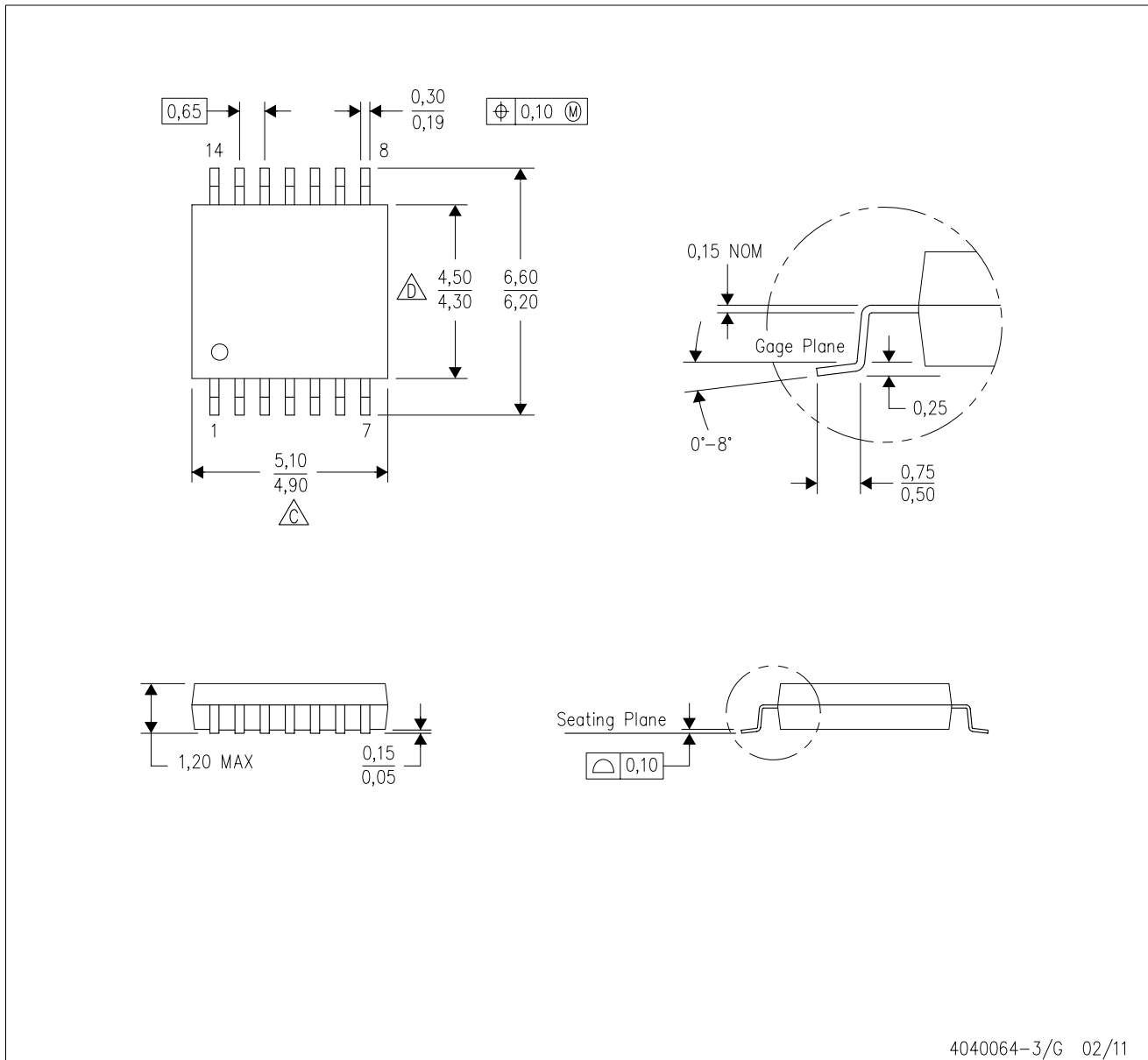

4040064-3/G 02/11

- NOTES:
- A. All linear dimensions are in millimeters. Dimensioning and tolerancing per ASME Y14.5M-1994.
 - B. This drawing is subject to change without notice.
 - C. Body length does not include mold flash, protrusions, or gate burrs. Mold flash, protrusions, or gate burrs shall not exceed 0,15 each side.
 - D. Body width does not include interlead flash. Interlead flash shall not exceed 0,25 each side.
 - E. Falls within JEDEC MO-153

PW (R-PDSO-G14)

PLASTIC SMALL OUTLINE



4211284-2/G 08/15

- NOTES:
- All linear dimensions are in millimeters.
 - This drawing is subject to change without notice.
 - Publication IPC-7351 is recommended for alternate designs.
 - Laser cutting apertures with trapezoidal walls and also rounding corners will offer better paste release. Customers should contact their board assembly site for stencil design recommendations. Refer to IPC-7525 for other stencil recommendations.
 - Customers should contact their board fabrication site for solder mask tolerances between and around signal pads.

IMPORTANT NOTICE

Texas Instruments Incorporated and its subsidiaries (TI) reserve the right to make corrections, enhancements, improvements and other changes to its semiconductor products and services per JESD46, latest issue, and to discontinue any product or service per JESD48, latest issue. Buyers should obtain the latest relevant information before placing orders and should verify that such information is current and complete. All semiconductor products (also referred to herein as "components") are sold subject to TI's terms and conditions of sale supplied at the time of order acknowledgment.

TI warrants performance of its components to the specifications applicable at the time of sale, in accordance with the warranty in TI's terms and conditions of sale of semiconductor products. Testing and other quality control techniques are used to the extent TI deems necessary to support this warranty. Except where mandated by applicable law, testing of all parameters of each component is not necessarily performed.

TI assumes no liability for applications assistance or the design of Buyers' products. Buyers are responsible for their products and applications using TI components. To minimize the risks associated with Buyers' products and applications, Buyers should provide adequate design and operating safeguards.

TI does not warrant or represent that any license, either express or implied, is granted under any patent right, copyright, mask work right, or other intellectual property right relating to any combination, machine, or process in which TI components or services are used. Information published by TI regarding third-party products or services does not constitute a license to use such products or services or a warranty or endorsement thereof. Use of such information may require a license from a third party under the patents or other intellectual property of the third party, or a license from TI under the patents or other intellectual property of TI.

Reproduction of significant portions of TI information in TI data books or data sheets is permissible only if reproduction is without alteration and is accompanied by all associated warranties, conditions, limitations, and notices. TI is not responsible or liable for such altered documentation. Information of third parties may be subject to additional restrictions.

Resale of TI components or services with statements different from or beyond the parameters stated by TI for that component or service voids all express and any implied warranties for the associated TI component or service and is an unfair and deceptive business practice. TI is not responsible or liable for any such statements.

Buyer acknowledges and agrees that it is solely responsible for compliance with all legal, regulatory and safety-related requirements concerning its products, and any use of TI components in its applications, notwithstanding any applications-related information or support that may be provided by TI. Buyer represents and agrees that it has all the necessary expertise to create and implement safeguards which anticipate dangerous consequences of failures, monitor failures and their consequences, lessen the likelihood of failures that might cause harm and take appropriate remedial actions. Buyer will fully indemnify TI and its representatives against any damages arising out of the use of any TI components in safety-critical applications.

In some cases, TI components may be promoted specifically to facilitate safety-related applications. With such components, TI's goal is to help enable customers to design and create their own end-product solutions that meet applicable functional safety standards and requirements. Nonetheless, such components are subject to these terms.

No TI components are authorized for use in FDA Class III (or similar life-critical medical equipment) unless authorized officers of the parties have executed a special agreement specifically governing such use.

Only those TI components which TI has specifically designated as military grade or "enhanced plastic" are designed and intended for use in military/aerospace applications or environments. Buyer acknowledges and agrees that any military or aerospace use of TI components which have **not** been so designated is solely at the Buyer's risk, and that Buyer is solely responsible for compliance with all legal and regulatory requirements in connection with such use.

TI has specifically designated certain components as meeting ISO/TS16949 requirements, mainly for automotive use. In any case of use of non-designated products, TI will not be responsible for any failure to meet ISO/TS16949.

Products

Audio	www.ti.com/audio
Amplifiers	amplifier.ti.com
Data Converters	dataconverter.ti.com
DLP® Products	www.dlp.com
DSP	dsp.ti.com
Clocks and Timers	www.ti.com/clocks
Interface	interface.ti.com
Logic	logic.ti.com
Power Mgmt	power.ti.com
Microcontrollers	microcontroller.ti.com
RFID	www.ti-rfid.com
OMAP Applications Processors	www.ti.com/omap
Wireless Connectivity	www.ti.com/wirelessconnectivity

Applications

Automotive and Transportation	www.ti.com/automotive
Communications and Telecom	www.ti.com/communications
Computers and Peripherals	www.ti.com/computers
Consumer Electronics	www.ti.com/consumer-apps
Energy and Lighting	www.ti.com/energy
Industrial	www.ti.com/industrial
Medical	www.ti.com/medical
Security	www.ti.com/security
Space, Avionics and Defense	www.ti.com/space-avionics-defense
Video and Imaging	www.ti.com/video

TI E2E Community

e2e.ti.com