

# TLC27L2, TLC27L2A, TLC27L2B, TLC27L7 LinCMOS™ PRECISION DUAL OPERATIONAL AMPLIFIERS

SLOS052C – OCTOBER 1987 – REVISED MARCH 2001

- **Trimmed Offset Voltage:**  
TLC27L7 . . . 500  $\mu\text{V}$  Max at 25°C,  
 $V_{\text{DD}} = 5\text{ V}$
- **Input Offset Voltage Drift . . . Typically**  
0.1  $\mu\text{V}/\text{Month}$ , Including the First 30 Days
- **Wide Range of Supply Voltages Over Specified Temperature Range:**  
0°C to 70°C . . . 3 V to 16 V  
–40°C to 85°C . . . 4 V to 16 V  
–55°C to 125°C . . . 4 V to 16 V
- **Single-Supply Operation**
- **Common-Mode Input Voltage Range Extends Below the Negative Rail (C-Suffix, I-Suffix Types)**
- **Ultra-Low Power . . . Typically 95  $\mu\text{W}$  at 25°C,  $V_{\text{DD}} = 5\text{ V}$**
- **Output Voltage Range Includes Negative Rail**
- **High Input Impedance . . .  $10^{12}\ \Omega$  Typ**
- **ESD-Protection Circuitry**
- **Small-Outline Package Option Also Available in Tape and Reel**
- **Designed-In Latch-Up immunity**

## description

The TLC27L2 and TLC27L7 dual operational amplifiers combine a wide range of input offset voltage grades with low offset voltage drift, high input impedance, extremely low power, and high gain.

### AVAILABLE OPTIONS

T <sub>A</sub>	V <sub>IO</sub> max AT 25°C	PACKAGE			
		SMALL OUTLINE (D)	CHIP CARRIER (FK)	CERAMIC DIP (JG)	PLASTIC DIP (P)
0°C to 70°C	500 $\mu\text{V}$ 2 mV 5 mV 10 mV	TLC27L7CD TLC27L2BCD TLC27L2ACD TLC27L2CD	—	—	TLC27L7CP TLC27L2BCP TLC27L2ACP TLC27L2CP
–40°C to 85°C	500 $\mu\text{V}$ 2 mV 5 mV 10 mV	TLC27L7ID TLC27L2BID TLC27L2AID TLC27L2ID	—	—	TLC27L7IP TLC27L2BIP TLC27L2AIP TLC27L2IP
–55°C to 125°C	500 $\mu\text{V}$ 10 mV	TLC27L7MD TLC27L2MD	TLC27L7MFK TLC27L2MFK	TLC27L7MJG TLC27L2MJG	TLC27L7MP TLC27L2MP

The D package is available taped and reeled. Add R suffix to the device type (e.g., TLC27L7CDR).

D, JG, OR P PACKAGE  
(TOP VIEW)

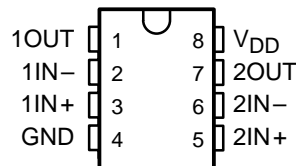

FK PACKAGE  
(TOP VIEW)

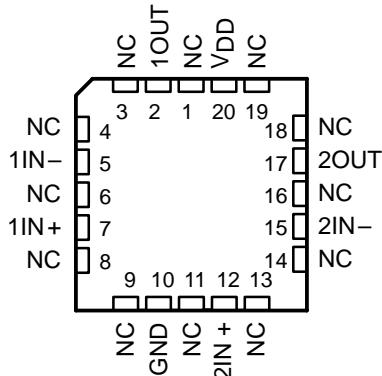

NC – No internal connection

DISTRIBUTION OF TLC27L7  
INPUT OFFSET VOLTAGE

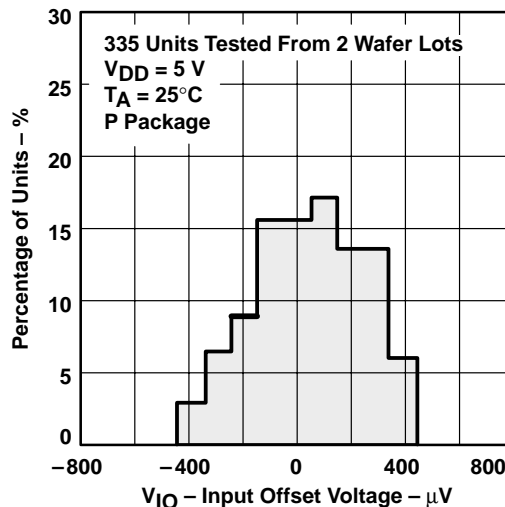

LinCMOS is a trademark of Texas Instruments.

PRODUCTION DATA information is current as of publication date. Products conform to specifications per the terms of Texas Instruments standard warranty. Production processing does not necessarily include testing of all parameters.



POST OFFICE BOX 655303 • DALLAS, TEXAS 75265

Copyright © 2001, Texas Instruments Incorporated

Orderable Device	Status <sup>(1)</sup>	Package Type	Package Drawing	Pins	Package Qty	Eco Plan <sup>(2)</sup>	Lead/Ball Finish	MSL Peak Temp <sup>(3)</sup>
						no Sb/Br)		
TLC27L2CP	ACTIVE	PDIP	P	8	50	Pb-Free (RoHS)	CU NIPDAU	Level-NC-NC-NC
TLC27L2CPE4	ACTIVE	PDIP	P	8	50	Pb-Free (RoHS)	CU NIPDAU	Level-NC-NC-NC
TLC27L2CPSR	ACTIVE	SO	PS	8	2000	TBD	CU NIPDAU	Level-1-220C-UNLIM
TLC27L2CPW	ACTIVE	TSSOP	PW	8	150	TBD	CU NIPDAU	Level-1-220C-UNLIM
TLC27L2CPWLE	OBSOLETE	TSSOP	PW	8		TBD	Call TI	Call TI
TLC27L2CPWR	ACTIVE	TSSOP	PW	8	2000	TBD	CU NIPDAU	Level-1-220C-UNLIM
TLC27L2ID	ACTIVE	SOIC	D	8	75	Green (RoHS & no Sb/Br)	CU NIPDAU	Level-1-260C-UNLIM
TLC27L2IDR	ACTIVE	SOIC	D	8	2500	Green (RoHS & no Sb/Br)	CU NIPDAU	Level-1-260C-UNLIM
TLC27L2IP	ACTIVE	PDIP	P	8	50	Pb-Free (RoHS)	CU NIPDAU	Level-NC-NC-NC
TLC27L2IPE4	ACTIVE	PDIP	P	8	50	Pb-Free (RoHS)	CU NIPDAU	Level-NC-NC-NC
TLC27L2IPW	ACTIVE	TSSOP	PW	8	150	TBD	CU NIPDAU	Level-1-220C-UNLIM
TLC27L2IPWLE	OBSOLETE	TSSOP	PW	8		TBD	Call TI	Call TI
TLC27L2IPWR	ACTIVE	TSSOP	PW	8	2000	TBD	CU NIPDAU	Level-1-220C-UNLIM
TLC27L2MD	ACTIVE	SOIC	D	8	75	TBD	CU NIPDAU	Level-1-220C-UNLIM
TLC27L2MDR	ACTIVE	SOIC	D	8	2500	TBD	CU NIPDAU	Level-1-220C-UNLIM
TLC27L2MFKB	OBSOLETE	LCCC	FK	20		TBD	Call TI	Call TI
TLC27L2MJG	OBSOLETE	CDIP	JG	8		TBD	Call TI	Call TI
TLC27L2MJGB	OBSOLETE	CDIP	JG	8		TBD	Call TI	Call TI
TLC27L7CD	ACTIVE	SOIC	D	8	75	Green (RoHS & no Sb/Br)	CU NIPDAU	Level-1-260C-UNLIM
TLC27L7CDR	ACTIVE	SOIC	D	8	2500	Green (RoHS & no Sb/Br)	CU NIPDAU	Level-1-260C-UNLIM
TLC27L7CP	ACTIVE	PDIP	P	8	50	Pb-Free (RoHS)	CU NIPDAU	Level-NC-NC-NC
TLC27L7CPE4	ACTIVE	PDIP	P	8	50	Pb-Free (RoHS)	CU NIPDAU	Level-NC-NC-NC
TLC27L7CPSR	ACTIVE	SO	PS	8	2000	Pb-Free (RoHS)	CU NIPDAU	Level-2-260C-1YEAR/ Level-1-220C-UNLIM
TLC27L7ID	ACTIVE	SOIC	D	8	75	Green (RoHS & no Sb/Br)	CU NIPDAU	Level-1-260C-UNLIM
TLC27L7IDR	ACTIVE	SOIC	D	8	2500	Green (RoHS & no Sb/Br)	CU NIPDAU	Level-1-260C-UNLIM
TLC27L7IP	ACTIVE	PDIP	P	8	50	Pb-Free (RoHS)	CU NIPDAU	Level-NC-NC-NC
TLC27L7IPE4	ACTIVE	PDIP	P	8	50	Pb-Free (RoHS)	CU NIPDAU	Level-NC-NC-NC
TLC27L7MFKB	OBSOLETE	LCCC	FK	20		TBD	Call TI	Call TI
TLC27L7MJG	OBSOLETE	CDIP	JG	8		TBD	Call TI	Call TI
TLC27L7MJGB	OBSOLETE	CDIP	JG	8		TBD	Call TI	Call TI

<sup>(1)</sup> The marketing status values are defined as follows:  
**ACTIVE:** Product device recommended for new designs.