

Programmable voltage reference

Features

- Adjustable output voltage: 2.5 to 36 V
- Sink current capability: 1 to 100 mA
- Typical output impedance: 0.22 Ω
- 1% and 2% voltage precision
- Automotive temp. range - 40 °C to +125 °C

Applications

- Power supply
- Industrial
- Automotive

Description

The TL431 and TL432 are programmable shunt voltage references with guaranteed temperature stability over the entire operating temperature range. The device temperature range is extended for the automotive version from -40 °C up to +125 °C. The output voltage can be set to any value between 2.5 and 36 V with two external resistors. The TL431 and TL432 operate with a wide current range from 1 to 100 mA with a typical dynamic impedance of 0.22 Ω .

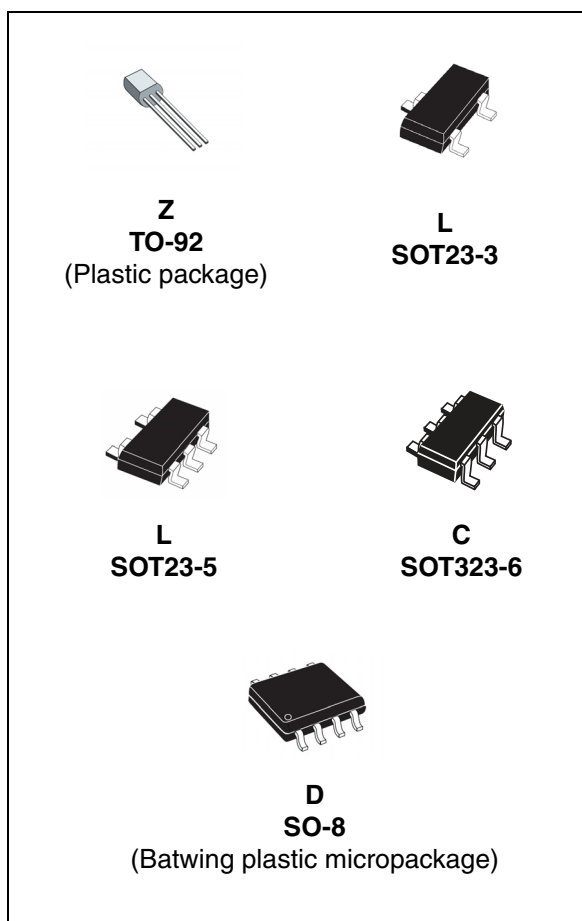

Contents

- 1 Schematic diagrams 3**
- 2 Absolute maximum ratings and operating conditions 4**
- 3 Electrical characteristics 5**
 - 3.1 Reference input voltage deviation over temperature range 7
- 4 Package information 11**
 - 4.1 SO-8 package information 12
 - 4.2 TO-92 ammpack and tape and reel package information 13
 - 4.3 TO-92 (bulk) package information 14
 - 4.4 SOT23-3 package information 15
 - 4.5 SOT23-5 package information 16
 - 4.6 SOT323-6 package information 17
- 5 Ordering information 18**
- 6 Revision history 20**

1 Schematic diagrams

Figure 1. TO-92 pin connections (top view)

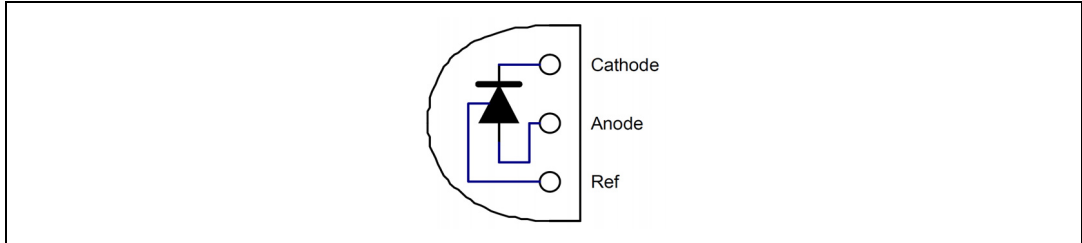

Figure 2. SO-8 batwing pin connections (top view)

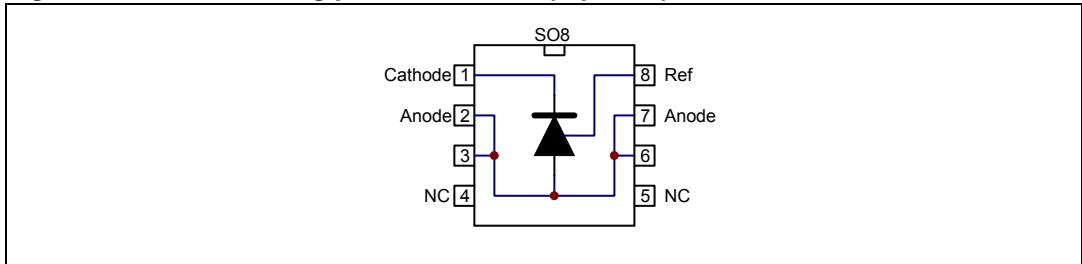

Figure 3. SOT23-5 and SOT23-3 pin connections (top view)

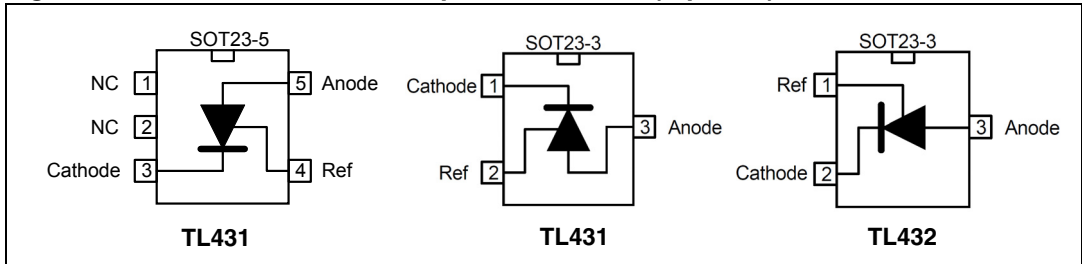

Figure 4. SOT323-6 pin connections (top view)

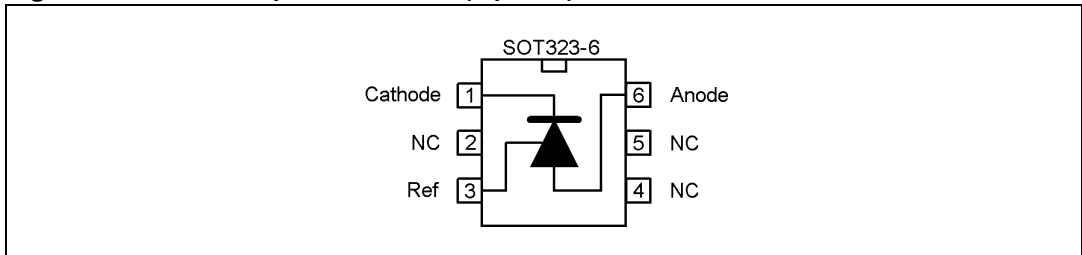
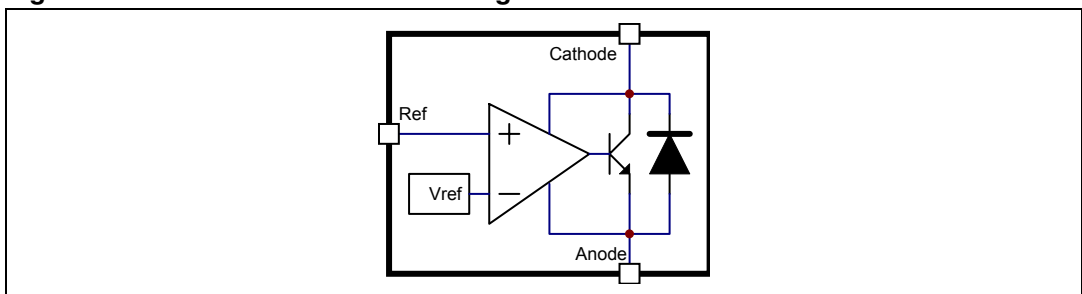

Figure 5. TL431 and TL432 block diagram



2 Absolute maximum ratings and operating conditions

Table 1. Absolute maximum ratings

Symbol	Parameter	Value	Unit
V_{KA}	Cathode to anode voltage	37	V
I_k	Continuous cathode current range	-100 to +150	mA
I_{ref}	Reference input current range	-0.05 to +10	mA
R_{thja}	Thermal resistance junction to ambient ⁽¹⁾		
	TO-92	200	°C/W
	SO-8 batwing	85	
	SOT23-3L	248	
	SOT23-5L	157	
SOT323-6L	221		
R_{thjc}	Thermal resistance junction to case ⁽¹⁾		
	SO-8 batwing	30	°C/W
	SOT23-3L	136	
	SOT23-5L	67	
	SOT323-6L	110	
T_{stg}	Storage temperature range	-65 to +150	°C
T_J	Junction temperature	150	°C
ESD	TL431IY, TL431AIY-T: HBM (human body model) ⁽²⁾	3000	V
	TL431-TL432: HBM (human body model)	2000	
	MM: machine model ⁽³⁾	200	
	CDM: charged device model ⁽⁴⁾	1500	

- Short-circuits can cause excessive heating. These values are typical.
- Human body model: a 100 pF capacitor is charged to the specified voltage, then discharged through a 1.5 kΩ resistor between two pins of the device. This is done for all couples of connected pin combinations while the other pins are floating.
- Machine model: a 200 pF capacitor is charged to the specified voltage, then discharged directly between two pins of the device with no external series resistor (internal resistor < 5 Ω). This is done for all couples of connected pin combinations while the other pins are floating.
- Charged device model: all pins and the package are charged together to the specified voltage and then discharged directly to the ground through only one pin. This is done for all pins.

Table 2. Operating conditions

Symbol	Parameter	Value	Unit
V_{KA}	Cathode to anode voltage	V_{ref} to 36	V
I_k	Cathode current	1 to 100	mA
T_{oper}	Operating free-air temperature range		°C
	TL431C/AC	0 to +70	
	TL431I/AI - TL432I/AI	-40 to +105	
	TL431IY/AIY	-40 to +125	

3 Electrical characteristics

Table 3. TL431C: 0° C to 70° C ($T_{amb} = 25^{\circ} \text{C}$ unless otherwise specified)

Symbol	Parameter	TL431C			TL431AC			Unit
		Min.	Typ.	Max.	Min.	Typ.	Max.	
V_{ref}	Reference input voltage $V_{KA} = V_{ref}$, $I_k = 10 \text{ mA}$, $T_{amb} = 25^{\circ} \text{C}$ $T_{min} \leq T_{amb} \leq T_{max}$	2.44 2.423	2.495	2.55 2.567	2.47 2.453	2.495	2.52 2.537	V
ΔV_{ref}	Reference input voltage deviation over temperature range ⁽¹⁾ $V_{KA} = V_{ref}$, $I_k = 10 \text{ mA}$, $T_{min} \leq T_{amb} \leq T_{max}$		3	17		3	15	mV
$\frac{\Delta V_{ref}}{\Delta V_{KA}}$	Ratio of change in reference input voltage to change in cathode to anode voltage $I_k = 10 \text{ mA}$ - $\Delta V_{KA} = 10 \text{ V}$ to V_{ref} $\Delta V_{KA} = 36 \text{ V}$ to 10 V	-2.7 -2	-1.4 -1		-2.7 -2	-1.4 -1		mV/V
I_{ref}	Reference input current $I_k = 10 \text{ mA}$, $R1 = 10 \text{ k}\Omega$, $R2 = \infty$ $T_{amb} = 25^{\circ} \text{C}$ $T_{min} \leq T_{amb} \leq T_{max}$		1.8	4 5.2		1.8	4 5.2	μA
ΔI_{ref}	Reference input current deviation over temperature range $I_k = 10 \text{ mA}$, $R1 = 10 \text{ k}\Omega$, $R2 = \infty$ $T_{min} \leq T_{amb} \leq T_{max}$		0.4	1.2		0.4	1.2	μA
I_{min}	Minimum cathode current for regulation $V_{KA} = V_{ref}$		0.5	1		0.5	0.6	mA
I_{off}	Off-state cathode current		2.6	1000		2.6	1000	nA
$ Z_{KA} $	Dynamic impedance ⁽²⁾ $V_{KA} = V_{ref}$, $\Delta I_k = 1$ to 100 mA , $f \leq 1 \text{ kHz}$		0.22	0.5		0.22	0.5	Ω

1. See definition of [Section 3.1: Reference input voltage deviation over temperature range](#).

2. The dynamic impedance is defined as $|Z_{KA}| = \frac{\Delta V_{KA}}{\Delta I_k}$

Table 4. TL431I/TL432I: -40° C to 105° C, T_{amb} = 25° C (unless otherwise specified)

Symbol	Parameter	TL431I/TL432I			TL431AI/TL432AI			Unit
		Min.	Typ.	Max.	Min.	Typ.	Max.	
V _{ref}	Reference input voltage V _{KA} = V _{ref} , I _k = 10 mA, T _{amb} = 25° C T _{min} ≤ T _{amb} ≤ T _{max}	2.44 2.41	2.495	2.55 2.58	2.47 2.44	2.495	2.52 2.55	V
ΔV _{ref}	Reference input voltage deviation over temperature range ⁽¹⁾ V _{KA} = V _{ref} , I _k = 10 mA, T _{min} ≤ T _{amb} ≤ T _{max}		7	30		7	30	mV
$\frac{\Delta V_{ref}}{\Delta V_{ka}}$	Ratio of change in reference input voltage to change in cathode to anode voltage I _k = 10 mA, ΔV _{KA} = 10 V to V _{ref} ΔV _{KA} = 36 V to 10 V	-2.7 -2	-1.4 -1		-2.7 -2	-1.4 -1		mV/V
I _{ref}	Reference input current I _k = 10 mA, R1 = 10 kΩ, R2 = ∞ T _{amb} = 25° C T _{min} ≤ T _{amb} ≤ T _{max}		1.8	4 6.5		1.8	4 6.5	μA
ΔI _{ref}	Reference input current deviation over temperature range I _k = 10 mA, R1 = 10 kΩ, R2 = ∞ T _{min} ≤ T _{amb} ≤ T _{max}		0.8	2.5		0.8	1.2	μA
I _{min}	Minimum cathode current for regulation V _{KA} = V _{ref}		0.5	1		0.5	0.7	mA
I _{off}	Off-state cathode current		2.6	1000		2.6	1000	nA
ZKA	Dynamic impedance ⁽²⁾ V _{KA} = V _{ref} , ΔI _k = 1 to 100 mA, f ≤ 1 kHz		0.22	0.5		0.22	0.5	Ω

1. See definition of [Section 3.1: Reference input voltage deviation over temperature range](#) below.

2. The dynamic impedance is defined as $|ZKA| = \frac{\Delta V_{KA}}{\Delta I_k}$

Table 5. TL431IY: -40° C to 125° C, T_{amb} = 25° C (unless otherwise specified)

Symbol	Parameter	TL431IY			TL431AIY			Unit
		Min.	Typ.	Max.	Min.	Typ.	Max.	
V _{ref}	Reference input voltage V _{KA} = V _{ref} , I _k = 10 mA T _{min} ≤ T _{amb} ≤ T _{max}	2.44 2.41	2.495	2.55 2.58	2.47 2.44	2.495	2.52 2.55	V
ΔV _{ref}	Reference input voltage deviation over temperature range ⁽¹⁾ V _{KA} = V _{ref} , I _k = 10 mA, T _{min} ≤ T _{amb} ≤ T _{max}		7	30		7	30	mV
$\frac{\Delta V_{ref}}{\Delta V_{ka}}$	Ratio of change in reference input voltage to change in cathode to anode voltage I _k = 10 mA, ΔV _{KA} = 10 V to V _{ref} I _k = 10 mA, ΔV _{KA} = 36 V to 10 V	-2.7 -2	-1.4 -1		-2.7 -2	-1.4 -1		mV/V
I _{ref}	Reference input current I _k = 10 mA, R1 = 10 kΩ, R2 = ∞ T _{min} ≤ T _{amb} ≤ T _{max}		1.8	4 6.5		1.8	4 6.5	μA
ΔI _{ref}	Reference input current deviation over temperature range I _k = 10 mA, R1 = 10 kΩ, R2 = ∞, T _{min} ≤ T _{amb} ≤ T _{max}		0.8	2.5		0.8	1.2	μA
I _{min}	Minimum cathode current for regulation V _{KA} = V _{ref}		0.5	1		0.5	0.6	mA
I _{off}	Off-state cathode current T _{min} ≤ T _{amb} ≤ T _{max}		2.6	1000 3000		2.6	1000 3000	nA
ZKA	Dynamic impedance ⁽²⁾ V _{KA} = V _{ref} , ΔI _k = 1 to 100 mA, F ≤ 1 kHz		0.22	0.5		0.22	0.5	Ω

1. See definition of [Section 3.1: Reference input voltage deviation over temperature range](#) below.

2. The dynamic impedance is defined as $|ZKA| = \frac{\Delta V_{KA}}{\Delta I_k}$

3.1 Reference input voltage deviation over temperature range

ΔV_{ref} is defined as the difference between the maximum and minimum values obtained over the full temperature range.

$$\Delta V_{ref} = V_{ref\ max} - V_{ref\ min}$$

Figure 6. Reference input voltage deviation over temperature range

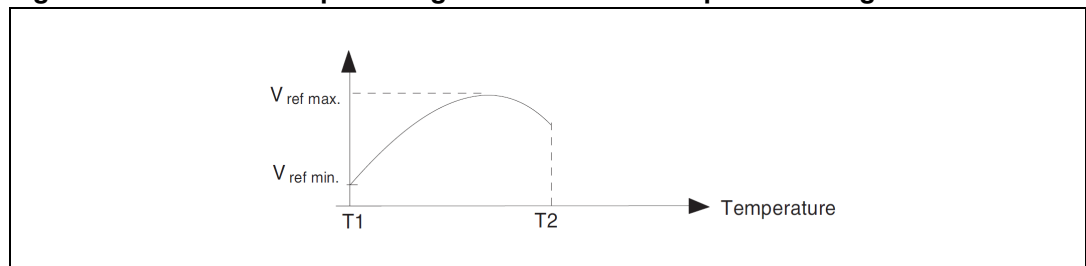

Figure 7. Test circuit for $V_{KA} = V_{ref}$

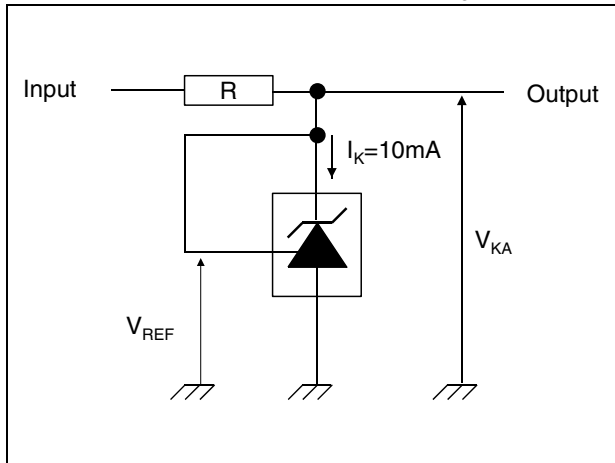

Figure 8. Test circuit for programming mode

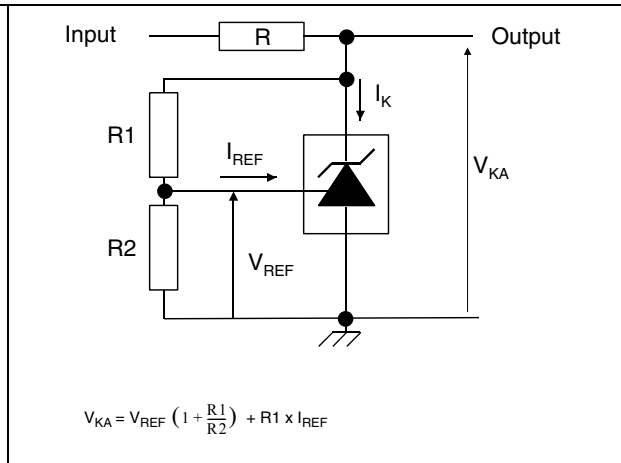

Figure 9. Test circuit for I_{off}

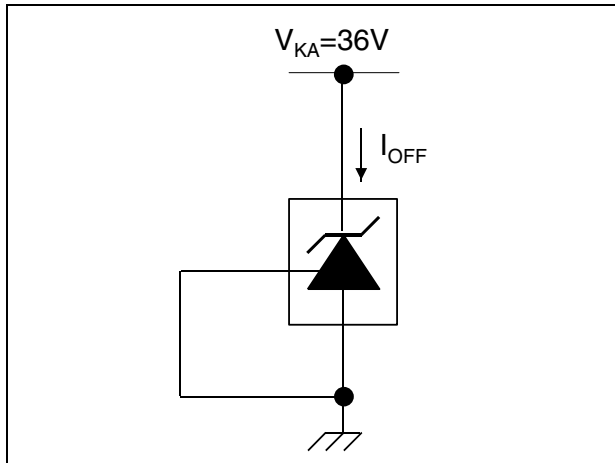

Figure 10. Test circuit for phase margin and voltage gain

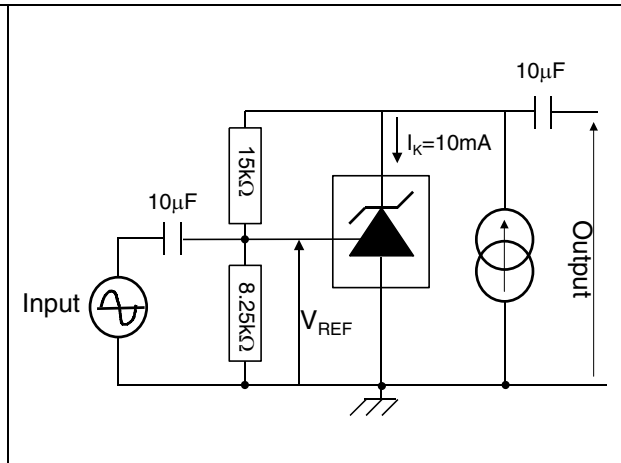

Figure 11. Test circuit for response time

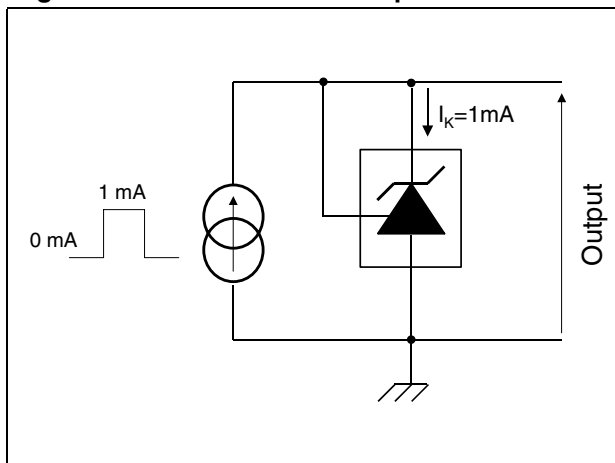

Figure 12. Reference voltage vs. temperature

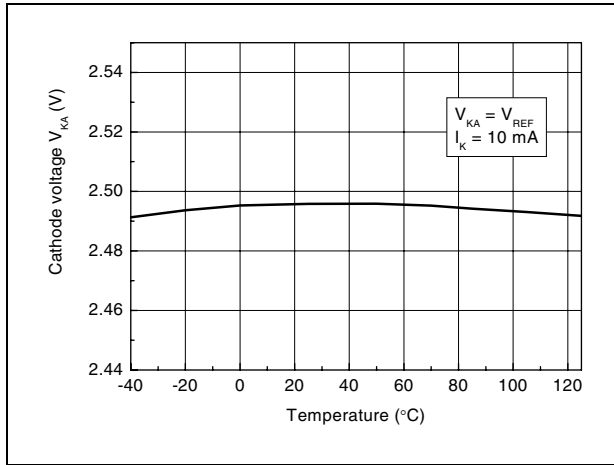

Figure 13. Reference voltage vs. cathode current

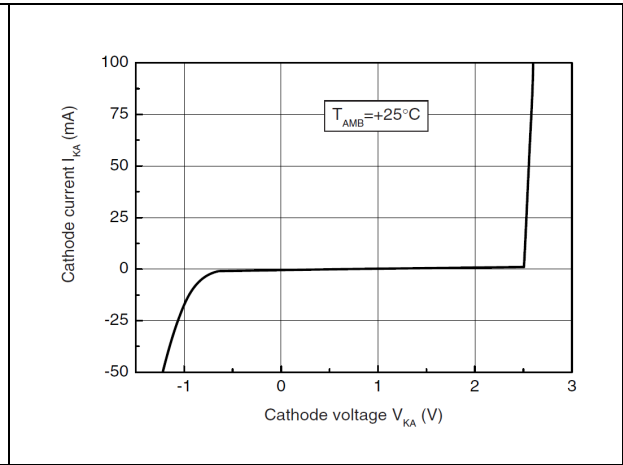

Figure 14. Zoom on reference voltage vs. cathode current

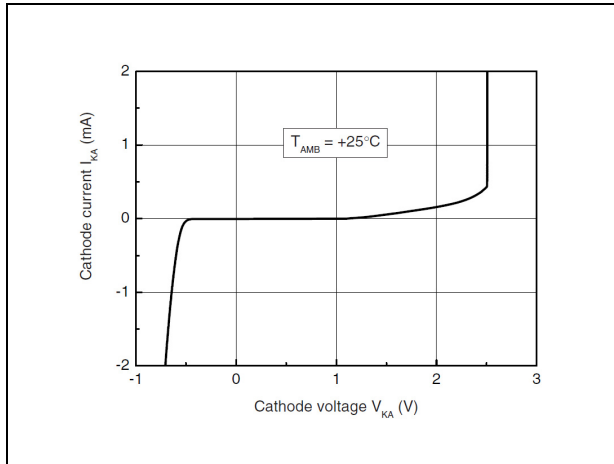

Figure 15. Reference current vs. temperature

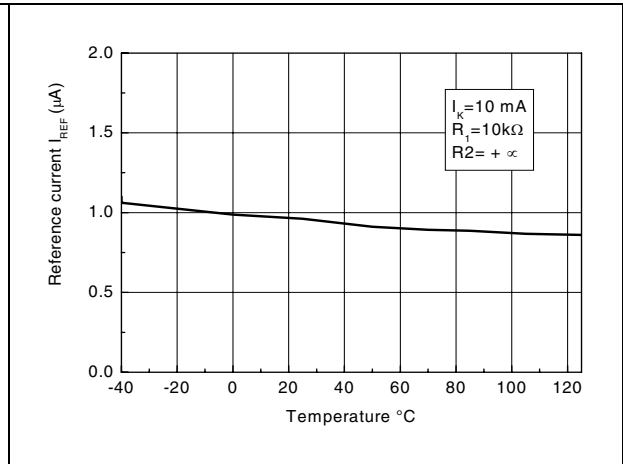

Figure 16. Off-state cathode current vs. temperature

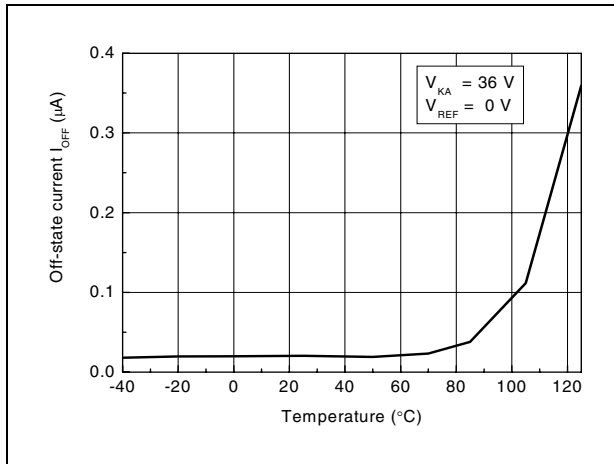

Figure 17. Ratio of change in V_REF to change in V_KA vs. temperature

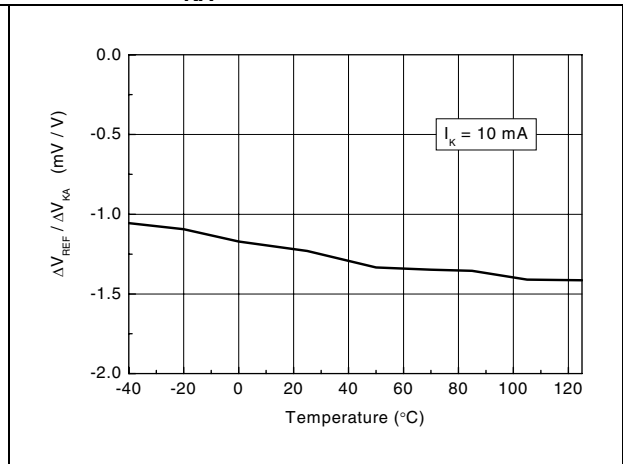

Figure 18. Static impedance R_{KA} vs. temperature

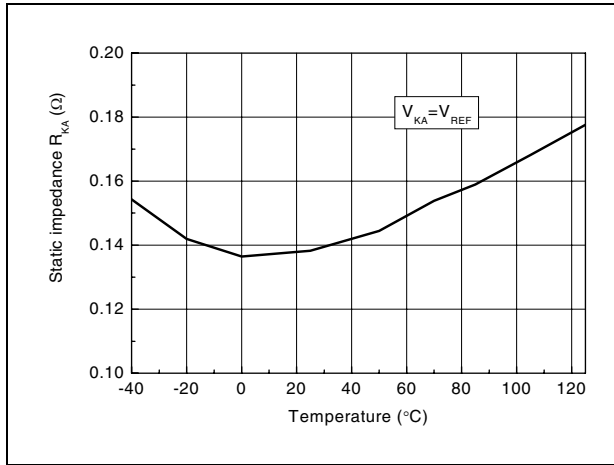

Figure 19. Minimum operating current vs. temperature

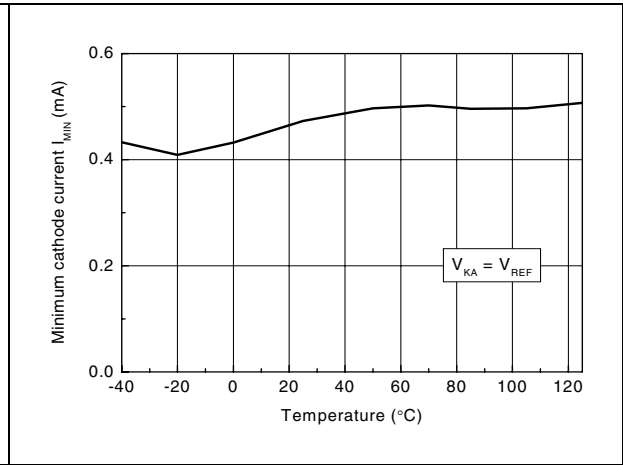

Figure 20. Gain and phase vs. frequency

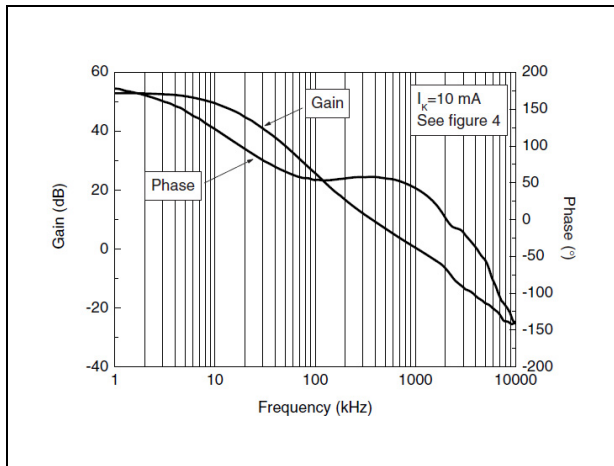

Figure 21. Stability behavior with capacitive loads

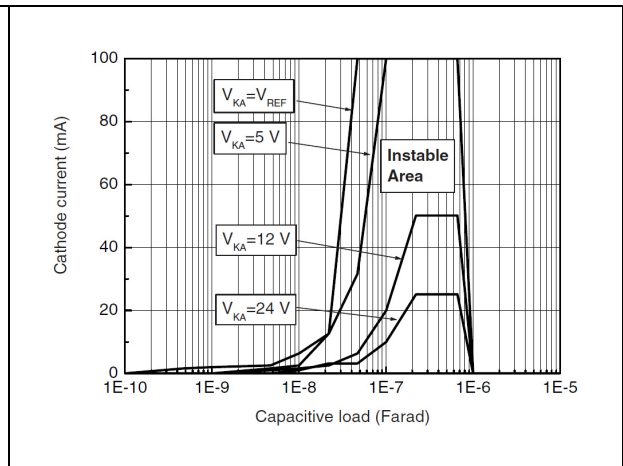

Figure 22. Maximum power dissipation

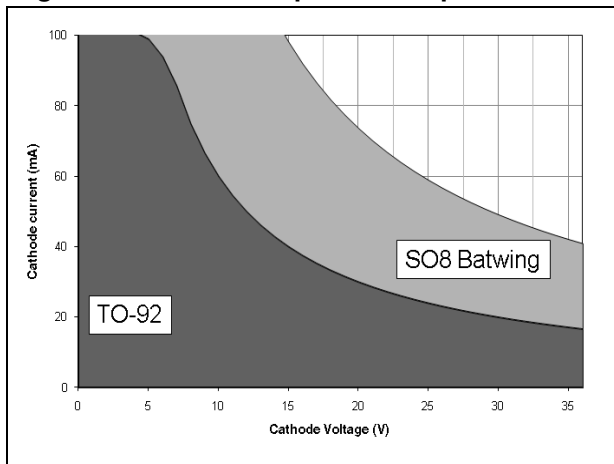
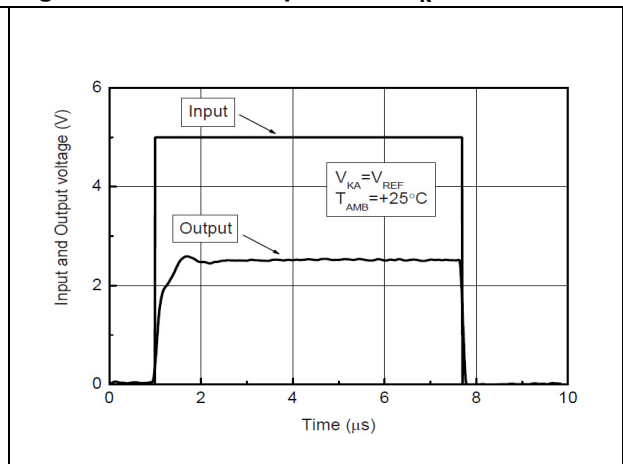

Figure 23. Pulse response for $I_K = 1$ mA



4 Package information

In order to meet environmental requirements, ST offers these devices in different grades of ECOPACK[®] packages, depending on their level of environmental compliance. ECOPACK[®] specifications, grade definitions and product status are available at: www.st.com. ECOPACK[®] is an ST trademark.

4.1 SO-8 package information

Figure 24. SO-8 package mechanical drawing

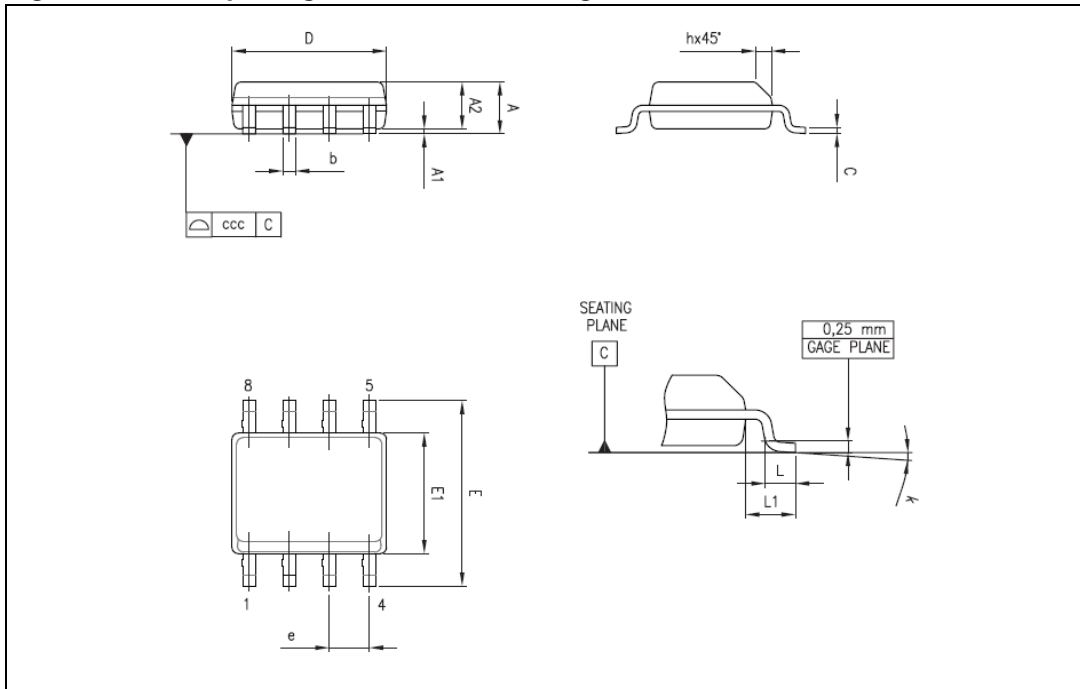

Table 6. SO-8 package mechanical data

Ref.	Dimensions					
	Millimeters			Inches		
	Min.	Typ.	Max.	Min.	Typ.	Max.
A			1.75			0.069
A1	0.10		0.25	0.004		0.010
A2	1.25			0.049		
b	0.28		0.48	0.011		0.019
c	0.17		0.23	0.007		0.010
D	4.80	4.90	5.00	0.189	0.193	0.197
E	5.80	6.00	6.20	0.228	0.236	0.244
E1	3.80	3.90	4.00	0.150	0.154	0.157
e		1.27			0.050	
h	0.25		0.50	0.010		0.020
L	0.40		1.27	0.016		0.050
L1		1.04			0.040	
k	0°		8°	0°		8°
ccc			0.10			0.004

4.2 TO-92 ammopack and tape and reel package information

Figure 25. TO-92 ammopack and tape and reel package mechanical drawing

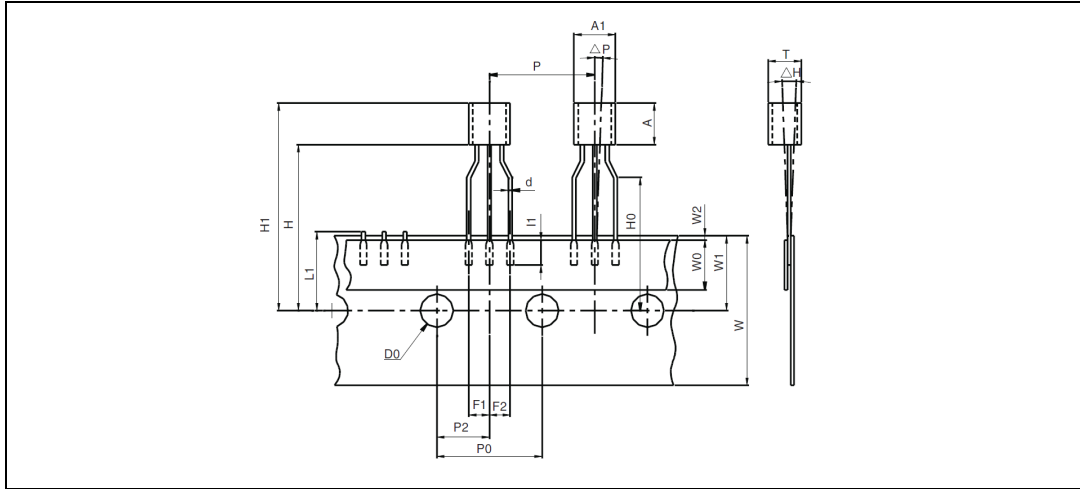

Table 7. TO-92 ammopack and tape and reel package mechanical data

Dim.	Millimeters			Inches		
	Min.	Typ.	Max.	Min.	Typ.	Max.
A1			5.0			0.197
A			5.0			0.197
T			4.0			0.157
d		0.45			0.018	
l1	2.5			0.098		
P	11.7	12.7	13.7	0.461	0.500	0.539
PO	12.4	12.7	13	0.488	0.500	0.512
P2	5.95	6.35	6.75	0.234	0.250	0.266
F1/F2	2.4	2.5	2.8	0.094	0.098	0.110
Δh	-1	0	1	-0.039	0	0.039
ΔP	-1	0	1	-0.039	0	0.039
W	17.5	18.0	19.0	0.689	0.709	0.748
W0	5.7	6	6.3	0.224	0.236	0.248
W1	8.5	9	9.75	0.335	0.354	0.384
W2			0.5			0.020
H			20			0.787
H0	15.5	16	16.5	0.610	0.630	0.650
H1			25			0.984
DO	3.8	4.0	4.2	0.150	0.157	0.165
L1			11			0.433

4.3 TO-92 (bulk) package information

Figure 26. TO-92 bulk package mechanical drawing

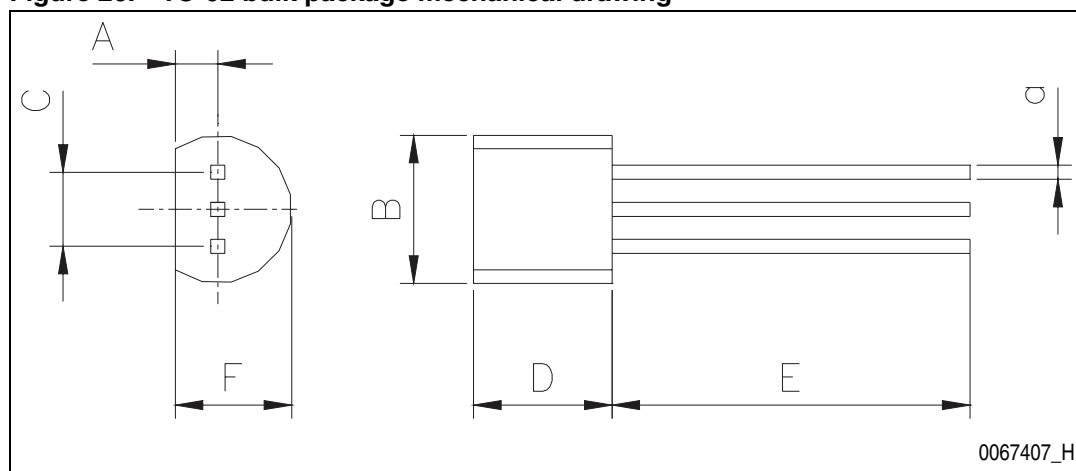

Table 8. TO-92 bulk package mechanical data

Dim.	Millimeters			Inches		
	Min.	Typ.	Max.	Min.	Typ.	Max.
A		1.35			0.053	
B			4.70			0.185
C		2.54			0.100	
D	4.40			0.173		
E	12.70			0.500		
F			3.70			0.146
a			0.5			0.019

4.4 SOT23-3 package information

Figure 27. SOT23-3 package mechanical drawing

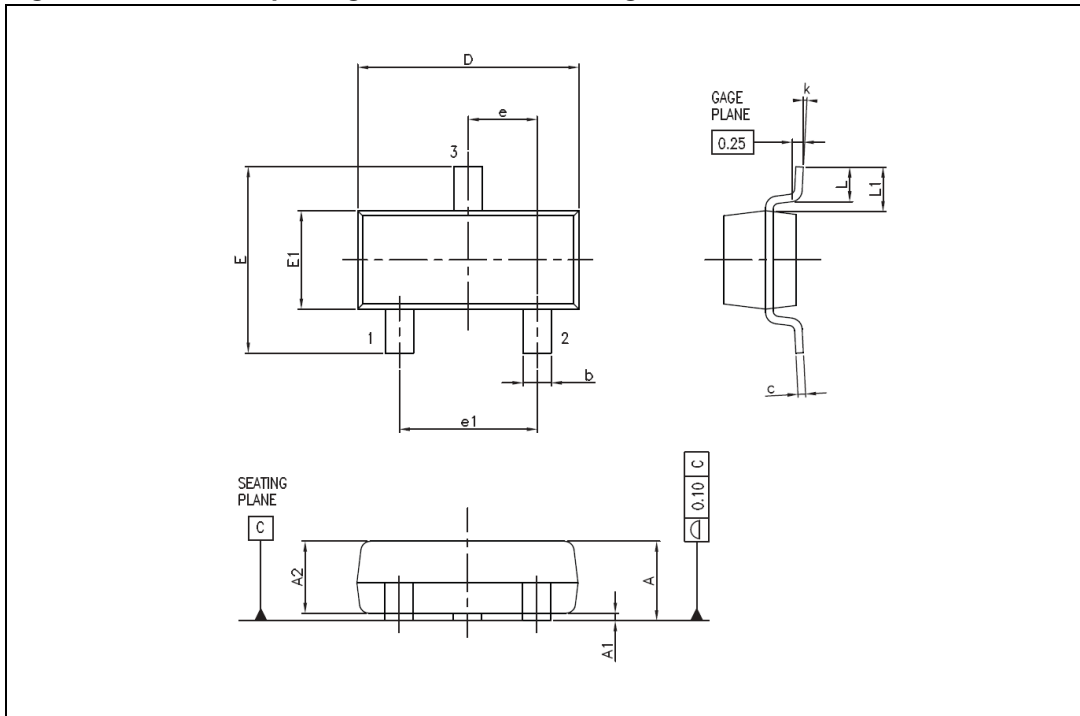

Table 9. SOT23-3 package mechanical data

Dimensions						
Ref.	Millimeters			Inches		
	Min.	Typ.	Max.	Min.	Typ.	Max.
A	0.89		1.12	0.035		0.044
A1	0.01		0.10	0.0004		0.004
A2	0.88	0.95	1.02	0.035	0.037	0.040
b	0.30		0.50	0.012		0.020
c	0.08		0.20	0.003		0.008
D	2.80	2.90	3.04	0.110	0.114	0.120
E	2.10		2.64	0.083		0.104
E1	1.20	1.30	1.40	0.047	0.051	0.055
e		0.95			0.037	
e1		1.90			0.075	
L	0.40	0.50	0.60	0.016	0.020	0.024
L1		0.54			0.021	
k	0d		8d			

4.5 SOT23-5 package information

Figure 28. SOT23-5 package mechanical drawing

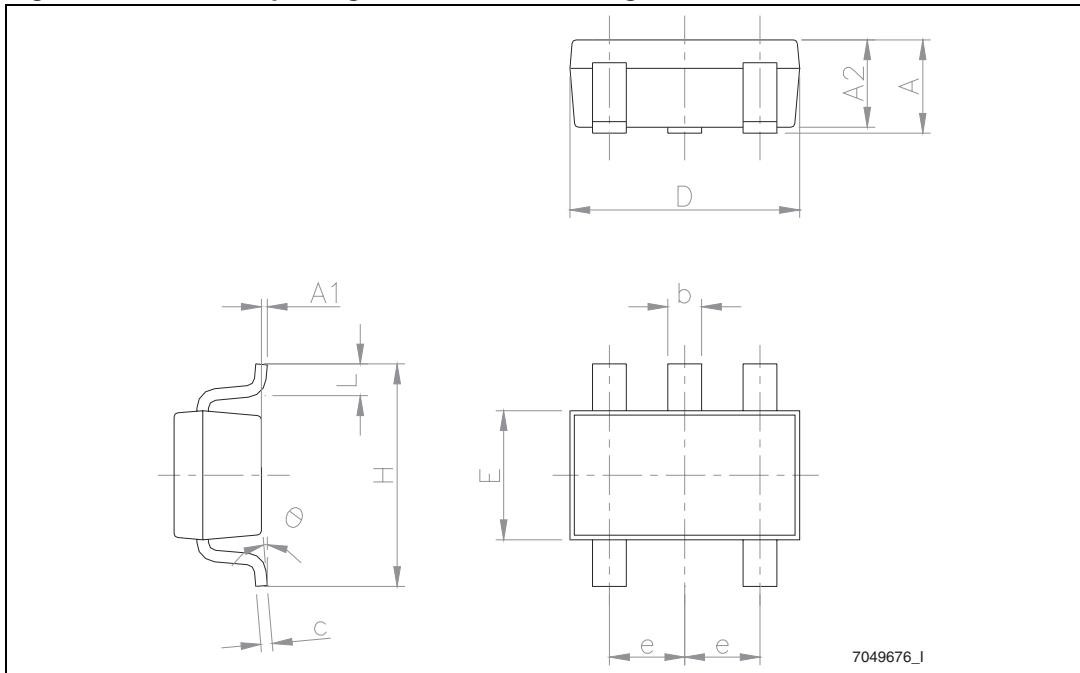
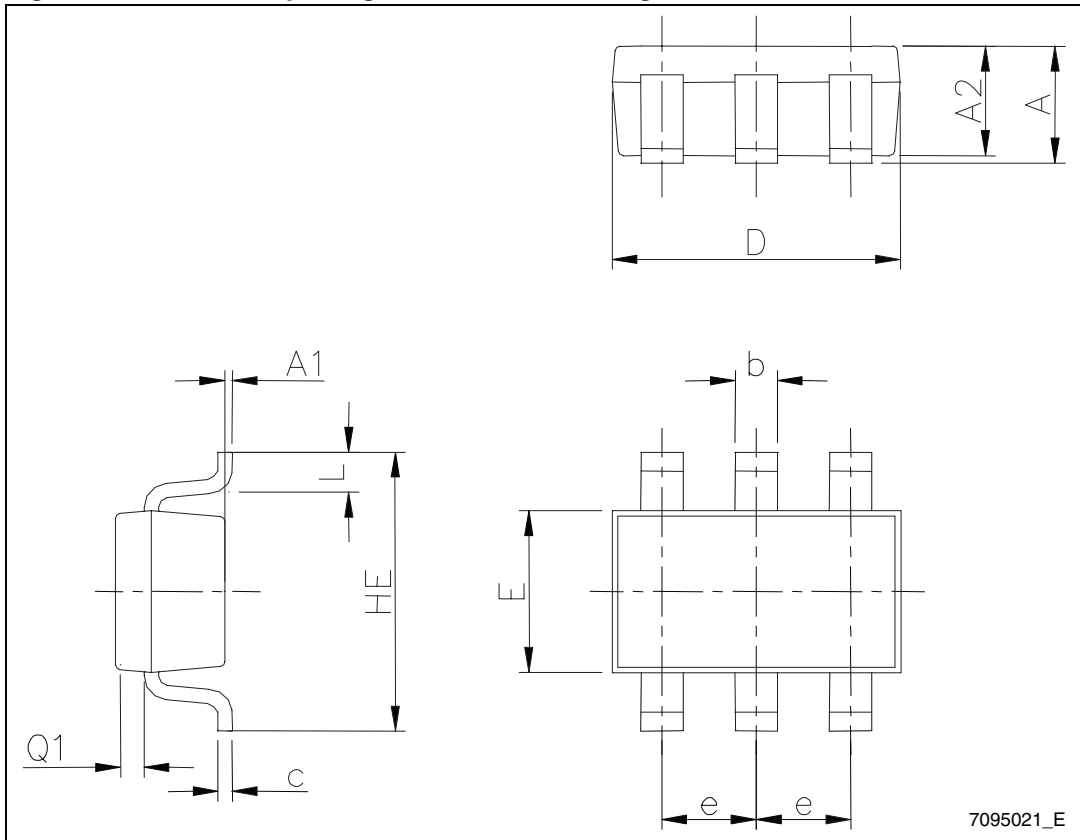

Table 10. SOT23-5 package mechanical data

Ref.	Dimensions					
	Millimeters			Inches		
	Min.	Typ.	Max.	Min.	Typ.	Max.
A	0.90		1.45	0.035		0.057
A1			0.15			0.006
A2	0.90		1.30	0.035		0.051
b	0.35		0.50	0.014		0.020
c	0.09		0.20	0.004		0.008
D	2.80		3.05	0.110		0.120
E	1.50		1.75	0.059		0.069
e		0.95			0.037	
H	2.60		3.00	0.102		0.118
L	0.10		0.60	0.004		0.024
θ	0 degrees		10 degrees			

4.6 SOT323-6 package information

Figure 29. SOT323-6 package mechanical drawing



7095021_E

Table 11. SOT323-6 package mechanical data

Ref.	Dimensions					
	Millimeters			Inches		
	Min.	Typ.	Max.	Min.	Typ.	Max.
A	0.80		1.10	0.031		0.043
A1	0		0.10			0.004
A2	0.80		1.00	0.031		0.039
b	0.15		0.30	0.006		0.012
c	0.10		0.18	0.004		0.007
D	1.80		2.20	0.071		0.087
E	1.15		1.35	0.045		0.053
e		0.65			0.026	
HE	1.80		2.40	0.071		0.094
L	0.10		0.40	0.004		0.016
Q1	0.10		0.40	0.004		0.016

5 Ordering information

Table 12. Order codes

Order code	Accuracy (%)	Temperature range	Package	Packing	Marking	
TL431CD TL431CDT	2	0°C to +70°C	SO-8	Tube or Tape and reel	431C	
TL431ACD TL431ACDT	1				431AC	
TL431CZ TL431CZT TL431CZ-AP	2		TO-92	Bulk or Tape or Ammopack	TL431C	
TL431ACZ TL431ACZT TL431ACZ-AP	1				TL431AC	
TL431CL3T	2		-40°C to + 105°C	SOT23-3	Tape	L19
TL431ACL3T	1			SOT23-5		L18
TL431CL5T	2					SOT323-6
TL431ACL5T	1			L18		
TL431CCT	2			SOT323-6		31C
TL431ACCT	1					31C
TL431ID TL431IDT	2	SO-8		Tube or tape and reel		431I
TL431AID TL431AIDT	1					431AI
TL431IZ TL431IZT TL431IZ-AP	2	TO-92		Bulk or Tape or Ammopack		TL431I
TL431AIZ TL431AIZT TL431AIZ-AP	1					TL431AI
TL431IL3T	2	-40°C to + 105°C	SOT23-3	Tape	L17	
TL431AIL3T	1		SOT23-3		L16	
TL432IL3T	2				SOT23-5	32I
TL432AIL3T	1		SOT323-6			32AI
TL431IL5T	2				SOT323-6	L17
TL431AIL5T	1		L16			
TL431ICT	2		SOT323-6		31I	
TL431AICT	1				31I	

Table 12. Order codes (continued)

Order code	Accuracy (%)	Temperature range	Package	Packing	Marking
TL431IYD ⁽¹⁾ TL431IYDT ⁽¹⁾	2	-40°C to + 125°C	SO-8 (Automotive grade level)	Tube or tape and reel	431IY
TL431AIYD ⁽¹⁾ TL431AIYDT ⁽¹⁾	1				431AIY

1. Qualification and characterization according to AEC Q100 and Q003 or equivalent, advanced screening according to AEC Q001 & Q 002 or equivalent.

6 Revision history

Table 13. Document revision history

Date	Revision	Changes
01-Mar-2002	1	Initial release.
01-Nov-2005	2	PPAP references inserted in order codes table on cover page.
13-Dec-2006	3	Corrected TO-92 package information.
08-Jun-2007	4	Specified that SO-8 package is batwing package. In electrical characteristics tables, moved negative values from max column to min column. Corrected captions of Figure 7 and of Figure 18 . Added footnote to Table 8: TO-92 bulk package mechanical data .
25-Feb-2008	5	Corrected SO-8 package mechanical data. Corrected footnote for automotive grade order codes in order code table. Corrected packing information for TO-92 devices in order code table.
04-Jun-2009	6	Changed I_{MIN} to 0.6 mA in Table 3 and Table 4 . Increased temperature range to 125°C in temperature curves. Added Table 5 , dedicated to automotive version. Increased high temperature for automotive range up to +125°C in Table 5 and in Table 12: Order codes . Inserted accuracy column in Table 12 .
09-Jun-2009	7	Corrected minor error in package column in Table 12 .
14-Mar-2011	8	Added Figure 3 on page 3 , Section 4.4 on page 15 and Section 4.5 on page 16 .
07-Oct-2011	9	Added new package mechanical data Table 11 on page 17 and Figure 29 on page 17 . Updated Table 12 on page 18 .
17-Nov-2011	10	Added new part number TL432, new order code Table 12 on page 18 and pin connection for TL432 Figure 3 on page 3 .

Please Read Carefully:

Information in this document is provided solely in connection with ST products. STMicroelectronics NV and its subsidiaries ("ST") reserve the right to make changes, corrections, modifications or improvements, to this document, and the products and services described herein at any time, without notice.

All ST products are sold pursuant to ST's terms and conditions of sale.

Purchasers are solely responsible for the choice, selection and use of the ST products and services described herein, and ST assumes no liability whatsoever relating to the choice, selection or use of the ST products and services described herein.

No license, express or implied, by estoppel or otherwise, to any intellectual property rights is granted under this document. If any part of this document refers to any third party products or services it shall not be deemed a license grant by ST for the use of such third party products or services, or any intellectual property contained therein or considered as a warranty covering the use in any manner whatsoever of such third party products or services or any intellectual property contained therein.

UNLESS OTHERWISE SET FORTH IN ST'S TERMS AND CONDITIONS OF SALE ST DISCLAIMS ANY EXPRESS OR IMPLIED WARRANTY WITH RESPECT TO THE USE AND/OR SALE OF ST PRODUCTS INCLUDING WITHOUT LIMITATION IMPLIED WARRANTIES OF MERCHANTABILITY, FITNESS FOR A PARTICULAR PURPOSE (AND THEIR EQUIVALENTS UNDER THE LAWS OF ANY JURISDICTION), OR INFRINGEMENT OF ANY PATENT, COPYRIGHT OR OTHER INTELLECTUAL PROPERTY RIGHT.

UNLESS EXPRESSLY APPROVED IN WRITING BY TWO AUTHORIZED ST REPRESENTATIVES, ST PRODUCTS ARE NOT RECOMMENDED, AUTHORIZED OR WARRANTED FOR USE IN MILITARY, AIR CRAFT, SPACE, LIFE SAVING, OR LIFE SUSTAINING APPLICATIONS, NOR IN PRODUCTS OR SYSTEMS WHERE FAILURE OR MALFUNCTION MAY RESULT IN PERSONAL INJURY, DEATH, OR SEVERE PROPERTY OR ENVIRONMENTAL DAMAGE. ST PRODUCTS WHICH ARE NOT SPECIFIED AS "AUTOMOTIVE GRADE" MAY ONLY BE USED IN AUTOMOTIVE APPLICATIONS AT USER'S OWN RISK.

Resale of ST products with provisions different from the statements and/or technical features set forth in this document shall immediately void any warranty granted by ST for the ST product or service described herein and shall not create or extend in any manner whatsoever, any liability of ST.

ST and the ST logo are trademarks or registered trademarks of ST in various countries.

Information in this document supersedes and replaces all information previously supplied.

The ST logo is a registered trademark of STMicroelectronics. All other names are the property of their respective owners.

© 2011 STMicroelectronics - All rights reserved

STMicroelectronics group of companies

Australia - Belgium - Brazil - Canada - China - Czech Republic - Finland - France - Germany - Hong Kong - India - Israel - Italy - Japan - Malaysia - Malta - Morocco - Philippines - Singapore - Spain - Sweden - Switzerland - United Kingdom - United States of America

www.st.com