

Complementary power transistors

Features

- Low collector-emitter saturation voltage
- Complementary NPN - PNP transistors

Applications

- General purpose
- Audio amplifier

Description

The devices are manufactured in planar technology with “base island” layout. The resulting transistors show exceptional high gain performance coupled with very low saturation voltage.

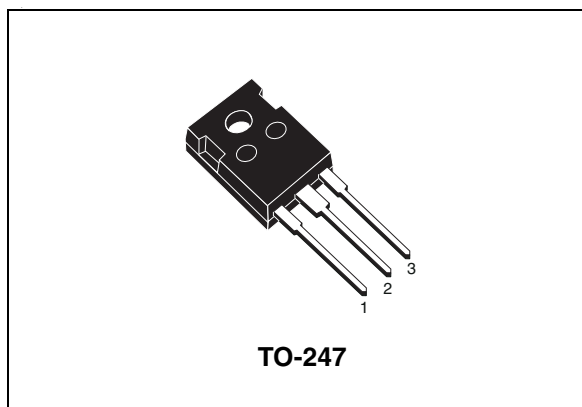

Figure 1. Internal schematic diagrams

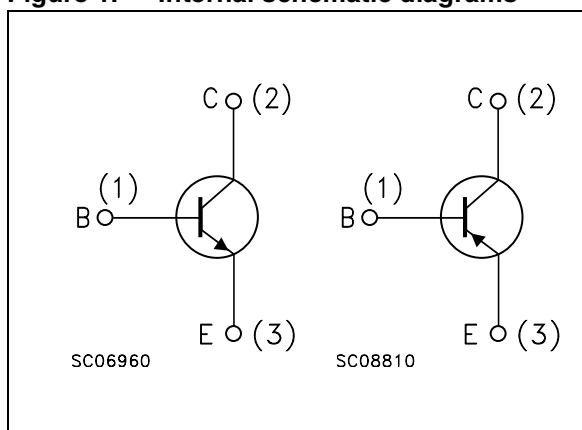

Table 1. Device summary

Order code	Marking	Package	Packaging
TIP35C	TIP35C	TO-247	Tube
TIP36C	TIP36C		

1 Electrical ratings

Table 2. Absolute maximum ratings

Symbol	Parameter		Value	Unit
		NPN	TIP35C	
		PNP	TIP36C	
V_{CBO}	Collector-base voltage ($I_E = 0$)		100	V
V_{CEO}	Collector-emitter voltage ($I_B = 0$)		100	V
V_{EBO}	Emitter-base voltage ($I_C = 0$)		5	V
I_C	Collector current		25	A
I_{CM}	Collector peak current ($t_p < 5$ ms)		50	A
I_B	Base current		5	A
P_{tot}	Total dissipation at $T_{case} = 25$ °C		125	W
T_{stg}	Storage temperature		-65 to 150	°C
T_J	Max. operating junction temperature		150	°C

For PNP type voltage and current values are negative.

Table 3. Thermal data

Symbol	Parameter		Value	Unit
$R_{thj-case}$	Thermal resistance junction-case	max	1	°C/W

2 Electrical characteristics

($T_{\text{case}} = 25\text{ °C}$; unless otherwise specified)

Table 4. Electrical characteristics

Symbol	Parameter	Test conditions	Min.	Typ.	Max.	Unit
I_{CEO}	Collector cut-off current ($I_{\text{B}} = 0$)	$V_{\text{CE}} = 60\text{ V}$			1	mA
I_{EBO}	Emitter cut-off current ($I_{\text{C}} = 0$)	$V_{\text{EB}} = 5\text{ V}$			1	mA
I_{CES}	Collector cut-off current ($V_{\text{BE}} = 0$)	$V_{\text{CE}} = 100\text{ V}$			0.7	mA
$V_{\text{CEO(sus)}}^{(1)}$	Collector-emitter sustaining voltage ($I_{\text{B}} = 0$)	$I_{\text{C}} = 30\text{ mA}$	100			V
$V_{\text{CE(sat)}}^{(1)}$	Collector-emitter saturation voltage	$I_{\text{C}} = 15\text{ A}$			1.8	V
		$I_{\text{C}} = 25\text{ A}$			4	V
$V_{\text{BE(on)}}^{(1)}$	Base-emitter voltage	$I_{\text{C}} = 15\text{ A}$			2	V
		$I_{\text{C}} = 25\text{ A}$			4	V
$h_{\text{FE}}^{(1)}$	DC current gain	$I_{\text{C}} = 1.5\text{ A}$		25		
		$I_{\text{C}} = 15\text{ A}$		10		50
f_{T}	Transition frequency	$I_{\text{C}} = 1\text{ A}$ $f = 1\text{ MHz}$		3		MHz

1. Pulsed duration = 300 ms, duty cycle $\geq 1.5\%$.

For PNP type voltage and current are negative.

3 Package mechanical data

In order to meet environmental requirements, ST offers these devices in ECOPACK® packages. These packages have a Lead-free second level interconnect . The category of second level interconnect is marked on the package and on the inner box label, in compliance with JEDEC Standard JESD97. The maximum ratings related to soldering conditions are also marked on the inner box label. ECOPACK is an ST trademark.

TO-247 Mechanical data

Dim.	mm.		
	Min.	Typ	Max.
A	4.85		5.15
A1	2.20		2.60
b	1.0		1.40
b1	2.0		2.40
b2	3.0		3.40
c	0.40		0.80
D	19.85		20.15
E	15.45		15.75
e		5.45	
L	14.20		14.80
L1	3.70		4.30
L2		18.50	
øP	3.55		3.65
øR	4.50		5.50
S		5.50	

