

HIGH-SPEED, LOW-NOISE, FULLY-DIFFERENTIAL I/O AMPLIFIERS

 Check for Samples: [THS4130](#), [THS4131](#)

FEATURES

- **High Performance**
 - 150 MHz, –3 dB Bandwidth ($V_{CC} = \pm 15\text{ V}$)
 - 51 V/ μs Slew Rate
 - –100 dB Third Harmonic Distortion at 250 kHz
- **Low Noise**
 - 1.3 nV/ $\sqrt{\text{Hz}}$ Input-Referred Noise
- **Differential-Input/Differential-Output**
 - Balanced Outputs Reject Common-Mode Noise
 - Reduced Second-Harmonic Distortion Due to Differential Output
- **Wide Power-Supply Range**
 - $V_{CC} = 5\text{ V}$ Single Supply to $\pm 15\text{ V}$ Dual Supply
- $I_{CC(SD)} = 860\ \mu\text{A}$ in Shutdown Mode (THS4130)

APPLICATIONS

- Single-Ended To Differential Conversion
- Differential ADC Driver
- Differential Antialiasing
- Differential Transmitter And Receiver
- Output Level Shifter

DESCRIPTION

The THS413x is one in a family of fully-differential input/differential output devices fabricated using Texas Instruments' state-of-the-art BiCom1 complementary bipolar process.

The THS413x is made of a true fully-differential signal path from input to output. This design leads to an excellent common-mode noise rejection and improved total harmonic distortion.

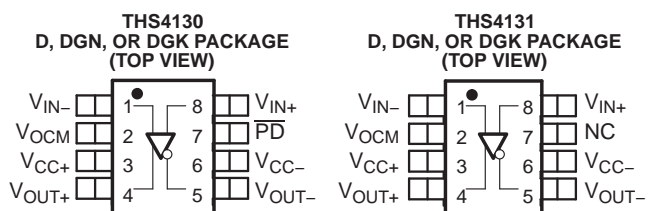

HIGH-SPEED DIFFERENTIAL I/O FAMILY

DEVICE	NUMBER OF CHANNELS	SHUTDOWN
THS4130	1	X
THS4131	1	–

RELATED DEVICES

DEVICE	DESCRIPTION
THS412x	100 MHz, 43 V/ μs , 3.7 nV/ $\sqrt{\text{Hz}}$
THS414x	160 MHz, 450 V/ μs , 6.5 nV/ $\sqrt{\text{Hz}}$
THS415x	180 MHz, 850 V/ μs , 9 nV/ $\sqrt{\text{Hz}}$

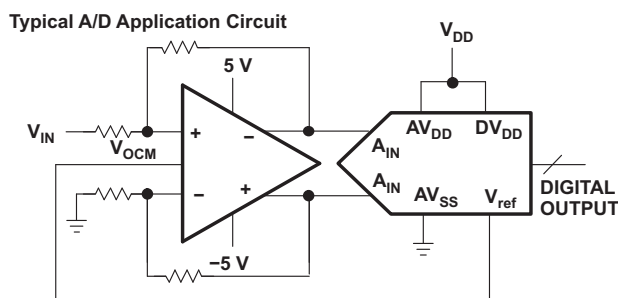

TOTAL HARMONIC DISTORTION vs FREQUENCY

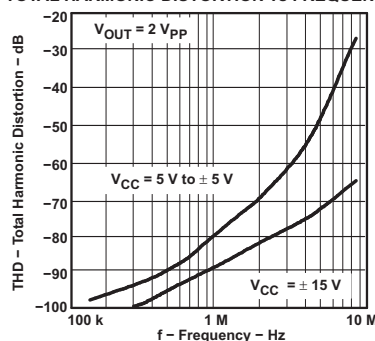

Please be aware that an important notice concerning availability, standard warranty, and use in critical applications of Texas Instruments semiconductor products and disclaimers thereto appears at the end of this data sheet.

PowerPAD is a trademark of Texas Instruments.
 All other trademarks are the property of their respective owners.



This integrated circuit can be damaged by ESD. Texas Instruments recommends that all integrated circuits be handled with appropriate precautions. Failure to observe proper handling and installation procedures can cause damage.

ESD damage can range from subtle performance degradation to complete device failure. Precision integrated circuits may be more susceptible to damage because very small parametric changes could cause the device not to meet its published specifications.

AVAILABLE OPTIONS⁽¹⁾

T _A	PACKAGED DEVICES					EVALUATION MODULES
	SMALL OUTLINE (D)	MSOP PowerPAD™		MSOP		
		(DGN)	SYMBOL	(DGK)	SYMBOL	
0°C to +70°C	THS4130CD	THS4130CDGN	AOB	THS4130CDGK	ATP	THS4130EVM
	THS4131CD	THS4131CDGN	AOD	THS4131CDGK	ATQ	THS4131EVM
–40°C to +85°C	THS4130ID	THS4130IDGN	AOC	THS4130IDGK	ASO	—
	THS4131ID	THS4131IDGN	AOE	THS4131IDGK	ASP	—

(1) For the most current package and ordering information, see the Package Option Addendum at the end of this document, or see the TI Web site at www.ti.com.

ABSOLUTE MAXIMUM RATINGS⁽¹⁾

Over operating free-air temperature range, unless otherwise noted.

		UNIT	
V _{CC-} to V _{CC+}	Supply voltage	±33 V	
V _I	Input voltage	±V _{CC}	
I _O ⁽²⁾	Output current	150 mA	
V _{ID}	Differential input voltage	±6 V	
	Continuous total power dissipation	See Dissipation Rating table	
T _J ⁽³⁾	Maximum junction temperature	+150°C	
T _J ⁽⁴⁾	Maximum junction temperature, continuous operation, long-term reliability	+125°C	
T _A	Operating free-air temperature	C-suffix	0°C to +70°C
		I-suffix	–40°C to +85°C
T _{STG}	Storage temperature	–65°C to +150°C	
	ESD ratings:	HBM	2500 V
		CDM	1500 V
		MM	200 V

- Stresses beyond those listed under absolute maximum ratings may cause permanent damage to the device. These are stress ratings only, and functional operation of the device at these or any other conditions beyond those indicated under recommended operating conditions is not implied. Exposure to absolute-maximum-rated conditions for extended periods may affect device reliability.
- The THS413x may incorporate a PowerPAD on the underside of the chip. This acts as a heatsink and must be connected to a thermally dissipative plane for proper power dissipation. Failure to do so may result in exceeding the maximum junction temperature which could permanently damage the device. See TI technical briefs [SLMA002](#) and [SLMA004](#) for more information about using the PowerPAD thermally-enhanced package.
- The absolute maximum temperature under any condition is limited by the constraints of the silicon process.
- The maximum junction temperature for continuous operation is limited by package constraints. Operation above this temperature may result in reduced reliability and/or lifetime of the device.

DISSIPATION RATING TABLE

PACKAGE	θ _{JA} ⁽¹⁾ (°C/W)	θ _{JC} (°C/W)	POWER RATING ⁽²⁾	
			T _A = +25°C	T _A = +85°C
D	97.5	38.3	1.02 W	410 mW
DGN	58.4	4.7	1.71 W	685 mW
DGK	134	72	750 mW	300 mW

- This data was taken using the JEDEC standard High-K test PCB.
- Power rating is determined with a junction temperature of +125°C. This is the point where distortion starts to substantially increase. Thermal management of the final PCB should strive to keep the junction temperature at or below +125°C for best performance and long-term reliability.

RECOMMENDED OPERATING CONDITIONS

		MIN	TYP	MAX	UNIT
Supply voltage, V_{CC+} to V_{CC-}	Dual supply	± 2.5		± 15	V
	Single supply	5		30	
Operating free-air temperature, T_A	C-suffix	0		+70	°C
	I-suffix	-40		+85	

ELECTRICAL CHARACTERISTICS⁽¹⁾

$V_{CC} = \pm 5$ V, $R_L = 800\Omega$, and $T_A = +25^\circ\text{C}$, unless otherwise noted.

PARAMETER		TEST CONDITIONS		MIN	TYP	MAX	UNIT			
DYNAMIC PERFORMANCE										
BW	Small-signal bandwidth (-3 dB), single-ended input, differential output, $V_I = 63$ mV _{PP}	$V_{CC} = 5$	Gain = 1, $R_f = 390\Omega$		125		MHz			
		$V_{CC} = \pm 5$	Gain = 1, $R_f = 390\Omega$		135					
		$V_{CC} = \pm 15$	Gain = 1, $R_f = 390\Omega$		150					
	Small-signal bandwidth (-3 dB), single-ended input, differential output, $V_I = 63$ mV _{PP}	$V_{CC} = 5$	Gain = 2, $R_f = 750\Omega$		80					
		$V_{CC} = \pm 5$	Gain = 2, $R_f = 750\Omega$		85					
		$V_{CC} = \pm 15$	Gain = 2, $R_f = 750\Omega$		90					
SR	Slew rate ⁽²⁾	Gain = 1			52		V/ μ s			
t_s	Settling time to 0.1%	Step voltage = 2 V, gain = 1			78		ns			
	Settling time to 0.01%				213		ns			
DISTORTION PERFORMANCE										
THD	Total harmonic distortion, differential input, differential output, gain = 1, $R_f = 390\Omega$, $R_L = 800\Omega$, $V_O = 2$ V _{PP}	$V_{CC} = 5$	$f = 250$ kHz		-95		dBc			
			$f = 1$ MHz		-81					
		$V_{CC} = \pm 5$	$f = 250$ kHz		-96					
			$f = 1$ MHz		-80					
		$V_{CC} = \pm 15$	$f = 250$ kHz		-97					
			$f = 1$ MHz		-80					
	$V_O = 4$ V _{PP}	$V_{CC} = \pm 5$	$f = 250$ kHz		-91					
			$f = 1$ MHz		-75					
		$V_{CC} = \pm 15$	$f = 250$ kHz		-91					
			$f = 1$ MHz		-75					
		SFDR	Spurious-free dynamic range, differential input, differential output, gain = 1, $R_f = 390\Omega$, $R_L = 800\Omega$, $f = 250$ kHz	$V_O = 2$ V _{PP}	$V_{CC} = \pm 2.5$			97		dB
					$V_{CC} = \pm 5$			98		
$V_{CC} = \pm 15$					99					
$V_O = 4$ V _{PP}	$V_{CC} = \pm 5$				93					
	$V_{CC} = \pm 15$				95					
Third intermodulation distortion		$V_{I(PP)} = 4$ V, $G = 1$, $F1 = 3$ MHz, $F2 = 3.5$ MHz			-53		dBc			
Third-order intercept		$V_{I(PP)} = 4$ V, $G = 1$, $F1 = 3$ MHz, $F2 = 3.5$ MHz			41.5		dB			
NOISE PERFORMANCE										
V_n	Input voltage noise	$f = 10$ kHz			1.3		nV/ $\sqrt{\text{Hz}}$			
I_n	Input current noise	$f = 10$ kHz			1		pA/ $\sqrt{\text{Hz}}$			
DC PERFORMANCE										
Open-loop gain		$T_A = +25^\circ\text{C}$		71	78		dB			
		$T_A = \text{full range}$		69						
$V_{(OS)}$	Input offset voltage	$T_A = +25^\circ\text{C}$			0.2	2	mV			
		$T_A = \text{full range}$				3				
	Common-mode input offset voltage, referred to V_{OCM}		$T_A = +25^\circ\text{C}$			0.2		3.5		
	Input offset voltage drift		$T_A = \text{full range}$			4.5			$\mu\text{V}/^\circ\text{C}$	
I_{IB}	Input bias current	$T_A = \text{full range}$			2	6	μA			
I_{OS}	Input offset current	$T_A = \text{full range}$			100	500	nA			
	Offset drift				2		nA/ $^\circ\text{C}$			

(1) The full range temperature is 0°C to $+70^\circ\text{C}$ for the C-suffix, and -40°C to $+85^\circ\text{C}$ for the I-suffix.

(2) Slew rate is measured from an output level range of 25% to 75%.

ELECTRICAL CHARACTERISTICS ⁽¹⁾ (continued)

$V_{CC} = \pm 5\text{ V}$, $R_L = 800\Omega$, and $T_A = +25^\circ\text{C}$, unless otherwise noted.

PARAMETER		TEST CONDITIONS	MIN	TYP	MAX	UNIT
INPUT CHARACTERISTICS						
CMRR	Common-mode rejection ratio	$T_A = \text{full range}$	80	95		dB
V_{ICR}	Common-mode input voltage range		-3.77 to 4.3	-4 to 4.5		V
R_I	Input resistance	Measured into each input terminal		34		M Ω
C_I	Input capacitance, closed loop			4		pF
r_o	Output resistance	Open loop		41		Ω
OUTPUT CHARACTERISTICS						
Output voltage swing		$V_{CC} = 5\text{ V}$	$T_A = +25^\circ\text{C}$	1.2 to 3.8	0.9 to 4.1	V
			$T_A = \text{full range}$	1.3 to 3.7	± 4	
		$V_{CC} = \pm 5\text{ V}$	$T_A = +25^\circ\text{C}$	± 3.7		
			$T_A = \text{full range}$	± 3.6		
I_O Output current		$V_{CC} = 5\text{ V}, R_L = 7\ \Omega$	$T_A = +25^\circ\text{C}$	25	45	mA
			$T_A = \text{full range}$	20		
		$V_{CC} = \pm 5\text{ V}, R_L = 7\ \Omega$	$T_A = +25^\circ\text{C}$	30	55	
			$T_A = \text{full range}$	28		
$V_{CC} = \pm 15\text{ V}, R_L = 7\ \Omega$	$T_A = +25^\circ\text{C}$	60	85			
	$T_A = \text{full range}$	65				
POWER SUPPLY						
V_{CC}	Supply voltage range	Single supply		4	33	V
		Split supply		± 2	± 16.5	
I_{CC}	Quiescent current	$V_{CC} = \pm 5\text{ V}$	$T_A = +25^\circ\text{C}$	12.3	15	mA
			$T_A = \text{full range}$		16	
$I_{CC(SD)}$	Quiescent current (shutdown) (THS4130 only) ⁽³⁾	$V = -5\text{ V}$	$T_A = +25^\circ\text{C}$	0.86	1.4	mA
			$T_A = \text{full range}$		1.5	
PSRR	Power-supply rejection ratio (dc)		$T_A = +25^\circ\text{C}$	73	98	dB
			$T_A = \text{full range}$	70		

(3) For detailed information on the behavior of the power-down circuit, see the [Power-Down Mode](#) section in the [Principles of Operation](#).

TYPICAL CHARACTERISTICS

TABLE OF GRAPHS

			FIGURE
	Small-signal frequency response		Figure 1, Figure 2
	Small-signal frequency response (various supplies)		Figure 3
	Small-signal frequency response (various C_F)		Figure 4
	Small-signal frequency response (various C_L)		Figure 5
	Large-signal transient response (differential in/single out)		Figure 6
	Large-signal frequency response		Figure 7
CMMR	Common-mode rejection ratio	vs Frequency	Figure 8
I_{CC}	Supply current	vs Free-air temperature	Figure 9
		vs Free-air temperature (shutdown state)	Figure 10
I_{IB}	Input bias current	vs Free-air temperature	Figure 11
	Settling time		Figure 12
PSRR	Power-supply rejection ratio	vs Frequency (differential out)	Figure 13
	Large-signal transient response		Figure 14
THD	Total harmonic distortion	vs Frequency	Figure 15
		vs Frequency	Figure 16, Figure 17
	Second-harmonic distortion	vs Output voltage	Figure 18, Figure 19
	Third-harmonic distortion	vs Frequency	Figure 20, Figure 21
		vs Output voltage	Figure 22, Figure 23
V_n	Voltage noise	vs Frequency	Figure 24
I_n	Current noise	vs Frequency	Figure 25
$V_{(OS)}$	Input offset voltage	vs Common-mode output voltage	Figure 26
V_O	Output voltage	vs Differential load resistance	Figure 27
z_o	Output impedance	vs Frequency	Figure 28

TYPICAL CHARACTERISTICS

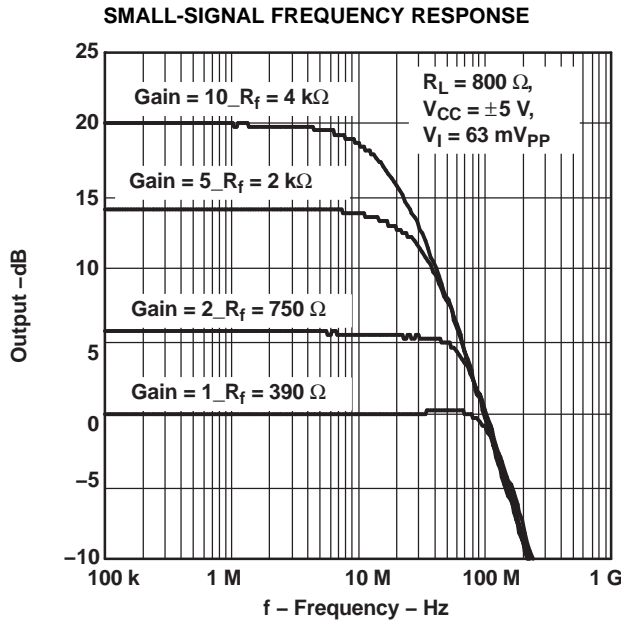

Figure 1.

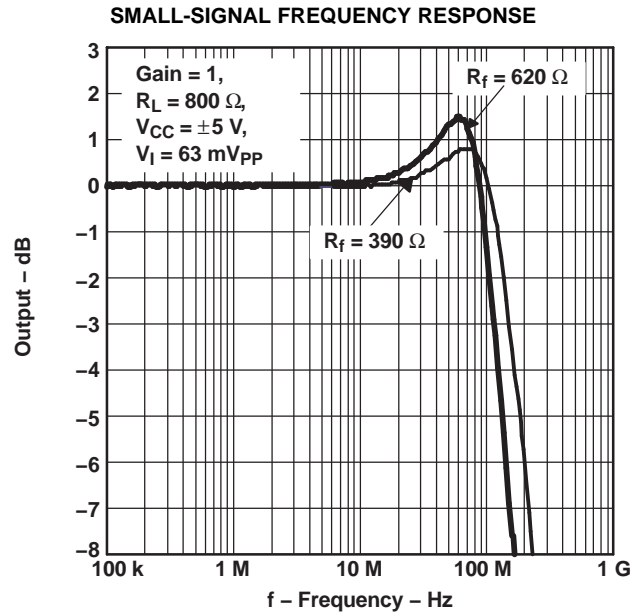

Figure 2.

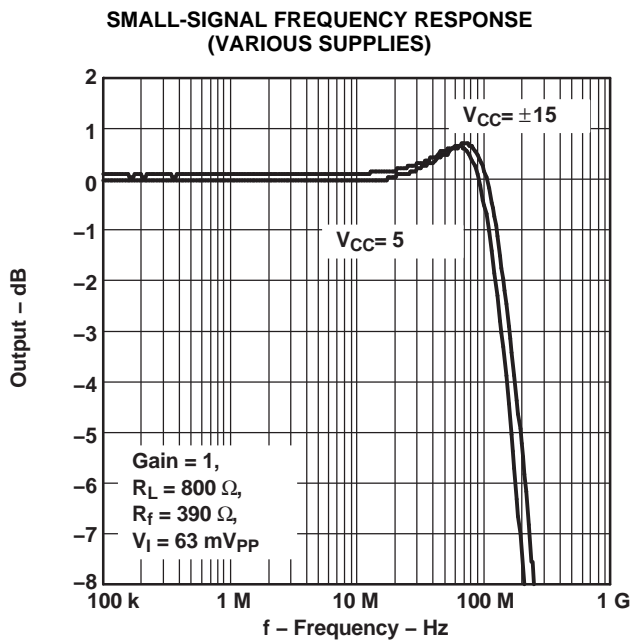

Figure 3.

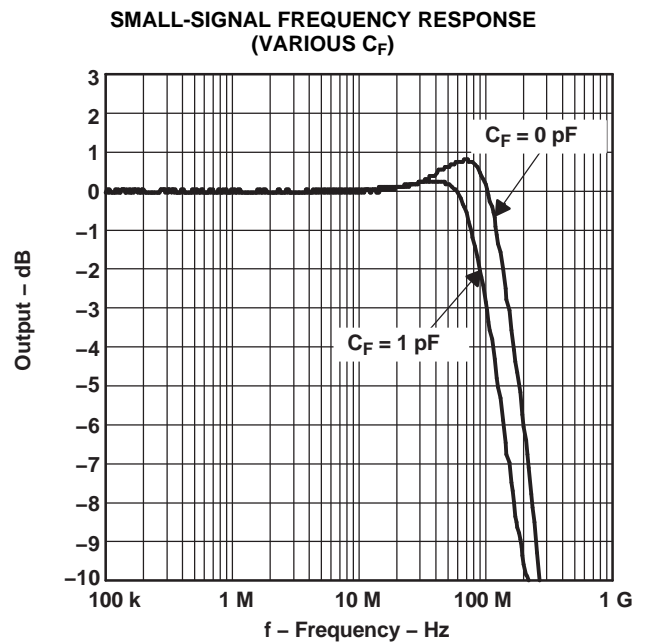

Figure 4.

TYPICAL CHARACTERISTICS (continued)

SMALL-SIGNAL FREQUENCY RESPONSE
(VARIOUS C_L)

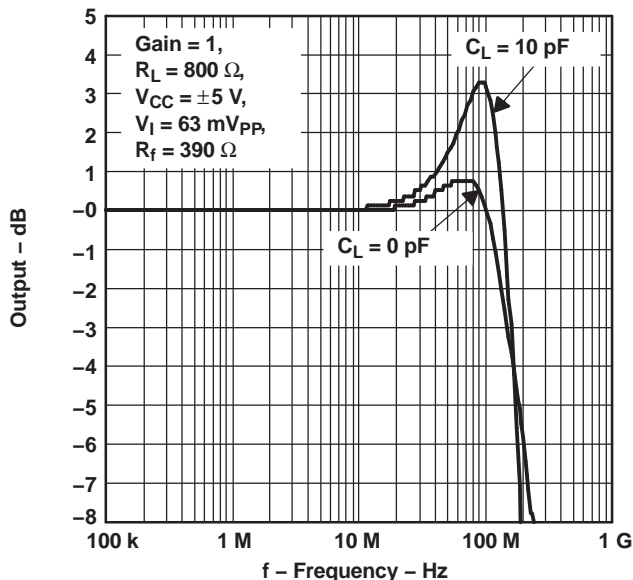

Figure 5.

LARGE-SIGNAL TRANSIENT RESPONSE
(DIFFERENTIAL IN/SINGLE OUT)

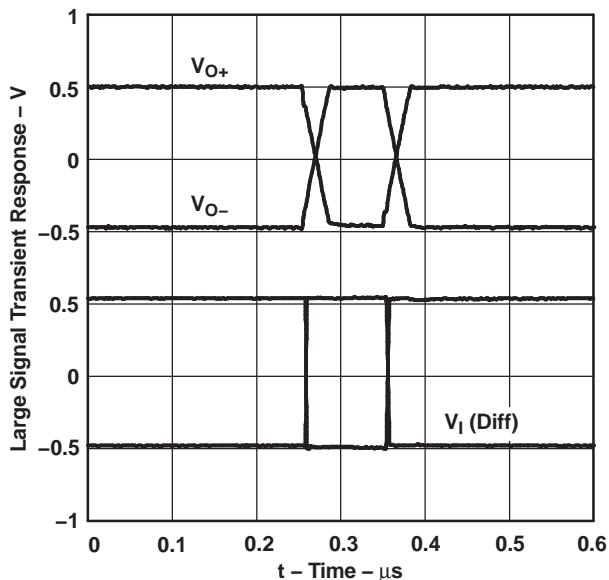

Figure 6.

LARGE-SIGNAL FREQUENCY RESPONSE

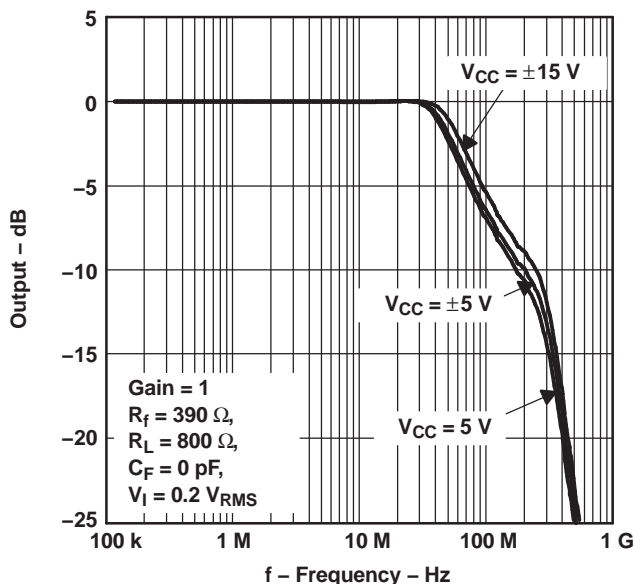

Figure 7.

COMMON-MODE REJECTION RATIO
vs
FREQUENCY

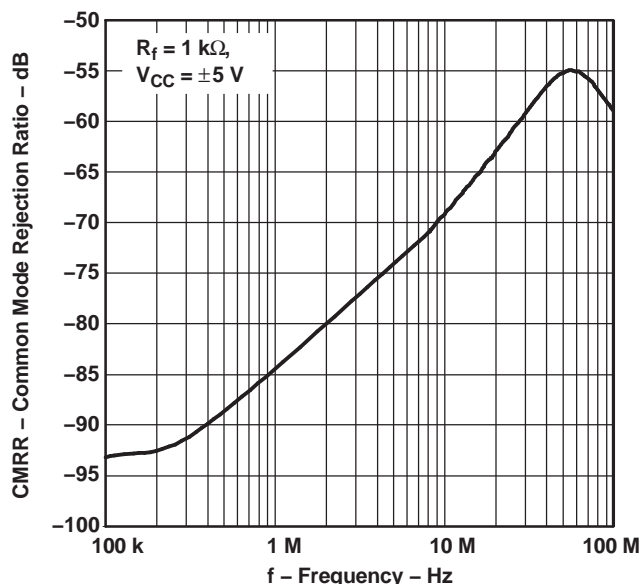
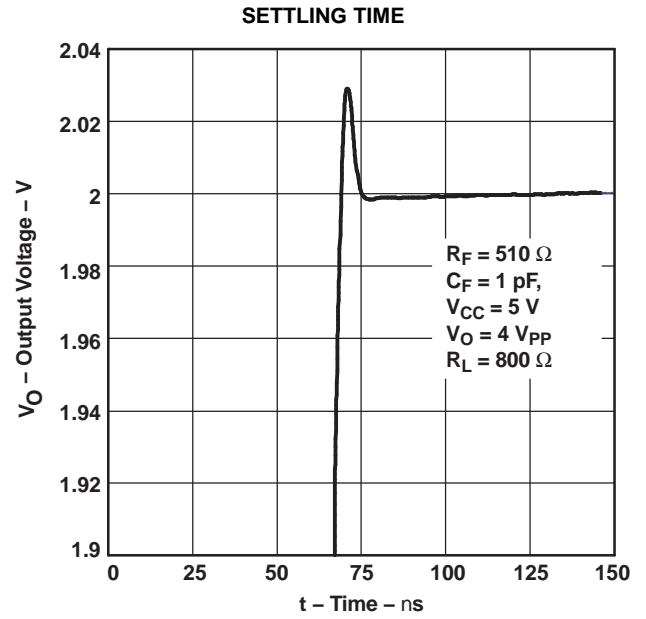
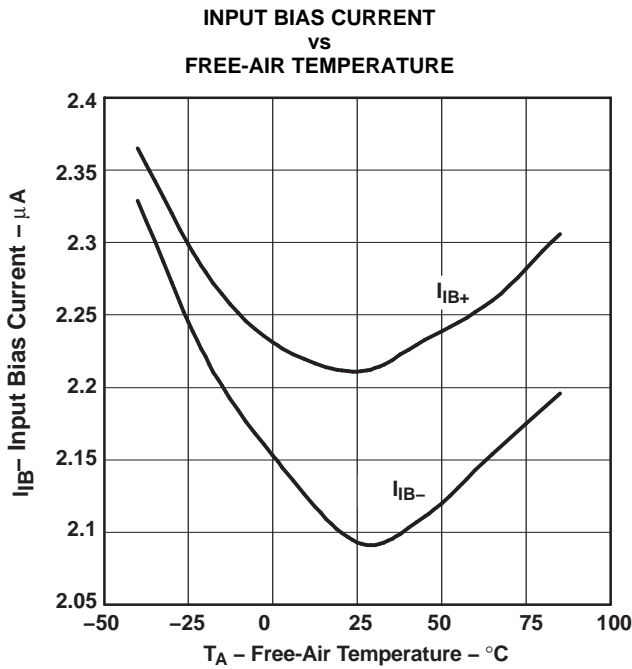
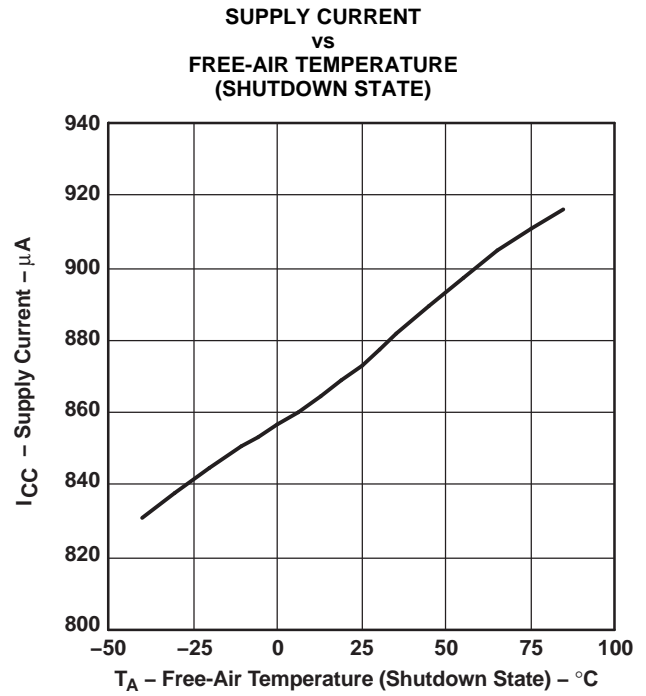
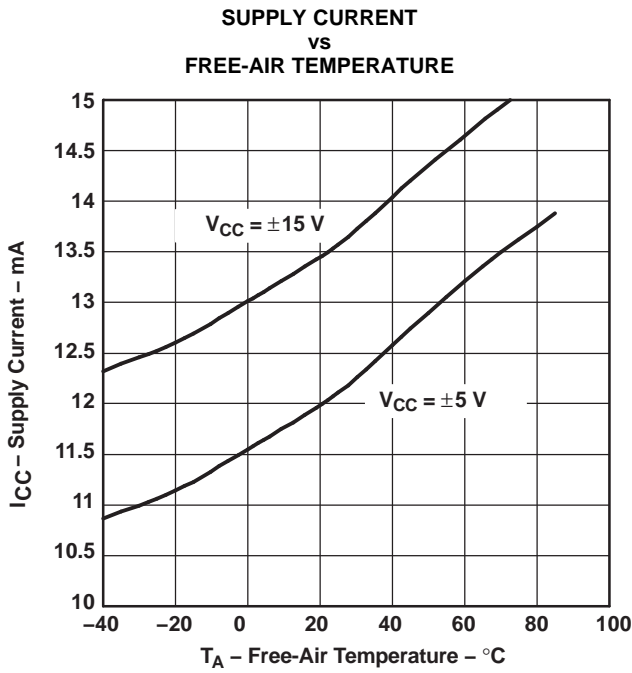

Figure 8.

TYPICAL CHARACTERISTICS (continued)



TYPICAL CHARACTERISTICS (continued)

POWER-SUPPLY REJECTION RATIO
VS
FREQUENCY (DIFFERENTIAL OUT)

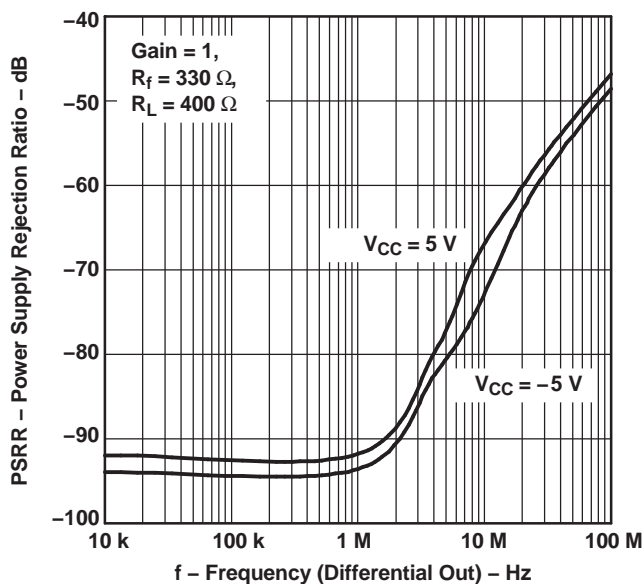

Figure 13.

LARGE-SIGNAL TRANSIENT RESPONSE

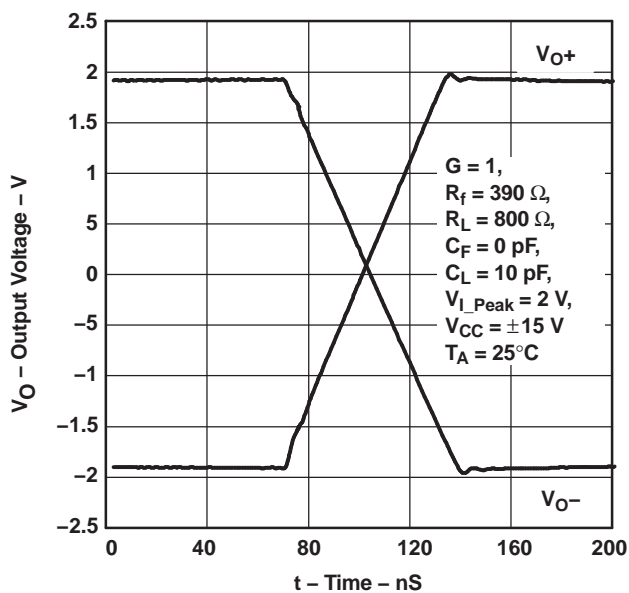

Figure 14.

TOTAL HARMONIC DISTORTION
VS
FREQUENCY

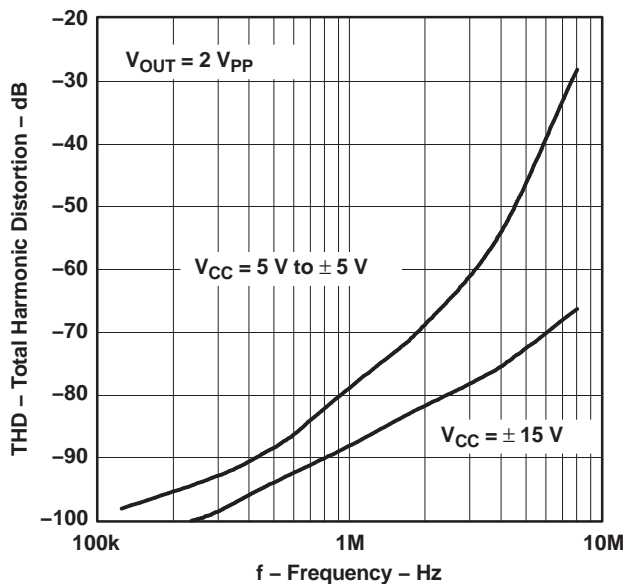

Figure 15.

SECOND-HARMONIC DISTORTION
VS
FREQUENCY

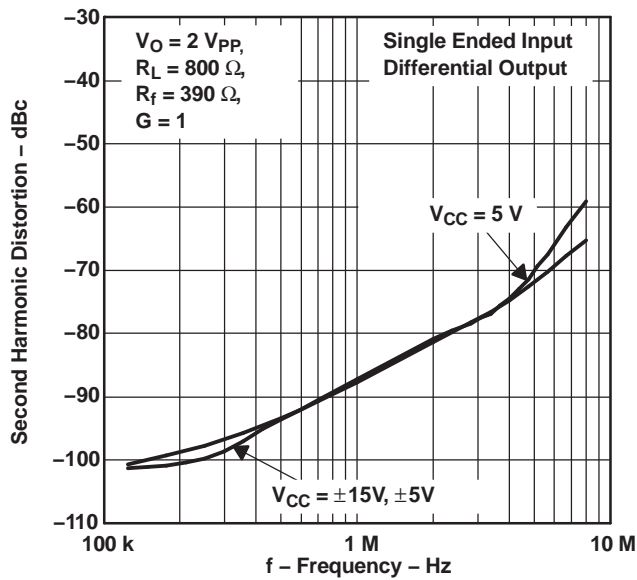

Figure 16.

TYPICAL CHARACTERISTICS (continued)

**SECOND-HARMONIC DISTORTION
vs
FREQUENCY**

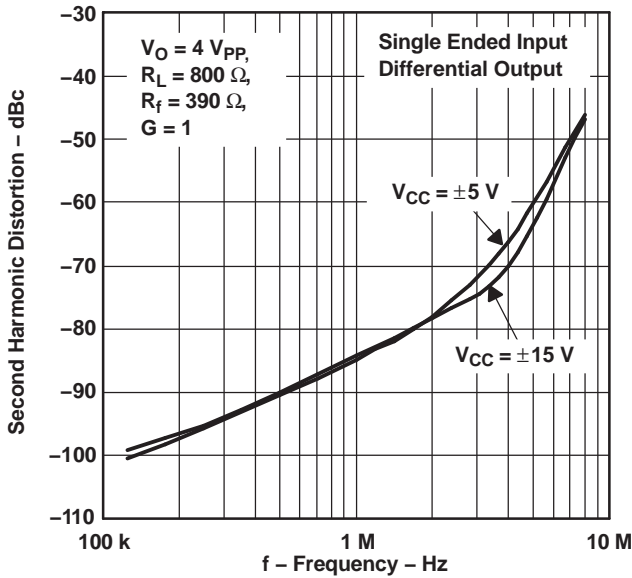

Figure 17.

**SECOND-HARMONIC DISTORTION
vs
OUTPUT VOLTAGE**

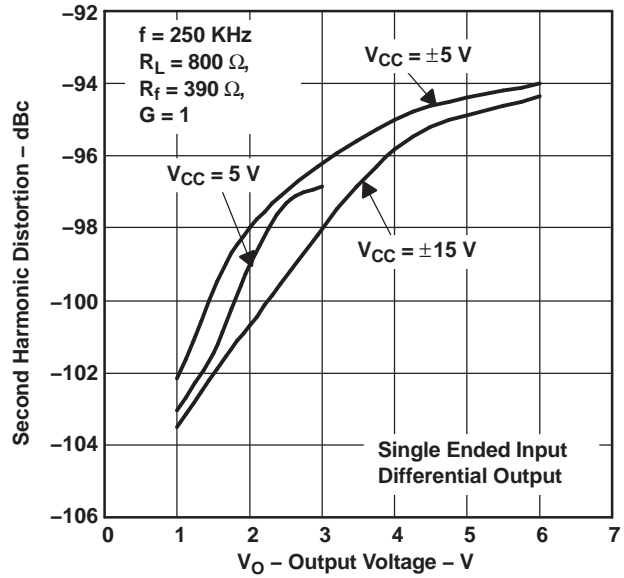

Figure 18.

**SECOND-HARMONIC DISTORTION
vs
OUTPUT VOLTAGE**

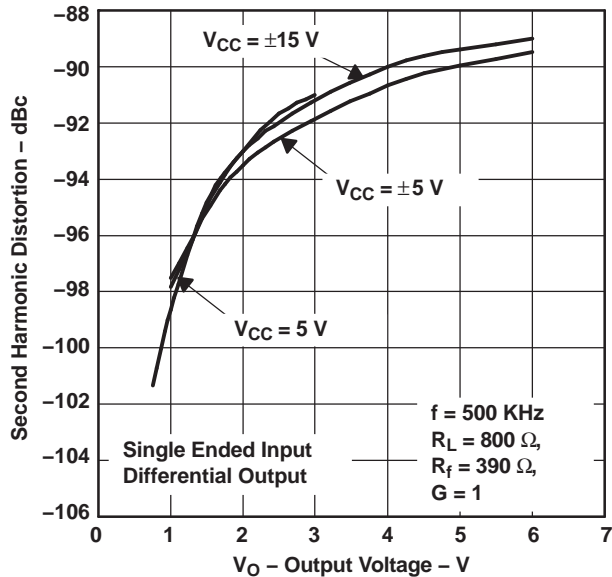

Figure 19.

**THIRD-HARMONIC DISTORTION
vs
FREQUENCY**

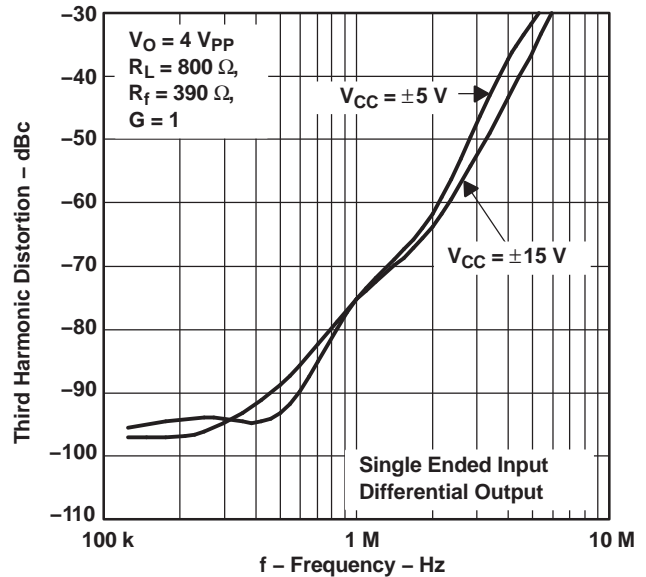

Figure 20.

TYPICAL CHARACTERISTICS (continued)

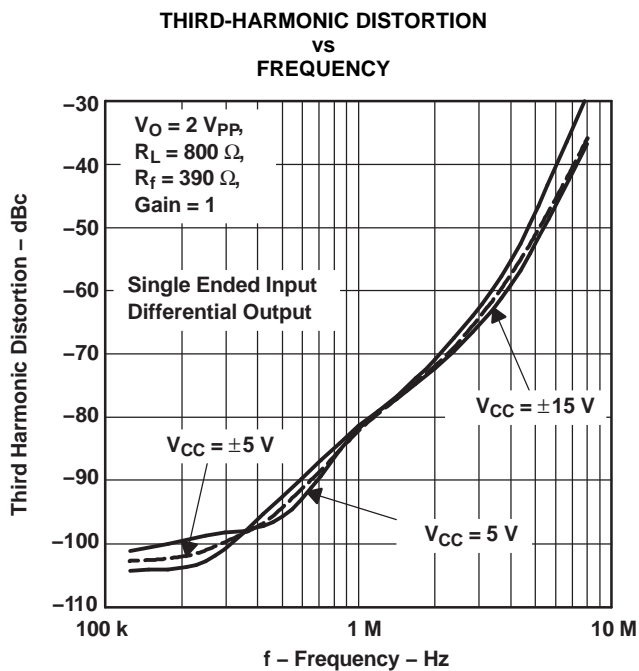

Figure 21.

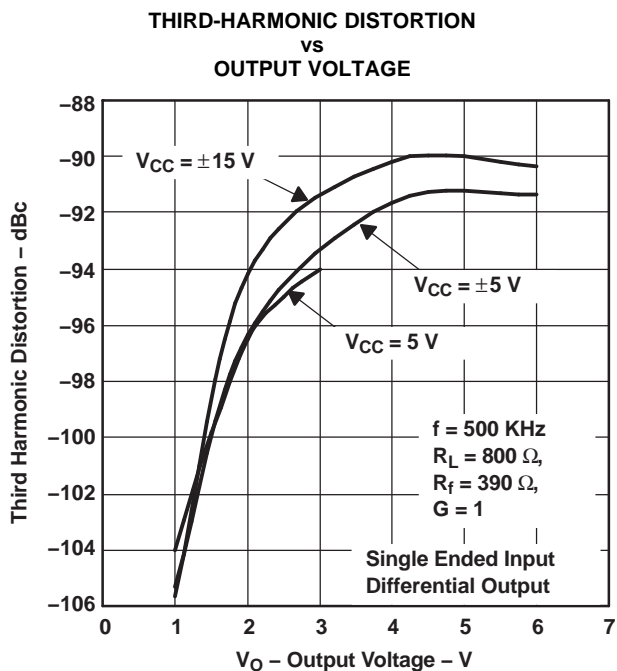

Figure 22.

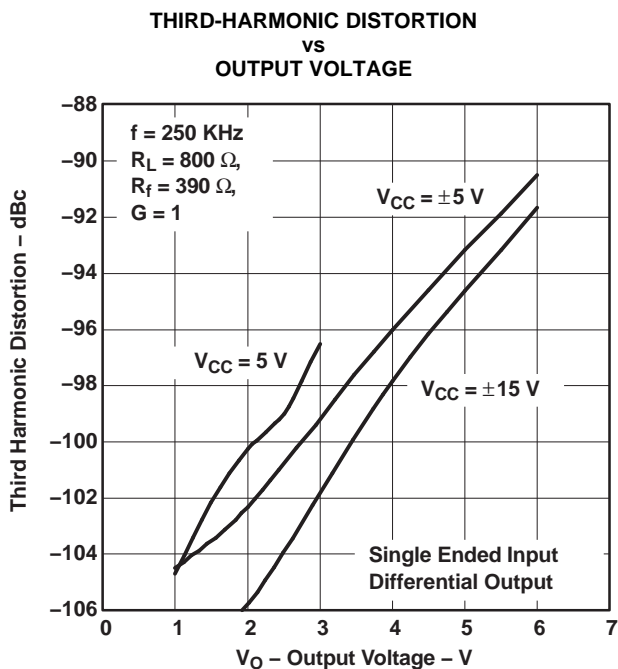

Figure 23.

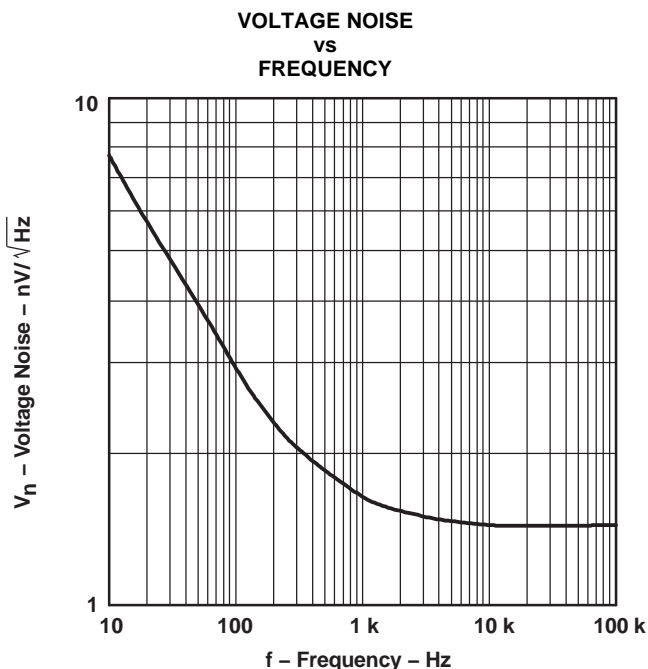

Figure 24.

TYPICAL CHARACTERISTICS (continued)

CURRENT NOISE
VS
FREQUENCY

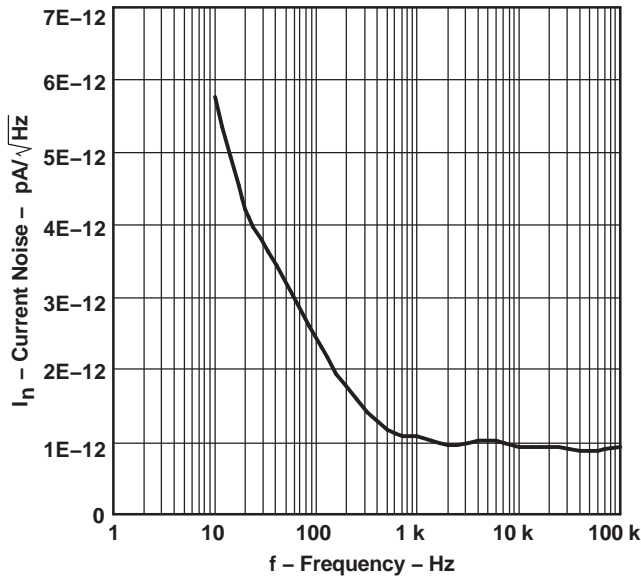

Figure 25.

INPUT OFFSET VOLTAGE
VS
COMMON-MODE OUTPUT VOLTAGE

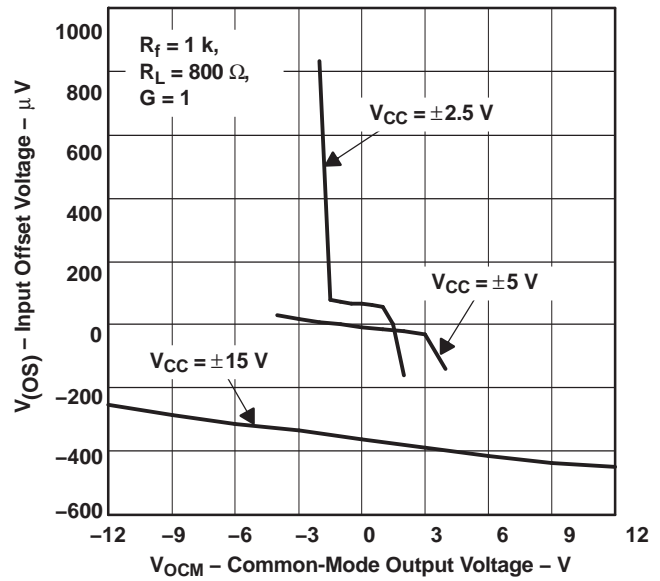

Figure 26.

OUTPUT VOLTAGE
VS
DIFFERENTIAL LOAD RESISTANCE

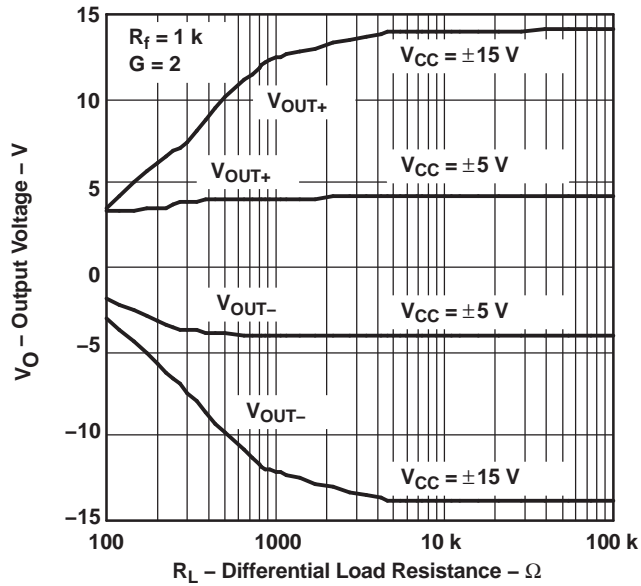

Figure 27.

OUTPUT IMPEDANCE
VS
FREQUENCY

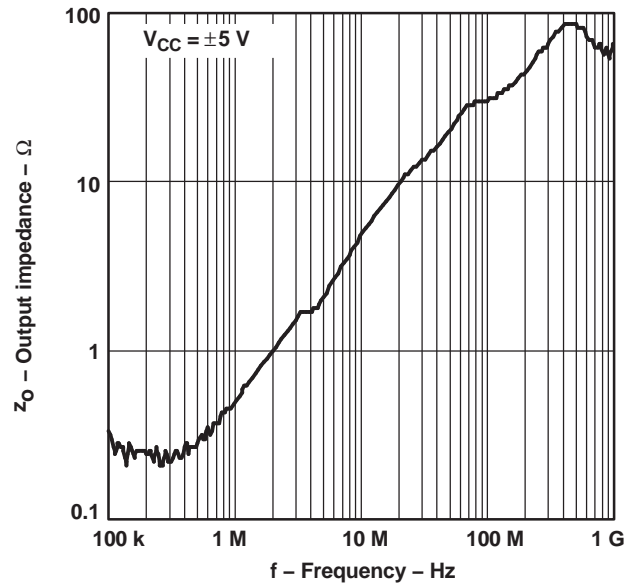

Figure 28.

APPLICATION INFORMATION

RESISTOR MATCHING

Resistor matching is important in fully-differential amplifiers. The balance of the output on the reference voltage depends on matched ratios of the resistor. CMRR, PSRR, and cancellation of the second-harmonic distortion diminish if resistor mismatch occurs. Therefore, it is recommended to use 1% tolerance resistors or better to keep the performance optimized.

V_{OCM} sets the dc level of the output signals. If no voltage is applied to the V_{OCM} pin, it is set to the midrail voltage internally defined as:

$$\frac{(V_{CC+}) + (V_{CC-})}{2} \quad (1)$$

In the differential mode, the V_{OCM} on the two outputs cancel each other. Therefore, the output in the differential mode is the same as the input in the gain of 1. V_{OCM} has a high bandwidth capability up to the typical operation range of the amplifier. For the prevention of noise going through the device, use a 0.1 μF capacitor on the V_{OCM} pin as a bypass capacitor. Figure 29 shows the simplified diagram of the THS413x.

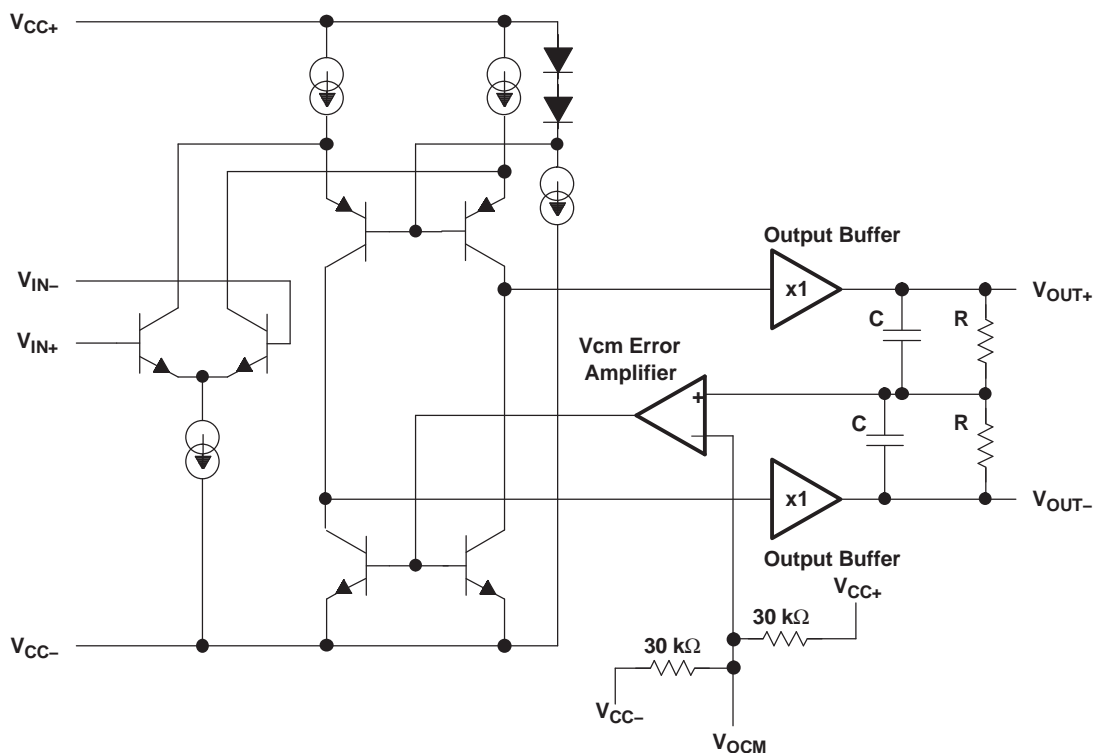

Figure 29. THS413x Simplified Diagram

DATA CONVERTERS

Data converters are one of the most popular applications for the fully-differential amplifiers. Figure 30 shows a typical configuration of a fully-differential amplifier attached to a differential analog-to-digital converter (ADC).

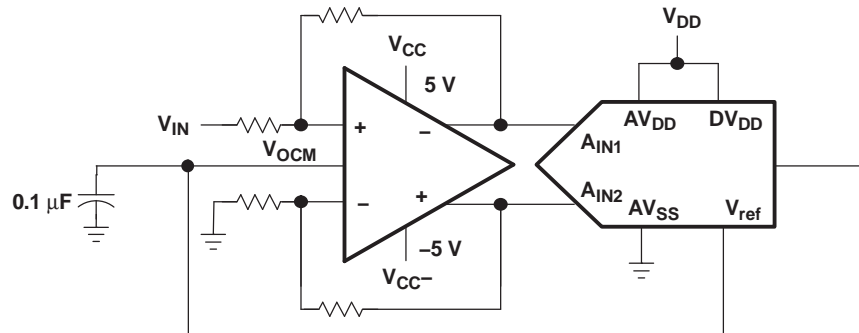

Figure 30. Fully-Differential Amplifier Attached to a Differential ADC

Fully-differential amplifiers can operate with a single supply. V_{OCM} defaults to the midrail voltage, $V_{CC}/2$. The differential output may be fed into a data converter. This method eliminates the use of a transformer in the circuit. If the ADC has a reference voltage output (V_{ref}), then it is recommended to connect it directly to the V_{OCM} of the amplifier using a bypass capacitor for stability. For proper operation, the input common-mode voltage to the input terminal of the amplifier should not exceed the common-mode input voltage range.

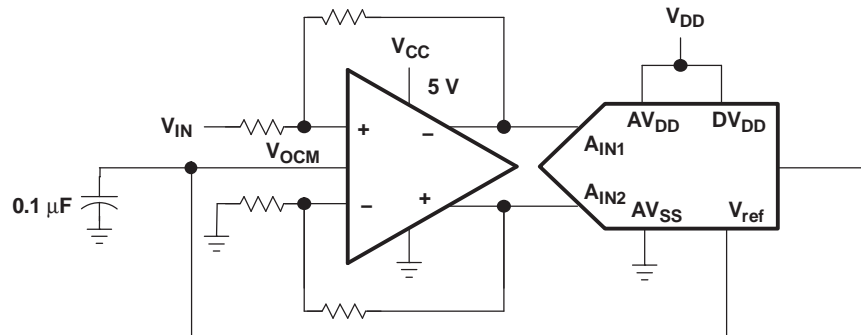

Figure 31. Fully-Differential Amplifier Using a Single Supply

Some single-supply applications may require the input voltage to exceed the common-mode input voltage range. In such cases, the circuit configuration of Figure 32 is suggested to bring the common-mode input voltage within the specifications of the amplifier.

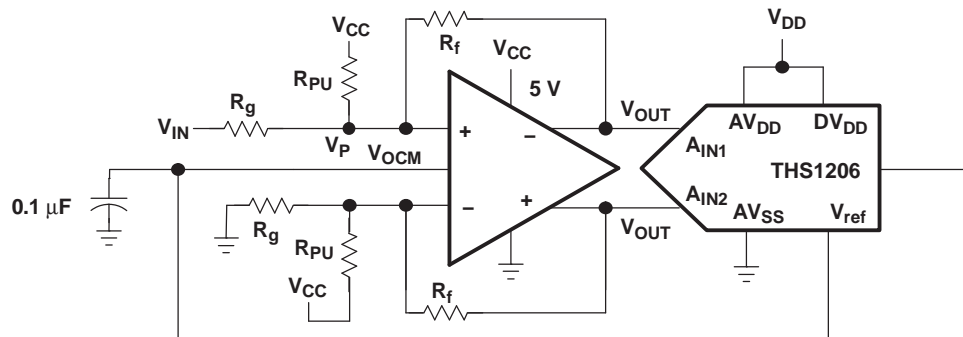

Figure 32. Circuit With Improved Common-Mode Input Voltage

Equation 2 is used to calculate R_{PU} :

$$R_{PU} = \frac{V_P - V_{CC}}{\left((V_{IN} - V_P) \frac{1}{R_G} + (V_{OUT} - V_P) \frac{1}{R_F} \right)} \quad (2)$$

DRIVING A CAPACITIVE LOAD

Driving capacitive loads with high-performance amplifiers is not a problem as long as certain precautions are taken. The first is to realize that the THS413x has been internally compensated to maximize its bandwidth and slew rate performance. When the amplifier is compensated in this manner, capacitive loading directly on the output decreases the device phase margin leading to high-frequency ringing or oscillations. Therefore, for capacitive loads of greater than 10 pF, it is recommended that a resistor be placed in series with the output of the amplifier, as shown in Figure 33. A minimum value of 20 Ω should work well for most applications. For example, in 50-Ω transmission systems, setting the series resistor value to 50 Ω both isolates any capacitance loading and provides the proper line impedance matching at the source end.

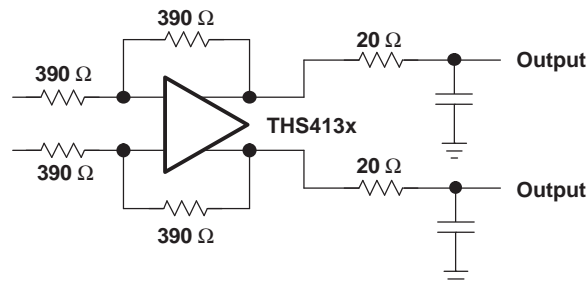

Figure 33. Driving a Capacitive Load

ACTIVE ANTIALIAS FILTERING

For signal conditioning in ADC applications, it is important to limit the input frequency to the ADC. Low-pass filters can prevent the aliasing of the high-frequency noise with the frequency of operation. Figure 34 presents a method by which the noise may be filtered in the THS413x.

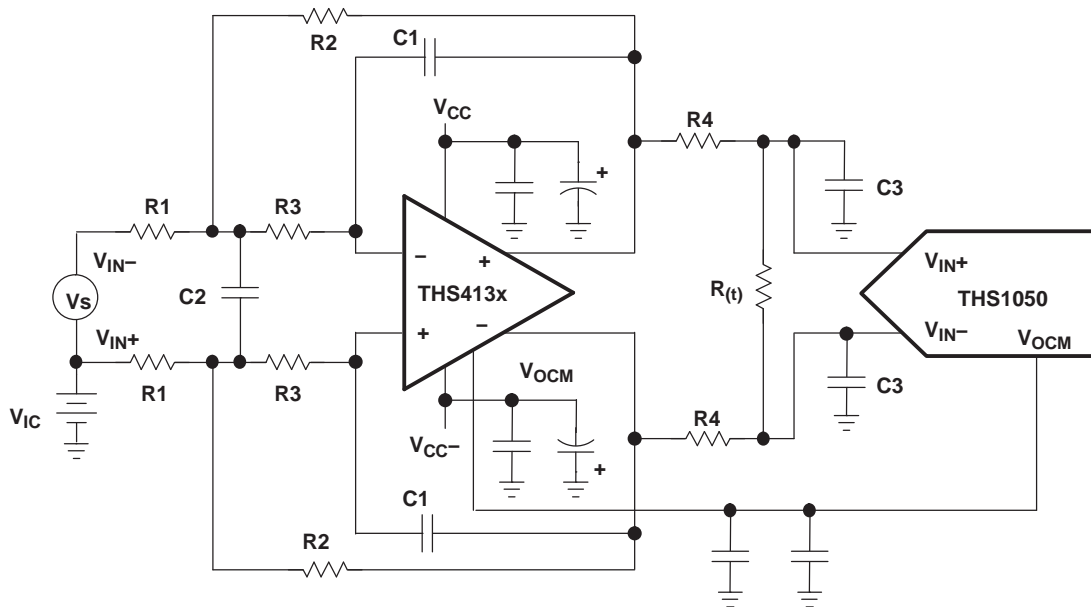

Figure 34. Antialias Filtering

The transfer function for this filter circuit is:

$$H_d(f) = \left[\frac{K}{-\left(\frac{f}{\text{FSF} \times f_c}\right)^2 + \frac{1}{Q} \frac{jf}{\text{FSF} \times f_c} + 1} \right] \times \left[\frac{\frac{R_t}{2R_4 + R_t}}{1 + \frac{j2\pi f R_4 R_t C_3}{2R_4 + R_t}} \right] \quad \text{Where } K = \frac{R_2}{R_1} \quad (3)$$

$$\text{FSF} \times f_c = \frac{1}{2\pi \sqrt{2} \times R_2 R_3 C_1 C_2} \quad \text{and } Q = \frac{\sqrt{2} \times R_2 R_3 C_1 C_2}{R_3 C_1 + R_2 C_1 + K R_3 C_1} \quad (4)$$

K sets the pass band gain, f_c is the cutoff frequency for the filter, FSF is a frequency scaling factor, and Q is the quality factor.

$$\text{FSF} = \sqrt{\text{Re}^2 + |\text{Im}|^2} \quad \text{and } Q = \frac{\sqrt{\text{Re}^2 + |\text{Im}|^2}}{2\text{Re}} \quad (5)$$

where Re is the real part, and Im is the imaginary part of the complex pole pair. Setting $R_2 = R$, $R_3 = mR$, $C_1 = C$, and $C_2 = nC$ results in:

$$\text{FSF} \times f_c = \frac{1}{2\pi RC \sqrt{2} \times mn} \quad \text{and } Q = \frac{\sqrt{2} \times mn}{1 + m(1 + K)} \quad (6)$$

Start by determining the ratios, m and n, required for the gain and Q of the filter type being designed, then select C and calculate R for the desired f_c .

PRINCIPLES OF OPERATION

THEORY OF OPERATION

The THS413x is a fully-differential amplifier. Differential amplifiers are typically *differential in/single out*, whereas fully-differential amplifiers are *differential in/differential out*.

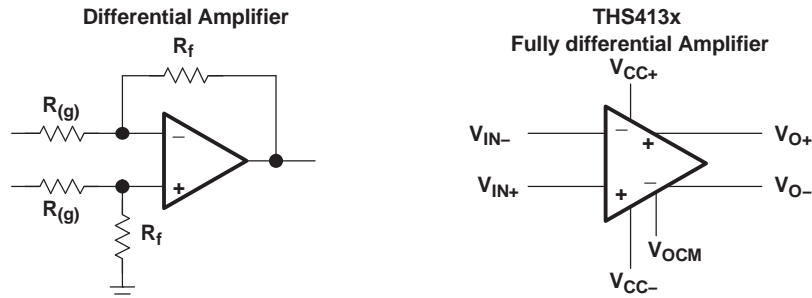

Figure 35. Differential Amplifier Versus a Fully-Differential Amplifier

To understand the THS413x fully-differential amplifiers, the definition for the pin outs of the amplifier are provided.

$$\text{Input voltage definition} \quad V_{ID} = (V_{I+}) - (V_{I-}) \quad V_{IC} = \frac{(V_{I+}) + (V_{I-})}{2} \quad (7)$$

$$\text{Output voltage definition} \quad V_{OD} = (V_{O+}) - (V_{O-}) \quad V_{OC} = \frac{(V_{O+}) + (V_{O-})}{2} \quad (8)$$

$$\text{Transfer function} \quad V_{OD} = V_{ID} \times A_{(f)} \quad (9)$$

$$\text{Output common mode voltage} \quad V_{OC} = V_{OCM} \quad (10)$$

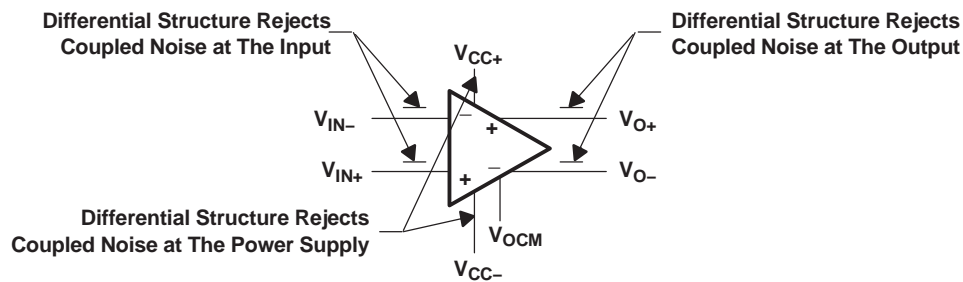
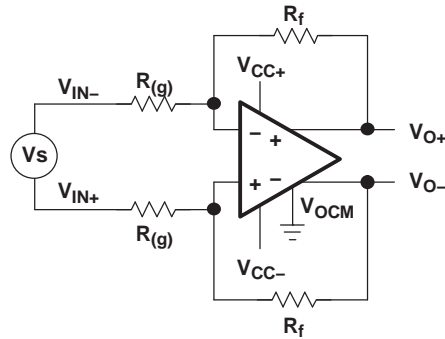

Figure 36. Definition of the Fully-Differential Amplifier

Figure 37 and Figure 38 depict the differences between the operation of the THS413x fully-differential amplifier in two different modes. Fully-differential amplifiers can work with differential input or can be implemented as single in/differential out.



Note: For proper operation, maintain symmetry by setting $R_{f1} = R_{f2} = R_f$ and $R_{(g)1} = R_{(g)2} = R_{(g)} \Rightarrow A = R_f/R_{(g)}$

Figure 37. Amplifying Differential Signals

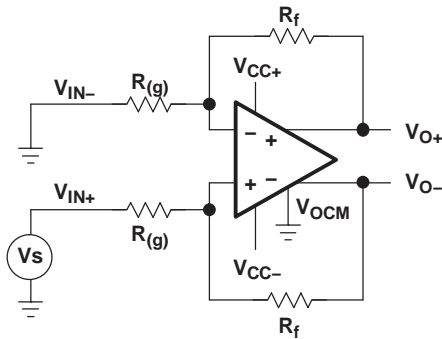

RECOMMENDED RESISTOR VALUES

GAIN	$R_{(g)} \Omega$	$R_f \Omega$
1	390	390
2	374	750
5	402	2010
10	402	4020

Figure 38. Single In With Differential Out

If each output is measured independently, each output is one-half of the input signal when gain is 1. The following equations express the transfer function for each output:

$$V_O = \frac{1}{2} V_I \tag{11}$$

The second output is equal and opposite in sign:

$$V_O = -\frac{1}{2} V_I \tag{12}$$

Fully-differential amplifiers may be viewed as two inverting amplifiers. In this case, the equation of an inverting amplifier holds true for gain calculations. One advantage of fully-differential amplifiers is that they offer twice as much dynamic range compared to single-ended amplifiers. For example, a 1- V_{PP} ADC can only support an input signal of 1 V_{PP} . If the output of the amplifier is 2 V_{PP} , then it is not as practical to feed a 2- V_{PP} signal into the targeted ADC. Using a fully-differential amplifier enables the user to break down the output into two 1- V_{PP} signals with opposite signs and feed them into the differential input nodes of the ADC. In practice, the designer has been able to feed a 2-V peak-to-peak signal into a 1-V differential ADC with the help of a fully-differential amplifier. The final result indicates twice as much dynamic range. Figure 39 illustrates the increase in dynamic range. The gain factor should be considered in this scenario. The THS413x fully-differential amplifier offers an improved CMRR and PSRR due to its symmetrical input and output. Furthermore, second-harmonic distortion is improved. Second harmonics tend to cancel because of the symmetrical output.

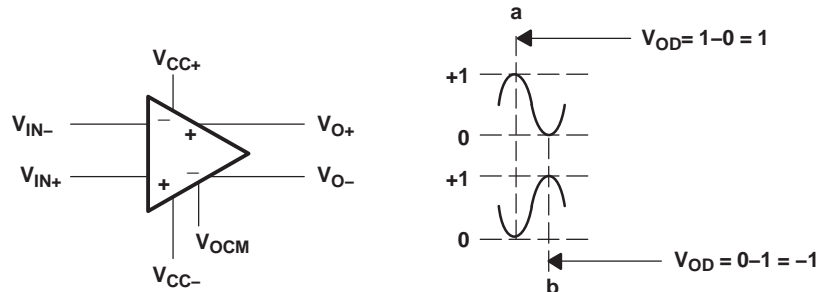

Figure 39. Fully-Differential Amplifier With Two 1- V_{PP} Signals

Similar to the standard inverting amplifier configuration, input impedance of a fully-differential amplifier is selected by the input resistor, $R_{(g)}$. If input impedance is a constraint in design, the designer may choose to implement the differential amplifier as an instrumentation amplifier. This configuration improves the input impedance of the fully-differential amplifier. Figure 40 depicts the general format of instrumentation amplifiers.

The general transfer function for this circuit is:

$$\frac{V_{OD}}{V_{IN1} - V_{IN2}} = \frac{R_f}{R_{(g)}} \left(1 + \frac{2R_2}{R_1} \right) \quad (13)$$

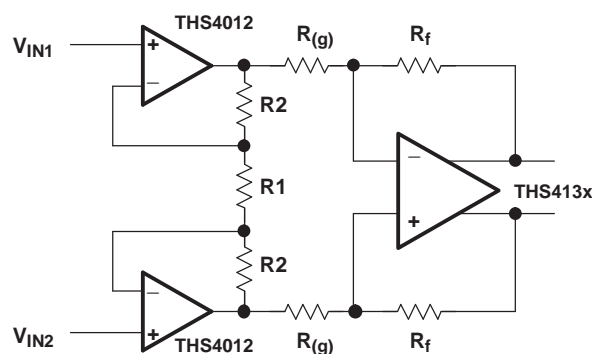

Figure 40. Instrumentation Amplifier

CIRCUIT LAYOUT CONSIDERATIONS

To achieve the levels of high-frequency performance of the THS413x, follow proper printed-circuit board (PCB) high-frequency design techniques. A general set of guidelines is given below. In addition, a THS413x evaluation board is available to use as a guide for layout or for evaluating the device performance.

- **Ground planes**—It is highly recommended that a ground plane be used on the board to provide all components with a low inductive ground connection. However, in the areas of the amplifier inputs and output, the ground plane can be removed to minimize the stray capacitance.
- **Proper power-supply decoupling**—Use a 6.8- μ F tantalum capacitor in parallel with a 0.1- μ F ceramic capacitor on each supply terminal. It may be possible to share the tantalum among several amplifiers depending on the application, but a 0.1- μ F ceramic capacitor should always be used on the supply terminal of every amplifier. In addition, the 0.1- μ F capacitor should be placed as close as possible to the supply terminal. As this distance increases, the inductance in the connecting trace makes the capacitor less effective. The designer should strive for distances of less than 0.1 inches between the device power terminals and the ceramic capacitors.
- **Sockets**—Sockets are not recommended for high-speed operational amplifiers. The additional lead inductance in the socket pins often lead to stability problems. Surface-mount packages soldered directly to the printed-circuit board are the best implementation.
- **Short trace runs/compact part placements**—Optimum high-frequency performance is achieved when stray series inductance has been minimized. To realize this, the circuit layout should be made as compact as possible, thereby minimizing the length of all trace runs. Particular attention should be paid to the inverting input of the amplifier. Its length should be kept as short as possible. This helps to minimize stray capacitance at the input of the amplifier.
- **Surface-mount passive components**—Using surface-mount passive components is recommended for high-frequency amplifier circuits for several reasons. First, because of the extremely low lead inductance of surface-mount components, the problem with stray series inductance is greatly reduced. Second, the small size of surface-mount components naturally leads to a more compact layout thereby minimizing both stray inductance and capacitance. If leaded components are used, it is recommended that the lead lengths be kept as short as possible.

POWER-DOWN MODE

The power-down mode is used when power saving is required. The power-down terminal (\overline{PD}) found on the THS413x is an active low terminal. If it is left as a no-connect terminal, the device always stays on due to an internal 50 k Ω resistor to V_{CC} . The threshold voltage for this terminal is approximately 1.4 V above V_{CC-} . This means that if the \overline{PD} terminal is 1.4 V above V_{CC-} , the device is active. If the \overline{PD} terminal is less than 1.4 V above V_{CC-} , the device is off. For example, if $V_{CC-} = -5$ V, then the device is on when \overline{PD} reaches -3.6 V, (-5 V + 1.4 V = -3.6 V). By the same calculation, the device is off below -3.6 V. It is recommended to pull the terminal to V_{CC-} in order to turn the device off. Figure 41 shows the simplified version of the power-down circuit. While in the power-down state, the amplifier goes into a high-impedance state. The amplifier output impedance is typically greater than 1 M Ω in the power-down state.

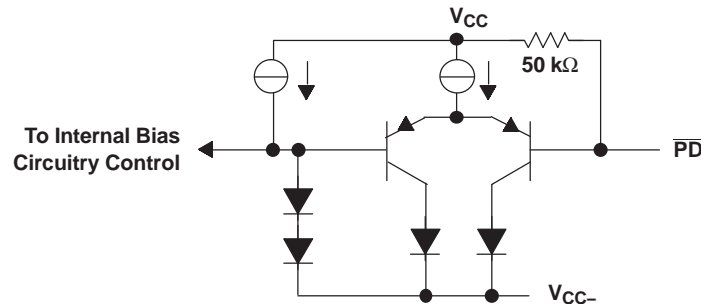

Figure 41. Simplified Power-Down Circuit

Due to the similarity of the standard inverting amplifier configuration, the output impedance appears to be very low while in the power-down state. This is because the feedback resistor (R_f) and the gain resistor ($R_{(g)}$) are still connected to the circuit. Therefore, a current path is allowed between the input of the amplifier and the output of the amplifier. An example of the closed loop output impedance is shown in Figure 42.

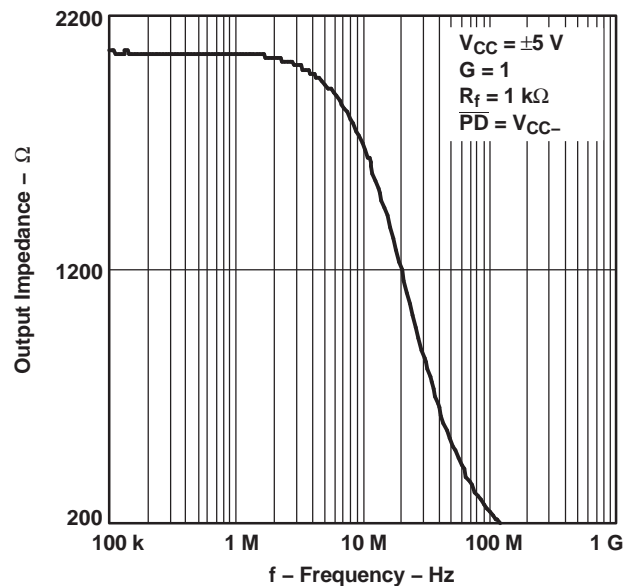

Figure 42. Output Impedance (In Power-Down) vs Frequency

GENERAL PowerPAD DESIGN CONSIDERATIONS

The THS413x is available packaged in a thermally-enhanced DGN package, which is a member of the PowerPAD family of packages. This package is constructed using a downset leadframe upon which the die is mounted (see [Figure 43a](#) and [Figure 43b](#)). This arrangement results in the lead frame being exposed as a thermal pad on the underside of the package (see [Figure 43c](#)). Because this thermal pad has direct thermal contact with the die, excellent thermal performance can be achieved by providing a good thermal path away from the thermal pad.

The PowerPAD package allows for both assembly and thermal management in one manufacturing operation. During the surface-mount solder operation (when the leads are being soldered), the thermal pad can also be soldered to a copper area underneath the package. Through the use of thermal paths within this copper area, heat can be conducted away from the package into either a ground plane or other heat dissipating device.

The PowerPAD package represents a breakthrough in combining the small area and ease of assembly of the surface mount with the previously awkward mechanical methods of heatsinking.

More complete details of the PowerPAD installation process and thermal management techniques can be found in the Texas Instruments Technical Brief, *PowerPAD Thermally-Enhanced Package (SLMA002)*. This document can be found at the TI web site (www.ti.com) by searching on the key word PowerPAD. The document can also be ordered through your local TI sales office. Refer to literature number SLMA002 when ordering.

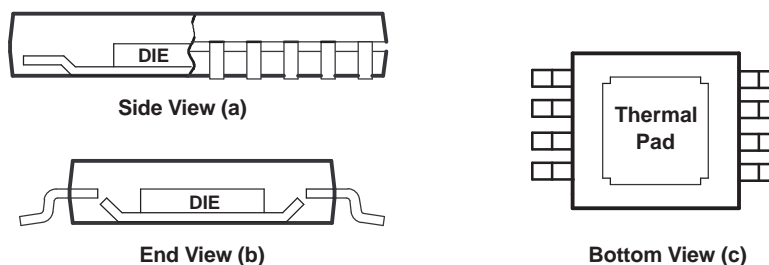

- A. The thermal pad is electrically isolated from all terminals in the package.

Figure 43. Views of Thermally-Enhanced DGN Package

REVISION HISTORY

NOTE: Page numbers for previous revisions may differ from page numbers in the current version.

Changes from Revision F (January 2006) to Revision G

Page

-
- Changed DGK package specifications in the *Dissipation Rating* table 2
-

PACKAGING INFORMATION

Orderable Device	Status ⁽¹⁾	Package Type	Package Drawing	Pins	Package Qty	Eco Plan ⁽²⁾	Lead/Ball Finish	MSL Peak Temp ⁽³⁾
THS4130CD	ACTIVE	SOIC	D	8	75	Green (RoHS & no Sb/Br)	CU NIPDAU	Level-1-260C-UNLIM
THS4130CDG4	ACTIVE	SOIC	D	8	75	Green (RoHS & no Sb/Br)	CU NIPDAU	Level-1-260C-UNLIM
THS4130CDGK	ACTIVE	MSOP	DGK	8	80	Green (RoHS & no Sb/Br)	CU NIPDAU	Level-1-260C-UNLIM
THS4130CDGKG4	ACTIVE	MSOP	DGK	8	80	Green (RoHS & no Sb/Br)	CU NIPDAU	Level-1-260C-UNLIM
THS4130CDGKR	ACTIVE	MSOP	DGK	8	2500	Green (RoHS & no Sb/Br)	CU NIPDAU	Level-1-260C-UNLIM
THS4130CDGKRG4	ACTIVE	MSOP	DGK	8	2500	Green (RoHS & no Sb/Br)	CU NIPDAU	Level-1-260C-UNLIM
THS4130CDGN	ACTIVE	MSOP-Power PAD	DGN	8	80	Green (RoHS & no Sb/Br)	CU NIPDAU	Level-1-260C-UNLIM
THS4130CDGNG4	ACTIVE	MSOP-Power PAD	DGN	8	80	Green (RoHS & no Sb/Br)	CU NIPDAU	Level-1-260C-UNLIM
THS4130CDGNR	ACTIVE	MSOP-Power PAD	DGN	8	2500	Green (RoHS & no Sb/Br)	CU NIPDAU	Level-1-260C-UNLIM
THS4130CDGNRG4	ACTIVE	MSOP-Power PAD	DGN	8	2500	Green (RoHS & no Sb/Br)	CU NIPDAU	Level-1-260C-UNLIM
THS4130ID	ACTIVE	SOIC	D	8	75	Green (RoHS & no Sb/Br)	CU NIPDAU	Level-1-260C-UNLIM
THS4130IDG4	ACTIVE	SOIC	D	8	75	Green (RoHS & no Sb/Br)	CU NIPDAU	Level-1-260C-UNLIM
THS4130IDGK	ACTIVE	MSOP	DGK	8	80	Green (RoHS & no Sb/Br)	CU NIPDAU	Level-1-260C-UNLIM
THS4130IDGKG4	ACTIVE	MSOP	DGK	8	80	Green (RoHS & no Sb/Br)	CU NIPDAU	Level-1-260C-UNLIM
THS4130IDGKR	ACTIVE	MSOP	DGK	8	2500	Green (RoHS & no Sb/Br)	CU NIPDAU	Level-1-260C-UNLIM
THS4130IDGKRG4	ACTIVE	MSOP	DGK	8	2500	Green (RoHS & no Sb/Br)	CU NIPDAU	Level-1-260C-UNLIM
THS4130IDGN	ACTIVE	MSOP-Power PAD	DGN	8	80	Green (RoHS & no Sb/Br)	CU NIPDAU	Level-1-260C-UNLIM
THS4130IDGNG4	ACTIVE	MSOP-Power PAD	DGN	8	80	Green (RoHS & no Sb/Br)	CU NIPDAU	Level-1-260C-UNLIM
THS4130IDGNR	ACTIVE	MSOP-Power PAD	DGN	8	2500	Green (RoHS & no Sb/Br)	CU NIPDAU	Level-1-260C-UNLIM
THS4130IDGNRG4	ACTIVE	MSOP-Power PAD	DGN	8	2500	Green (RoHS & no Sb/Br)	CU NIPDAU	Level-1-260C-UNLIM
THS4130IDR	ACTIVE	SOIC	D	8	2500	Green (RoHS & no Sb/Br)	CU NIPDAU	Level-1-260C-UNLIM
THS4130IDRG4	ACTIVE	SOIC	D	8	2500	Green (RoHS & no Sb/Br)	CU NIPDAU	Level-1-260C-UNLIM

Orderable Device	Status ⁽¹⁾	Package Type	Package Drawing	Pins	Package Qty	Eco Plan ⁽²⁾	Lead/Ball Finish	MSL Peak Temp ⁽³⁾
						no Sb/Br)		
THS4131CD	ACTIVE	SOIC	D	8	75	Green (RoHS & no Sb/Br)	CU NIPDAU	Level-1-260C-UNLIM
THS4131CDG4	ACTIVE	SOIC	D	8	75	Green (RoHS & no Sb/Br)	CU NIPDAU	Level-1-260C-UNLIM
THS4131CDGK	ACTIVE	MSOP	DGK	8	80	Green (RoHS & no Sb/Br)	CU NIPDAU	Level-1-260C-UNLIM
THS4131CDGKG4	ACTIVE	MSOP	DGK	8	80	Green (RoHS & no Sb/Br)	CU NIPDAU	Level-1-260C-UNLIM
THS4131CDGKR	ACTIVE	MSOP	DGK	8	2500	Green (RoHS & no Sb/Br)	CU NIPDAU	Level-1-260C-UNLIM
THS4131CDGKRG4	ACTIVE	MSOP	DGK	8	2500	Green (RoHS & no Sb/Br)	CU NIPDAU	Level-1-260C-UNLIM
THS4131CDGN	ACTIVE	MSOP-Power PAD	DGN	8	80	Green (RoHS & no Sb/Br)	CU NIPDAU	Level-1-260C-UNLIM
THS4131CDGNG4	ACTIVE	MSOP-Power PAD	DGN	8	80	Green (RoHS & no Sb/Br)	CU NIPDAU	Level-1-260C-UNLIM
THS4131CDGNR	ACTIVE	MSOP-Power PAD	DGN	8	2500	Green (RoHS & no Sb/Br)	CU NIPDAU	Level-1-260C-UNLIM
THS4131CDGNRG4	ACTIVE	MSOP-Power PAD	DGN	8	2500	Green (RoHS & no Sb/Br)	CU NIPDAU	Level-1-260C-UNLIM
THS4131CDR	ACTIVE	SOIC	D	8	2500	Green (RoHS & no Sb/Br)	CU NIPDAU	Level-1-260C-UNLIM
THS4131CDRG4	ACTIVE	SOIC	D	8	2500	Green (RoHS & no Sb/Br)	CU NIPDAU	Level-1-260C-UNLIM
THS4131ID	ACTIVE	SOIC	D	8	75	Green (RoHS & no Sb/Br)	CU NIPDAU	Level-1-260C-UNLIM
THS4131IDG4	ACTIVE	SOIC	D	8	75	Green (RoHS & no Sb/Br)	CU NIPDAU	Level-1-260C-UNLIM
THS4131IDGK	ACTIVE	MSOP	DGK	8	80	Green (RoHS & no Sb/Br)	CU NIPDAU	Level-1-260C-UNLIM
THS4131IDGKG4	ACTIVE	MSOP	DGK	8	80	Green (RoHS & no Sb/Br)	CU NIPDAU	Level-1-260C-UNLIM
THS4131IDGKR	ACTIVE	MSOP	DGK	8	2500	Green (RoHS & no Sb/Br)	CU NIPDAU	Level-1-260C-UNLIM
THS4131IDGKRG4	ACTIVE	MSOP	DGK	8	2500	Green (RoHS & no Sb/Br)	CU NIPDAU	Level-1-260C-UNLIM
THS4131IDGN	ACTIVE	MSOP-Power PAD	DGN	8	80	Green (RoHS & no Sb/Br)	CU NIPDAU	Level-1-260C-UNLIM
THS4131IDGNG4	ACTIVE	MSOP-Power PAD	DGN	8	80	Green (RoHS & no Sb/Br)	CU NIPDAU	Level-1-260C-UNLIM
THS4131IDGNR	ACTIVE	MSOP-Power PAD	DGN	8	2500	Green (RoHS & no Sb/Br)	CU NIPDAU	Level-1-260C-UNLIM
THS4131IDGNRG4	ACTIVE	MSOP-Power PAD	DGN	8	2500	Green (RoHS & no Sb/Br)	CU NIPDAU	Level-1-260C-UNLIM

Orderable Device	Status ⁽¹⁾	Package Type	Package Drawing	Pins	Package Qty	Eco Plan ⁽²⁾	Lead/Ball Finish	MSL Peak Temp ⁽³⁾
THS4131IDR	ACTIVE	SOIC	D	8	2500	Green (RoHS & no Sb/Br)	CU NIPDAU	Level-1-260C-UNLIM
THS4131IDRG4	ACTIVE	SOIC	D	8	2500	Green (RoHS & no Sb/Br)	CU NIPDAU	Level-1-260C-UNLIM

⁽¹⁾ The marketing status values are defined as follows:

ACTIVE: Product device recommended for new designs.

LIFEBUY: TI has announced that the device will be discontinued, and a lifetime-buy period is in effect.

NRND: Not recommended for new designs. Device is in production to support existing customers, but TI does not recommend using this part in a new design.

PREVIEW: Device has been announced but is not in production. Samples may or may not be available.

OBSOLETE: TI has discontinued the production of the device.

⁽²⁾ Eco Plan - The planned eco-friendly classification: Pb-Free (RoHS), Pb-Free (RoHS Exempt), or Green (RoHS & no Sb/Br) - please check <http://www.ti.com/productcontent> for the latest availability information and additional product content details.

TBD: The Pb-Free/Green conversion plan has not been defined.

Pb-Free (RoHS): TI's terms "Lead-Free" or "Pb-Free" mean semiconductor products that are compatible with the current RoHS requirements for all 6 substances, including the requirement that lead not exceed 0.1% by weight in homogeneous materials. Where designed to be soldered at high temperatures, TI Pb-Free products are suitable for use in specified lead-free processes.

Pb-Free (RoHS Exempt): This component has a RoHS exemption for either 1) lead-based flip-chip solder bumps used between the die and package, or 2) lead-based die adhesive used between the die and leadframe. The component is otherwise considered Pb-Free (RoHS compatible) as defined above.

Green (RoHS & no Sb/Br): TI defines "Green" to mean Pb-Free (RoHS compatible), and free of Bromine (Br) and Antimony (Sb) based flame retardants (Br or Sb do not exceed 0.1% by weight in homogeneous material)

⁽³⁾ MSL, Peak Temp. -- The Moisture Sensitivity Level rating according to the JEDEC industry standard classifications, and peak solder temperature.

Important Information and Disclaimer:The information provided on this page represents TI's knowledge and belief as of the date that it is provided. TI bases its knowledge and belief on information provided by third parties, and makes no representation or warranty as to the accuracy of such information. Efforts are underway to better integrate information from third parties. TI has taken and continues to take reasonable steps to provide representative and accurate information but may not have conducted destructive testing or chemical analysis on incoming materials and chemicals. TI and TI suppliers consider certain information to be proprietary, and thus CAS numbers and other limited information may not be available for release.

In no event shall TI's liability arising out of such information exceed the total purchase price of the TI part(s) at issue in this document sold by TI to Customer on an annual basis.

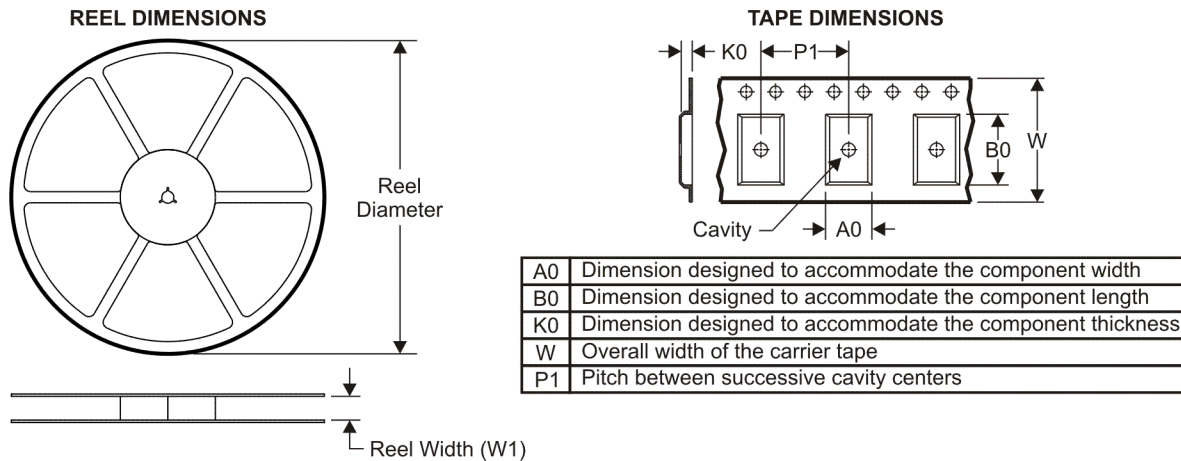
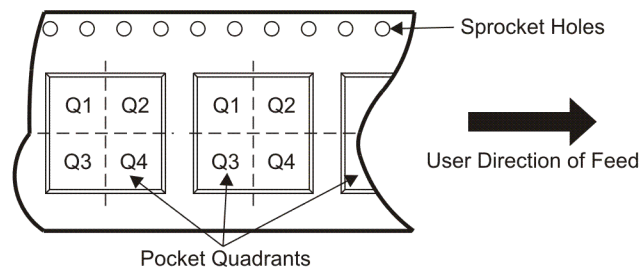
TAPE AND REEL INFORMATION

QUADRANT ASSIGNMENTS FOR PIN 1 ORIENTATION IN TAPE

*All dimensions are nominal

Device	Package Type	Package Drawing	Pins	SPQ	Reel Diameter (mm)	Reel Width W1 (mm)	A0 (mm)	B0 (mm)	K0 (mm)	P1 (mm)	W (mm)	Pin1 Quadrant
THS4130CDGKR	MSOP	DGK	8	2500	330.0	12.4	5.2	3.3	1.6	8.0	12.0	Q1
THS4130CDGNR	MSOP-Power PAD	DGN	8	2500	330.0	12.4	5.2	3.3	1.6	8.0	12.0	Q1
THS4130IDGKR	MSOP	DGK	8	2500	330.0	12.4	5.2	3.3	1.6	8.0	12.0	Q1
THS4130IDGNR	MSOP-Power PAD	DGN	8	2500	330.0	12.4	5.2	3.3	1.6	8.0	12.0	Q1
THS4130IDR	SOIC	D	8	2500	330.0	12.4	6.4	5.2	2.1	8.0	12.0	Q1
THS4131CDGKR	MSOP	DGK	8	2500	330.0	12.4	5.2	3.3	1.6	8.0	12.0	Q1
THS4131CDGNR	MSOP-Power PAD	DGN	8	2500	330.0	12.4	5.2	3.3	1.6	8.0	12.0	Q1
THS4131CDR	SOIC	D	8	2500	330.0	12.4	6.4	5.2	2.1	8.0	12.0	Q1
THS4131IDGKR	MSOP	DGK	8	2500	330.0	12.4	5.2	3.3	1.6	8.0	12.0	Q1
THS4131IDGNR	MSOP-Power PAD	DGN	8	2500	330.0	12.4	5.2	3.3	1.6	8.0	12.0	Q1
THS4131IDR	SOIC	D	8	2500	330.0	12.4	6.4	5.2	2.1	8.0	12.0	Q1

TAPE AND REEL BOX DIMENSIONS



*All dimensions are nominal

Device	Package Type	Package Drawing	Pins	SPQ	Length (mm)	Width (mm)	Height (mm)
THS4130CDGKR	MSOP	DGK	8	2500	338.1	340.5	21.1
THS4130CDGNR	MSOP-PowerPAD	DGN	8	2500	338.1	340.5	21.1
THS4130IDGKR	MSOP	DGK	8	2500	338.1	340.5	21.1
THS4130IDGNR	MSOP-PowerPAD	DGN	8	2500	338.1	340.5	21.1
THS4130IDR	SOIC	D	8	2500	346.0	346.0	29.0
THS4131CDGKR	MSOP	DGK	8	2500	338.1	340.5	21.1
THS4131CDGNR	MSOP-PowerPAD	DGN	8	2500	338.1	340.5	21.1
THS4131CDR	SOIC	D	8	2500	346.0	346.0	29.0
THS4131IDGKR	MSOP	DGK	8	2500	338.1	340.5	21.1
THS4131IDGNR	MSOP-PowerPAD	DGN	8	2500	338.1	340.5	21.1
THS4131IDR	SOIC	D	8	2500	346.0	346.0	29.0

MECHANICAL DATA

DGN (S-PDSO-G8)

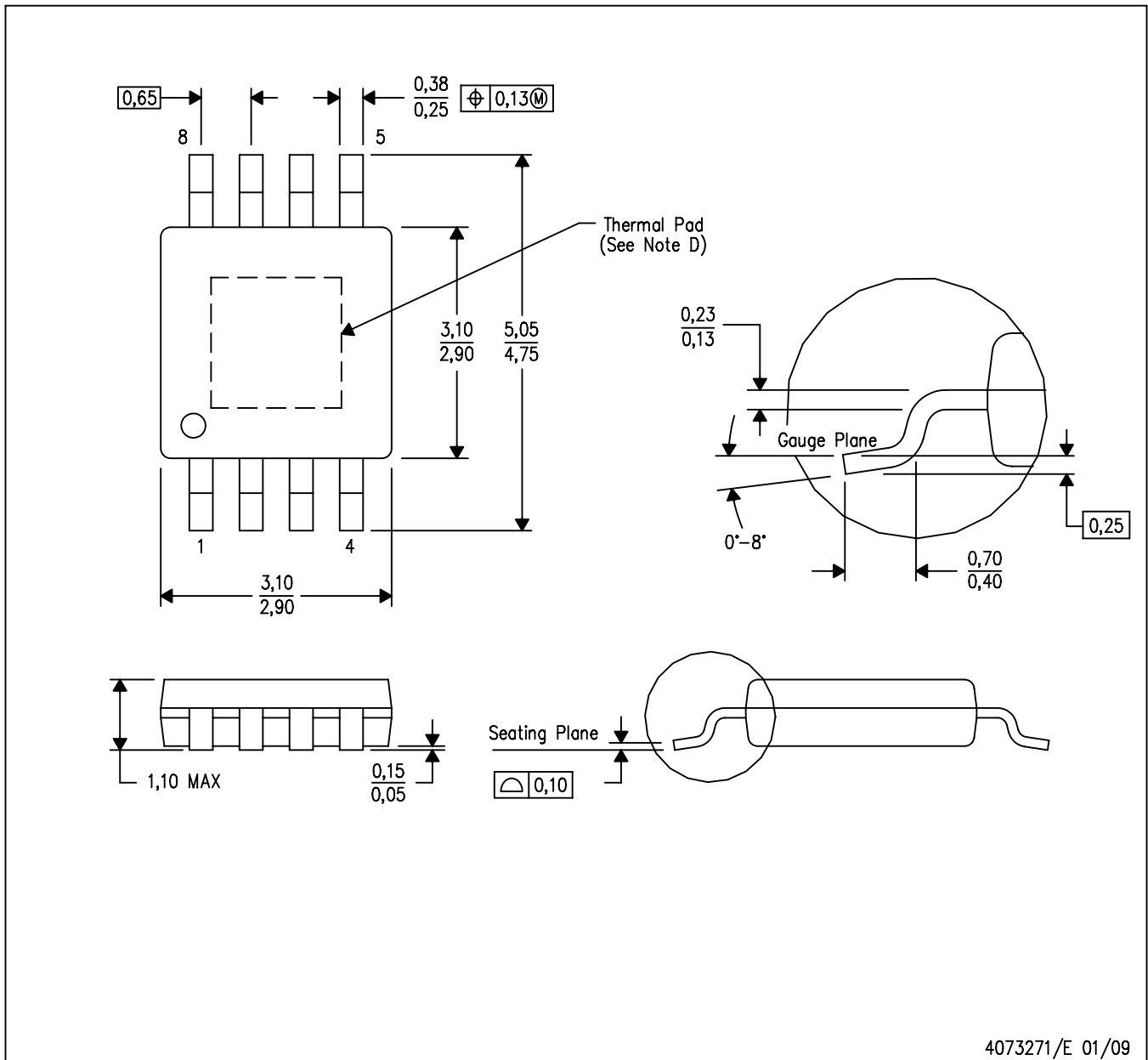
PowerPAD™ PLASTIC SMALL-OUTLINE PACKAGE



4073271/E 01/09

- NOTES:
- A. All linear dimensions are in millimeters.
 - B. This drawing is subject to change without notice.
 - C. Body dimensions do not include mold flash or protrusion.
 - D. This package is designed to be soldered to a thermal pad on the board. Refer to Technical Brief, PowerPAD Thermally Enhanced Package, Texas Instruments Literature No. SLMA002 for information regarding recommended board layout. This document is available at www.ti.com <<http://www.ti.com>>.
 - E. Falls within JEDEC MO-187 variation AA-T

PowerPAD is a trademark of Texas Instruments.

THERMAL INFORMATION

This PowerPAD™ package incorporates an exposed thermal pad that is designed to be attached to a printed circuit board (PCB). The thermal pad must be soldered directly to the PCB. After soldering, the PCB can be used as a heatsink. In addition, through the use of thermal vias, the thermal pad can be attached directly to the appropriate copper plane shown in the electrical schematic for the device, or alternatively, can be attached to a special heatsink structure designed into the PCB. This design optimizes the heat transfer from the integrated circuit (IC).

For additional information on the PowerPAD package and how to take advantage of its heat dissipating abilities, refer to Technical Brief, PowerPAD Thermally Enhanced Package, Texas Instruments Literature No. SLMA002 and Application Brief, PowerPAD Made Easy, Texas Instruments Literature No. SLMA004. Both documents are available at www.ti.com.

The exposed thermal pad dimensions for this package are shown in the following illustration.

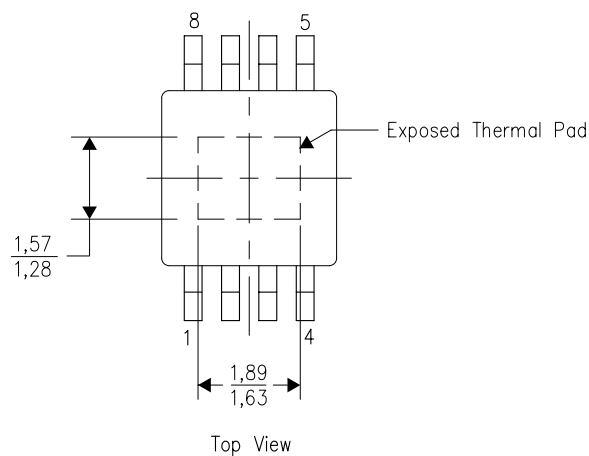

NOTE: All linear dimensions are in millimeters

Exposed Thermal Pad Dimensions

DGN (R-PDS0-G8) PowerPAD™

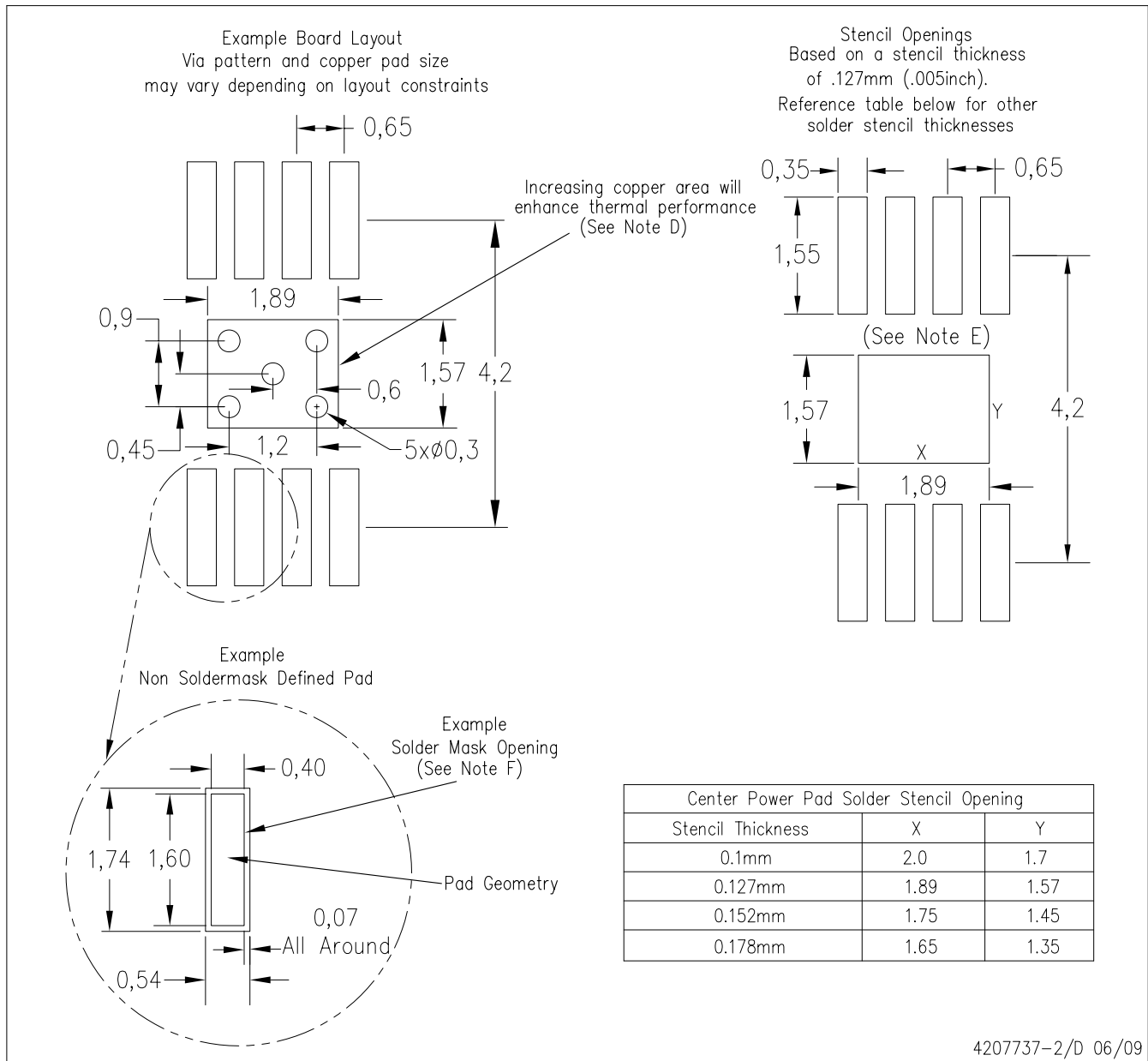

- NOTES:
- All linear dimensions are in millimeters.
 - This drawing is subject to change without notice.
 - Customers should place a note on the circuit board fabrication drawing not to alter the center solder mask defined pad.
 - This package is designed to be soldered to a thermal pad on the board. Refer to Technical Brief, PowerPad Thermally Enhanced Package, Texas Instruments Literature No. SLMA002, SLMA004, and also the Product Data Sheets for specific thermal information, via requirements, and recommended board layout. These documents are available at www.ti.com <<http://www.ti.com>>. Publication IPC-7351 is recommended for alternate designs.
 - Laser cutting apertures with trapezoidal walls and also rounding corners will offer better paste release. Customers should contact their board assembly site for stencil design recommendations. Example stencil design based on a 50% volumetric metal load solder paste. Refer to IPC-7525 for other stencil recommendations.
 - Customers should contact their board fabrication site for solder mask tolerances between and around signal pads.

D (R-PDSO-G8)

PLASTIC SMALL-OUTLINE PACKAGE

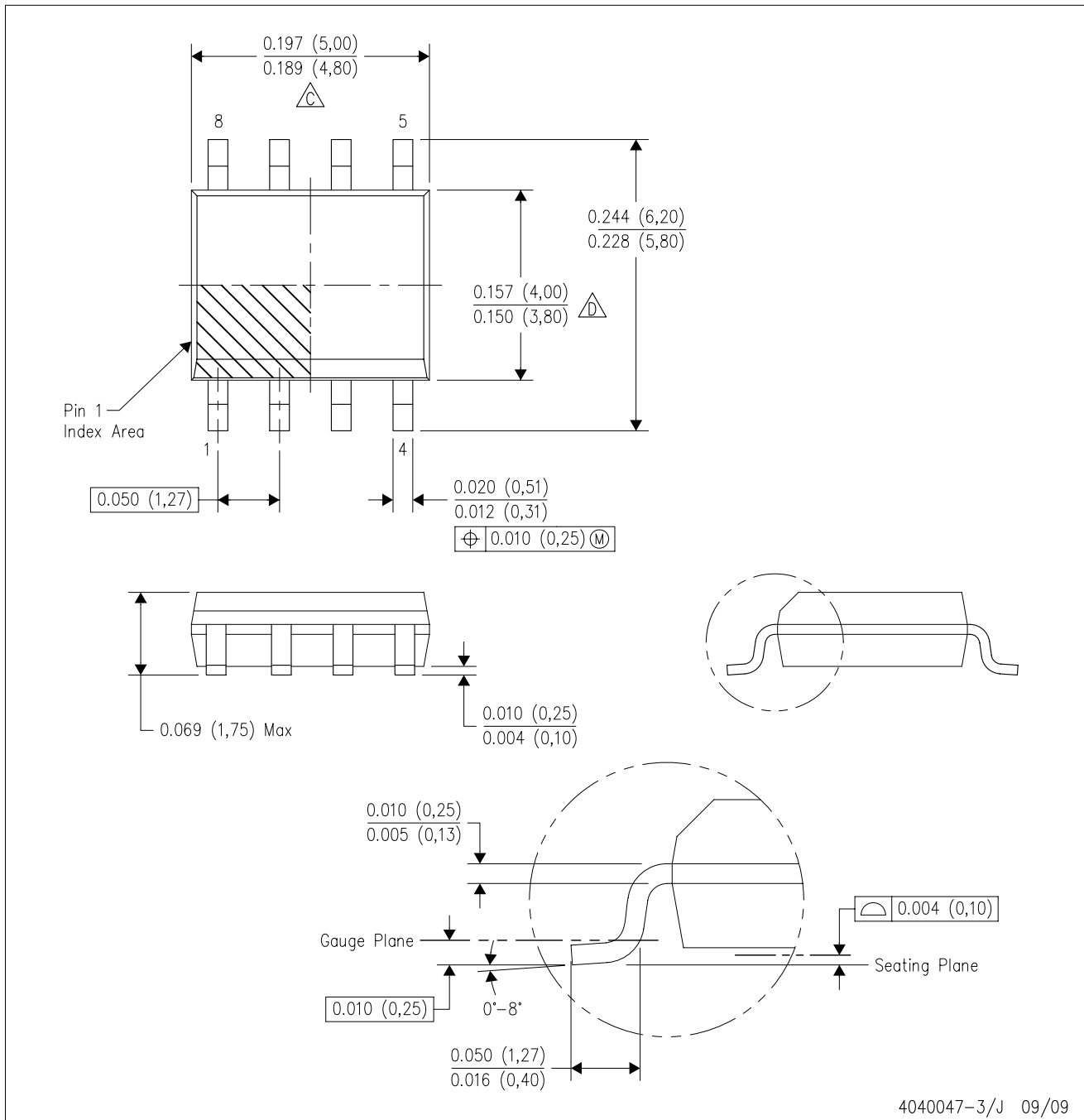

- NOTES:
- A. All linear dimensions are in inches (millimeters).
 - B. This drawing is subject to change without notice.
 - C. Body length does not include mold flash, protrusions, or gate burrs. Mold flash, protrusions, or gate burrs shall not exceed .006 (0,15) per end.
 - D. Body width does not include interlead flash. Interlead flash shall not exceed .017 (0,43) per side.
 - E. Reference JEDEC MS-012 variation AA.

IMPORTANT NOTICE

Texas Instruments Incorporated and its subsidiaries (TI) reserve the right to make corrections, modifications, enhancements, improvements, and other changes to its products and services at any time and to discontinue any product or service without notice. Customers should obtain the latest relevant information before placing orders and should verify that such information is current and complete. All products are sold subject to TI's terms and conditions of sale supplied at the time of order acknowledgment.

TI warrants performance of its hardware products to the specifications applicable at the time of sale in accordance with TI's standard warranty. Testing and other quality control techniques are used to the extent TI deems necessary to support this warranty. Except where mandated by government requirements, testing of all parameters of each product is not necessarily performed.

TI assumes no liability for applications assistance or customer product design. Customers are responsible for their products and applications using TI components. To minimize the risks associated with customer products and applications, customers should provide adequate design and operating safeguards.

TI does not warrant or represent that any license, either express or implied, is granted under any TI patent right, copyright, mask work right, or other TI intellectual property right relating to any combination, machine, or process in which TI products or services are used. Information published by TI regarding third-party products or services does not constitute a license from TI to use such products or services or a warranty or endorsement thereof. Use of such information may require a license from a third party under the patents or other intellectual property of the third party, or a license from TI under the patents or other intellectual property of TI.

Reproduction of TI information in TI data books or data sheets is permissible only if reproduction is without alteration and is accompanied by all associated warranties, conditions, limitations, and notices. Reproduction of this information with alteration is an unfair and deceptive business practice. TI is not responsible or liable for such altered documentation. Information of third parties may be subject to additional restrictions.

Resale of TI products or services with statements different from or beyond the parameters stated by TI for that product or service voids all express and any implied warranties for the associated TI product or service and is an unfair and deceptive business practice. TI is not responsible or liable for any such statements.

TI products are not authorized for use in safety-critical applications (such as life support) where a failure of the TI product would reasonably be expected to cause severe personal injury or death, unless officers of the parties have executed an agreement specifically governing such use. Buyers represent that they have all necessary expertise in the safety and regulatory ramifications of their applications, and acknowledge and agree that they are solely responsible for all legal, regulatory and safety-related requirements concerning their products and any use of TI products in such safety-critical applications, notwithstanding any applications-related information or support that may be provided by TI. Further, Buyers must fully indemnify TI and its representatives against any damages arising out of the use of TI products in such safety-critical applications.

TI products are neither designed nor intended for use in military/aerospace applications or environments unless the TI products are specifically designated by TI as military-grade or "enhanced plastic." Only products designated by TI as military-grade meet military specifications. Buyers acknowledge and agree that any such use of TI products which TI has not designated as military-grade is solely at the Buyer's risk, and that they are solely responsible for compliance with all legal and regulatory requirements in connection with such use.

TI products are neither designed nor intended for use in automotive applications or environments unless the specific TI products are designated by TI as compliant with ISO/TS 16949 requirements. Buyers acknowledge and agree that, if they use any non-designated products in automotive applications, TI will not be responsible for any failure to meet such requirements.

Following are URLs where you can obtain information on other Texas Instruments products and application solutions:

Products		Applications	
Amplifiers	amplifier.ti.com	Audio	www.ti.com/audio
Data Converters	dataconverter.ti.com	Automotive	www.ti.com/automotive
DLP® Products	www.dlp.com	Communications and Telecom	www.ti.com/communications
DSP	dsp.ti.com	Computers and Peripherals	www.ti.com/computers
Clocks and Timers	www.ti.com/clocks	Consumer Electronics	www.ti.com/consumer-apps
Interface	interface.ti.com	Energy	www.ti.com/energy
Logic	logic.ti.com	Industrial	www.ti.com/industrial
Power Mgmt	power.ti.com	Medical	www.ti.com/medical
Microcontrollers	microcontroller.ti.com	Security	www.ti.com/security
RFID	www.ti-rfid.com	Space, Avionics & Defense	www.ti.com/space-avionics-defense
RF/IF and ZigBee® Solutions	www.ti.com/lprf	Video and Imaging	www.ti.com/video
		Wireless	www.ti.com/wireless-apps

Mailing Address: Texas Instruments, Post Office Box 655303, Dallas, Texas 75265
Copyright © 2010, Texas Instruments Incorporated