

Distributed by:

JAMECO[®]
ELECTRONICS

www.Jameco.com ♦ 1-800-831-4242

The content and copyrights of the attached
material are the property of its owner.

Jameco Part Number 1059750



HIGH-VOLTAGE, LOW-DISTORTION, CURRENT-FEEDBACK OPERATIONAL AMPLIFIERS

FEATURES

- **Low Distortion**
 - 77 dBc HD2 at 10 MHz, $R_L = 1\text{ k}\Omega$
 - 69 dBc HD3 at 10 MHz, $R_L = 1\text{ k}\Omega$
- **Low Noise**
 - 14 pA/ $\sqrt{\text{Hz}}$ Noninverting Current Noise
 - 17 pA/ $\sqrt{\text{Hz}}$ Inverting Current Noise
 - 2 nV/ $\sqrt{\text{Hz}}$ Voltage Noise
- **High Slew Rate: 7300 V/ μs ($G = 5$, $V_O = 20\text{ V}_{PP}$)**
- **Wide Bandwidth: 210 MHz ($G = 2$, $R_L = 100\ \Omega$)**
- **High Output Current Drive: $\pm 250\text{ mA}$**
- **Wide Supply Range: $\pm 5\text{ V}$ to $\pm 15\text{ V}$**
- **Power-Down Feature: (THS3095 Only)**

APPLICATIONS

- High-Voltage Arbitrary Waveform
- Power FET Driver
- Pin Driver
- VDSL Line Driver

DESCRIPTION

The THS3091 and THS3095 are high-voltage, low-distortion, high-speed, current-feedback amplifiers designed to operate over a wide supply range of $\pm 5\text{ V}$ to $\pm 15\text{ V}$ for applications requiring large, linear output signals such as Pin, Power FET, and VDSL line drivers.

The THS3095 features a power-down pin ($\overline{\text{PD}}$) that puts the amplifier in low power standby mode, and lowers the quiescent current from 9.5 mA to 500 μA .

The wide supply range combined with total harmonic distortion as low as -69 dBc at 10 MHz, in addition, to the high slew rate of 7300 V/ μs makes the THS3091/5 ideally suited for high-voltage arbitrary waveform driver applications. Moreover, having the ability to handle large voltage swings driving into high-resistance and high-capacitance loads while maintaining good settling time performance makes the devices ideal for Pin driver and PowerFET driver applications.

The THS3091 and THS3095 are offered in an 8-pin SOIC (D), and the 8-pin SOIC (DDA) packages with PowerPAD™.

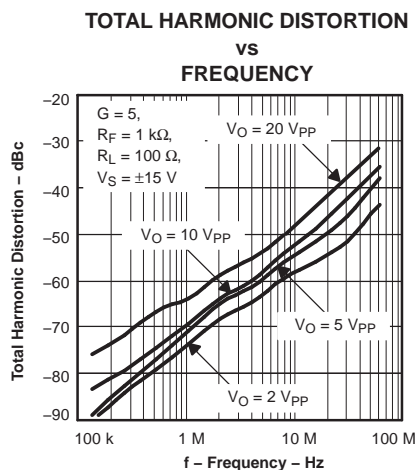

TYPICAL ARBITRARY WAVEFORM GENERATOR OUTPUT DRIVE CIRCUIT

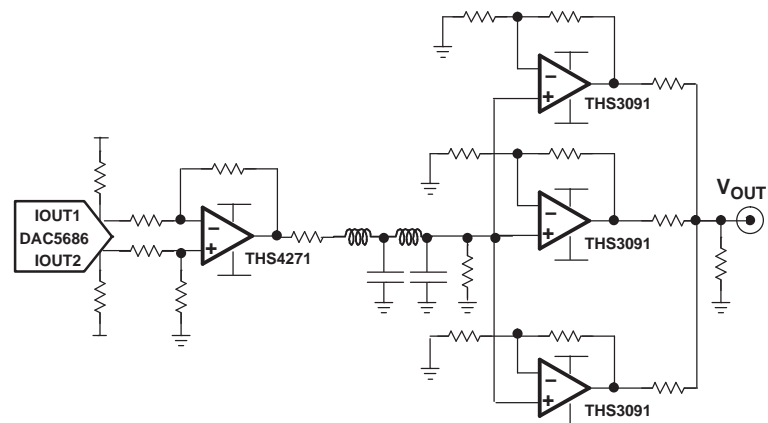

Please be aware that an important notice concerning availability, standard warranty, and use in critical applications of Texas Instruments semiconductor products and disclaimers thereto appears at the end of this data sheet.

PowerPAD is a trademark of Texas Instruments.



These devices have limited built-in ESD protection. The leads should be shorted together or the device placed in conductive foam during storage or handling to prevent electrostatic damage to the MOS gates.

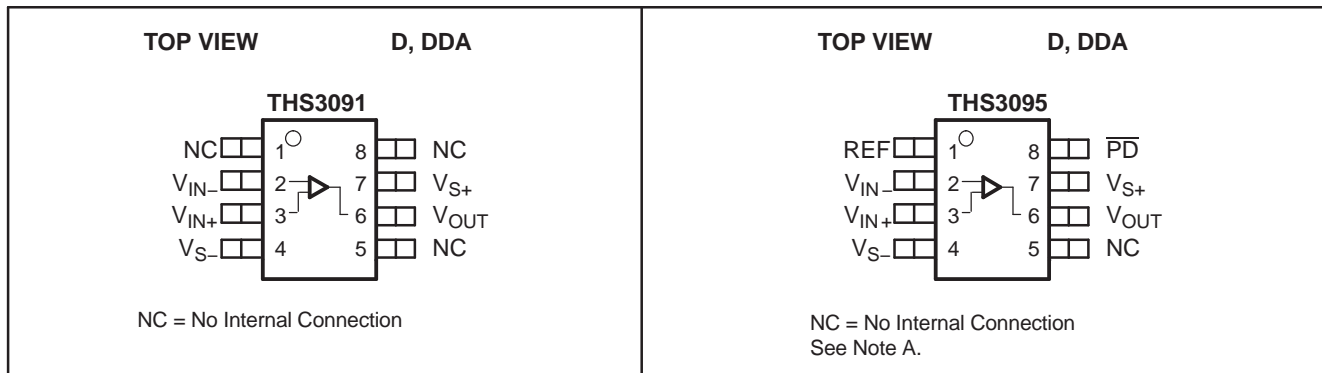

Note A: The devices with the power-down option defaults to the ON state if no signal is applied to the $\overline{\text{PD}}$ pin. Additionally, the REF pin functional range is from V_{S-} to $(V_{S+} - 4 \text{ V})$.

ORDERING INFORMATION

PART NUMBER	PACKAGE TYPE	TRANSPORT MEDIA, QUANTITY
THS3091D	SOIC-8	Rails, 75
THS3091DR		Tape and Reel, 2500
THS3091DDA	SOIC-8-PP ⁽¹⁾	Rails, 75
THS3091DDAR		Tape and Reel, 2500
<i>Power-down</i>		
THS3095D	SOIC-8	Rails, 75
THS3095DR		Tape and Reel, 2500
THS3095DDA	SOIC-8-PP ⁽¹⁾	Rails, 75
THS3095DDAR		Tape and Reel, 2500

(1) The PowerPAD is electrically isolated from all other pins.

DISSIPATION RATING TABLE

PACKAGE	Θ_{JC} (°C/W)	Θ_{JA} (°C/W) ⁽¹⁾	POWER RATING ⁽²⁾ $T_{\text{J}} = 125^{\circ}\text{C}$	
			$T_{\text{A}} = 25^{\circ}\text{C}$	$T_{\text{A}} = 85^{\circ}\text{C}$
D-8	38.3	97.5	1.02 W	410 mW
DDA-8 ⁽³⁾	9.2	45.8	2.18 W	873 mW

- (1) This data was taken using the JEDEC standard High-K test PCB.
- (2) Power rating is determined with a junction temperature of 125°C. This is the point where distortion starts to substantially increase. Thermal management of the final PCB should strive to keep the junction temperature at or below 125°C for best performance and long-term reliability.
- (3) The THS3091 and THS3095 may incorporate a PowerPAD™ on the underside of the chip. This acts as a heatsink and must be connected to a thermally dissipating plane for proper power dissipation. Failure to do so may result in exceeding the maximum junction temperature which could permanently damage the device. See TI Technical Brief SLMA002 for more information about utilizing the PowerPAD™ thermally enhanced package.

RECOMMENDED OPERATING CONDITIONS

		MIN	MAX	UNIT
Supply voltage	Dual supply	±5	±15	V
	Single supply	10	30	
T_A	Operating free-air temperature	-40	85	°C

ABSOLUTE MAXIMUM RATINGS

over operating free-air temperature (unless otherwise noted)⁽¹⁾

		UNIT
V_{S-} to V_{S+}	Supply voltage	33 V
V_I	Input voltage	± V_S
V_{ID}	Differential input voltage	± 4 V
I_O	Output current	350 mA
Continuous power dissipation		See Dissipation Ratings Table
T_J	Maximum junction temperature,	150°C
$T_J^{(2)}$	Maximum junction temperature, continuous operation, long-term reliability	125°C
T_{stg}	Storage temperature	-65°C to 150°C
Lead temperature ⁽³⁾		
ESD ratings	HBM	2000
	CDM	1500
	MM	150

- (1) The absolute maximum ratings under any condition is limited by the constraints of the silicon process. Stresses above these ratings may cause permanent damage. Exposure to absolute maximum conditions for extended periods may degrade device reliability. These are stress ratings only, and functional operation of the device at these or any other conditions beyond those specified is not implied.
- (2) The maximum junction temperature for continuous operation is limited by package constraints. Operation above this temperature may result in reduced reliability and/or lifetime of the device.
- (3) See the MSL/Reflow Rating information provided with the material, or see TI's web site at www.ti.com for the latest information.

ELECTRICAL CHARACTERISTICS

$V_S = \pm 15\text{ V}$, $R_F = 1.21\text{ k}\Omega$, $R_L = 100\ \Omega$, and $G = 2$ (unless otherwise noted)

PARAMETER	TEST CONDITIONS	TYP	OVER TEMPERATURE				UNIT	MIN/TYP/ MAX
		25°C	25°C	0°C to 70°C	-40°C to 85°C			
AC PERFORMANCE								
Small-signal bandwidth, -3 dB	$G = 1$, $R_F = 1.78\text{ k}\Omega$, $V_O = 200\text{ mV}_{PP}$	235				MHz	TYP	
	$G = 2$, $R_F = 1.21\text{ k}\Omega$, $V_O = 200\text{ mV}_{PP}$	210						
	$G = 5$, $R_F = 1\text{ k}\Omega$, $V_O = 200\text{ mV}_{PP}$	190						
	$G = 10$, $R_F = 866\ \Omega$, $V_O = 200\text{ mV}_{PP}$	180						
0.1-dB bandwidth flatness	$G = 2$, $R_F = 1.21\text{ k}\Omega$, $V_O = 200\text{ mV}_{PP}$	95						
Large-signal bandwidth	$G = 5$, $R_F = 1\text{ k}\Omega$, $V_O = 4\text{ V}_{PP}$	135						
Slew rate (25% to 75% level)	$G = 2$, $V_O = 10\text{-V step}$, $R_F = 1.21\text{ k}\Omega$	5000				V/ μ s	TYP	
	$G = 5$, $V_O = 20\text{-V step}$, $R_F = 1\text{ k}\Omega$	7300						
Rise and fall time	$G = 2$, $V_O = 5\text{-V}_{PP}$, $R_F = 1.21\text{ k}\Omega$	5				ns	TYP	
Settling time to 0.1%	$G = -2$, $V_O = 2\text{ V}_{PP}$ step	42				ns	TYP	
Settling time to 0.01%	$G = -2$, $V_O = 2\text{ V}_{PP}$ step	72						
Harmonic distortion								
2nd Harmonic distortion	$G = 2$, $R_F = 1.21\text{ k}\Omega$, $V_O = 2\text{ V}_{PP}$, $f = 10\text{ MHz}$	$R_L = 100\ \Omega$	66			dBc	TYP	
		$R_L = 1\text{ k}\Omega$	77					
3rd Harmonic distortion		$R_L = 100\ \Omega$	74					
		$R_L = 1\text{ k}\Omega$	69					
Input voltage noise	$f > 10\text{ kHz}$	2				nV / $\sqrt{\text{Hz}}$	TYP	
Noninverting input current noise	$f > 10\text{ kHz}$	14				pA / $\sqrt{\text{Hz}}$	TYP	
Inverting input current noise	$f > 10\text{ kHz}$	17				pA / $\sqrt{\text{Hz}}$	TYP	
Differential gain	$G = 2$, $R_L = 150\ \Omega$, $R_F = 1.21\text{ k}\Omega$	NTSC	0.013%			TYP		
		PAL	0.011%					
Differential phase		NTSC	0.020°					
		PAL	0.026°					
DC PERFORMANCE								
Transimpedance	$V_O = \pm 7.5\text{ V}$, Gain = 1	850	350	300	300	k Ω	MIN	
Input offset voltage	$V_{CM} = 0\text{ V}$	0.9	3	4	4	mV	MAX	
Average offset voltage drift					± 10	± 10	$\mu\text{V}/^\circ\text{C}$	TYP
Noninverting input bias current	$V_{CM} = 0\text{ V}$	4	15	20	20	μA	MAX	
Average bias current drift					± 20	± 20	nA/ $^\circ\text{C}$	TYP
Inverting input bias current	$V_{CM} = 0\text{ V}$	3.5	15	20	20	μA	MAX	
Average bias current drift					± 20	± 20	nA/ $^\circ\text{C}$	TYP
Input offset current	$V_{CM} = 0\text{ V}$	1.7	10	15	15	μA	MAX	
Average offset current drift					± 20	± 20	nA/ $^\circ\text{C}$	TYP
INPUT CHARACTERISTICS								
Common-mode input range		± 13.6	± 13.3	± 13	± 13	V	MIN	
Common-mode rejection ratio	$V_{CM} = \pm 10\text{ V}$	78	68	65	65	dB	MIN	
Noninverting input resistance		1.3				M Ω	TYP	
Noninverting input capacitance		0.1				pF	TYP	
Inverting input resistance		30				Ω	TYP	
Inverting input capacitance		1.4				pF	TYP	

ELECTRICAL CHARACTERISTICS (continued)

$V_S = \pm 15\text{ V}$, $R_F = 1.21\text{ k}\Omega$, $R_L = 100\ \Omega$, and $G = 2$ (unless otherwise noted)

PARAMETER	TEST CONDITIONS	TYP	OVER TEMPERATURE				UNIT	MIN/TYP/ MAX
		25°C	25°C	0°C to 70°C	-40°C to 85°C			
OUTPUT CHARACTERISTICS								
Output voltage swing	$R_L = 1\text{ k}\Omega$	± 13.2	± 12.8	± 12.5	± 12.5	V	MIN	
	$R_L = 100\ \Omega$	± 12.5	± 12.1	± 11.8	± 11.8			
Output current (sourcing)	$R_L = 40\ \Omega$	280	225	200	200	mA	MIN	
Output current (sinking)	$R_L = 40\ \Omega$	250	200	175	175	mA	MIN	
Output impedance	$f = 1\text{ MHz}$, Closed loop	0.06				Ω	TYP	
POWER SUPPLY								
Specified operating voltage		± 15	± 16	± 16	± 16	V	MAX	
Maximum quiescent current		9.5	10.5	11	11	mA	MAX	
Minimum quiescent current		9.5	8.5	8	8	mA	MIN	
Power supply rejection (+PSRR)	$V_{S+} = 15.5\text{ V}$ to 14.5 V , $V_{S-} = 15\text{ V}$	75	70	65	65	dB	MIN	
Power supply rejection (-PSRR)	$V_{S+} = 15\text{ V}$, $V_{S-} = -15.5\text{ V}$ to -14.5 V	73	68	65	65	dB	MIN	
POWER-DOWN CHARACTERISTICS (THS3095 ONLY)								
REF voltage range ⁽¹⁾		$V_{S+} - 4$				V	MAX	
		V_{S-}				V	MIN	
Power-down voltage level ⁽¹⁾	Enable	$\overline{PD} \geq \text{REF} + 2$				V	MIN	
	Disable	$\overline{PD} \leq \text{REF} + 0.8$				V	MAX	
Power-down quiescent current	$\overline{PD} = 0\text{ V}$	500	700	800	800	μA	MAX	
V_{PD} quiescent current	$V_{PD} = 0\text{ V}$, $\text{REF} = 0\text{ V}$,	11	15	20	20	μA	MAX	
	$V_{PD} = 3.3\text{ V}$, $\text{REF} = 0\text{ V}$	11	15	20	20			
Turnon time delay	90% of final value	60				μs	TYP	
Turnoff time delay	10% of final value	150						

(1) For detailed information on the behavior of the power-down circuit, see the *power-down functionality* and *power-down reference* sections in the Application Information section of this data sheet.

ELECTRICAL CHARACTERISTICS

$V_S = \pm 5\text{ V}$, $R_F = 1.15\text{ k}\Omega$, $R_L = 100\ \Omega$, and $G = 2$ (unless otherwise noted)

PARAMETER	TEST CONDITIONS	TYP	OVER TEMPERATURE				UNIT	MIN/TYP/ MAX
		25°C	25°C	0°C to 70°C	-40°C to 85°C			
AC PERFORMANCE								
Small-signal bandwidth, -3 dB	$G = 1$, $R_F = 1.78\text{ k}\Omega$, $V_O = 200\text{ mV}_{PP}$	190					MHz	TYP
	$G = 2$, $R_F = 1.15\text{ k}\Omega$, $V_O = 200\text{ mV}_{PP}$	180						
	$G = 5$, $R_F = 1\text{ k}\Omega$, $V_O = 200\text{ mV}_{PP}$	160						
	$G = 10$, $R_F = 866\ \Omega$, $V_O = 200\text{ mV}_{PP}$	150						
0.1-dB bandwidth flatness	$G = 2$, $R_F = 1.15\text{ k}\Omega$, $V_O = 200\text{ mV}_{PP}$	65						
Large-signal bandwidth	$G = 2$, $R_F = 1.15\text{ k}\Omega$, $V_O = 4\text{ V}_{PP}$	160						
Slew rate (25% to 75% level)	$G = 2$, $V_O = 5\text{-V step}$, $R_F = 1.21\text{ k}\Omega$	1400					V/ μ s	TYP
	$G = 5$, $V_O = 5\text{-V step}$, $R_F = 1\text{ k}\Omega$	1900						
Rise and fall time	$G = 2$, $V_O = 5\text{-V step}$, $R_F = 1.21\text{ k}\Omega$	5					ns	TYP
Settling time to 0.1%	$G = -2$, $V_O = 2\text{ V}_{PP}$ step	35					ns	TYP
Settling time to 0.01%	$G = -2$, $V_O = 2\text{ V}_{PP}$ step	73						
Harmonic distortion								
2nd Harmonic distortion	$G = 2$, $R_F = 1.15\text{ k}\Omega$, $V_O = 2\text{ V}_{PP}$, $f = 10\text{ MHz}$	$R_L = 100\ \Omega$	77				dBc	TYP
		$R_L = 1\text{ k}\Omega$	73					
3rd Harmonic distortion		$R_L = 100\ \Omega$	70					
		$R_L = 1\text{ k}\Omega$	68					
Input voltage noise	$f > 10\text{ kHz}$	2					nV / $\sqrt{\text{Hz}}$	TYP
Noninverting input current noise	$f > 10\text{ kHz}$	14					pA / $\sqrt{\text{Hz}}$	TYP
Inverting input current noise	$f > 10\text{ kHz}$	17					pA / $\sqrt{\text{Hz}}$	TYP
Differential gain	$G = 2$, $R_L = 150\ \Omega$, $R_F = 1.15\text{ k}\Omega$	NTSC	0.027%				TYP	
		PAL	0.025%					
Differential phase		NTSC	0.04°					
		PAL	0.05°					
DC PERFORMANCE								
Transimpedance	$V_O = \pm 2.5\text{ V}$, Gain = 1	700	250	200	200		k Ω	MIN
Input offset voltage	$V_{CM} = 0\text{ V}$	0.3	2	3	3		mV	MAX
Average offset voltage drift					± 10	± 10		$\mu\text{V}/^\circ\text{C}$
Noninverting input bias current	$V_{CM} = 0\text{ V}$	2	15	20	20		μA	MAX
Average bias current drift					± 20	± 20		nA/ $^\circ\text{C}$
Inverting input bias current	$V_{CM} = 0\text{ V}$	5	15	20	20		μA	MAX
Average bias current drift					± 20	± 20		nA/ $^\circ\text{C}$
Input offset current	$V_{CM} = 0\text{ V}$	1	10	15	15		μA	MAX
Average offset current drift					± 20	± 20		nA/ $^\circ\text{C}$
INPUT CHARACTERISTICS								
Common-mode input range		± 3.6	± 3.3	± 3	± 3		V	MIN
Common-mode rejection ratio	$V_{CM} = \pm 2.0\text{ V}$, $V_O = 0\text{ V}$	66	60	57	57		dB	MIN
Noninverting input resistance		1.1					M Ω	TYP
Noninverting input capacitance		1.2					pF	TYP
Inverting input resistance		32					Ω	TYP
Inverting input capacitance		1.5					pF	TYP

ELECTRICAL CHARACTERISTICS (continued)

$V_S = \pm 5\text{ V}$, $R_F = 1.15\text{ k}\Omega$, $R_L = 100\ \Omega$, and $G = 2$ (unless otherwise noted)

PARAMETER	TEST CONDITIONS	TYP	OVER TEMPERATURE				UNIT	MIN/TYP/ MAX
		25°C	25°C	0°C to 70°C	-40°C to 85°C			
OUTPUT CHARACTERISTICS								
Output voltage swing	$R_L = 1\text{ k}\Omega$	± 3.4	± 3.1	± 2.8	± 2.8	V	MIN	
	$R_L = 100\ \Omega$	± 3.1	± 2.7	± 2.5	± 2.5			
Output current (sourcing)	$R_L = 40\ \Omega$	200	160	140	140	mA	MIN	
Output current (sinking)	$R_L = 40\ \Omega$	180	150	125	125	mA	MIN	
Output impedance	$f = 1\text{ MHz}$, Closed loop	0.09				Ω	TYP	
POWER SUPPLY								
Specified operating voltage		± 5	± 4.5	± 4.5	± 4.5	V	MAX	
Maximum quiescent current		8.2	9	9.5	9.5	mA	MAX	
Minimum quiescent current		8.2	7	6.5	6.5	mA	MIN	
Power supply rejection (+PSRR)	$V_{S+} = 5.5\text{ V}$ to 4.5 V , $V_{S-} = 5\text{ V}$	73	68	63	63	dB	MIN	
Power supply rejection (-PSRR)	$V_{S+} = 5\text{ V}$, $V_{S-} = -4.5\text{ V}$ to -5.5 V	71	65	60	60	dB	MIN	
POWER-DOWN CHARACTERISTICS (THS3095 ONLY)								
REF voltage range ⁽¹⁾		$V_{S+} - 4$				V	MAX	
		V_{S-}				V	MIN	
Power-down voltage level ⁽¹⁾	Enable	$\overline{PD} \geq \text{REF} + 2$				V	MIN	
	Disable	$\overline{PD} \leq \text{REF} + 0.8$				V	MAX	
Power-down quiescent current	$\overline{PD} = 0\text{ V}$	300	500	600	600	μA	MAX	
V_{PD} quiescent current	$V_{PD} = 0\text{ V}$, $\text{REF} = 0\text{ V}$,	11	15	20	20	μA	MAX	
	$V_{PD} = 3.3\text{ V}$, $\text{REF} = 0\text{ V}$	11	15	20	20			
Turnon time delay	90% of final value	60				μs	TYP	
Turnoff time delay	10% of final value	150						

(1) For detailed information on the behavior of the power-down circuit, see the *power-down functionality* and *power-down reference* sections in the Application Information section of this data sheet.

TYPICAL CHARACTERISTICS

TABLE OF GRAPHS

±15-V GRAPHS		FIGURE
Noninverting small-signal frequency response		1, 2
Inverting small-signal frequency response		3
0.1-dB gain flatness frequency response		4
Noninverting large-signal frequency response		5
Inverting large-signal frequency response		6
Capacitive load frequency response		7
Recommended R_{ISO}	vs Capacitive load	8
2nd Harmonic distortion	vs Frequency	9, 11
3rd Harmonic distortion	vs Frequency	10, 12
2nd Harmonic distortion	vs Frequency	13
3rd Harmonic distortion	vs Frequency	14
Harmonic distortion	vs Output voltage swing	15, 16
Slew rate	vs Output voltage step	17, 18, 19
Noise	vs Frequency	20
Settling time		21, 22
Quiescent current	vs Supply voltage	23
Quiescent current	vs Frequency	24
Output voltage	vs Load resistance	25
Input bias and offset current	vs Case temperature	26
Input offset voltage	vs Case temperature	27
Transimpedance	vs Frequency	28
Rejection ratio	vs Frequency	29
Noninverting small-signal transient response		30
Inverting large-signal transient response		31, 32
Overdrive recovery time		33
Differential gain	vs Number of loads	34
Differential phase	vs Number of loads	35
Closed-loop output impedance	vs Frequency	36
Power-down quiescent current	vs Supply voltage	37
Turnon and turnoff time delay		38

TABLE OF GRAPHS (Continued)

±5-V GRAPHS		FIGURE
Noninverting small-signal frequency response		39
Inverting small-signal frequency response		40
0.1-dB gain flatness frequency response		41
Noninverting large-signal frequency response		42
Inverting large-signal frequency response		43
Settling time		44
2nd Harmonic distortion	vs Frequency	45, 47
3rd Harmonic distortion	vs Frequency	46, 48
Harmonic distortion	vs Output voltage swing	49, 50
Slew rate	vs Output voltage step	51, 52, 53
Quiescent current	vs Frequency	54
Output voltage	vs Load resistance	55
Input bias and offset current	vs Case temperature	56
Overdrive recovery time		57
Rejection ratio	vs Frequency	58

TYPICAL CHARACTERISTICS (± 15 V)

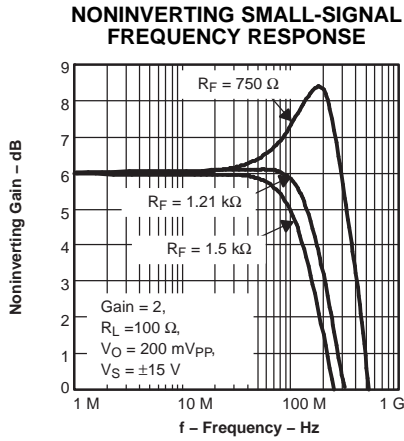

Figure 1.

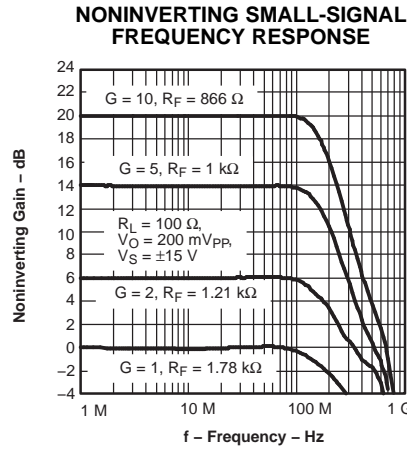

Figure 2.

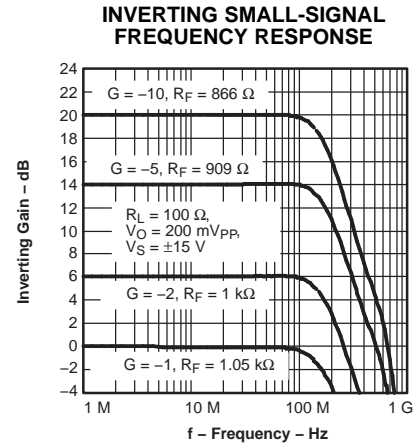

Figure 3.

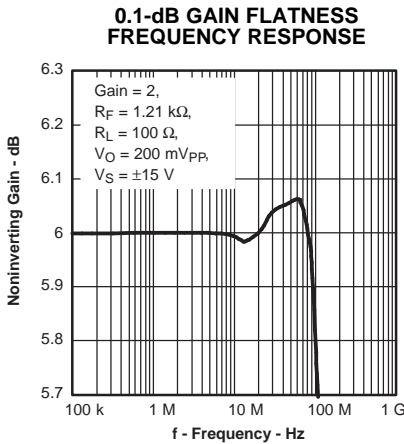

Figure 4.

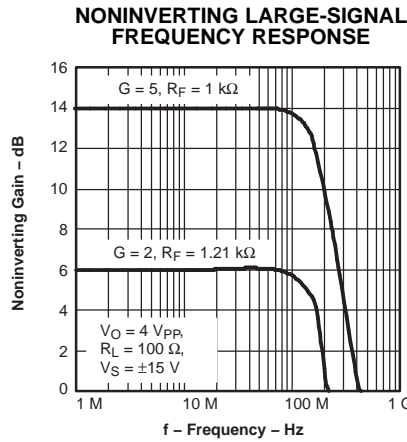

Figure 5.

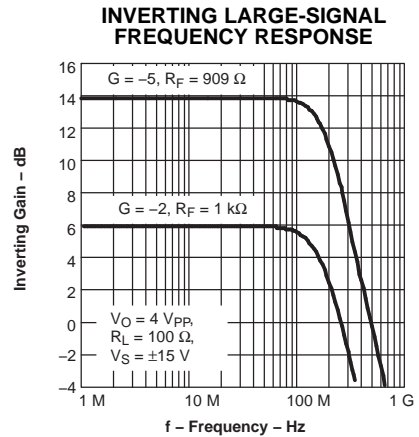

Figure 6.

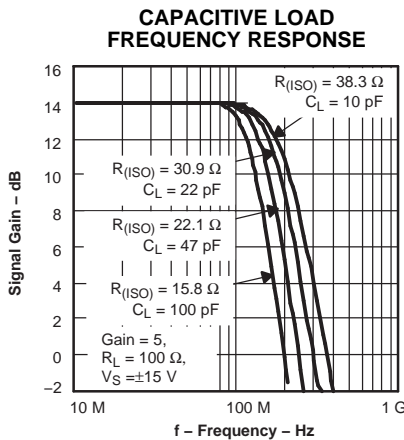

Figure 7.

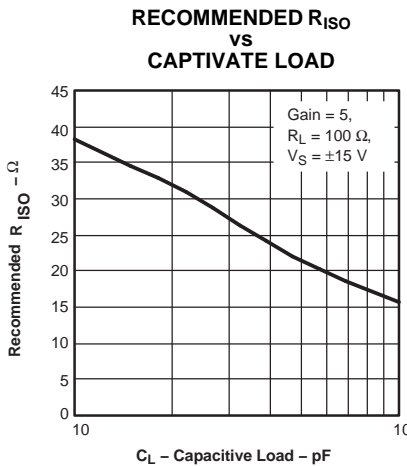

Figure 8.

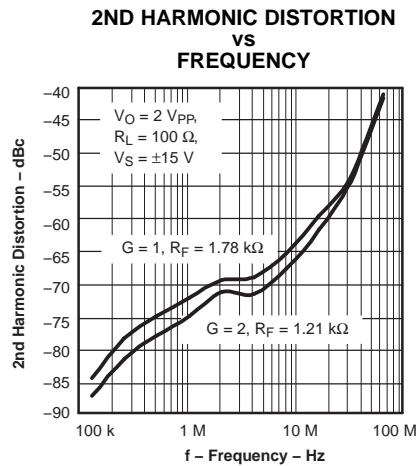

Figure 9.

TYPICAL CHARACTERISTICS (± 15 V) (continued)

3RD HARMONIC DISTORTION
VS
FREQUENCY

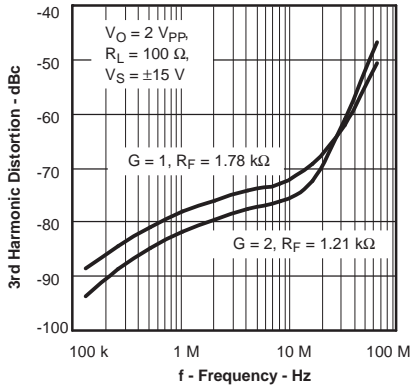

Figure 10.

2ND HARMONIC DISTORTION
VS
FREQUENCY

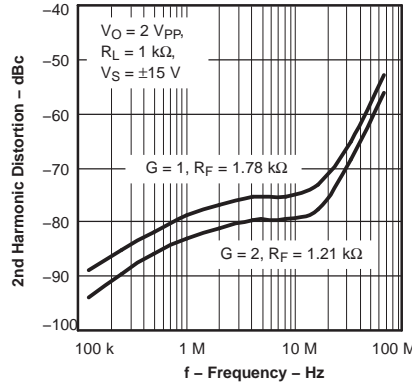

Figure 11.

3RD HARMONIC DISTORTION
VS
FREQUENCY

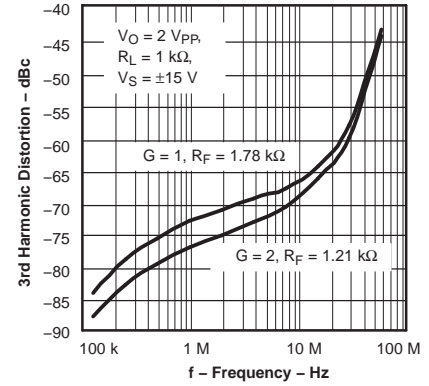

Figure 12.

2ND HARMONIC DISTORTION
VS
FREQUENCY

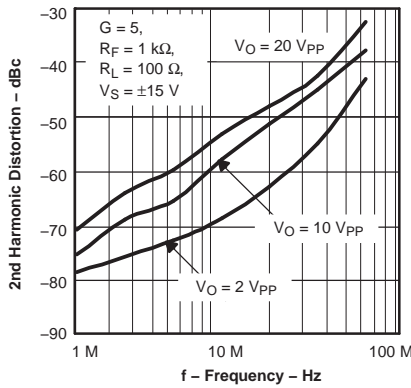

Figure 13.

3RD HARMONIC DISTORTION
VS
FREQUENCY

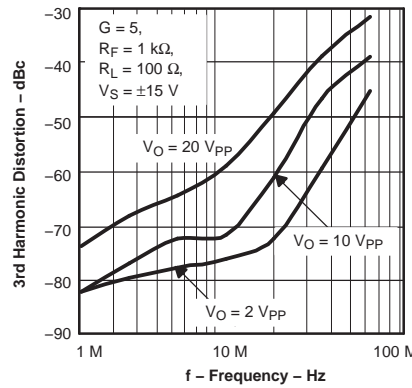

Figure 14.

HARMONIC DISTORTION
VS
OUTPUT VOLTAGE SWING

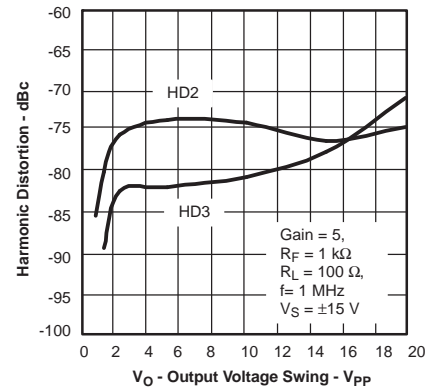

Figure 15.

HARMONIC DISTORTION
VS
OUTPUT VOLTAGE SWING

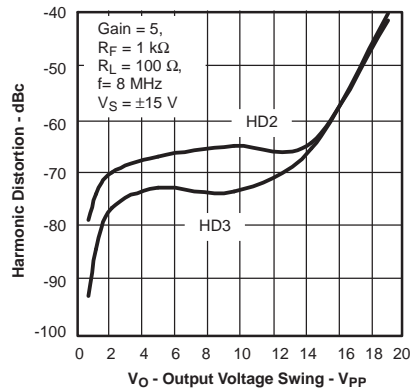

Figure 16.

SLEW RATE
VS
OUTPUT VOLTAGE STEP

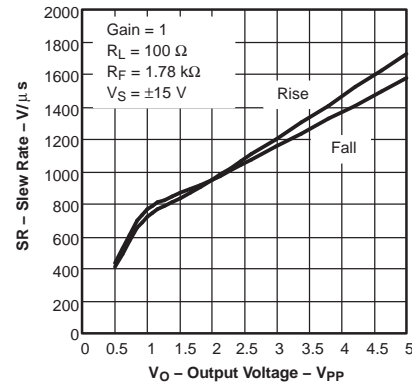

Figure 17.

SLEW RATE
VS
OUTPUT VOLTAGE STEP

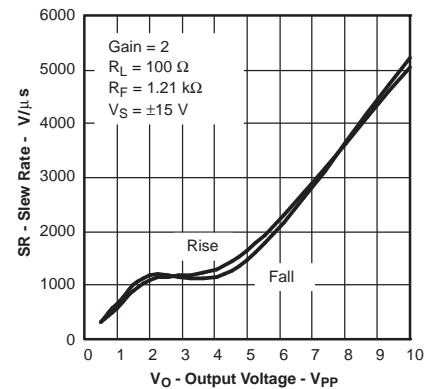

Figure 18.

TYPICAL CHARACTERISTICS (±15 V) (continued)

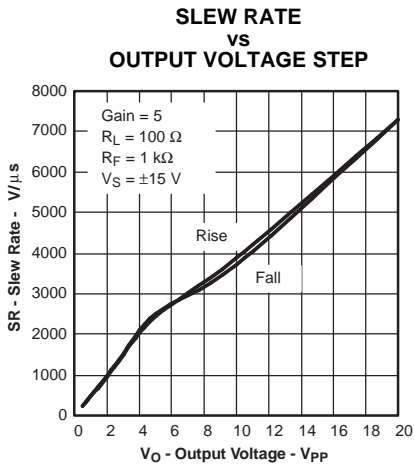

Figure 19.

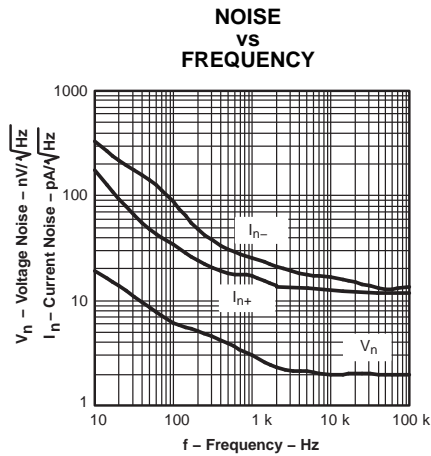

Figure 20.

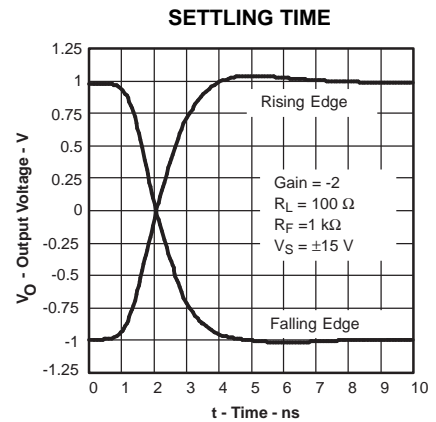

Figure 21.

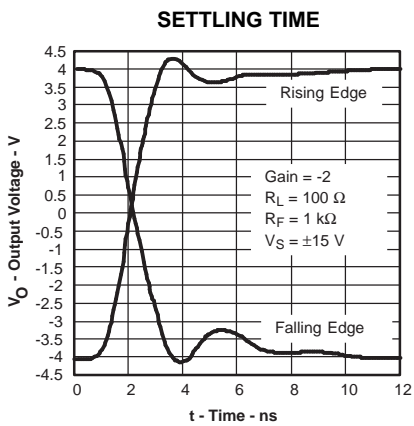

Figure 22.

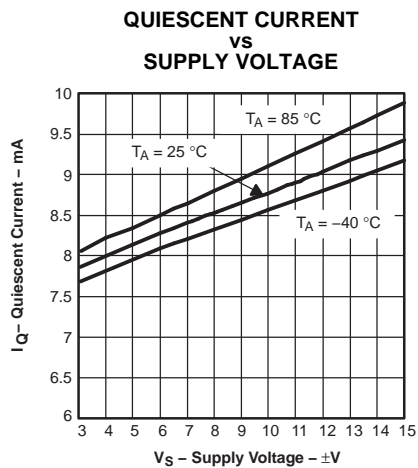

Figure 23.

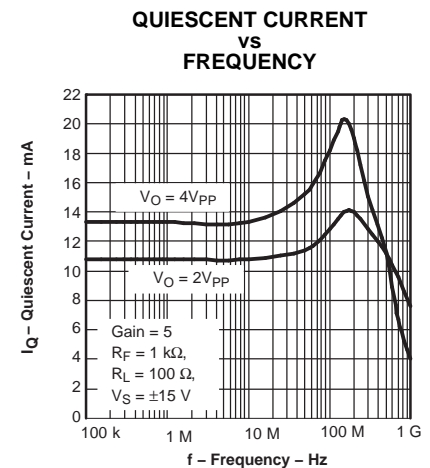

Figure 24.

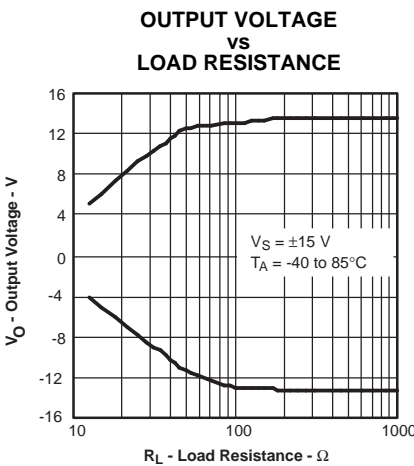

Figure 25.

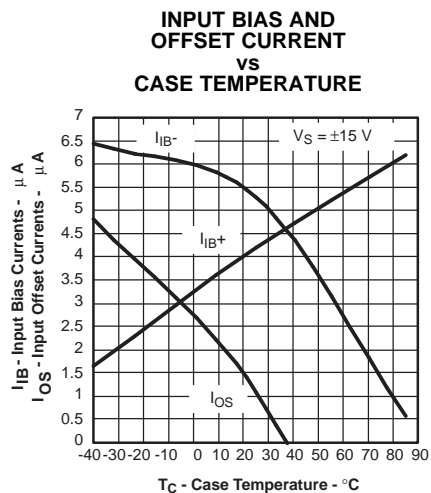

Figure 26.

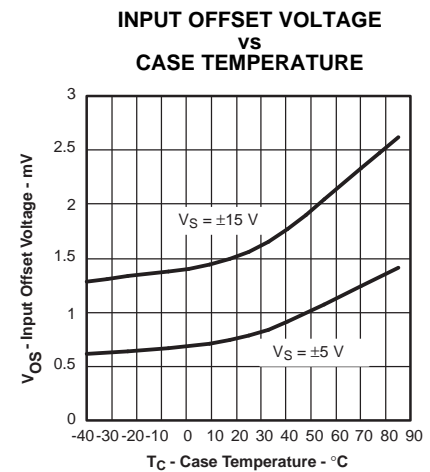

Figure 27.

TYPICAL CHARACTERISTICS (± 15 V) (continued)

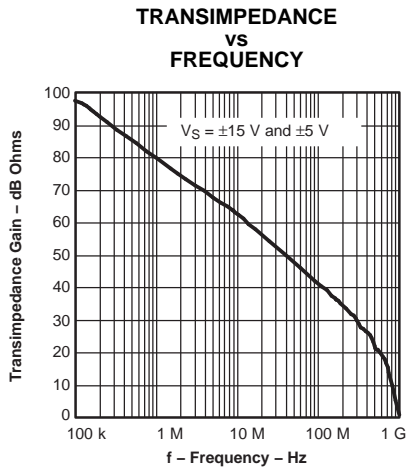

Figure 28.

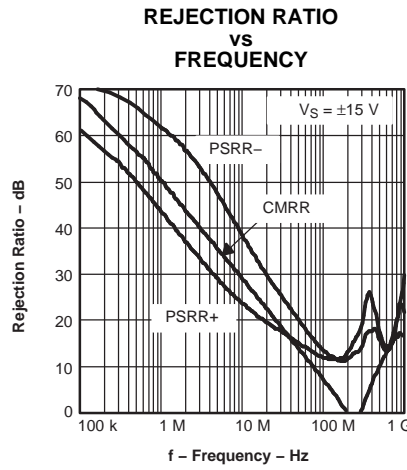

Figure 29.

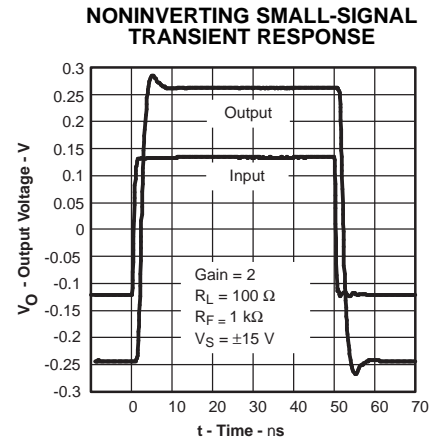

Figure 30.

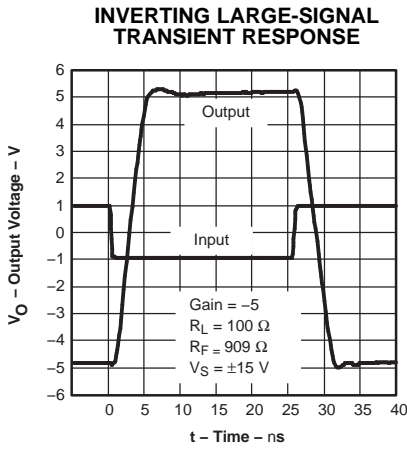

Figure 31.

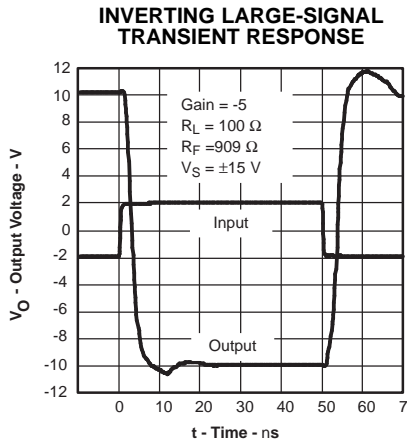

Figure 32.

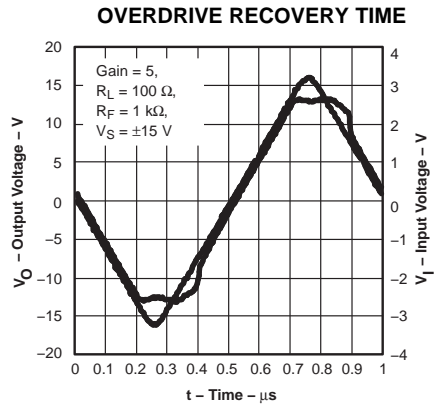

Figure 33.

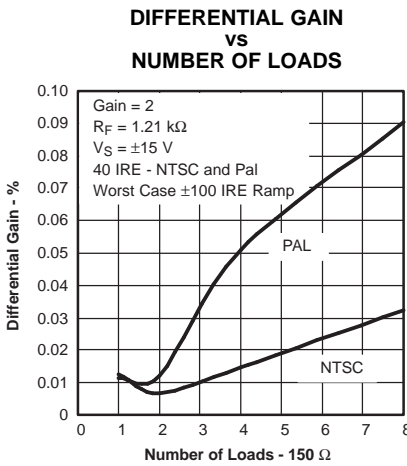

Figure 34.

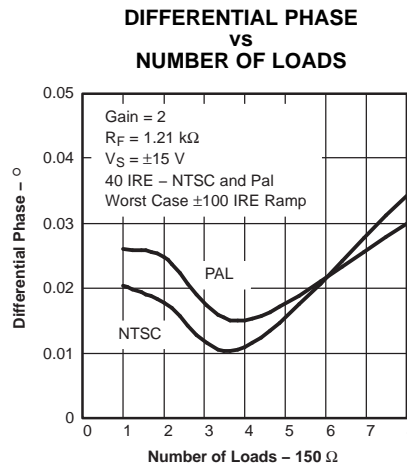

Figure 35.

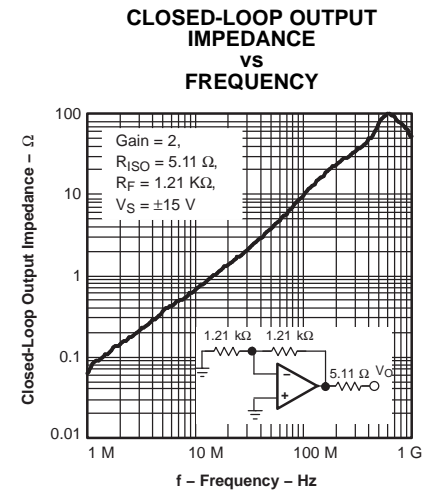

Figure 36.

TYPICAL CHARACTERISTICS (± 15 V) (continued)

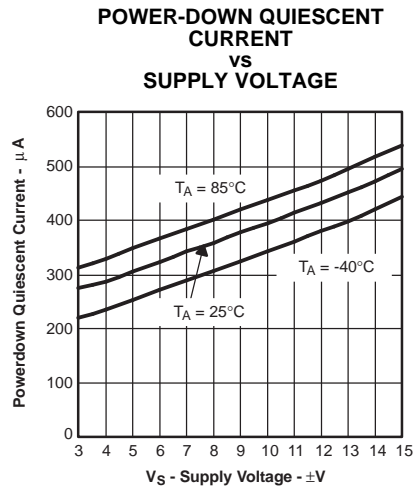

Figure 37.

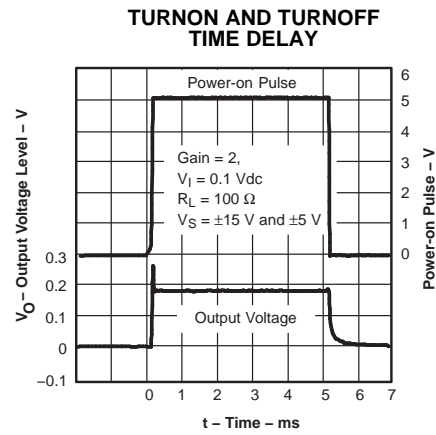

Figure 38.

TYPICAL CHARACTERISTICS (± 5 V)

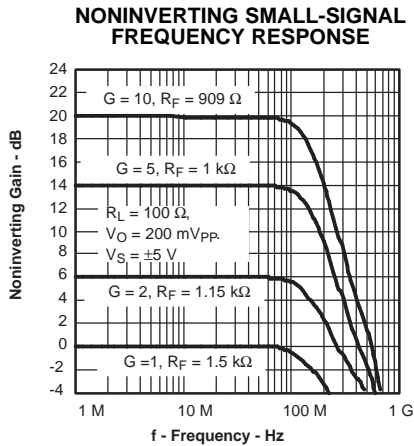

Figure 39.

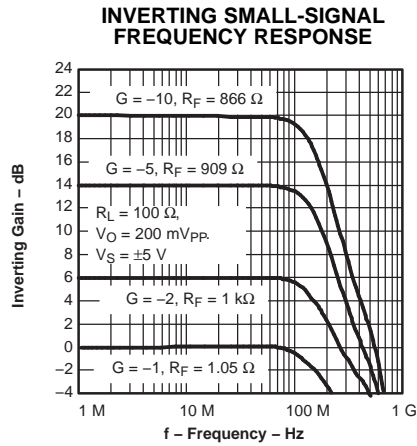

Figure 40.

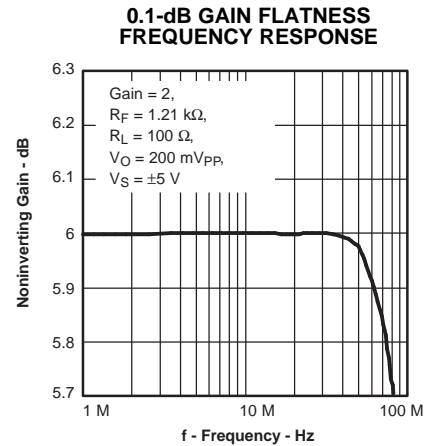

Figure 41.

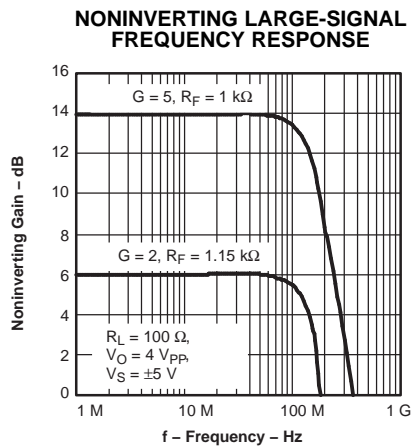

Figure 42.

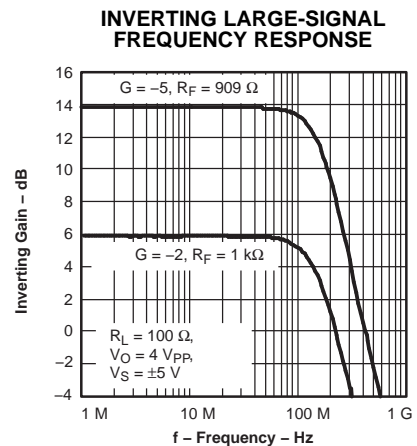

Figure 43.

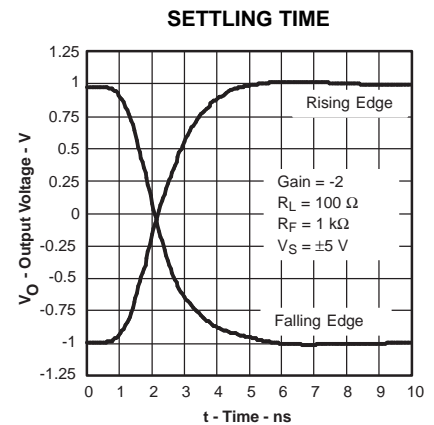

Figure 44.

TYPICAL CHARACTERISTICS (± 5 V) (continued)

2ND HARMONIC DISTORTION
VS
FREQUENCY

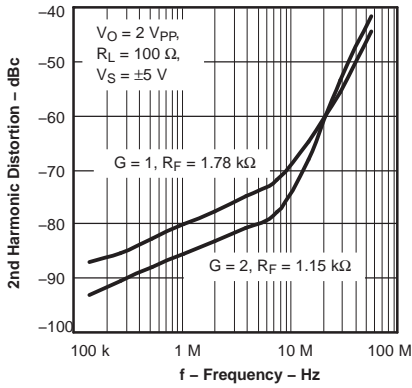

Figure 45.

3RD HARMONIC DISTORTION
VS
FREQUENCY

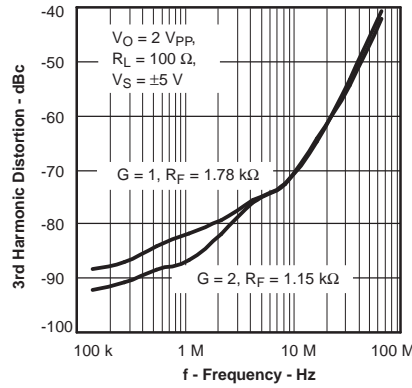

Figure 46.

2ND HARMONIC DISTORTION
VS
FREQUENCY

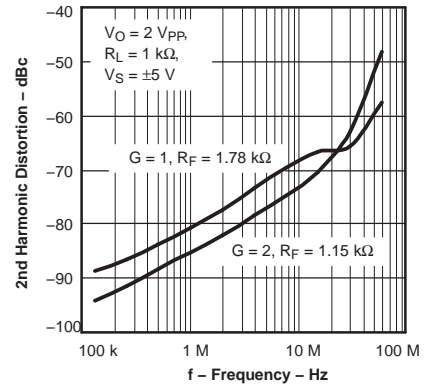

Figure 47.

3RD HARMONIC DISTORTION
VS
FREQUENCY

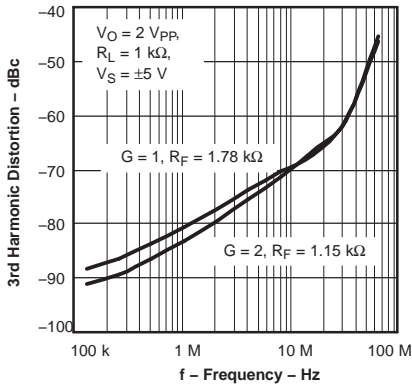

Figure 48.

HARMONIC DISTORTION
VS
OUTPUT VOLTAGE SWING

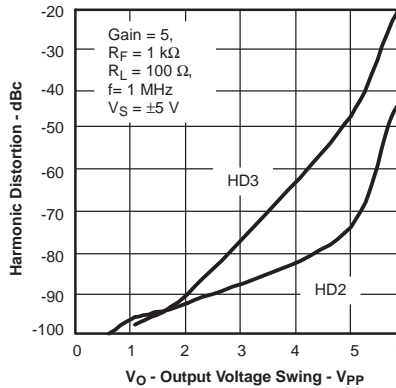

Figure 49.

HARMONIC DISTORTION
VS
OUTPUT VOLTAGE SWING

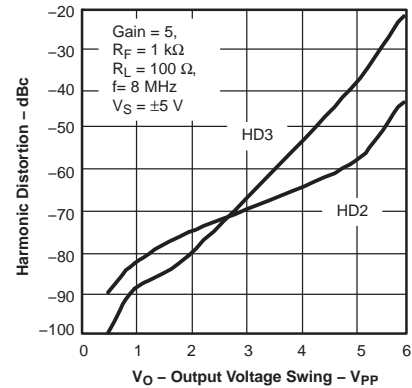

Figure 50.

SLEW RATE
VS
OUTPUT VOLTAGE STEP

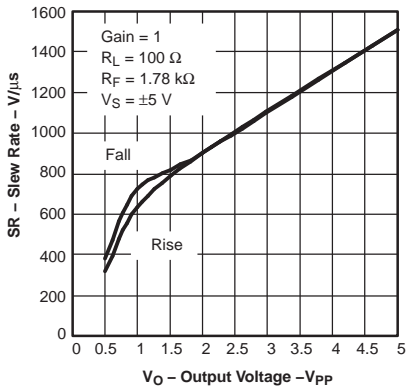

Figure 51.

SLEW RATE
VS
OUTPUT VOLTAGE STEP

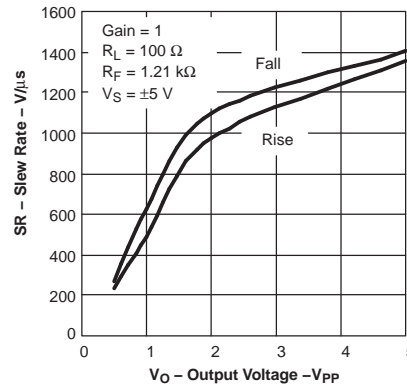

Figure 52.

SLEW RATE
VS
OUTPUT VOLTAGE STEP

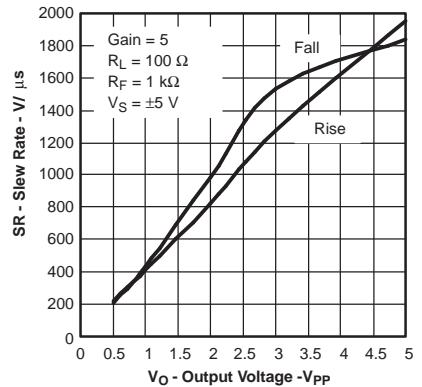

Figure 53.

TYPICAL CHARACTERISTICS (± 5 V) (continued)

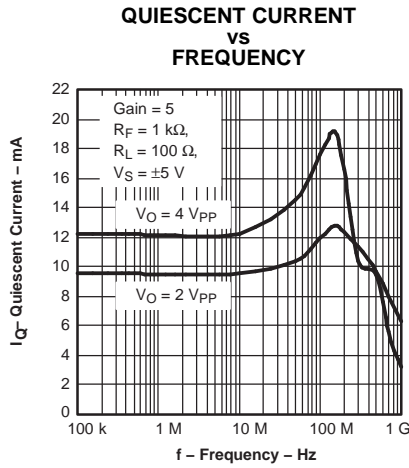

Figure 54.

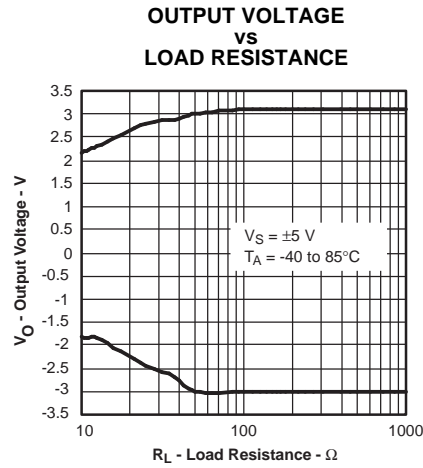

Figure 55.

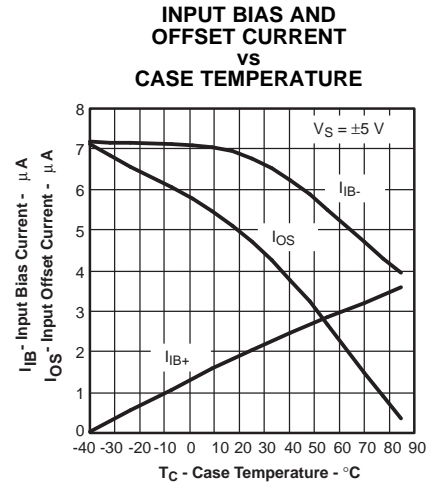

Figure 56.

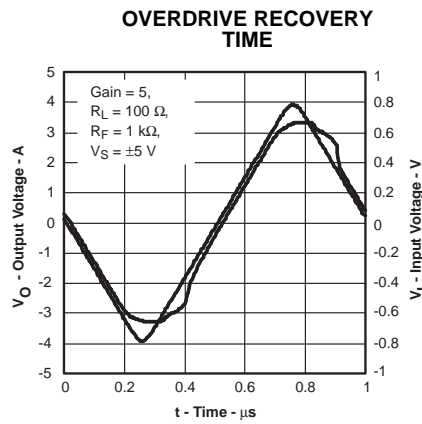

Figure 57.

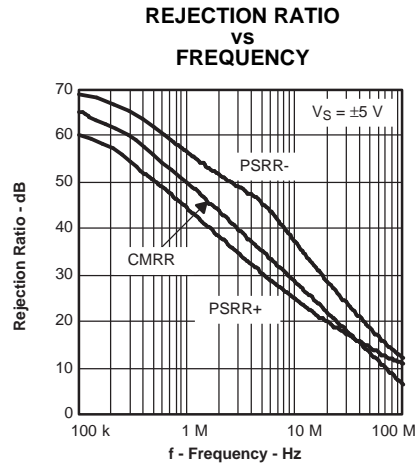

Figure 58.

APPLICATION INFORMATION

WIDEBAND, NONINVERTING OPERATION

The THS3091/5 are unity gain stable 235-MHz current-feedback operational amplifiers, designed to operate from a ± 5 -V to ± 15 -V power supply.

Figure 59 shows the THS3091 in a noninverting gain of 2-V/V configuration typically used to generate the performance curves. Most of the curves were characterized using signal sources with 50- Ω source impedance, and with measurement equipment presenting a 50- Ω load impedance.

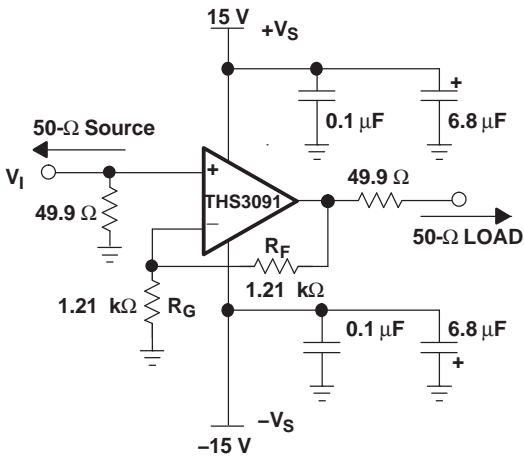

Figure 59. Wideband, Noninverting Gain Configuration

the feedback resistor R_F for maximum performance and stability. Table 1 shows the optimal gain-setting resistors R_F and R_G at different gains to give maximum bandwidth with minimal peaking in the frequency response. Higher bandwidths can be achieved, at the expense of added peaking in the frequency response, by using even lower values for R_F . Conversely, increasing R_F decreases the bandwidth, but stability is improved.

Table 1. Recommended Resistor Values for Optimum Frequency Response

THS3091 and THS3095 R_F and R_G values for minimal peaking with $R_L = 100 \Omega$			
GAIN (V/V)	SUPPLY VOLTAGE (V)	R_G (Ω)	R_F (Ω)
1	± 15	—	1.78 k
	± 5	—	1.78 k
2	± 15	1.21 k	1.21 k
	± 5	1.15 k	1.15 k
5	± 15	249	1 k
	± 5	249	1 k
10	± 15	95.3	866
	± 5	95.3	866
-1	± 15 and ± 5	1.05 k	1.05 k
-2	± 15 and ± 5	499	1 k
-5	± 15 and ± 5	182	909
-10	± 15 and ± 5	86.6	866

Current-feedback amplifiers are highly dependent on

WIDEBAND, INVERTING OPERATION

Figure 60 shows the THS3091 in a typical inverting gain configuration where the input and output impedances and signal gain from Figure 59 are retained in an inverting circuit configuration.

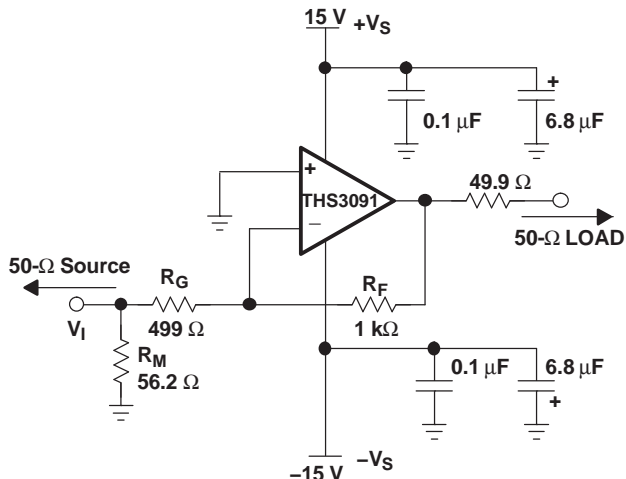

Figure 60. Wideband, Inverting Gain Configuration

SINGLE-SUPPLY OPERATION

The THS3091/5 have the capability to operate from a single-supply voltage ranging from 10 V to 30 V. When operating from a single power supply, biasing the input and output at mid-supply allows for the maximum output voltage swing. The circuits shown in Figure 61 show inverting and noninverting amplifiers configured for single-supply operations.

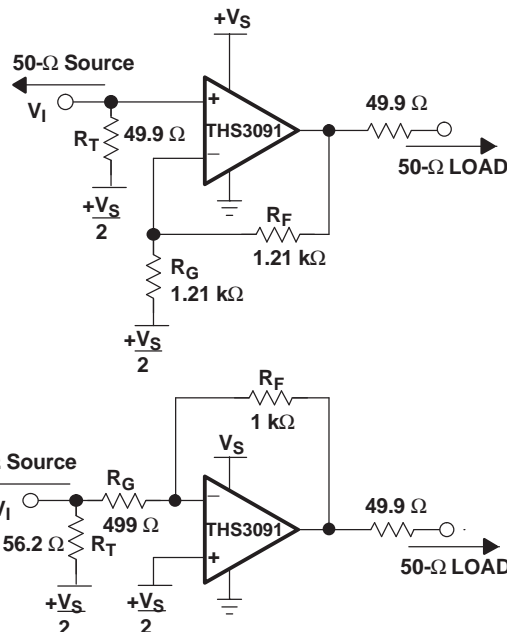

Figure 61. DC-Coupled, Single-Supply Operation

Video Distribution

The wide bandwidth, high slew rate, and high output drive current of the THS3091/5 matches the demands for video distribution for delivering video signals down multiple cables. To ensure high signal quality with minimal degradation of performance, a 0.1-dB gain flatness should be at least 7x the passband frequency to minimize group delay variations from the amplifier. A high slew rate minimizes distortion of the video signal, and supports component video and RGB video signals that require fast transition times and fast settling times for high signal quality.

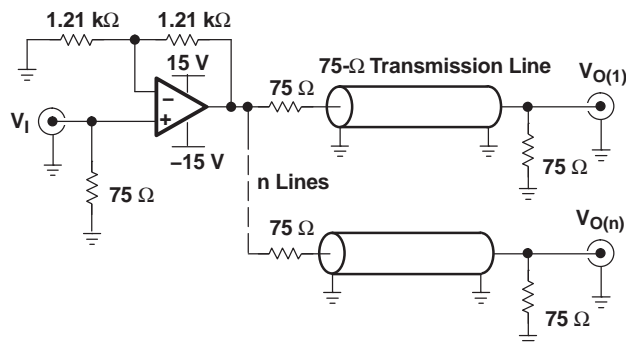

Figure 62. Video Distribution Amplifier Application

Driving Capacitive Loads

Applications such as FET line drivers can be highly capacitive and cause stability problems for high-speed amplifiers.

Figure 63 through Figure 68 show recommended methods for driving capacitive loads. The basic idea is to use a resistor or ferrite chip to isolate the phase shift at high frequency caused by the capacitive load from the amplifier's feedback path. See Figure 63 for recommended resistor values versus capacitive load.

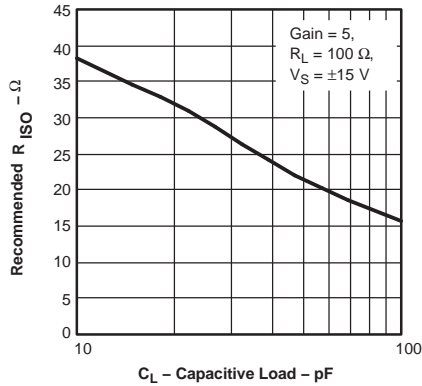

Figure 63. Recommended R_{ISO} vs Capacitive Load

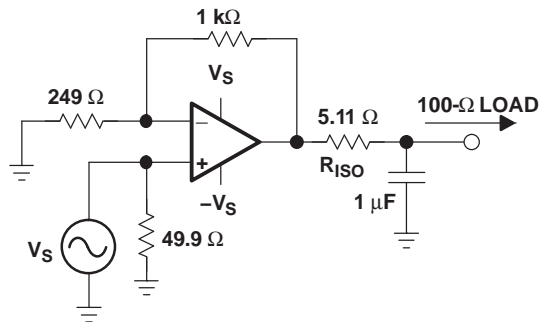

Figure 64.

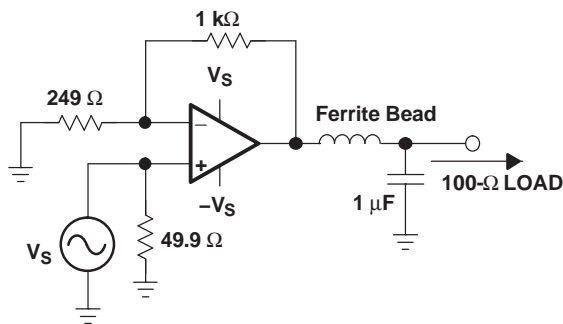

Figure 65.

Placing a small series resistor, R_{ISO}, between the amplifier's output and the capacitive load, as shown in Figure 64, is an easy way of isolating the load capacitance.

Using a ferrite chip in place of R_{ISO}, as shown in Figure 65, is another approach of isolating the output of the amplifier. The ferrite's impedance characteristic versus frequency is useful to maintain the low-frequency load independence of the amplifier while isolating the phase shift caused by the capacitance at high frequency. Use a ferrite with similar impedance to R_{ISO}, 20 ohms - 50 ohms, at 100 MHz and low impedance at dc.

Figure 66 shows another method used to maintain the low-frequency load independence of the amplifier while isolating the phase shift caused by the capacitance at high frequency. At low frequency, feedback is mainly from the load side of R_{ISO}. At high frequency, the feedback is mainly via the 27-pF capacitor. The resistor R_{IN} in series with the negative input is used to stabilize the amplifier and should be equal to the recommended value of R_F at unity gain. Replacing R_{IN} with a ferrite of similar impedance at about 100 MHz as shown in Figure 67 gives similar results with reduced dc offset and low-frequency noise. (See the *ADDITIONAL REFERENCE MATERIAL* section for expanding the usability of current-feedback amplifiers.)

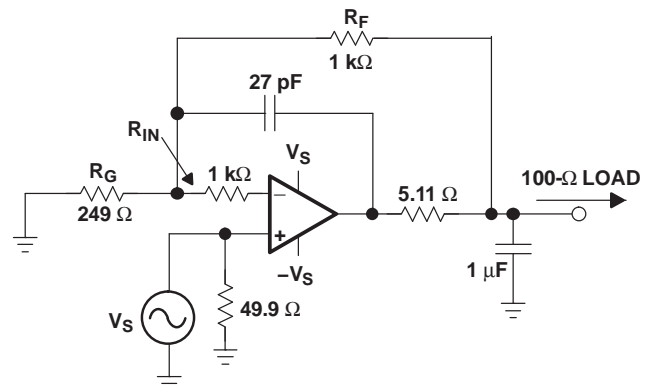

Figure 66.

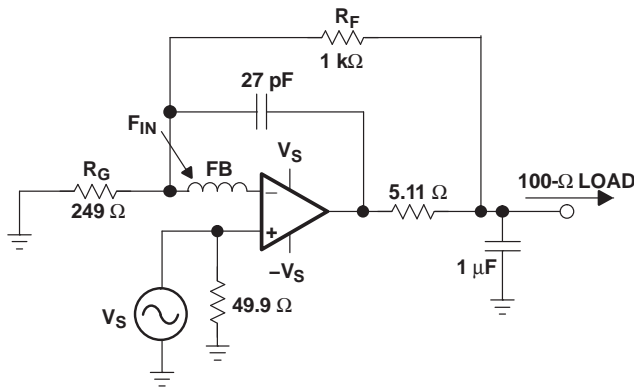

Figure 67.

Figure 68 is shown using two amplifiers in parallel to double the output drive current to larger capacitive loads. This technique is used when more output current is needed to charge and discharge the load faster like when driving large FET transistors.

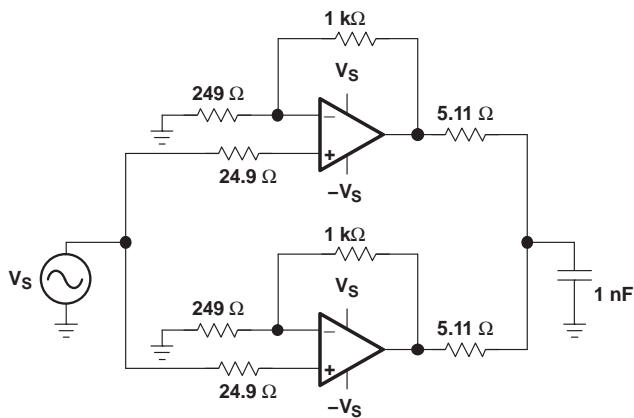

Figure 68.

Figure 69 shows a push-pull FET driver circuit typical of ultrasound applications with isolation resistors to isolate the gate capacitance from the amplifier.

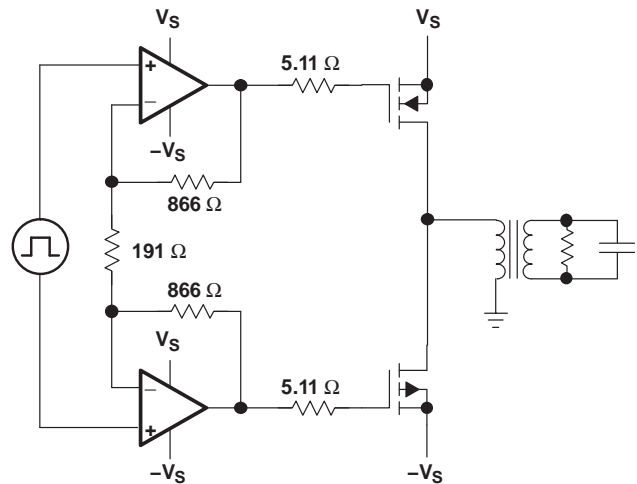

Figure 69. PowerFET Drive Circuit

SAVING POWER WITH POWER-DOWN FUNCTIONALITY AND SETTING THRESHOLD LEVELS WITH THE REFERENCE PIN

The THS3095 features a power-down pin (\overline{PD}) which lowers the quiescent current from 9.5 mA down to 500 μ A, ideal for reducing system power.

The power-down pin of the amplifier defaults to the positive supply voltage in the absence of an applied voltage, putting the amplifier in the power-on mode of operation. To turn off the amplifier in an effort to conserve power, the power-down pin can be driven towards the negative rail. The threshold voltages for power-on and power-down are relative to the supply rails and are given in the specification tables. Above the *Enable Threshold Voltage*, the device is on. Below the *Disable Threshold Voltage*, the device is off. Behavior in between these threshold voltages is not specified.

Note that this power-down functionality is just that; the amplifier consumes less power in power-down mode. The power-down mode is not intended to provide a high-impedance output. In other words, the power-down functionality is not intended to allow use as a 3-state bus driver. When in power-down mode, the impedance looking back into the output of the amplifier is dominated by the feedback and gain-setting resistors, but the output impedance of the device itself varies depending on the voltage applied to the outputs.

Figure 70 shows the total system output impedance which includes the amplifier output impedance in parallel with the feedback plus gain resistors, which cumulate to 2380 Ω . Figure 59 shows this circuit configuration for reference.

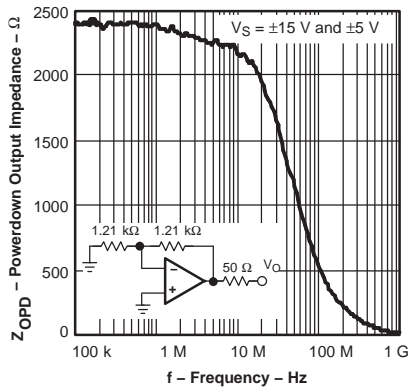

Figure 70. Power-down Output Impedance vs Frequency

As with most current feedback amplifiers, the internal architecture places some limitations on the system when in power-down mode. Most notably is the fact that the amplifier actually turns ON if there is a ± 0.7 V or greater difference between the two input nodes (V_+ and V_-) of the amplifier. If this difference exceeds ± 0.7 V, the output of the amplifier creates an output voltage equal to approximately $[(V_+ - V_-) - 0.7 \text{ V}] \times \text{Gain}$. This also implies that if a voltage is applied to the output while in power-down mode, the V_- node voltage is equal to $V_{O(\text{applied})} \times R_G / (R_F + R_G)$. For low gain configurations and a large applied voltage at the output, the amplifier may actually turn ON due to the aforementioned behavior.

The time delays associated with turning the device on and off are specified as the time it takes for the amplifier to reach either 10% or 90% of the final output voltage. The time delays are in the order of microseconds because the amplifier moves in and out of the linear mode of operation in these transitions.

POWER-DOWN REFERENCE PIN OPERATION

In addition to the power-down pin, the THS3095 features a reference pin (REF) which allows the user to control the enable or disable power-down voltage levels applied to the $\overline{\text{PD}}$ pin. In most split-supply applications, the reference pin is connected to ground. In either case, the user needs to be aware of voltage-level thresholds that apply to the power-down pin. The tables below show examples and illustrate the relationship between the reference voltage and the power-down thresholds. In the table, the threshold levels are derived by the following equations:

$$\overline{\text{PD}} \leq \text{REF} + 0.8 \text{ V for disable}$$

$$\overline{\text{PD}} \geq \text{REF} + 2.0 \text{ V for enable}$$

where the usable range at the REF pin is

$$V_{S-} \leq V_{\text{REF}} \leq (V_{S+} - 4 \text{ V}).$$

The recommended mode of operation is to tie the REF pin to midrail, thus setting the enable/disable thresholds to $V_{\text{midrail}} + 2.0 \text{ V}$ and $V_{\text{midrail}} + 0.8 \text{ V}$ respectively.

POWER-DOWN THRESHOLD VOLTAGE LEVELS			
SUPPLY VOLTAGE(V)	REFERENCE PIN VOLTAGE (V)	ENABLE LEVEL (V)	DISABLE LEVEL (V)
$\pm 15, \pm 5$	0.0	2.0	0.8
± 15	2.0	4.0	2.8
± 15	-2.0	0.0	-1.2
± 5	1.0	3.0	1.8
± 5	-1.0	1.0	-0.2
+30	15	17	15.8
+10	5.0	7.0	5.8

Note that if the REF pin is left unterminated, it will float to the positive rail and will fall outside of the recommended operating range given above ($V_{S-} \leq V_{\text{REF}} \leq V_{S+} - 4 \text{ V}$). As a result, it will no longer serve as a reliable reference for the $\overline{\text{PD}}$ pin and the enable/disable thresholds given above will no longer apply. If the $\overline{\text{PD}}$ pin is also left unterminated, it will also float to the positive rail and the device will be enabled. If balanced, split supplies are used ($\pm V_S$) and the REF and $\overline{\text{PD}}$ pins are grounded, the device will be disabled.

PRINTED-CIRCUIT BOARD LAYOUT TECHNIQUES FOR OPTIMAL PERFORMANCE

Achieving optimum performance with a high-frequency amplifier, like the THS3091/5, requires careful attention to board layout parasitic and external component types.

Recommendations that optimize performance include:

- Minimize parasitic capacitance to any ac ground for all of the signal I/O pins. Parasitic capacitance on the output and input pins can cause instability. To reduce unwanted capacitance, a window around the signal I/O pins should be opened in all of the ground and power planes around those pins. Otherwise, ground and power planes should be unbroken elsewhere on the board.
- Minimize the distance [< 0.25 inch (6,35 mm)] from the power supply pins to high-frequency 0.1- μF and 100-pF decoupling capacitors. At the device pins, the ground and power plane layout should not be in close proximity to the signal I/O pins. Avoid narrow power and ground traces to minimize inductance between the pins and the decoupling capacitors. The power supply connections should always be decoupled with these capacitors. Larger (6.8 μF or more)

tantalum decoupling capacitors, effective at lower frequency, should also be used on the main supply pins. These may be placed somewhat farther from the device and may be shared among several devices in the same area of the PC board.

- Careful selection and placement of external components preserve the high-frequency performance of the THS3091/5. Resistors should be a low reactance type. Surface-mount resistors work best and allow a tighter overall layout. Again, keep their leads and PC board trace length as short as possible. Never use wirebound type resistors in a high-frequency application. Because the output pin and inverting input pins are the most sensitive to parasitic capacitance, always position the feedback and series output resistors, if any, as close as possible to the inverting input pins and output pins. Other network components, such as input termination resistors, should be placed close to the gain-setting resistors. Even with a low parasitic capacitance shunting the external resistors, excessively high resistor values can create significant time constants that can degrade performance. Good axial metal-film or surface-mount resistors have approximately 0.2 pF in shunt with the resistor. For resistor values > 2 k Ω , this parasitic capacitance can add a pole and/or a zero that can effect circuit operation. Keep resistor values as low as possible, consistent with load-driving considerations.
- Connections to other wideband devices on the board may be made with short direct traces or through onboard transmission lines. For short connections, consider the trace and the input to the next device as a lumped capacitive load. Relatively wide traces [0.05 inch (1,3 mm) to 0.1 inch (2,54 mm)] should be used, preferably with ground and power planes opened up around them. Estimate the total capacitive load and determine if isolation resistors on the outputs are necessary. Low parasitic capacitive loads (< 4

pF) may not need an R_S because the THS3091/5 are nominally compensated to operate with a 2-pF parasitic load. Higher parasitic capacitive loads without an R_S are allowed as the signal gain increases (increasing the unloaded phase margin). If a long trace is required, and the 6-dB signal loss intrinsic to a doubly terminated transmission line is acceptable, implement a matched impedance transmission line using microstrip or stripline techniques (consult an ECL design handbook for microstrip and stripline layout techniques). A 50- Ω environment is not necessary onboard, and in fact, a higher impedance environment improves distortion as shown in the distortion versus load plots. With a characteristic board trace impedance based on board material and trace dimensions, a matching series resistor into the trace from the output of the THS3091/5 is used as well as a terminating shunt resistor at the input of the destination device. Remember also that the terminating impedance is the parallel combination of the shunt resistor and the input impedance of the destination device; this total effective impedance should be set to match the trace impedance. If the 6-dB attenuation of a doubly terminated transmission line is unacceptable, a long trace can be series-terminated at the source end only. Treat the trace as a capacitive load in this case. This does not preserve signal integrity as well as a doubly terminated line. If the input impedance of the destination device is low, there is some signal attenuation due to the voltage divider formed by the series output into the terminating impedance.

- Socketing a high-speed part like the THS3091/5 is not recommended. The additional lead length and pin-to-pin capacitance introduced by the socket can create an extremely troublesome parasitic network which can make it almost impossible to achieve a smooth, stable frequency response. Best results are obtained by soldering the THS3091/5 parts directly onto the board.

PowerPAD™ DESIGN CONSIDERATIONS

The THS3091/5 are available in a thermally-enhanced PowerPAD family of packages. These packages are constructed using a downset leadframe on which the die is mounted [see Figure 71(a) and Figure 71(b)]. This arrangement results in the lead frame being exposed as a thermal pad on the underside of the package [see Figure 71(c)]. Because this thermal pad has direct thermal contact with the die, excellent thermal performance can be achieved by providing a good thermal path away from the thermal pad. Note that devices such as the THS3091/5 have no electrical connection between the PowerPAD and the die.

The PowerPAD package allows for both assembly and thermal management in one manufacturing operation. During the surface-mount solder operation (when the leads are being soldered), the thermal pad can also be soldered to a copper area underneath the package. Through the use of thermal paths within this copper area, heat can be conducted away from the package into either a ground plane or other heat-dissipating device.

The PowerPAD package represents a breakthrough in combining the small area and ease of assembly of surface mount with the, heretofore, awkward mechanical methods of heatsinking.

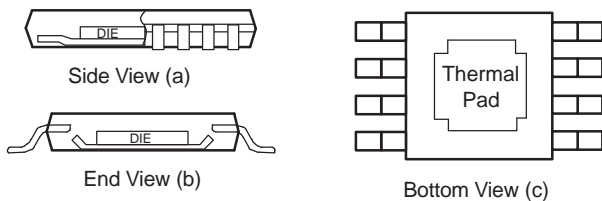

Figure 71. Views of Thermal Enhanced Package

Although there are many ways to properly heatsink the PowerPAD package, the following steps illustrate the recommended approach.

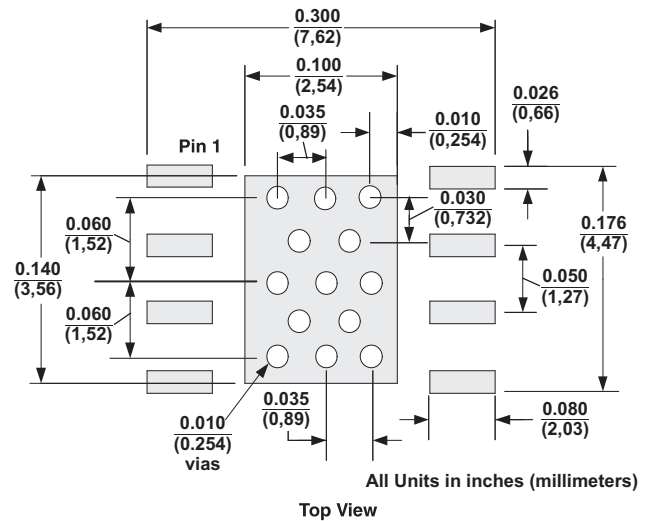

Figure 72. DDA PowerPAD PCB Etch and Via Pattern

PowerPAD™ LAYOUT CONSIDERATIONS

1. PCB with a top-side etch pattern is shown in Figure 72. There should be etch for the leads as well as etch for the thermal pad.
2. Place 13 holes in the area of the thermal pad. These holes should be 0.01 inch (0,254 mm) in diameter. Keep them small so that solder wicking through the holes is not a problem during reflow.
3. Additional vias may be placed anywhere along the thermal plane outside of the thermal pad area. This helps dissipate the heat generated by the THS3091/5 IC. These additional vias may be larger than the 0.01-inch (0,254 mm) diameter vias directly under the thermal pad. They can be larger because they are not in the thermal pad area to be soldered so that wicking is not a problem.
4. Connect all holes to the internal ground plane. Note that the PowerPAD is electrically isolated from the silicon and all leads. Connecting the PowerPAD to any potential voltage such as V_{S-} is acceptable as there is no electrical connection to the silicon.
5. When connecting these holes to the ground plane, do not use the typical web or spoke via connection methodology. Web connections have a high thermal resistance connection that is useful for slowing the heat transfer during soldering operations. This makes the soldering of vias that have plane connections easier. In this application, however, low thermal resistance is desired for the most efficient heat transfer. Therefore, the holes under the THS3091/5 PowerPAD package

should make their connection to the internal ground plane with a complete connection around the entire circumference of the plated-through hole.

6. The top-side solder mask should leave the terminals of the package and the thermal pad area with its 13 holes exposed. The bottom-side solder mask should cover the 13 holes of the thermal pad area. This prevents solder from being pulled away from the thermal pad area during the reflow process.
7. Apply solder paste to the exposed thermal pad area and all of the IC terminals.
8. With these preparatory steps in place, the IC is simply placed in position and run through the solder reflow operation as any standard surface-mount component. This results in a part that is properly installed.

POWER DISSIPATION AND THERMAL CONSIDERATIONS

The THS3091/5 incorporates automatic thermal shutoff protection. This protection circuitry shuts down the amplifier if the junction temperature exceeds approximately 160°C. When the junction temperature reduces to approximately 140°C, the amplifier turns on again. But, for maximum performance and reliability, the designer must ensure that the design does not exceed a junction temperature of 125°C. Between 125°C and 150°C, damage does not occur, but the performance of the amplifier begins to degrade and long-term reliability suffers. The thermal characteristics of the device are dictated by the package and the PC board. Maximum power dissipation for a given package can be calculated using the following formula.

$$P_{Dmax} = \frac{T_{max} - T_A}{\theta_{JA}}$$

where:

P_{Dmax} is the maximum power dissipation in the amplifier (W).

T_{max} is the absolute maximum junction temperature (°C).

T_A is the ambient temperature (°C).

$$\theta_{JA} = \theta_{JC} + \theta_{CA}$$

θ_{JC} is the thermal coefficient from the silicon junctions to the case (°C/W).

θ_{CA} is the thermal coefficient from the case to ambient air (°C/W).

For systems where heat dissipation is more critical, the THS3091 and THS3095 are offered in an 8-pin SOIC (DDA) with PowerPAD package. The thermal coefficient for the PowerPAD packages are substantially improved over the traditional SOIC. Maximum power dissipation levels are depicted in the graph for the available packages. The data for

the PowerPAD packages assume a board layout that follows the PowerPAD layout guidelines referenced above and detailed in the PowerPAD application note (SLMA002). The following graph also illustrates the effect of not soldering the PowerPAD to a PCB. The thermal impedance increases substantially which may cause serious heat and performance issues. Be sure to always solder the PowerPAD to the PCB for optimum performance.

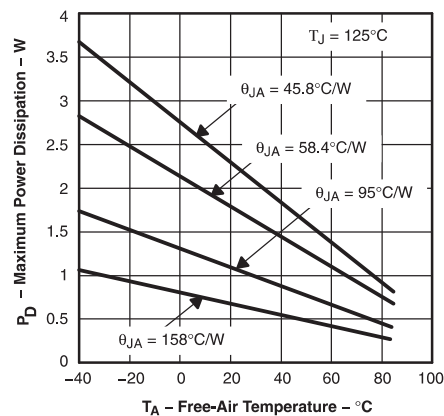

Results are With No Air Flow and PCB Size = 3 inches x 3 inches (76,2 mm x 76,2 mm)
 $\theta_{JA} = 45.8^\circ\text{C/W}$ for 8-Pin SOIC w/PowerPAD (DDA)
 $\theta_{JA} = 58.4^\circ\text{C/W}$ for 8-Pin MSOP w/PowerPAD (DGN)
 $\theta_{JA} = 95^\circ\text{C/W}$ for 8-Pin SOIC High-K Test PCB (D)
 $\theta_{JA} = 158^\circ\text{C/W}$ for 8-Pin MSOP w/PowerPAD w/o Solder

Figure 73. Maximum Power Distribution vs Ambient Temperature

When determining whether or not the device satisfies the maximum power dissipation requirement, it is important to consider not only quiescent power dissipation, but also dynamic power dissipation. Often times, this is difficult to quantify because the signal pattern is inconsistent, but an estimate of the RMS power dissipation can provide visibility into a possible problem.

DESIGN TOOLS

Evaluation Fixtures, Spice Models, and Application Support

Texas Instruments is committed to providing its customers with the highest quality of applications support. To support this goal, an evaluation board has been developed for the THS3091/5 operational amplifier. The board is easy to use, allowing for straightforward evaluation of the device. The evaluation board can be ordered through the Texas Instruments Web site, www.ti.com, or through your local Texas Instruments sales representative.

Computer simulation of circuit performance using SPICE is often useful when analyzing the

performance of analog circuits and systems. This is particularly true for video and RF-amplifier circuits where parasitic capacitance and inductance can have a major effect on circuit performance. A SPICE model for the THS3091/5 is available through the Texas Instruments Web site (www.ti.com). The Product Information Center (PIC) is also available for design assistance and detailed product information. These models do a good job of predicting small-signal ac and transient performance under a wide variety of operating conditions. They are not intended to model the distortion characteristics of the amplifier, nor do they attempt to distinguish between the package types in their small-signal ac performance. Detailed information about what is and is not modeled is contained in the model file itself.

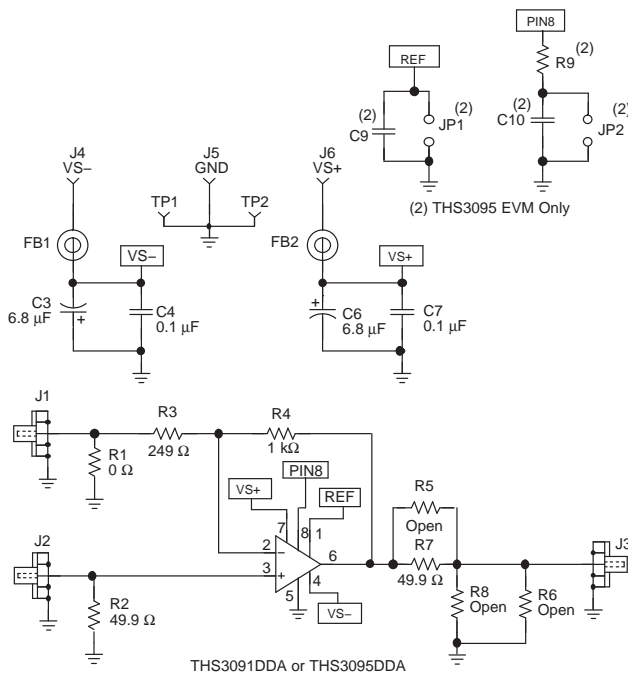

Figure 74. THS3091 EVM Circuit Configuration

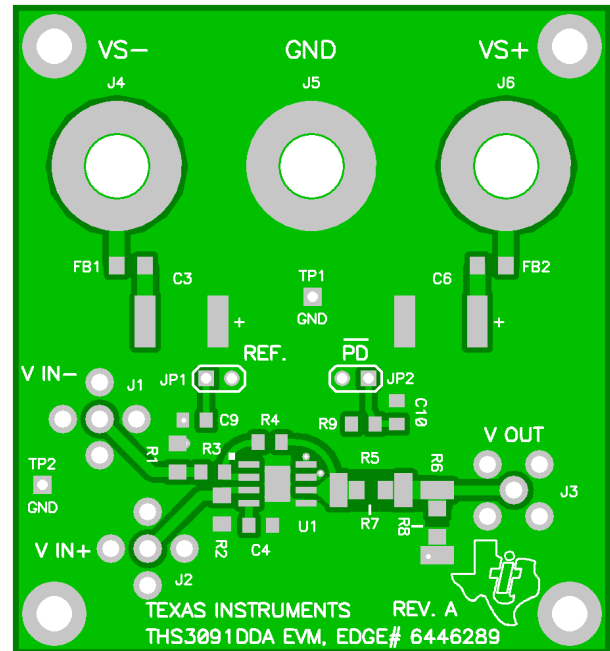

Figure 75. THS3091 EVM Board Layout (Top Layer)

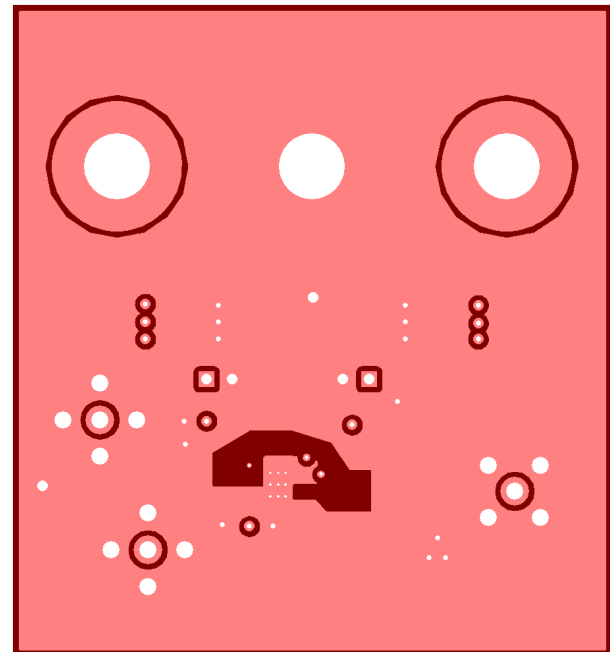

Figure 76. THS3091 EVM Board Layout (Second and Third Layers)

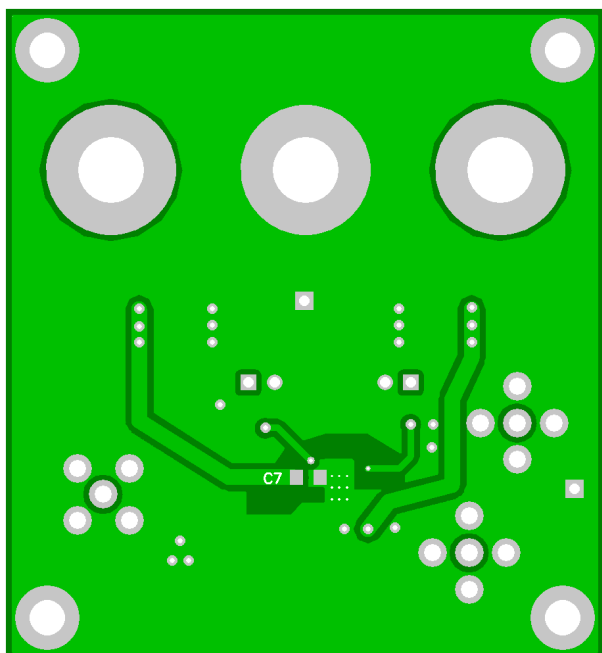

Figure 77. THS3091 EVM Board Layout
(Bottom Layer)

Table 2. Bill of Materials

THS3091DDA and THS3095DDA EVM ⁽¹⁾						
ITEM	DESCRIPTION	SMD SIZE	REFERENCE DESIGNATOR	PCB QTY	MANUFACTURER'S PART NUMBER	DISTRIBUTOR'S PART NUMBER
1	Bead, Ferrite, 3 A, 80 Ω	1206	FB1, FB2	2	(Steward) HI1206N800R-00	(Digi-Key) 240-1010-1-ND
2	Cap, 6.8 μF, Tanatalum, 50 V, 10%	D	C3, C6	2	(AVX) TAJD685K050R	(Garrett) TAJD685K050R
3	Cap, 0.1 μF, ceramic, X7R, 50 V	0805	C9, C10	2 ⁽²⁾	(AVX) 08055C104KAT2A	(Garrett) 08055C104KAT2A
4	Cap, 0.1 μF, ceramic, X7R, 50 V	0805	C4, C7	2	(AVX) 08055C104KAT2A	(Garrett) 08055C104KAT2A
5	Resistor, 0 Ω, 1/8 W, 1%	0805	R9	1 ⁽²⁾	(KOA) RK73Z2ALTD	(Garrett) RK73Z2ALTD
6	Resistor, 249 Ω, 1/8 W, 1%	0805	R3	1	(KOA) RK73H2ALTD2490F	(Garrett) RK73H2ALTD2490F
7	Resistor, 1 kΩ, 1/8 W, 1%	0805	R4	1	(KOA) RK73H2ALTD1001F	(Garrett) RK73H2ALTD1001F
8	Open	1206	R8	1		
9	Resistor, 0 Ω, 1/4 W, 1%	1206	R1	1	(KOA) RK73Z2BLTD	(Garrett) RK73Z2BLTD
10	Resistor, 49.9 Ω, 1/4 W, 1%	1206	R2, R7	2	(KOA) RK73Z2BLTD49R9F	(Garrett) RK73Z2BLTD49R9F
11	Open	2512	R5, R6	2		
12	Header, 0.1-inch (2,54 mm) centers, 0.025-inch (6,35 mm) square pins		JP1, JP2	2 ⁽²⁾	(Sullins) PZC36SAAN	(Digi-Key) S1011-36-ND
13	Connector, SMA PCB Jack		J1, J2, J3	3	(Amphenol) 901-144-8RFX	(Newark) 01F2208
14	Jack, banana receptacle, 0.25-inch (6,35 mm) dia. hole		J4, J5, J6	3	(SPC) 813	(Newark) 39N867
15	Test point, black		TP1, TP2	2	(Keystone) 5001	(Digi-Key) 5001K-ND
16	Standoff, 4-40 hex, 0.625-inch (15,9 mm) length			4	(Keystone) 1808	(Newark) 89F1934
17	Screw, Phillips, 4-40, 0.25-inch (6,35 mm)			4	SHR-0440-016-SN	
18	IC, THS3091(3) IC, THS3095(2)		U1	1	(TI) THS3091DDA ⁽³⁾ (TI) THS3095DDA ⁽²⁾	
19	Board, printed-circuit			1	(TI) EDGE # 6446289 Rev. A ⁽³⁾ (TI) EDGE # 6446290 Rev. A ⁽²⁾	

(1) All items are designated for both the THS3091DDA and THS3095 EVMs unless otherwise noted.

(2) THS3095 EVM only.

(3) THS3091 EVM only.

ADDITIONAL REFERENCE MATERIAL

- PowerPAD™ Made Easy, application brief ([SLMA004](#))
- PowerPAD™ Thermally Enhanced Package, technical brief ([SLMA002](#))
- Voltage Feedback vs Current Feedback Amplifiers, ([SLVA051](#))
- Current Feedback Analysis and Compensation ([SLOA021](#))
- Current Feedback Amplifiers: Review, Stability, and Application ([SBOA081](#))
- Effect of Parasitic Capacitance in Op Amp Circuits ([SLOA013](#))
- Expanding the Usability of Current-Feedback Amplifiers, 3Q 2003 Analog Applications Journal (www.ti.com/sc/analogapps).

PACKAGING INFORMATION

Orderable Device	Status ⁽¹⁾	Package Type	Package Drawing	Pins	Package Qty	Eco Plan ⁽²⁾	Lead/Ball Finish	MSL Peak Temp ⁽³⁾
THS3091D	ACTIVE	SOIC	D	8	75	Green (RoHS & no Sb/Br)	CU NIPDAU	Level-1-260C-UNLIM
THS3091DDA	ACTIVE	SO Power PAD	DDA	8	75	Green (RoHS & no Sb/Br)	Call TI	Level-1-260C-UNLIM
THS3091DDAG3	ACTIVE	SO Power PAD	DDA	8	75	Green (RoHS & no Sb/Br)	Call TI	Level-1-260C-UNLIM
THS3091DDAR	ACTIVE	SO Power PAD	DDA	8	2500	Green (RoHS & no Sb/Br)	Call TI	Level-1-260C-UNLIM
THS3091DDARG3	ACTIVE	SO Power PAD	DDA	8	2500	Green (RoHS & no Sb/Br)	Call TI	Level-1-260C-UNLIM
THS3091DG4	ACTIVE	SOIC	D	8	75	Green (RoHS & no Sb/Br)	CU NIPDAU	Level-1-260C-UNLIM
THS3091DR	ACTIVE	SOIC	D	8	2500	Green (RoHS & no Sb/Br)	CU NIPDAU	Level-1-260C-UNLIM
THS3091DRG4	ACTIVE	SOIC	D	8	2500	Green (RoHS & no Sb/Br)	CU NIPDAU	Level-1-260C-UNLIM
THS3095D	ACTIVE	SOIC	D	8	75	Green (RoHS & no Sb/Br)	CU NIPDAU	Level-1-260C-UNLIM
THS3095DDA	ACTIVE	SO Power PAD	DDA	8	75	Green (RoHS & no Sb/Br)	Call TI	Level-1-260C-UNLIM
THS3095DDAG4	ACTIVE	SO Power PAD	DDA	8	75	Green (RoHS & no Sb/Br)	Call TI	Level-1-260C-UNLIM
THS3095DDAR	ACTIVE	SO Power PAD	DDA	8	2500	Green (RoHS & no Sb/Br)	Call TI	Level-1-260C-UNLIM
THS3095DDARG3	ACTIVE	SO Power PAD	DDA	8	2500	Green (RoHS & no Sb/Br)	Call TI	Level-1-260C-UNLIM
THS3095DG4	ACTIVE	SOIC	D	8	75	Green (RoHS & no Sb/Br)	CU NIPDAU	Level-1-260C-UNLIM
THS3095DR	ACTIVE	SOIC	D	8	2500	Green (RoHS & no Sb/Br)	CU NIPDAU	Level-1-260C-UNLIM
THS3095DRG4	ACTIVE	SOIC	D	8	2500	Green (RoHS & no Sb/Br)	CU NIPDAU	Level-1-260C-UNLIM

⁽¹⁾ The marketing status values are defined as follows:

ACTIVE: Product device recommended for new designs.

LIFEBUY: TI has announced that the device will be discontinued, and a lifetime-buy period is in effect.

NRND: Not recommended for new designs. Device is in production to support existing customers, but TI does not recommend using this part in a new design.

PREVIEW: Device has been announced but is not in production. Samples may or may not be available.

OBSELETE: TI has discontinued the production of the device.

⁽²⁾ Eco Plan - The planned eco-friendly classification: Pb-Free (RoHS), Pb-Free (RoHS Exempt), or Green (RoHS & no Sb/Br) - please check <http://www.ti.com/productcontent> for the latest availability information and additional product content details.

TBD: The Pb-Free/Green conversion plan has not been defined.

Pb-Free (RoHS): TI's terms "Lead-Free" or "Pb-Free" mean semiconductor products that are compatible with the current RoHS requirements

for all 6 substances, including the requirement that lead not exceed 0.1% by weight in homogeneous materials. Where designed to be soldered at high temperatures, TI Pb-Free products are suitable for use in specified lead-free processes.

Pb-Free (RoHS Exempt): This component has a RoHS exemption for either 1) lead-based flip-chip solder bumps used between the die and package, or 2) lead-based die adhesive used between the die and leadframe. The component is otherwise considered Pb-Free (RoHS compatible) as defined above.

Green (RoHS & no Sb/Br): TI defines "Green" to mean Pb-Free (RoHS compatible), and free of Bromine (Br) and Antimony (Sb) based flame retardants (Br or Sb do not exceed 0.1% by weight in homogeneous material)

(3) MSL, Peak Temp. -- The Moisture Sensitivity Level rating according to the JEDEC industry standard classifications, and peak solder temperature.

Important Information and Disclaimer:The information provided on this page represents TI's knowledge and belief as of the date that it is provided. TI bases its knowledge and belief on information provided by third parties, and makes no representation or warranty as to the accuracy of such information. Efforts are underway to better integrate information from third parties. TI has taken and continues to take reasonable steps to provide representative and accurate information but may not have conducted destructive testing or chemical analysis on incoming materials and chemicals. TI and TI suppliers consider certain information to be proprietary, and thus CAS numbers and other limited information may not be available for release.

In no event shall TI's liability arising out of such information exceed the total purchase price of the TI part(s) at issue in this document sold by TI to Customer on an annual basis.

TAPE AND REEL INFORMATION

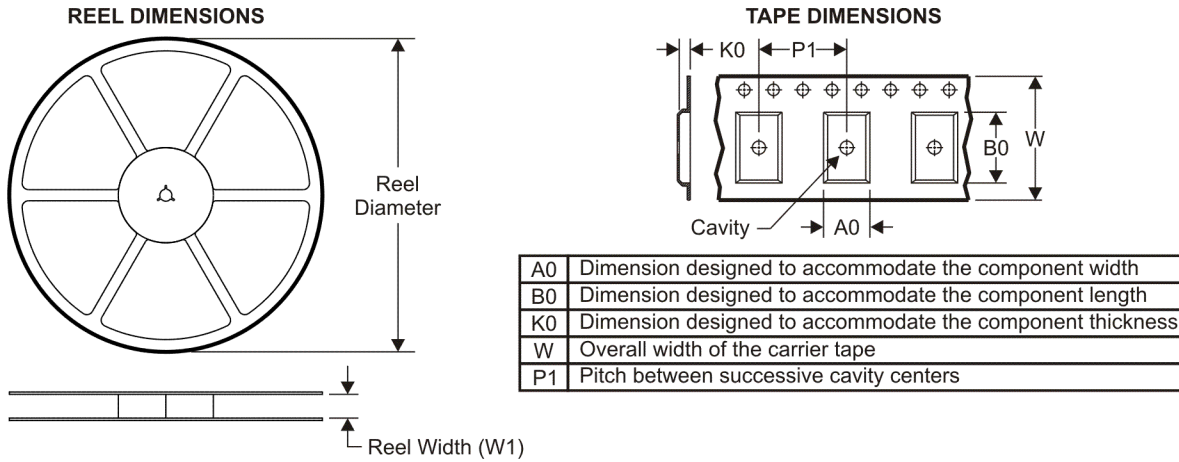

QUADRANT ASSIGNMENTS FOR PIN 1 ORIENTATION IN TAPE

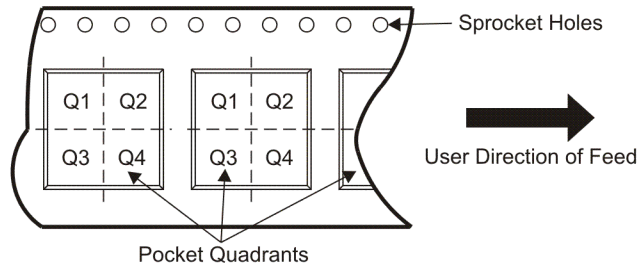

*All dimensions are nominal

Device	Package Type	Package Drawing	Pins	SPQ	Reel Diameter (mm)	Reel Width W1 (mm)	A0 (mm)	B0 (mm)	K0 (mm)	P1 (mm)	W (mm)	Pin1 Quadrant
THS3091DDAR	SO Power PAD	DDA	8	2500	330.0	12.4	6.4	5.2	2.1	8.0	12.0	Q1
THS3091DR	SOIC	D	8	2500	330.0	12.4	6.4	5.2	2.1	8.0	12.0	Q1
THS3095DDAR	SO Power PAD	DDA	8	2500	330.0	12.4	6.4	5.2	2.1	8.0	12.0	Q1
THS3095DR	SOIC	D	8	2500	330.0	12.4	6.4	5.2	2.1	8.0	12.0	Q1

TAPE AND REEL BOX DIMENSIONS

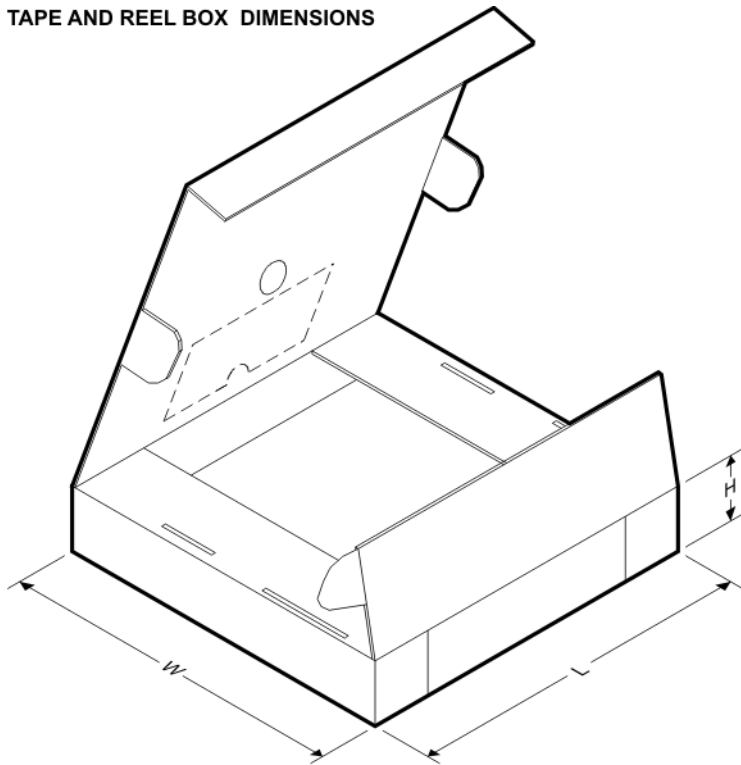

*All dimensions are nominal

Device	Package Type	Package Drawing	Pins	SPQ	Length (mm)	Width (mm)	Height (mm)
THS3091DDAR	SO PowerPAD	DDA	8	2500	346.0	346.0	29.0
THS3091DR	SOIC	D	8	2500	346.0	346.0	29.0
THS3095DDAR	SO PowerPAD	DDA	8	2500	346.0	346.0	29.0
THS3095DR	SOIC	D	8	2500	346.0	346.0	29.0

D (R-PDSO-G8)

PLASTIC SMALL-OUTLINE PACKAGE

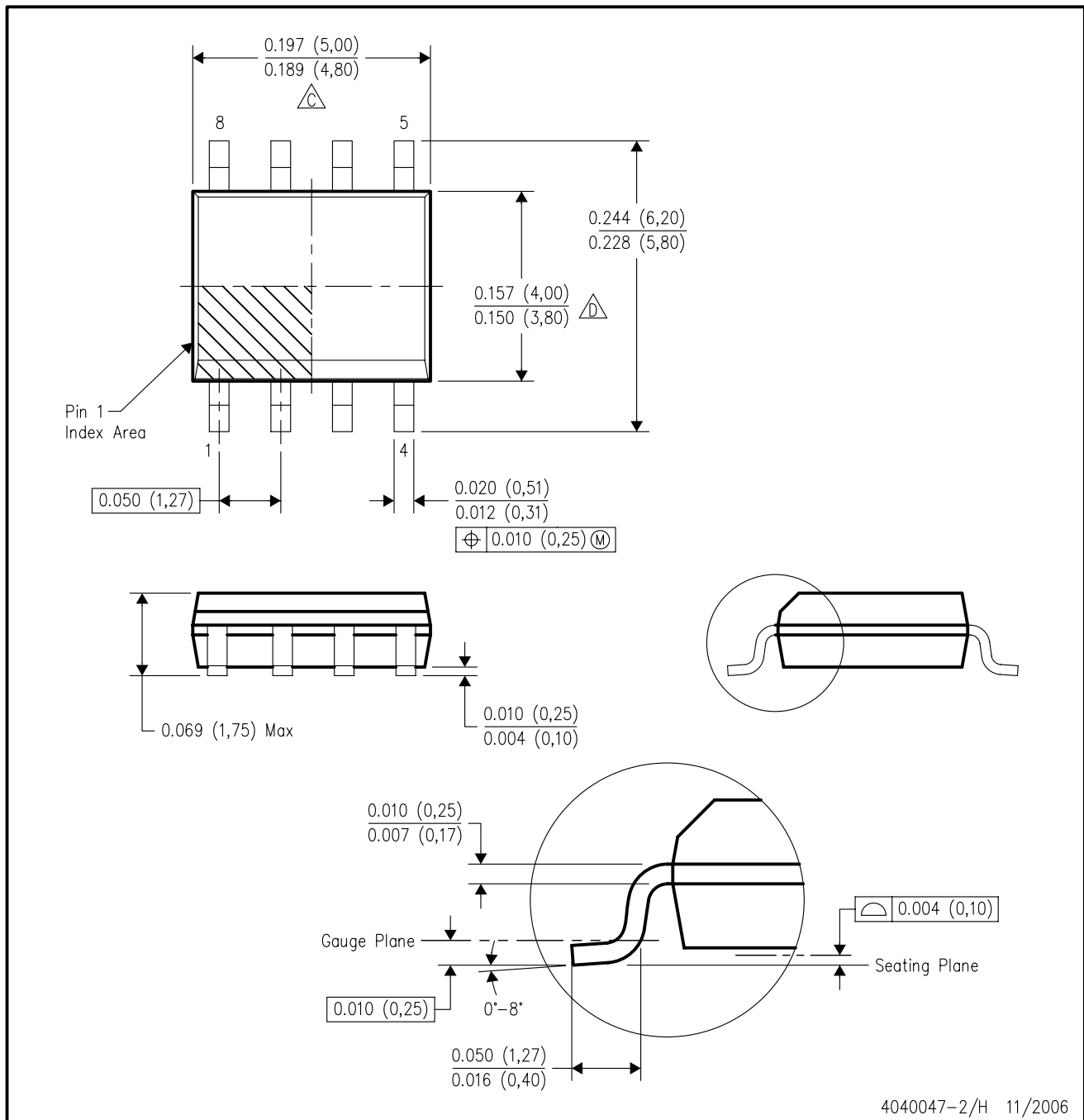

- NOTES:
- A. All linear dimensions are in inches (millimeters).
 - B. This drawing is subject to change without notice.
 - C. Body length does not include mold flash, protrusions, or gate burrs. Mold flash, protrusions, or gate burrs shall not exceed .006 (0,15) per end.
 - D. Body width does not include interlead flash. Interlead flash shall not exceed .017 (0,43) per side.
 - E. Reference JEDEC MS-012 variation AA.

DDA (R-PDSO-G8)

PowerPAD™ PLASTIC SMALL-OUTLINE PACKAGE

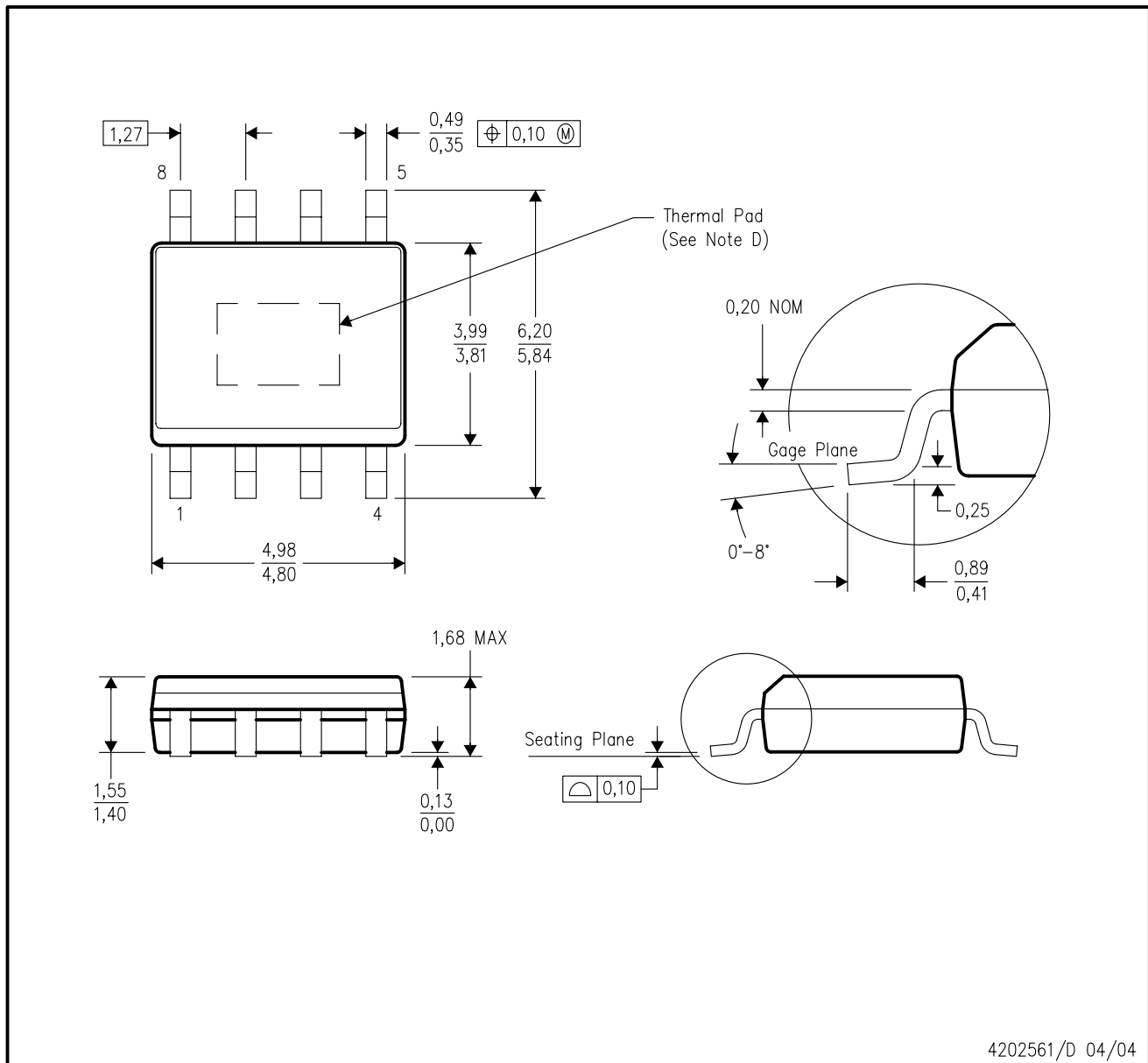

- NOTES:
- All linear dimensions are in millimeters.
 - This drawing is subject to change without notice.
 - Body dimensions do not include mold flash or protrusion not to exceed 0,15.
 - This package is designed to be soldered to a thermal pad on the board. Refer to Technical Brief, PowerPad Thermally Enhanced Package, Texas Instruments Literature No. SLMA002 for information regarding recommended board layout. This document is available at www.ti.com <<http://www.ti.com>>.

PowerPAD is a trademark of Texas Instruments.

THERMAL INFORMATION

This PowerPAD™ package incorporates an exposed thermal pad that is designed to be attached directly to an external heatsink. The thermal pad must be soldered directly to the printed circuit board (PCB). After soldering, the PCB can be used as a heatsink. In addition, through the use of thermal vias, the thermal pad can be attached directly to the appropriate copper plane shown in the electrical schematic for the device, or alternatively, can be attached to a special heatsink structure designed into the PCB. This design optimizes the heat transfer from the integrated circuit (IC).

For additional information on the PowerPAD package and how to take advantage of its heat dissipating abilities, refer to Technical Brief, PowerPAD Thermally Enhanced Package, Texas Instruments Literature No. SLMA002 and Application Brief, PowerPAD Made Easy, Texas Instruments Literature No. SLMA004. Both documents are available at www.ti.com.

The exposed thermal pad dimensions for this package are shown in the following illustration.

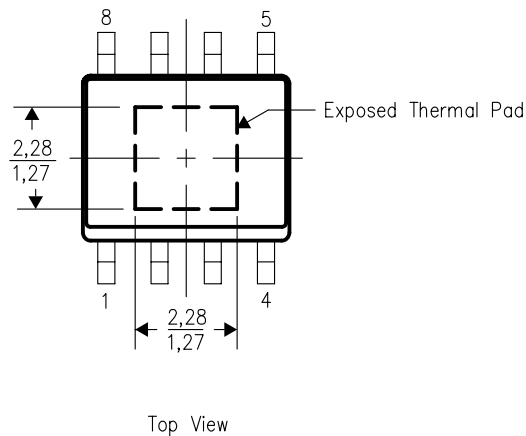

NOTE: All linear dimensions are in millimeters

Exposed Thermal Pad Dimensions

DDA (R-PDSO-G8) PowerPAD™

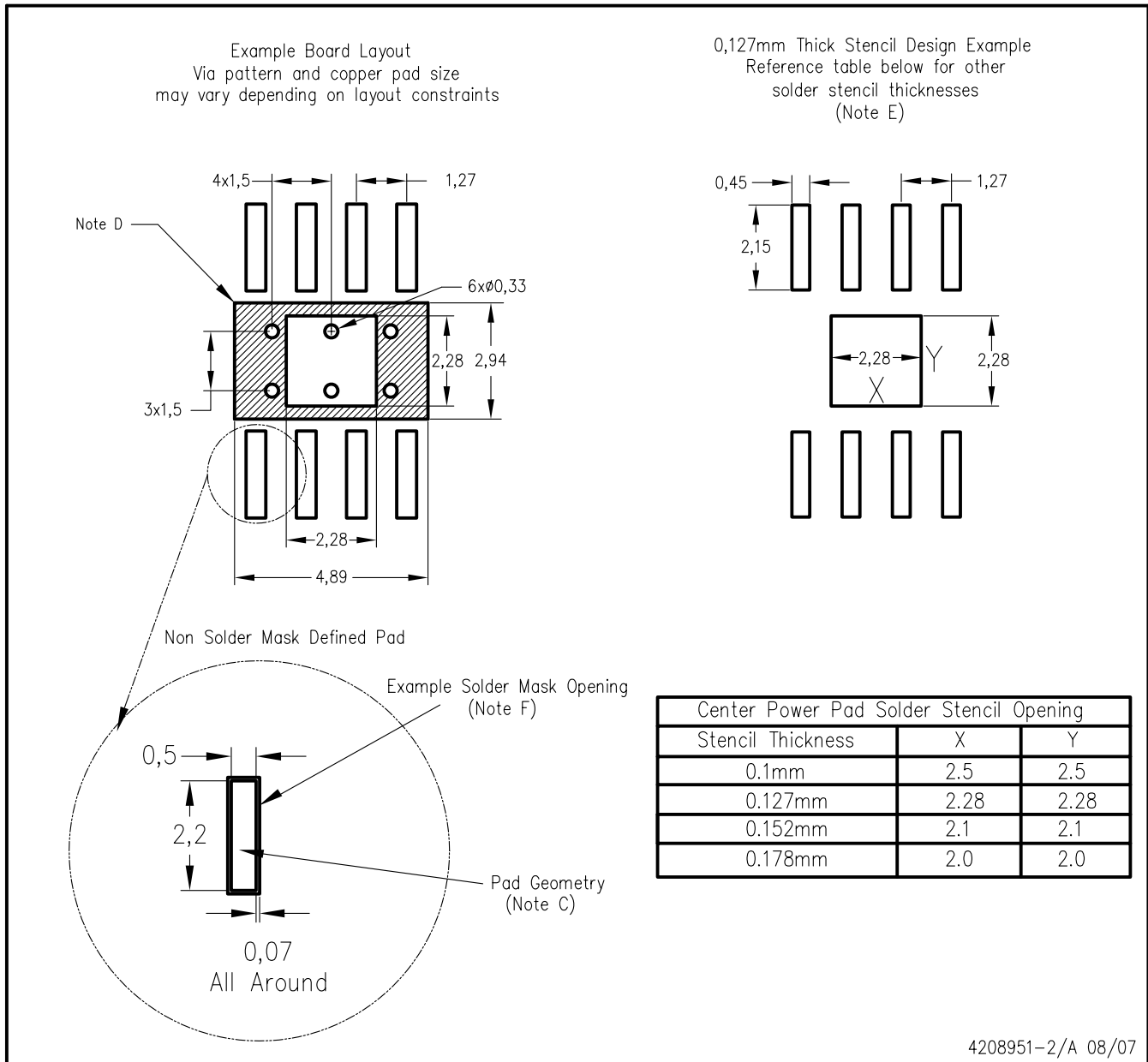

4208951-2/A 08/07

- NOTES:
- A. All linear dimensions are in millimeters.
 - B. This drawing is subject to change without notice.
 - C. Publication IPC-7351 is recommended for alternate designs.
 - D. This package is designed to be soldered to a thermal pad on the board. Refer to Technical Brief, PowerPAD Thermally Enhanced Package, Texas Instruments Literature No. SLMA002, SLMA004, and also the Product Data Sheets for specific thermal information, via requirements, and recommended board layout. These documents are available at www.ti.com <<http://www.ti.com>>.
 - E. Laser cutting apertures with trapezoidal walls and also rounding corners will offer better paste release. Customers should contact their board assembly site for stencil design recommendations. Refer to IPC 7525 for stencil design considerations.
 - F. Customers should contact their board fabrication site for recommended solder mask tolerances and via tenting options for vias placed in the thermal pad.

PowerPAD is a trademark of Texas Instruments.

IMPORTANT NOTICE

Texas Instruments Incorporated and its subsidiaries (TI) reserve the right to make corrections, modifications, enhancements, improvements, and other changes to its products and services at any time and to discontinue any product or service without notice. Customers should obtain the latest relevant information before placing orders and should verify that such information is current and complete. All products are sold subject to TI's terms and conditions of sale supplied at the time of order acknowledgment.

TI warrants performance of its hardware products to the specifications applicable at the time of sale in accordance with TI's standard warranty. Testing and other quality control techniques are used to the extent TI deems necessary to support this warranty. Except where mandated by government requirements, testing of all parameters of each product is not necessarily performed.

TI assumes no liability for applications assistance or customer product design. Customers are responsible for their products and applications using TI components. To minimize the risks associated with customer products and applications, customers should provide adequate design and operating safeguards.

TI does not warrant or represent that any license, either express or implied, is granted under any TI patent right, copyright, mask work right, or other TI intellectual property right relating to any combination, machine, or process in which TI products or services are used. Information published by TI regarding third-party products or services does not constitute a license from TI to use such products or services or a warranty or endorsement thereof. Use of such information may require a license from a third party under the patents or other intellectual property of the third party, or a license from TI under the patents or other intellectual property of TI.

Reproduction of TI information in TI data books or data sheets is permissible only if reproduction is without alteration and is accompanied by all associated warranties, conditions, limitations, and notices. Reproduction of this information with alteration is an unfair and deceptive business practice. TI is not responsible or liable for such altered documentation. Information of third parties may be subject to additional restrictions.

Resale of TI products or services with statements different from or beyond the parameters stated by TI for that product or service voids all express and any implied warranties for the associated TI product or service and is an unfair and deceptive business practice. TI is not responsible or liable for any such statements.

TI products are not authorized for use in safety-critical applications (such as life support) where a failure of the TI product would reasonably be expected to cause severe personal injury or death, unless officers of the parties have executed an agreement specifically governing such use. Buyers represent that they have all necessary expertise in the safety and regulatory ramifications of their applications, and acknowledge and agree that they are solely responsible for all legal, regulatory and safety-related requirements concerning their products and any use of TI products in such safety-critical applications, notwithstanding any applications-related information or support that may be provided by TI. Further, Buyers must fully indemnify TI and its representatives against any damages arising out of the use of TI products in such safety-critical applications.

TI products are neither designed nor intended for use in military/aerospace applications or environments unless the TI products are specifically designated by TI as military-grade or "enhanced plastic." Only products designated by TI as military-grade meet military specifications. Buyers acknowledge and agree that any such use of TI products which TI has not designated as military-grade is solely at the Buyer's risk, and that they are solely responsible for compliance with all legal and regulatory requirements in connection with such use.

TI products are neither designed nor intended for use in automotive applications or environments unless the specific TI products are designated by TI as compliant with ISO/TS 16949 requirements. Buyers acknowledge and agree that, if they use any non-designated products in automotive applications, TI will not be responsible for any failure to meet such requirements.

Following are URLs where you can obtain information on other Texas Instruments products and application solutions:

Products

Amplifiers	amplifier.ti.com
Data Converters	dataconverter.ti.com
DSP	dsp.ti.com
Clocks and Timers	www.ti.com/clocks
Interface	interface.ti.com
Logic	logic.ti.com
Power Mgmt	power.ti.com
Microcontrollers	microcontroller.ti.com
RFID	www.ti-rfid.com
RF/IF and ZigBee® Solutions	www.ti.com/lprf

Applications

Audio	www.ti.com/audio
Automotive	www.ti.com/automotive
Broadband	www.ti.com/broadband
Digital Control	www.ti.com/digitalcontrol
Medical	www.ti.com/medical
Military	www.ti.com/military
Optical Networking	www.ti.com/opticalnetwork
Security	www.ti.com/security
Telephony	www.ti.com/telephony
Video & Imaging	www.ti.com/video
Wireless	www.ti.com/wireless

Mailing Address: Texas Instruments, Post Office Box 655303, Dallas, Texas 75265
Copyright © 2008, Texas Instruments Incorporated