

VERTICAL DEFLECTION OUTPUT CIRCUIT

- POWER AMPLIFIER
- FLYBACK GENERATOR
- THERMAL PROTECTION

DESCRIPTION

The TDA9302H is a monolithic integrated circuit in HEPTAWATT™ package. It is a high efficiency power booster for direct driving of vertical windings of TV yokes. It is intended for use in Color and B & W television as well as in monitors and displays.

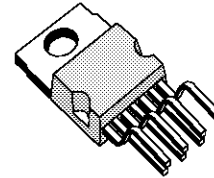

HEPTAWATT
(Plastic Package)

ORDER CODE : TDA9302H

PIN CONNECTIONS (top view)

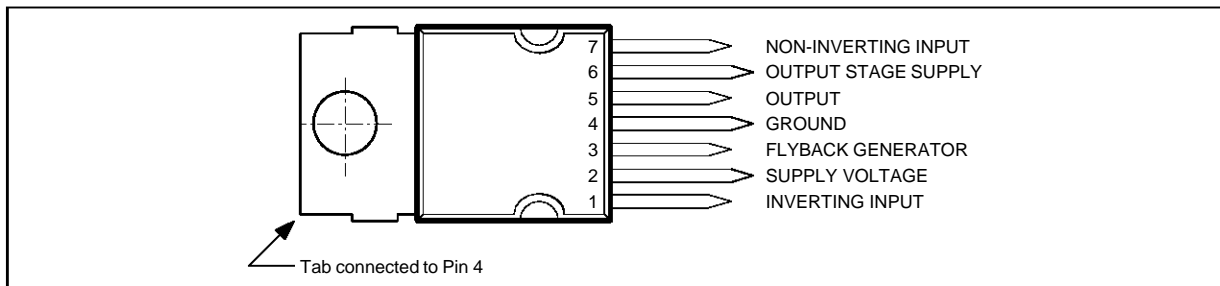

9302H-01.EPS

BLOCK DIAGRAM

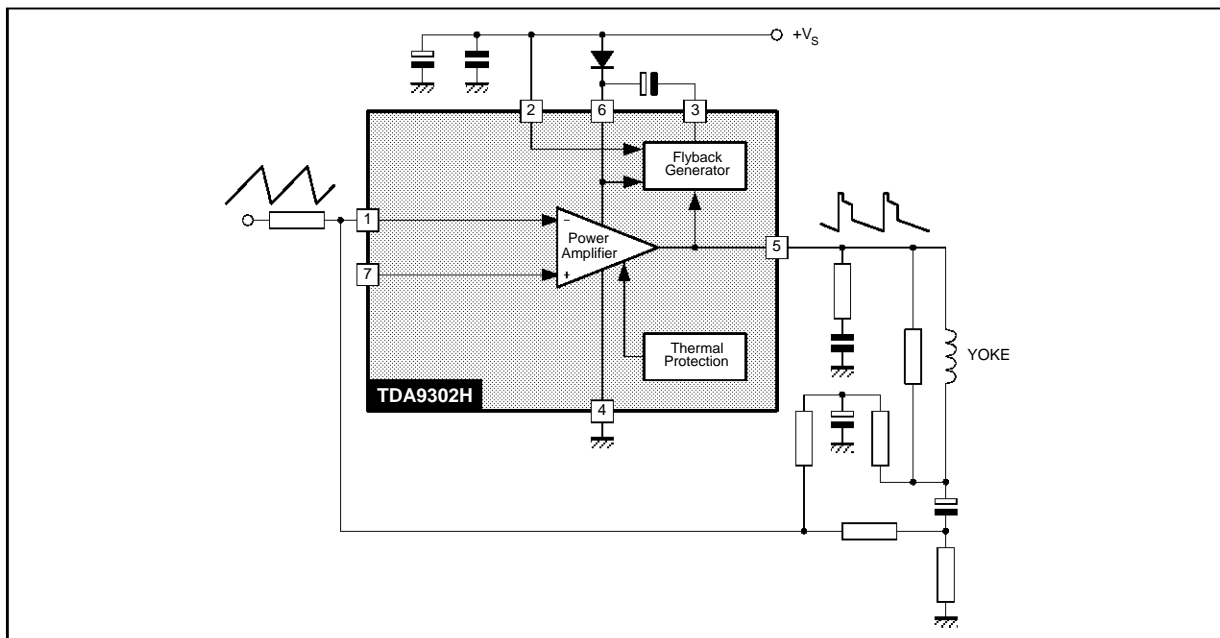

9302H-02.EPS

TDA9302H

ABSOLUTE MAXIMUM RATINGS AT $T_A = 25^\circ\text{C}$

Symbol	Parameter	Value	Unit
V_S	Supply Voltage (pin 2)	35	V
V_5, V_6	Flyback Peak Voltage	60	V
V_3	Voltage at Pin 3	+ V_S	
V_1, V_7	Amplifier Input Voltage	+ V_S - 0.5	V
I_o	Deflection Output Current	± 1.8	A
I_3	Pin 3 DC Current at $V_5 < V_2$	100	mA
P_{tot}	Total Power Dissipation at $T_{case} = 90^\circ\text{C}$	15	W
T_{stg}, T_j	Storage and Junction Temperature	- 40, +150	$^\circ\text{C}$

9302H-01.TBL

THERMAL DATA

Symbol	Parameter	Value	Unit
$R_{th(j-c)}$	Thermal Resistance Junction-case	Max. 4	$^\circ\text{C/W}$

9302H-02.TBL

RECOMMENDED OPERATING CHARACTERISTICS AT $T_A = 25^\circ\text{C}$

Symbol	Parameter	Test Conditions	Min.	Typ.	Max.	Unit
V_{2M}	Recommended Supply Voltage			25		V
V_{2R}	Operating Supply Voltage Range		15		30	V
I_{5PP}	Deflection Output Current				2	App

9302H-03.TBL

ELECTRICAL CHARACTERISTICS

(refer to the test circuits, $V_S = 35\text{V}$, $T_{amb} = 25^\circ\text{C}$ unless otherwise specified)

Symbol	Parameter	Test Conditions	Min.	Typ.	Max.	Unit	Fig.
I_2	Pin 2 Quiescent Current	$I_3 = 0, I_5 = 0$			16	mA	1a
I_6	Pin 6 Quiescent Current	$I_3 = 0, I_5 = 0$			36	mA	1a
I_1	Amplifier Input Bias Current	$V_1 = 1\text{V}, V_7 = 2\text{V}$		- 0.1	- 1	μA	1a
		$V_1 = 2\text{V}, V_7 = 1\text{V}$		- 0.1	- 1	μA	1a
V_{3L}	Pin 3 Saturation Voltage to GND	$I_3 = 20\text{mA}$		1	1.5	V	1c
V_5	Quiescent Output Voltage	$V_S = 35\text{V}, R_a = 39\text{k}\Omega$		18		V	1d
V_{5L}	Output Saturation Voltage to GND	$I_5 = 1\text{A}$		0.9	1.3	V	1c
		$I_5 = 0.7\text{A}$		0.7	1	V	1c
V_{5H}	Output Saturation Voltage to Supply	- $I_5 = 1\text{A}$		1.5	2	V	1b
		- $I_5 = 0.7\text{A}$		1.3	1.8	V	1b
T_j	Junction Temperature for Thermal Shut Down			140		$^\circ\text{C}$	

9302H-04.TBL

Figure 1 : DC Test Circuits.

Figure 1 a : Measurement of I_1 ; I_2 ; I_6

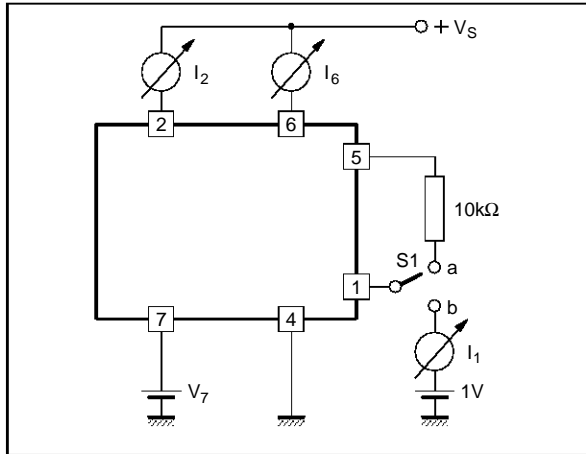

9302H-03.EPS

S₁ : (a) I_2 and I_6 ; (b) I_1

Figure 1 b : Measurement of V_{5H}

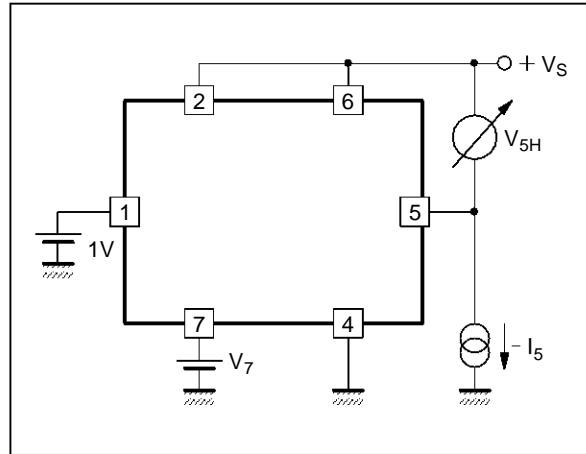

9302H-04.EPS

Figure 1 c : Measurement of V_{3L} ; V_{5L}

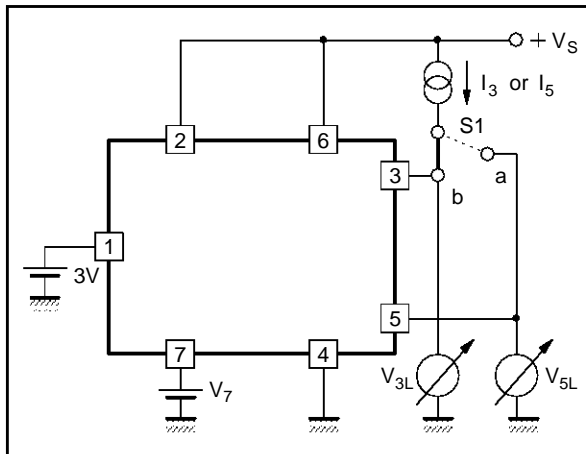

9302H-05.EPS

S₁ : (a) V_{3L} ; (b) V_{5L}

Figure 1 d : Measurement of V_5

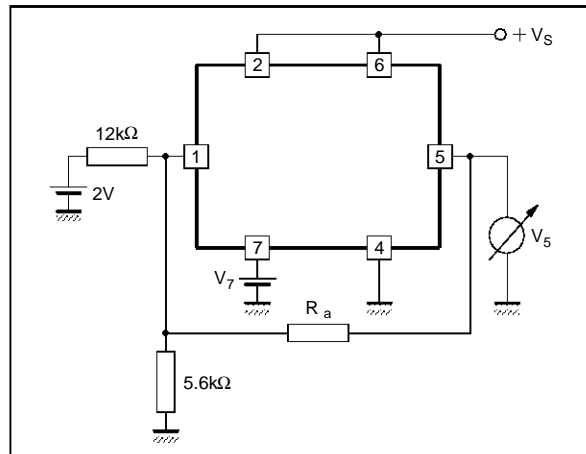

9302H-06.EPS

Figure 2 : AC Test Circuit

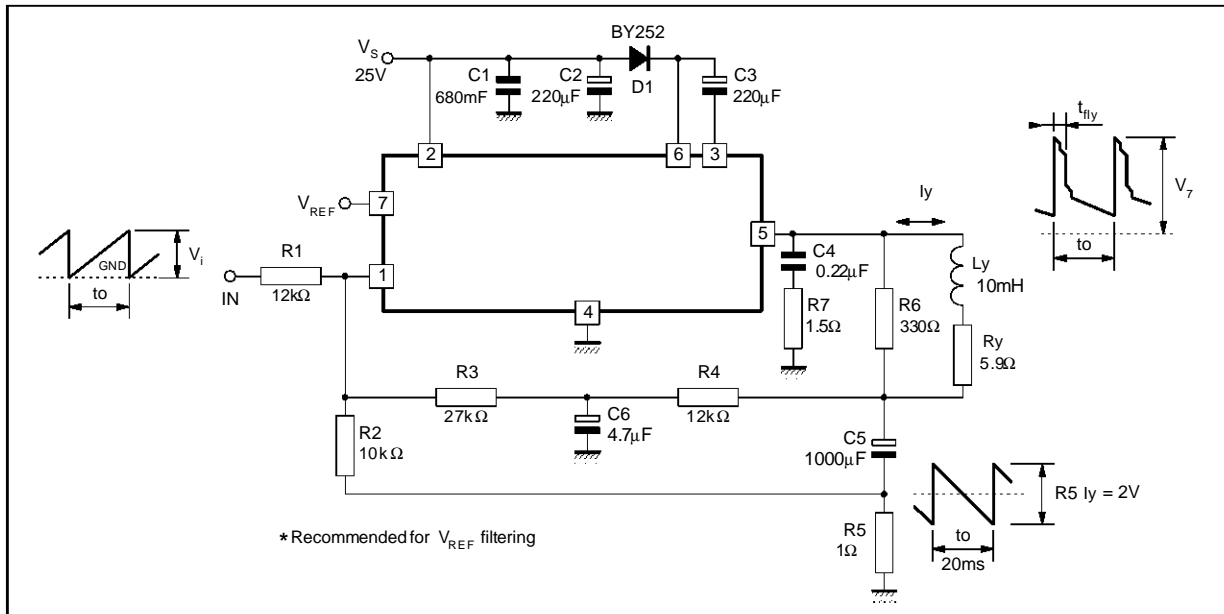

9302H-07.EPS

MOUNTING INSTRUCTIONS

The power dissipated in the circuit must be removed by adding an external heatsink. Thanks to the HEPTAWATT™ package attaching the heatsink is very simple, a screw or a compression spring (clip) being sufficient.

Between the heatsink and the package it is better to insert a layer of silicon grease, to optimize the thermal contact ; no electrical isolation is needed between the two surfaces, since the tab is connected to Pin 4 which is ground.

Figure 3 : Mounting Examples

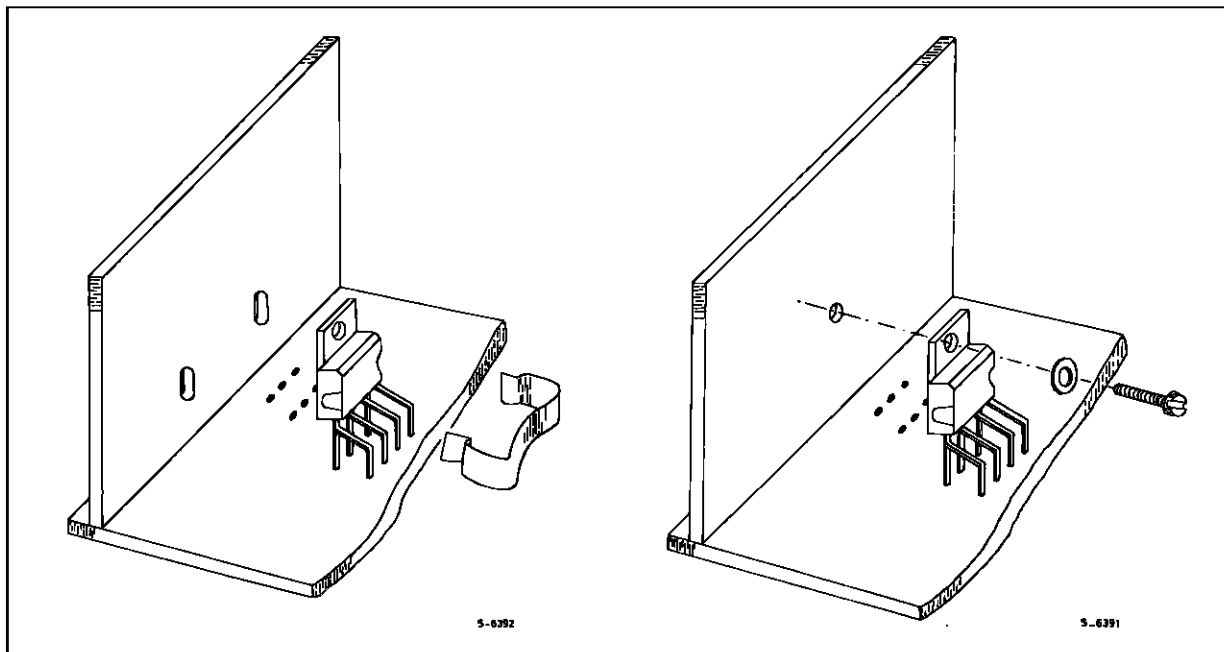

9302H-08.EPS/9302H-09.EPS

