

5.1V +12V DISABLE VOLTAGE REGULATOR

- OUTPUT CURRENTS UP TO 1A
- FIXED PRECISION OUTPUT 1 VOLTAGE
5.1V +/- 2%
- FIXED PRECISION OUTPUT 2 VOLTAGE
12V +/- 2%
- OUTPUT 1 WITH DISABLE BY TTL INPUT
- OUTPUT 2 WITH DISABLE BY TTL INPUT
- SHORT CIRCUIT PROTECTION AT BOTH
OUTPUTS
- THERMAL PROTECTION
- LOW DROP OUTPUT VOLTAGE

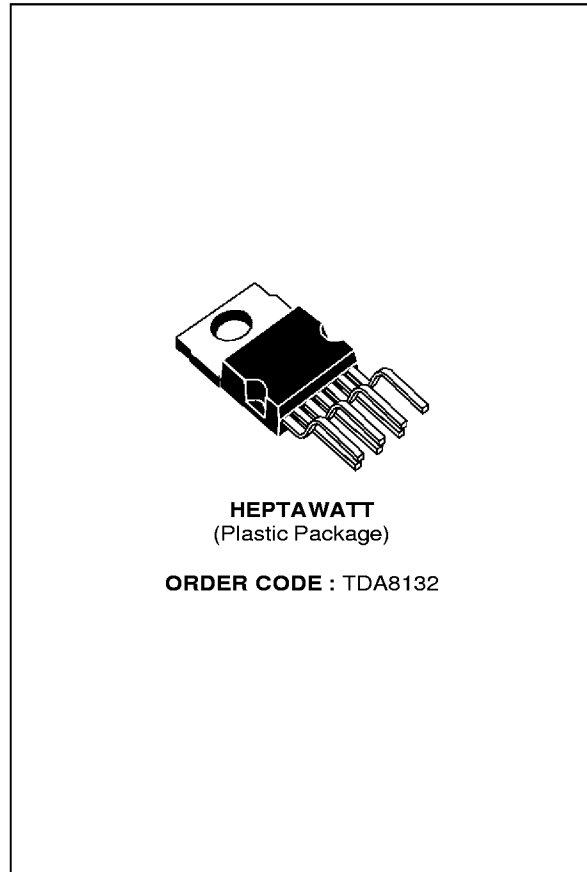

DESCRIPTION

The TDA8132 is a monolithic dual positive voltage regulator designed to provide fixed precision output voltages of 5.1V and 12V at currents up to 1A. Each output can be disabled separately by a TTL input. Short circuit and thermal protections are included.

PIN CONNECTIONS

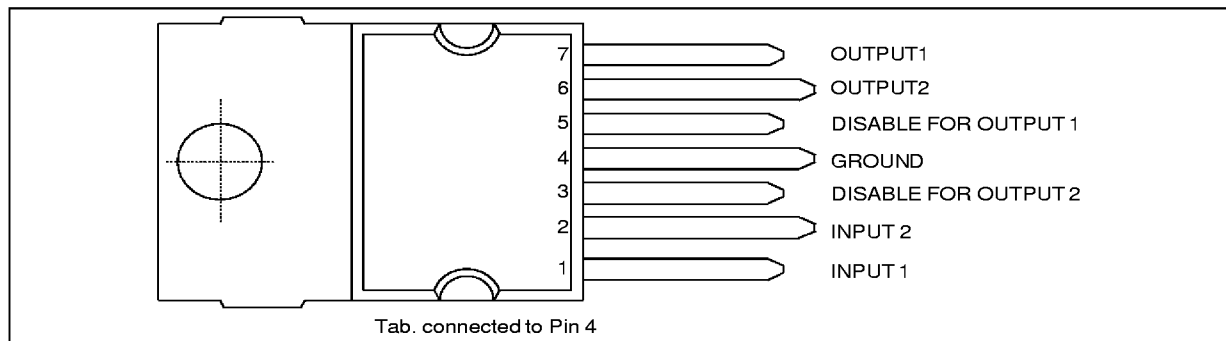

TDA8132

BLOCK DIAGRAM

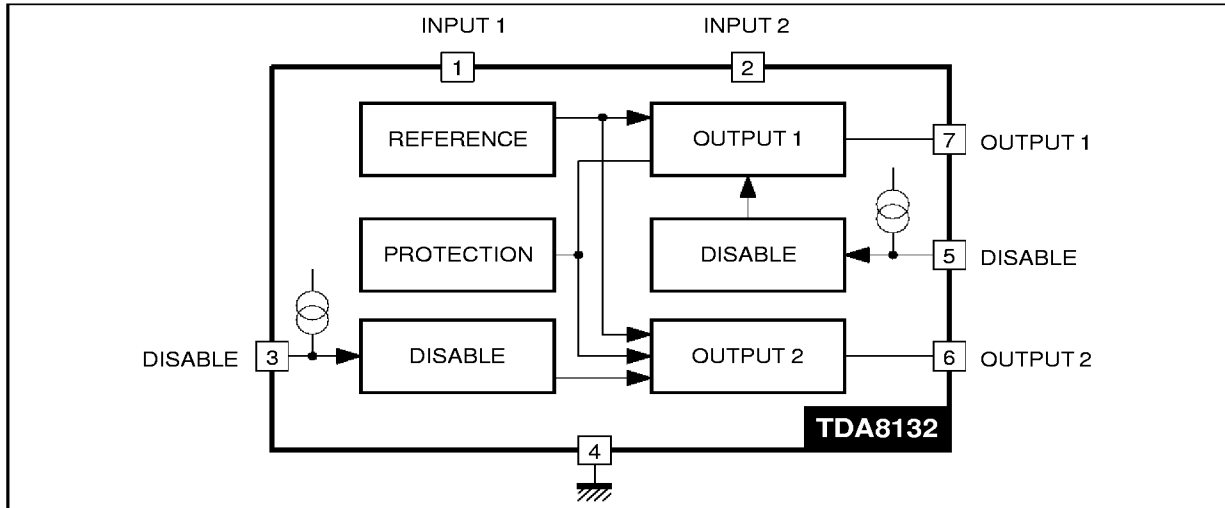

8132-02-EFS

CIRCUIT DESCRIPTION

The TDA8132 is a dual voltage regulator with separate Disable for each output.

The two regulation parts are supplied from one voltage reference circuit trimmed by zener zap during EWS test.

Since the supply voltage of this last is connected at Pin 1 (V_{IN1}), the regulator 2 will not work if Pin 1 is

not supplied.

The outputs stage have been realized in darlington configuration with a drop typical 1.2V.

For each output a disable circuit switches-off this output if a voltage lower than 0.8V is applied at corresponding Pin (Pin 3 for output 2, Pin 5 for output 1).

ABSOLUTE MAXIMUM RATINGS

Symbol	Parameter	Value	Unit
V_{IN}	DC Input Voltage Pin 1	20	V
V_{DIS}	Disable Input Voltage Pins 3-5	20	V
$I_{O1,2}$	Output Currents	Internally Limited	
P_t	Power Dissipation	Internally Limited	
T_{stg}	Storage Temperature	-65, +150	°C
T_j	Junction Temperature	0, +150	°C

8132-01-TBL

THERMAL DATA

Symbol	Parameter	Value	Unit
$R_{th(j-c)}$	Maximum Thermal Resistance Junction-case	3	°C/W
T_j	Maximum Recommended Junction Temperature	130	°C

8132-02-TBL

ELECTRICAL CHARACTERISTICS ($V_{IN1} = 7V$, $V_{IN2} = 14V$, $T_j = 25^\circ C$, unless otherwise specified)

Symbol	Parameter	Test Conditions	Min.	Typ.	Max.	Unit
V_{O1}	Output Voltage	$I_{O1} = 10mA$	5	5.1	5.2	V
V_{O2}	Output Voltage	$I_{O2} = 10mA$	11.76	12	12.24	V
V_{O1} V_{O2}	Output Voltage	$5mA < I_{O1,2} < 750mA$ $7V < V_{IN1} < 14V$ $14 < V_{IN2} < 18V$	4.9 11.5		5.3 12.5	V V
$V_{IO1,2}$	Dropout Voltage	$I_{O1,2} = 750mA$ $I_{O1,2} = 1A$			1.4 2	V V
$V_{O1,2LI}$	Line Regulation	$7V < V_{IN1} < 14V$ $14 < V_{IN2} < 18V$ $I_{O1,2} = 200mA$			50 120	mV mV
$V_{O1,2LO}$	Load Regulation	$5mA < I_{O1} < 0.6A$ $5mA < I_{O2} < 0.6A$			100 250	mV mV
I_Q	Quiescent Current	$I_{O1} = 10mA$ Output 2 Disabled			2	mA
$K_{O1,2}$	Output Voltage Thermal Drift	$T_j = 0 \text{ to } 125^\circ C$ $K_O = \frac{\Delta V_O \cdot 10^6}{\Delta T \cdot V_O}$		100		ppm/ $^\circ C$
$I_{O1,2SC}$	Short Circuit Output Current	$V_{IN1} = 7V$, $V_{IN2} = 14V$ $V_{IN1,2} = 16V$ (see Note)			1.6 1	A A
V_{DISH}	Disable Voltage High (corresponding out active)		2			V
V_{DISL}	Disable Voltage Low (corresponding out disabled)				0.8	V
I_{DIS}	Disable Bias Current	$0V < V_{DIS} < 7V$	-30		2	μA
T_{jsd}	Junction Temperature for Thermal Shut Down			145		$^\circ C$

Note : Safe permanent short-circuit is only guaranteed for input voltages up to 16V.

TYPICAL APPLICATION

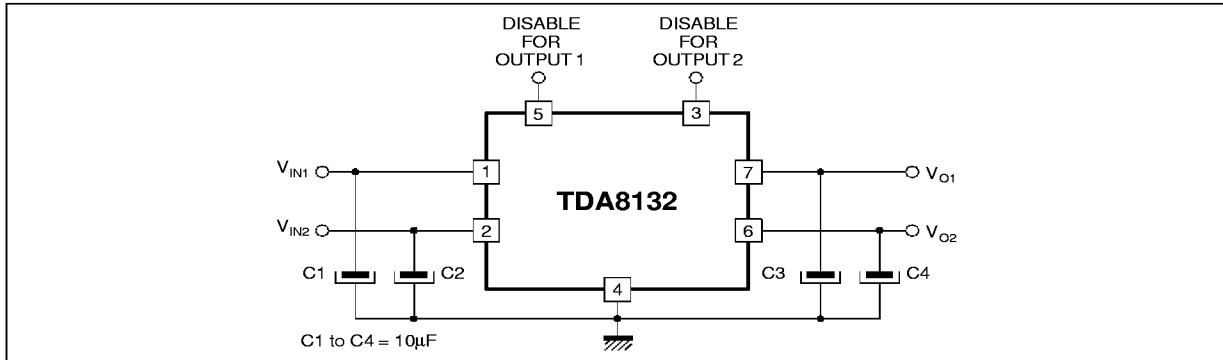

PACKAGE MECHANICAL DATA : 9 PINS - PLASTIC HEPTAWATT

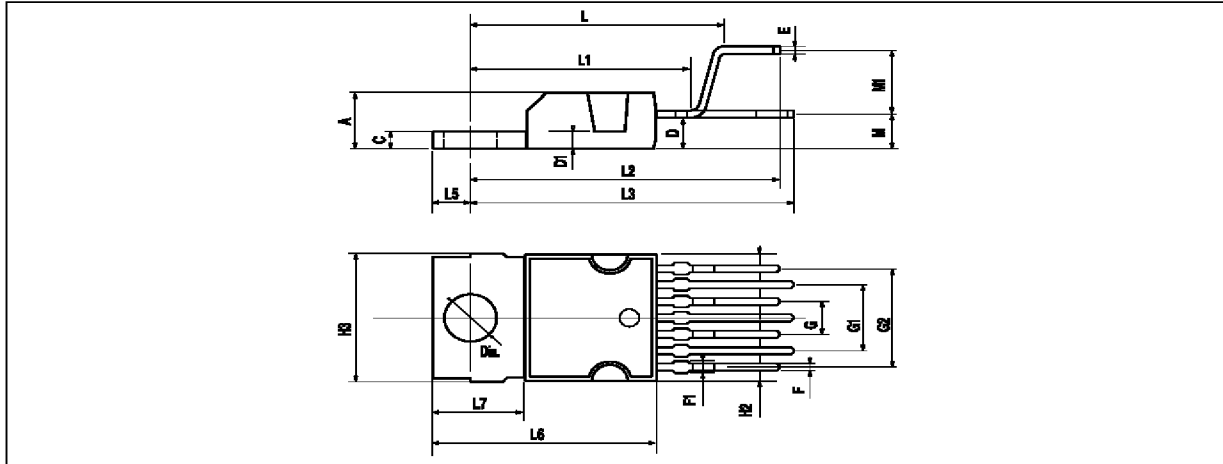

PM-HEPTV.EPS

Dimensions	Millimeters			Inches		
	Min.	Typ.	Max.	Min.	Typ.	Max.
A			4.8			0.189
C			1.37			0.054
D	2.4		2.8	0.094		0.110
D1	1.2		1.35	0.047		0.053
E	0.35		0.55	0.014		0.022
F	0.6		0.8	0.024		0.031
F1			0.9			0.035
G	2.41	2.54	2.67	0.095	0.100	0.105
G1	4.91	5.08	5.21	0.193	0.200	0.205
G2	7.49	7.62	7.8	0.295	0.300	0.307
H2			10.4			0.409
H3	10.05		10.4	0.396		0.409
L		16.97			0.668	
L1		14.92			0.587	
L2		21.54			0.848	
L3		22.62			0.891	
L5	2.6		3	0.102		0.118
L6	15.1		15.8	0.594		0.622
L7	6		6.6	0.236		0.260
M		2.8			0.110	
M1		5.08			0.200	
Dia.	3.65		3.85	0.144		0.152

HEPTV.TBL

Information furnished is believed to be accurate and reliable. However, SGS-THOMSON Microelectronics assumes no responsibility for the consequences of use of such information nor for any infringement of patents or other rights of third parties which may result from its use. No licence is granted by implication or otherwise under any patent or patent rights of SGS-THOMSON Microelectronics. Specifications mentioned in this publication are subject to change without notice. This publication supersedes and replaces all information previously supplied. SGS-THOMSON Microelectronics products are not authorized for use as critical components in life support devices or systems without express written approval of SGS-THOMSON Microelectronics.

© 1996 SGS-THOMSON Microelectronics - All Rights Reserved

Purchase of I²C Components of SGS-THOMSON Microelectronics, conveys a license under the Philips I²C Patent. Rights to use these components in a I²C system, is granted provided that the system conforms to the I²C Standard Specifications as defined by Philips.

SGS-THOMSON Microelectronics GROUP OF COMPANIES

Australia - Brazil - China - France - Germany - Hong Kong - Italy - Japan - Korea - Malaysia - Malta - Morocco
The Netherlands - Singapore - Spain - Sweden - Switzerland - Taiwan - Thailand - United Kingdom - U.S.A.