

20W BRIDGE AMPLIFIER FOR CAR RADIO

High output power : $P_O = 10 + 10 \text{ W}@R_L = 2\Omega$,
 $d = 10\%$; $P_O = 20\text{W}@R_L = 4\Omega$, $d = 1\%$.

High reliability of the chip and package with additional complete safety during operation thanks to protection against :

- OUTPUT DC AND AC SHORT CIRCUIT TO GROUND
- OVERRATING CHIP TEMPERATURE
- LOAD DUMP VOLTAGE SURGE
- FORTUITOUS OPEN GROUND
- VERY INDUCTIVE LOADS

Flexibility in use : bridge or stereo booster amplifiers with or without bootstrap and with programmable gain and bandwidth.

Space and cost saving : very low number of external components, very simple mounting system with no electrical isolation between the package and the heatsink (one screw only).

In addition, the circuit offers **loudspeaker protection** during short circuit for one wire to ground.

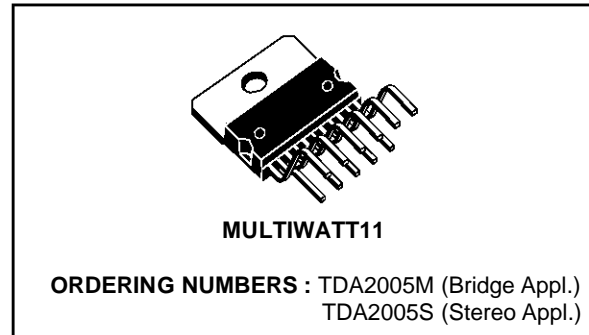

DESCRIPTION

The TDA2005 is class B dual audio power amplifier in MULTIWATT® package specifically designed for car radio application : **power booster amplifiers** are easily designed using this device that provides a high current capability (up to 3.5 A) and that can drive very low impedance loads (down to 1.6Ω in stereo applications) obtaining an output power of more than 20 W (bridge configuration).

ABSOLUTE MAXIMUM RATINGS

Symbol	Parameter	Value	Unit
V_s	Operating Supply Voltage	18	V
V_s	DC Supply Voltage	28	V
V_s	Peak Supply Voltage (for 50 ms)	40	V
I_o (*)	Output Peak Current (non repetitive $t = 0.1 \text{ ms}$)	4.5	A
I_o (*)	Output Peak Current (repetitive $f \geq 10 \text{ Hz}$)	3.5	A
P_{tot}	Power Dissipation at $T_{case} = 60^\circ\text{C}$	30	W
T_{stg}, T_j	Storage and Junction Temperature	- 40 to 150	$^\circ\text{C}$

(*) The max. output current is internally limited.

PIN CONNECTION

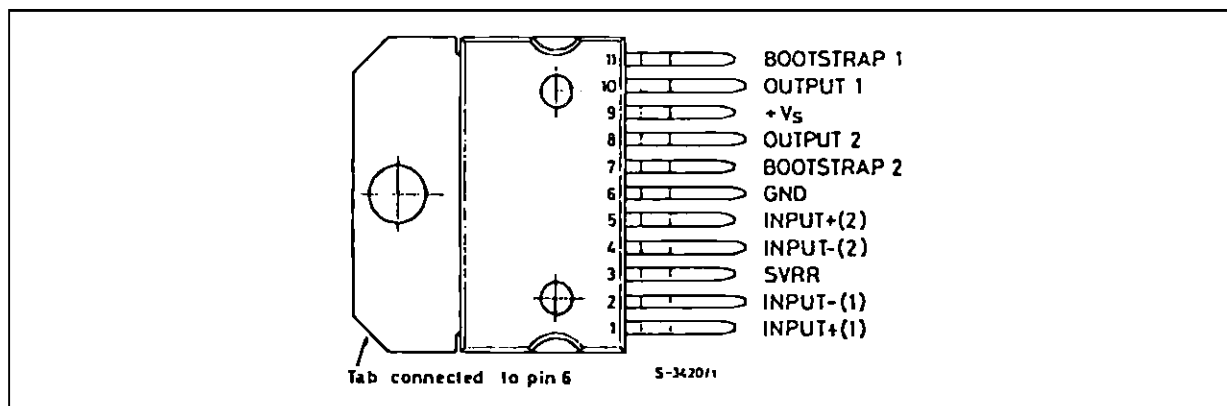

SCHEMATIC DIAGRAM

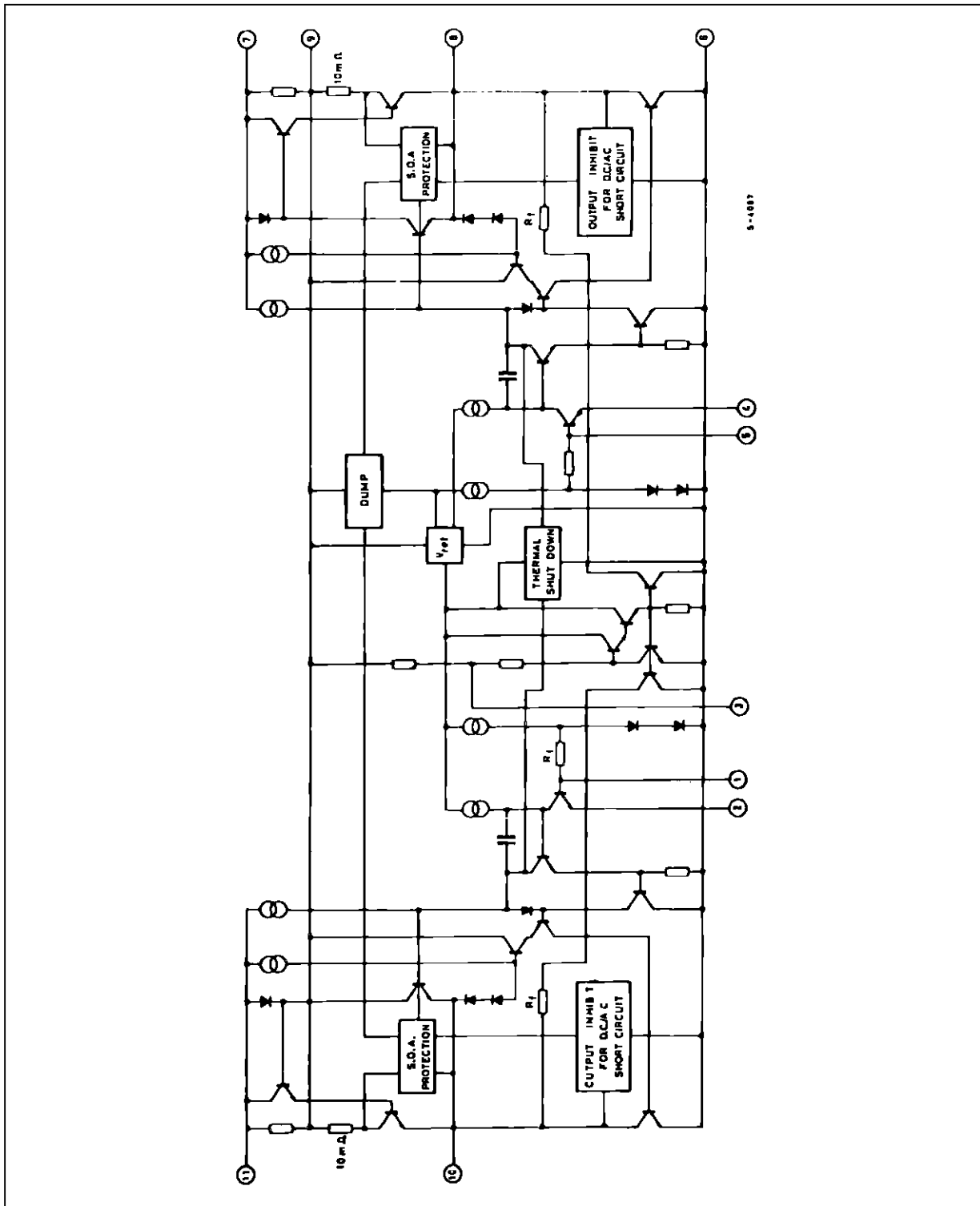

THERMAL DATA

Symbol	Parameter	Value	Unit
R _{th j-case}	Thermal Resistance Junction-case	Max. 3	°C/W

BRIDGE AMPLIFIER APPLICATION (TDA2005M)

Figure 1 : Test and Application Circuit (Bridge amplifier)

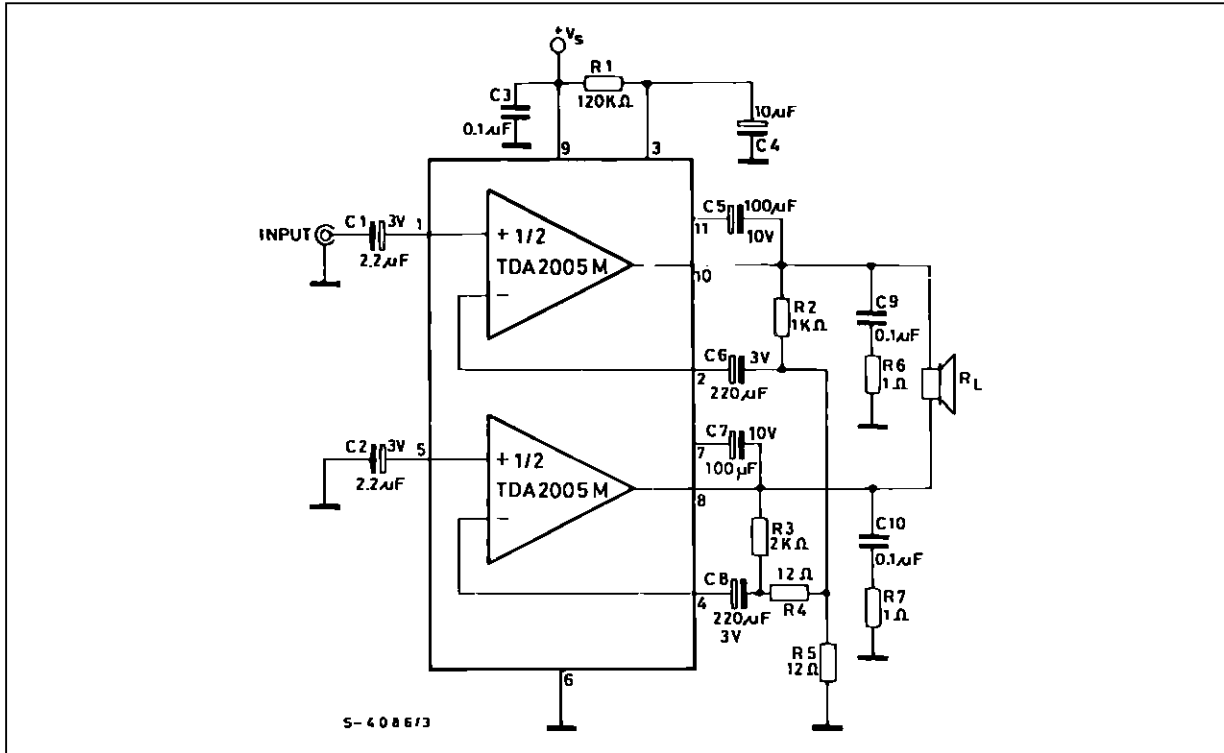
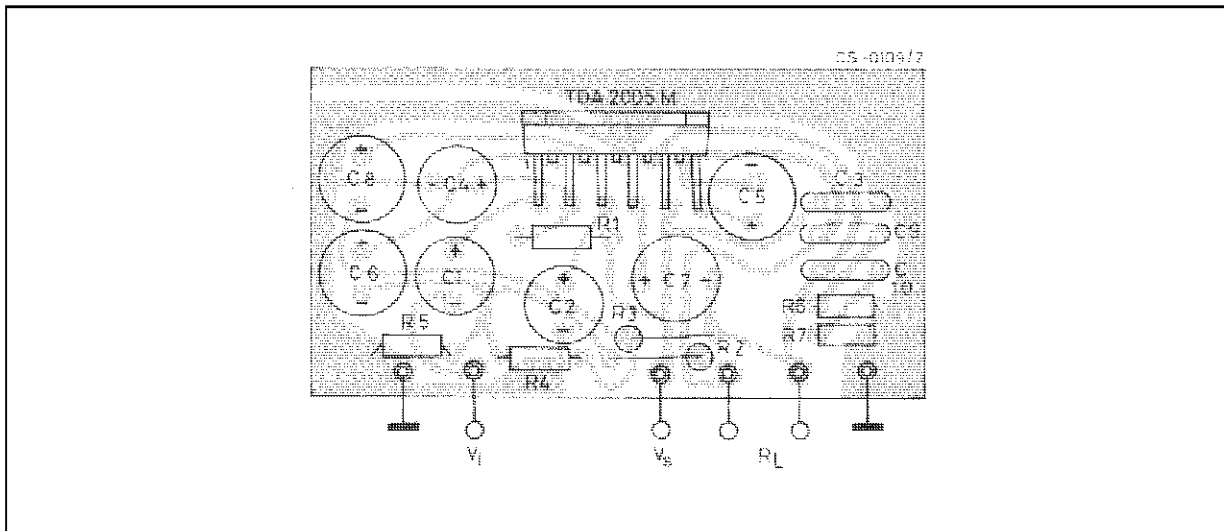

Figure 2 : P.C. Board and Components Layout of Figure 1 (1:1 scale)



TDA2005

ELECTRICAL CHARACTERISTICS (refer to the **Bridge** application circuit, $T_{amb} = 25^{\circ}\text{C}$, $G_V = 50\text{dB}$, $R_{th}(\text{heatsink}) = 4^{\circ}\text{C/W}$, unless otherwise specified)

Symbol	Parameter	Test Conditions	Min.	Typ.	Max.	Unit
V_s	Supply Voltage		8		18	V
V_{os}	Output Offset Voltage (1) (between pin 8 and pin 10)	$V_s = 14.4\text{V}$ $V_s = 13.2\text{V}$			150 150	mV mV
I_d	Total Quiescent Drain Current	$V_s = 14.4\text{V}$ $R_L = 4\Omega$ $V_s = 13.2\text{V}$ $R_L = 3.2\Omega$		75 70	150 160	mA mA
P_o	Output Power	$d = 10\%$ $f = 1\text{ Hz}$ $V_s = 14.4\text{V}$ $R_L = 4\Omega$ $R_L = 3.2\Omega$ $V_s = 13.2\text{V}$ $R_L = 3.2\Omega$	18 20 17	20 22 19		W
d	Distortion	$f = 1\text{ kHz}$ $V_s = 14.4\text{V}$ $R_L = 4\Omega$ $P_o = 50\text{mW to } 15\text{W}$ $V_s = 13.2\text{V}$ $R_L = 3.2\Omega$ $P_o = 50\text{mW to } 13\text{W}$			1 1	% %
V_i	Input Sensitivity	$f = 1\text{ kHz}$ $P_o = 2\text{W}$ $R_L = 4\Omega$ $P_o = 2\text{W}$ $R_L = 3.2\Omega$		9 8		mV mV
R_i	Input Resistance	$f = 1\text{ kHz}$	70			k Ω
f_L	Low Frequency Roll Off (– 3dB)	$R_L = 3.2\Omega$			40	Hz
f_H	High Frequency Roll Off (– 3dB)	$R_L = 3.2\Omega$	20			kHz
G_V	Closed Loop Voltage Gain	$f = 1\text{ kHz}$		50		dB
e_N	Total Input Noise Voltage	$R_g = 10\text{ k}\Omega$ (2)		3	10	μV
SVR	Supply Voltage Rejection	$R_g = 10\text{ k}\Omega$, $C_4 = 10\mu\text{F}$ $f_{\text{ripple}} = 100\text{ Hz}$, $V_{\text{ripple}} = 0.5\text{ V}$	45	55		dB
η	Efficiency	$V_s = 14.4\text{V}$, $f = 1\text{ kHz}$ $P_o = 20\text{W}$ $R_L = 4\Omega$ $P_o = 22\text{W}$ $R_L = 3.2\Omega$ $V_s = 13.2\text{V}$, $f = 1\text{ kHz}$ $P_o = 19\text{W}$ $R_L = 3.2\Omega$		60 60 58		% % %
T_j	Thermal Shut-down Junction Temperature	$V_s = 14.4\text{V}$, $R_L = 4\Omega$ $f = 1\text{ kHz}$, $P_{\text{tot}} = 13\text{W}$		145		$^{\circ}\text{C}$
V_{OSH}	Output Voltage with one Side of the Speaker shorted to ground	$V_s = 14.4\text{V}$ $R_L = 4\Omega$ $V_s = 13.2\text{V}$ $R_L = 3.2\Omega$			2	V

- Notes :**
1. For TDA2005M only
 2. Bandwith Filter : 22Hz to 22kHz.

Figure 3 : Output Offset Voltage versus Supply Voltage

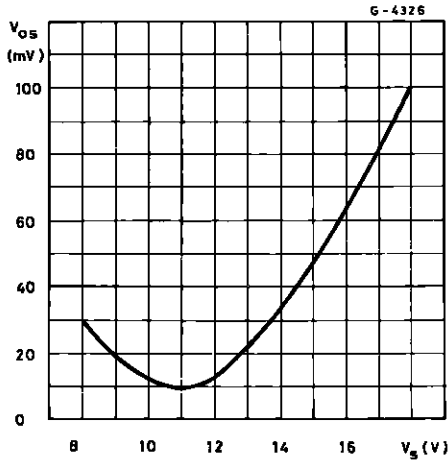

Figure 4 : Distortion versus Output Power (bridge amplifier)

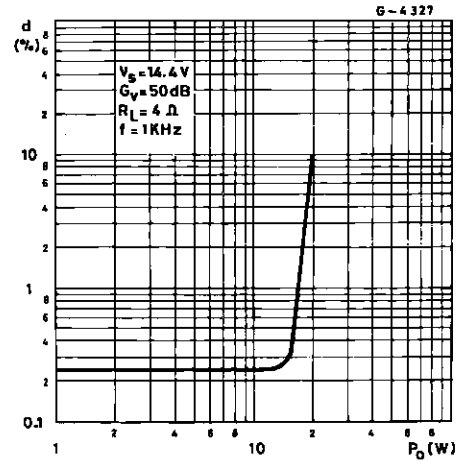
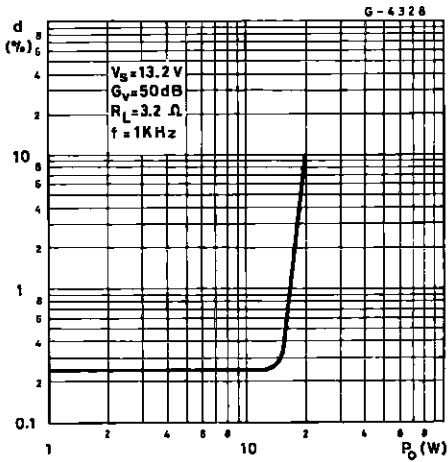

Figure 5 : Distortion versus Output Power (bridge amplifier)



BRIDGE AMPLIFIER DESIGN

The following considerations can be useful when designing a bridge amplifier.

Parameter		Single Ended	Bridge
V _{O max}	Peak Output Voltage (before clipping)	$\frac{1}{2} (V_S - 2 V_{CE \text{ sat}})$	$V_S - 2 V_{CE \text{ sat}}$
I _{O max}	Peak Output Current (before clipping)	$\frac{1}{2} \frac{V_S - 2 V_{CE \text{ sat}}}{R_L}$	$\frac{V_S - 2 V_{CE \text{ sat}}}{R_L}$
P _{O max}	RMS Output Power (before clipping)	$\frac{1}{4} \frac{(V_S - 2 V_{CE \text{ sat}})^2}{2 R_L}$	$\frac{(V_S - 2 V_{CE \text{ sat}})^2}{2 R_L}$

Where : $V_{CE \text{ sat}}$ = output transistors saturation voltage
 V_S = allowable supply voltage
 R_L = load impedance

TDA2005

Voltage and current swings are twice for a bridge amplifier in comparison with single ended amplifier. In other words, with the same R_L the bridge configuration can deliver an output power that is four times the output power of a single ended amplifier, while, with the same max output current the bridge configuration can deliver an output power that is twice the output power of a single ended amplifier. Care must be taken when selecting V_S and R_L in order to avoid an output peak current above the absolute maximum rating.

From the expression for $I_{O\max}$, assuming $V_S = 14.4V$ and $V_{CE\text{ sat}} = 2V$, the minimum load that can be driven by TDA2005 in bridge configuration is :

$$R_{L\min} = \frac{V_S - 2 V_{CE\text{ sat}}}{I_{O\max}} = \frac{14.4 - 4}{3.5} = 2.97\Omega$$

The voltage gain of the bridge configuration is given by (see Figure 34) :

$$G_V = \frac{V_0}{V_1} = 1 + \left(\frac{R_1}{R_2 \cdot R_4} \right) + \frac{R_3}{R_4}$$

For sufficiently high gains (40 to 50dB) it is possible to put $R_2 = R_4$ and $R_3 = 2 R_1$, simplifying the formula in :

$$G_V = 4 \frac{R_1}{R_2}$$

G_V (dB)	R_1 (Ω)	$R_2 = R_4$ (Ω)	R_3 (Ω)
40	1000	39	2000
50	1000	12	2000

Figure 6 : Bridge Configuration

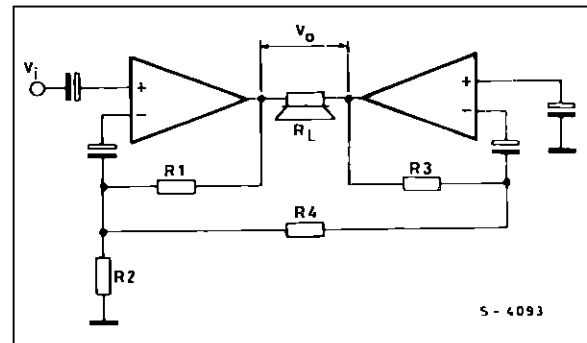

STEREO AMPLIFIER APPLICATION (TDA2005S)

Figure 7 : Typical Application Circuit

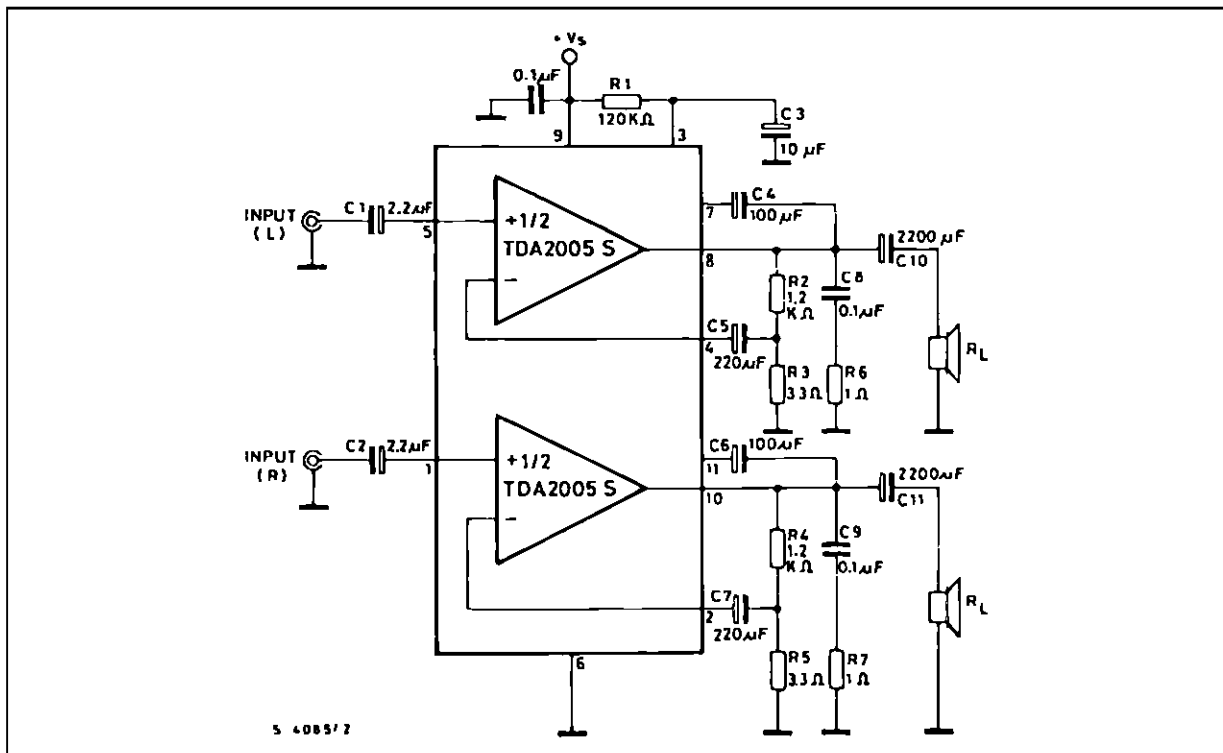

ELECTRICAL CHARACTERISTICS (refer to the **Stereo** application circuit, $T_{amb} = 25^{\circ}\text{C}$, $G_v = 50\text{dB}$, $R_{th}(\text{heatsink}) = 4^{\circ}\text{C/W}$, unless otherwise specified)

Symbol	Parameter	Test Conditions	Min.	Typ.	Max.	Unit
V_s	Supply Voltage		8		18	V
V_o	Quiescent Output Voltage	$V_s = 14.4\text{V}$ $V_s = 13.2\text{V}$	6.6 6	7.2 6.6	7.8 7.2	V V
I_d	Total Quiescent Drain Current	$V_s = 14.4\text{V}$ $V_s = 13.2\text{V}$		65 62	120 120	mA mA
P_o	Output Power (each channel)	$f = 1\text{kHz}$, $d = 10\%$ $V_s = 14.4\text{V}$ $R_L = 4\Omega$ $R_L = 3.2\Omega$ $R_L = 2\Omega$ $R_L = 1.6\Omega$ $V_s = 13.2\text{V}$ $R_L = 3.2\Omega$ $R_L = 1.6\Omega$ $V_s = 16\text{V}$ $R_L = 2\Omega$	6 7 9 10 6 9	6.5 8 10 11 6.5 12		W
d	Distortion (each channel)	$f = 1\text{kHz}$ $V_s = 14.4\text{V}$ $P_o = 50\text{mW to } 4\text{W}$ $R_L = 4\Omega$ $V_s = 14.4\text{V}$ $P_o = 50\text{mW to } 6\text{W}$ $R_L = 2\Omega$ $V_s = 13.2\text{V}$ $P_o = 50\text{mW to } 3\text{W}$ $R_L = 3.2\Omega$ $V_s = 13.2\text{V}$ $P_o = 40\text{mW to } 6\text{W}$ $R_L = 1.6\Omega$		0.2 0.3 0.2 0.3	1 1 1 1	% % % %
CT	Cross Talk (1)	$V_s = 14.4\text{V}$, $V_o = 4V_{RMS}$ $R_L = 4\Omega$, $R_g = 5k\Omega$ $f = 1\text{kHz}$ $f = 10\text{kHz}$		60 45		dB
V_i	Input Saturation Voltage		300			mV
V_i	Input Sensitivity	$f = 1\text{kHz}$, $P_o = 1\text{W}$ $R_L = 4\Omega$ $R_L = 3.2\Omega$		6 5.5		mV
R_i	Input Resistance	$f = 1\text{kHz}$	70	200		k Ω
f_L	Low Frequency Roll Off (-3dB)	$R_L = 2\Omega$			50	Hz
f_H	High Frequency Roll Off (-3dB)	$R_L = 2\Omega$	15			kHz
G_v	Voltage Gain (open loop)	$f = 1\text{kHz}$		90		dB
G_v	Voltage Gain (closed loop)	$f = 1\text{kHz}$	48	50	51	dB
ΔG_v	Closed Loop Gain Matching			0.5		dB
e_N	Total Input Noise Voltage	$R_g = 10k\Omega$ (2)		1.5	5	μV
SVR	Supply Voltage Rejection	$R_g = 10k\Omega$, $C_3 = 10\mu\text{F}$ $f_{ripple} = 100\text{Hz}$, $V_{ripple} = 0.5\text{V}$	35	45		dB
η	Efficiency	$V_s = 14.4\text{V}$, $f = 1\text{kHz}$ $P_o = 6.5\text{W}$ $P_o = 10\text{W}$ $V_s = 13.2\text{V}$, $f = 1\text{kHz}$ $P_o = 6.5\text{W}$ $P_o = 100\text{W}$ $R_L = 4\Omega$ $R_L = 2\Omega$ $R_L = 3.2\Omega$ $R_L = 1.6\Omega$		70 60 70 60		% % % %
T_j	Thermal Shut-down Junction Temperature			145		$^{\circ}\text{C}$

- Notes : 1. For TDA2005M only
2. Bandwith Filter : 22Hz to 22kHz.

Figure 8 : Quiescent Output Voltage versus Supply Voltage (Stereo amplifier)

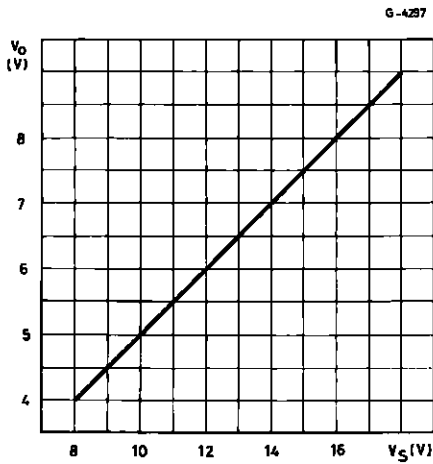

Figure 9 : Quiescent Drain Current versus Supply Voltage (Stereo amplifier)

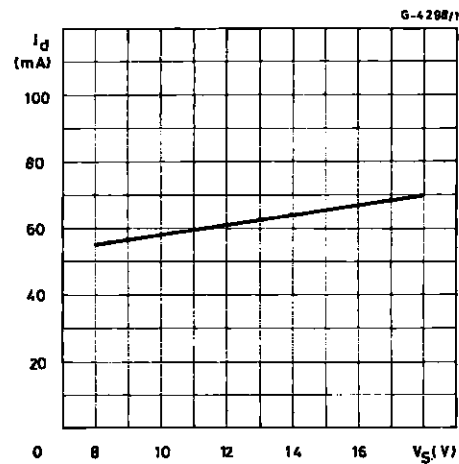

Figure 10 : Distortion versus Output Power (Stereo amplifier)

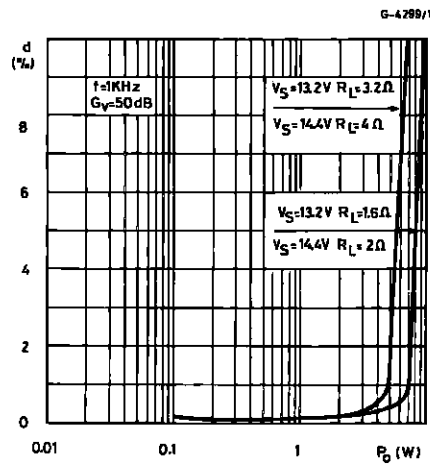

Figure 11 : Output Power versus Supply Voltage (Stereo amplifier)

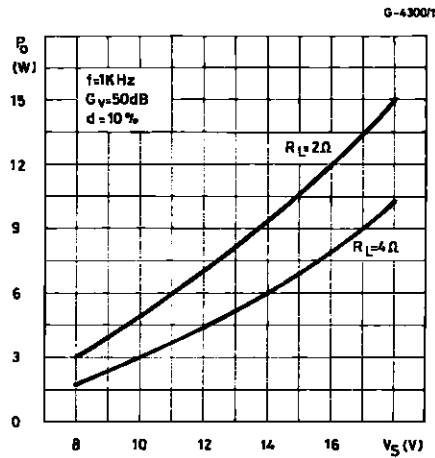

Figure 12 : Output Power versus Supply Voltage (Stereo amplifier)

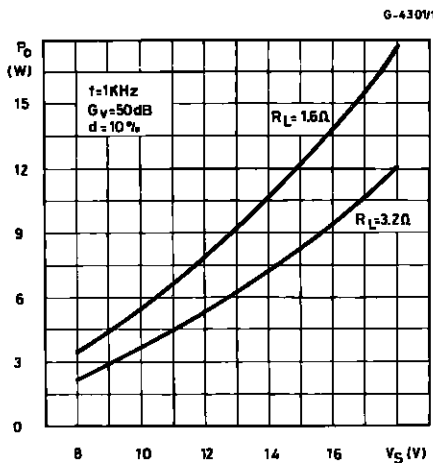

Figure 13 : Distortion versus Frequency (Stereo amplifier)

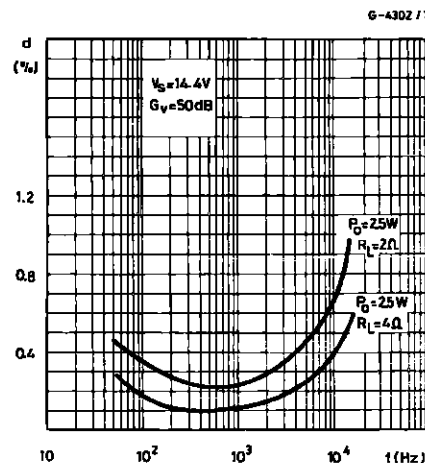

Figure 14 : Distortion versus Frequency (Stereo amplifier)

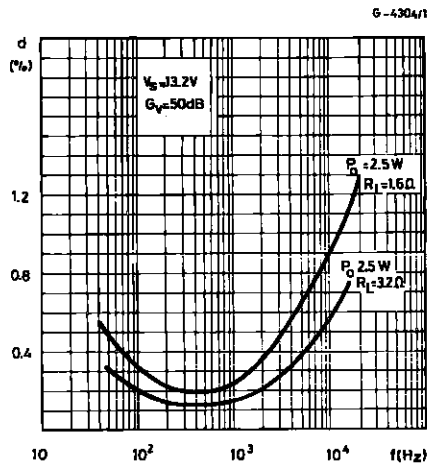

Figure 15 : Supply Voltage Rejection versus C3 (Stereo amplifier)

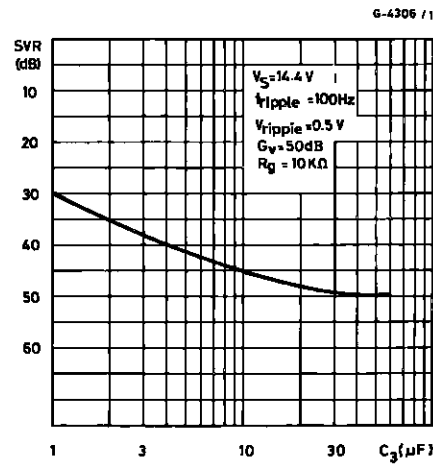

Figure 16 : Supply Voltage Rejection versus Frequency (Stereo amplifier)

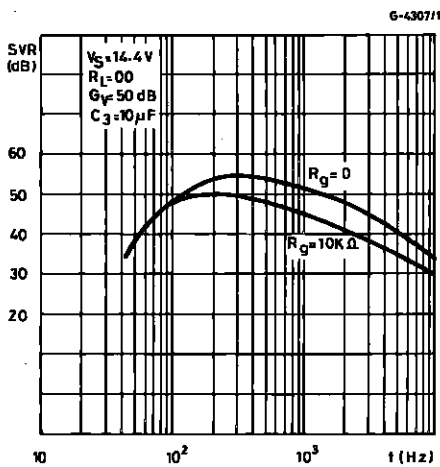

Figure 17 : Supply Voltage Rejection versus C2 and C3 (Stereo amplifier)

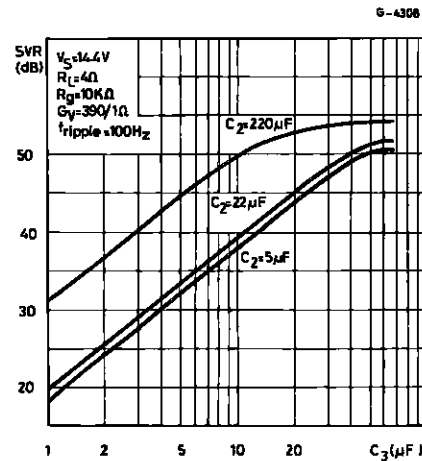

Figure 18 : Supply Voltage Rejection versus C2 and C3 (Stereo amplifier)

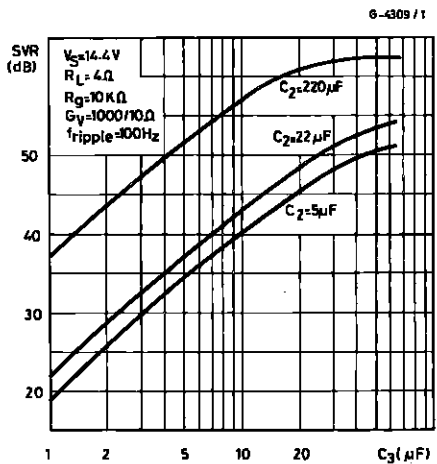

Figure 19 : Gain versus Input Sensitivity (Stereo amplifier)

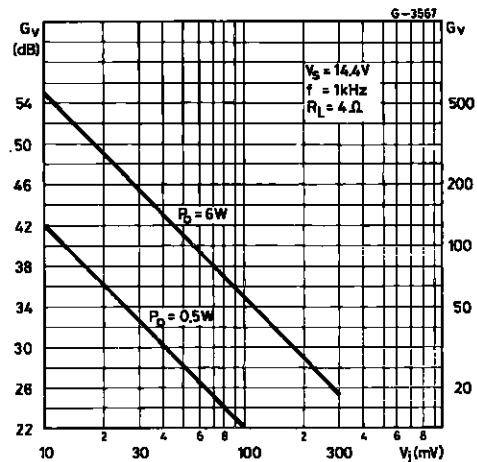

Figure 20 : Gain versus Input Sensitivity (Stereo amplifier)

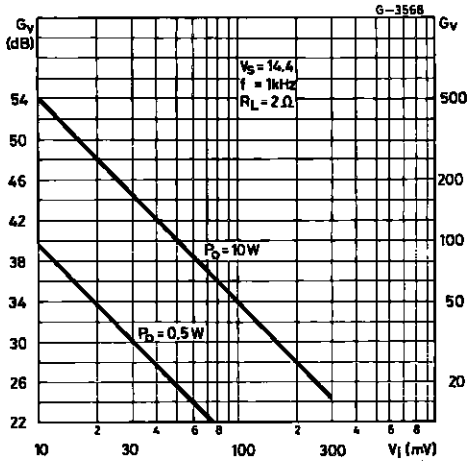

Figure 21 : Total Power Dissipation and Efficiency versus Output Power (Bridge amplifier)

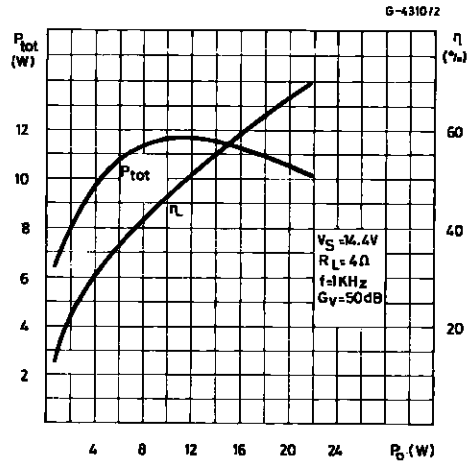
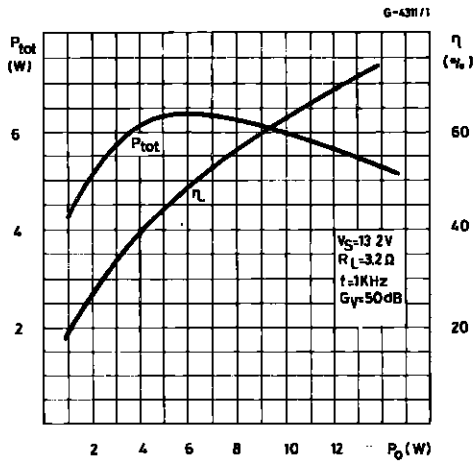

Figure 22 : Total Power Dissipation and Efficiency versus Output Power (Stereo amplifier)



APPLICATION SUGGESTION

The recommended values of the components are those shown on Bridge application circuit of Figure 1. Different values can be used ; the following table can help the designer.

Comp.	Recom. Value	Purpose	Larger Than	Smaller Than
R ₁	120 k Ω	Optimization of the Output Symmetry	Smaller P _{o max}	Smaller P _{o max}
R ₂	1k Ω			
R ₃	2 k Ω			
R _{4, R5}	12 Ω	Closed Loop Gain Setting (see Bridge Amplifier Design) (*)		
R _{6, R7}	1 Ω	Frequency Stability	Danger of Oscillation at High Frequency with Inductive Loads	
C ₁	2.2 μ F	Input DC Decoupling		
C ₂	2.2 μ F	Optimization of Turn on Pop and Turn on Delay	High Turn on Delay	Higher Turn on Pop, Higher Low Frequency Cut-off, Increase of Noise
C ₃	0.1 μ F	Supply by Pass		Danger of Oscillation
C ₄	10 μ F	Ripple Rejection	Increase of SVR, Increase of the Switch-on Time	Degradation of SVR.
C _{5, C7}	100 μ F	Bootstrapping		Increase of Distortion at low Frequency
C _{6, C8}	220 μ F	Feedback Input DC Decoupling, Low Frequency Cut-off		Higher Low Frequency Cut-off
C _{9, C10}	0.1 μ F	Frequency Stability		Danger of Oscillation

(*) The closed loop gain must be higher than 32dB.

APPLICATION INFORMATION (continued)

Figure 25 : Dual - Bridge Amplifier

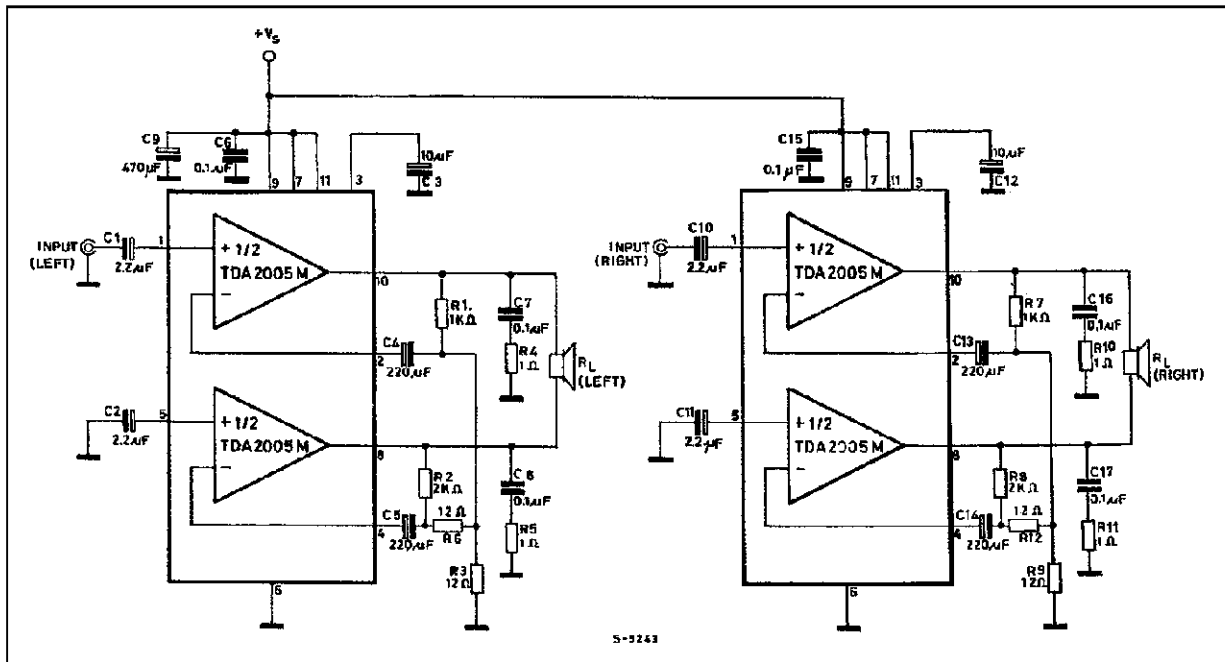
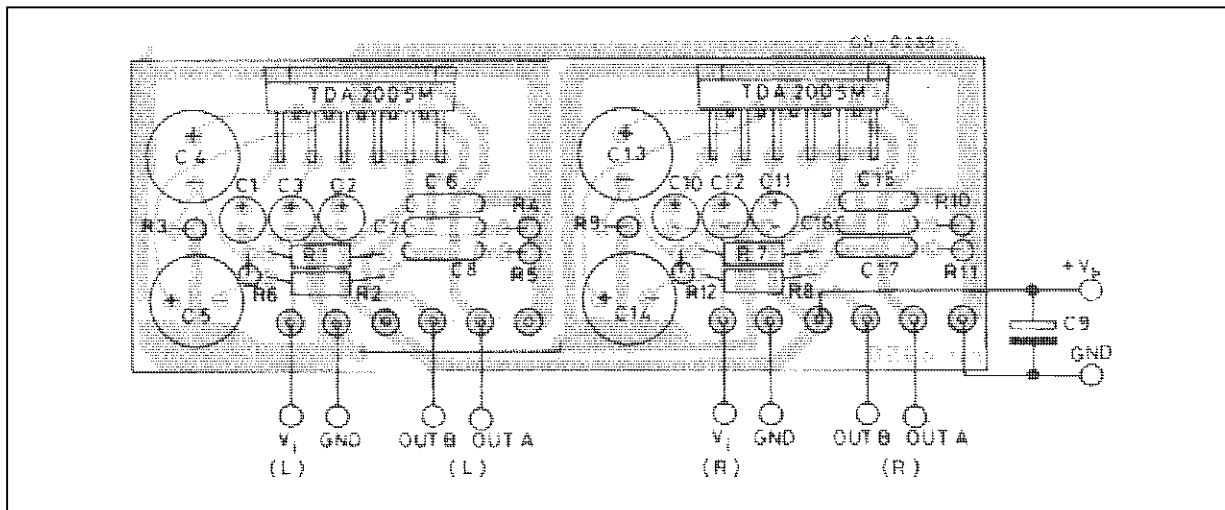

Figure 26 : P.C. Board and Components Layout of Figure 25 (1:1 scale)



TDA2005

APPLICATION INFORMATION (continued)

Figure 27 : Low Cost Bridge Amplifier ($G_v = 42\text{dB}$)

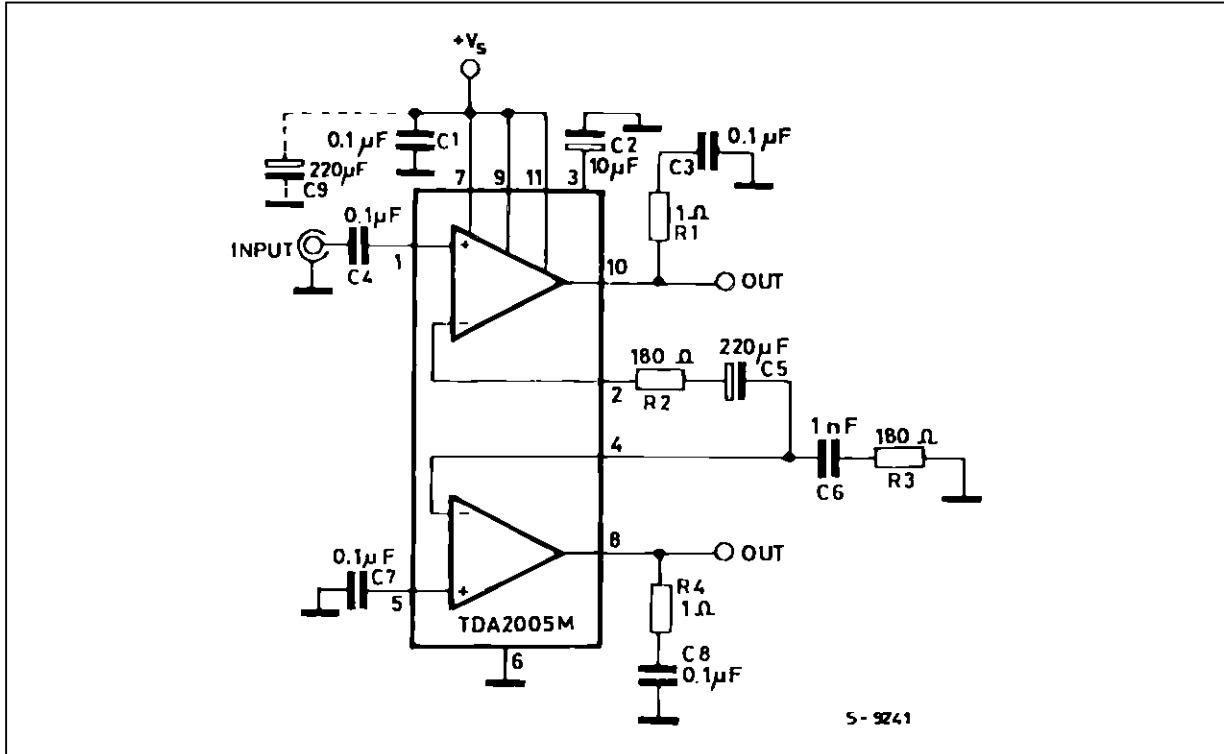
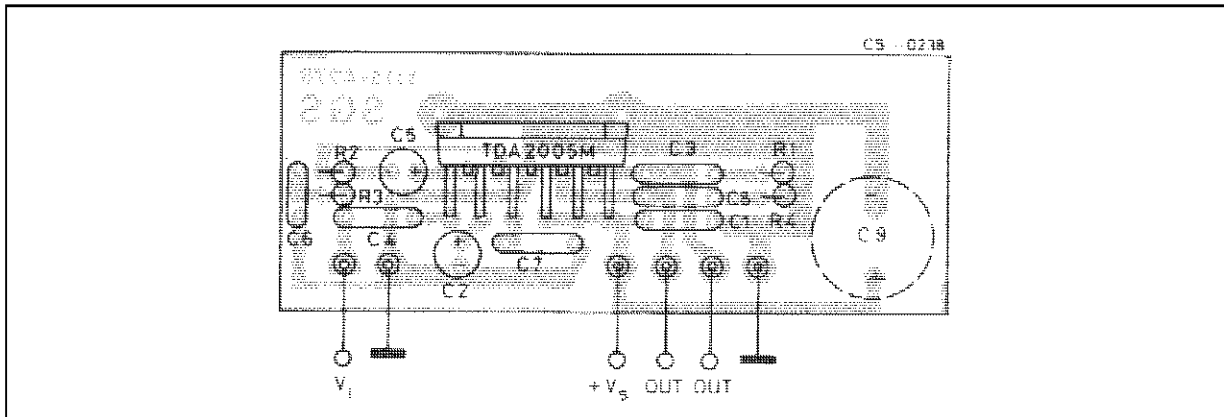

Figure 28 : P.C. Board and Components Layout of Figure 27 (1:1 scale)



APPLICATION INFORMATION (continued)

Figure 29 : 10 + 10 W Stereo Amplifier with Tone Balance and Loudness Control

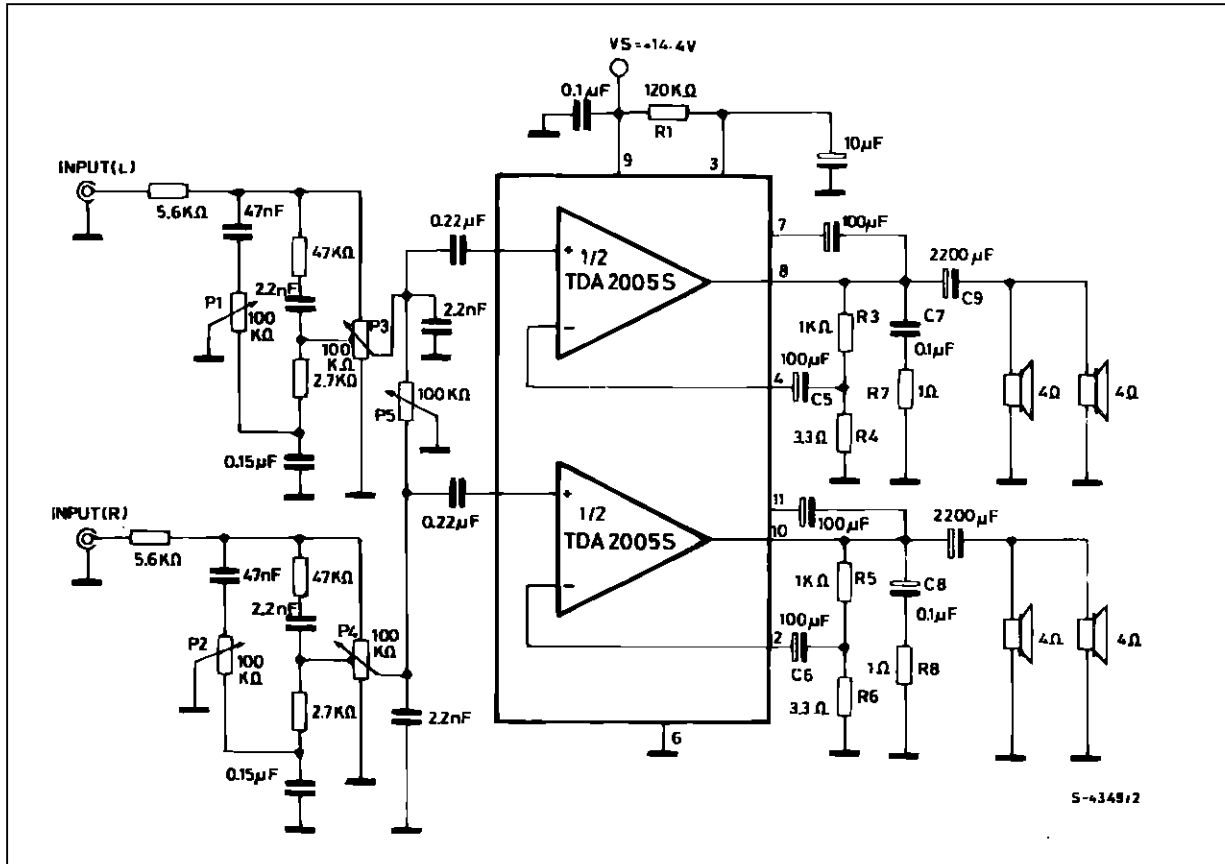
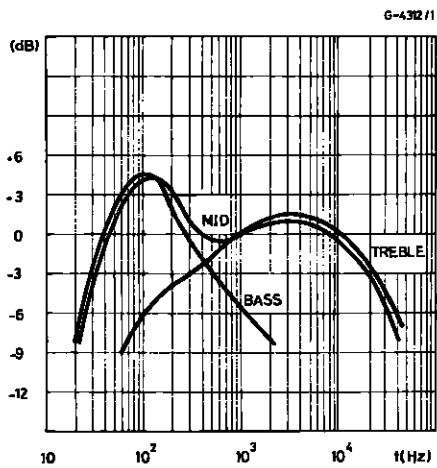

Figure 30 : Tone Control Response
(circuit of Figure 29)



APPLICATION INFORMATION (continued)

Figure 33 : Bridge Amplifier Circuit suited for Low-gain Applications ($G_V = 34\text{dB}$)

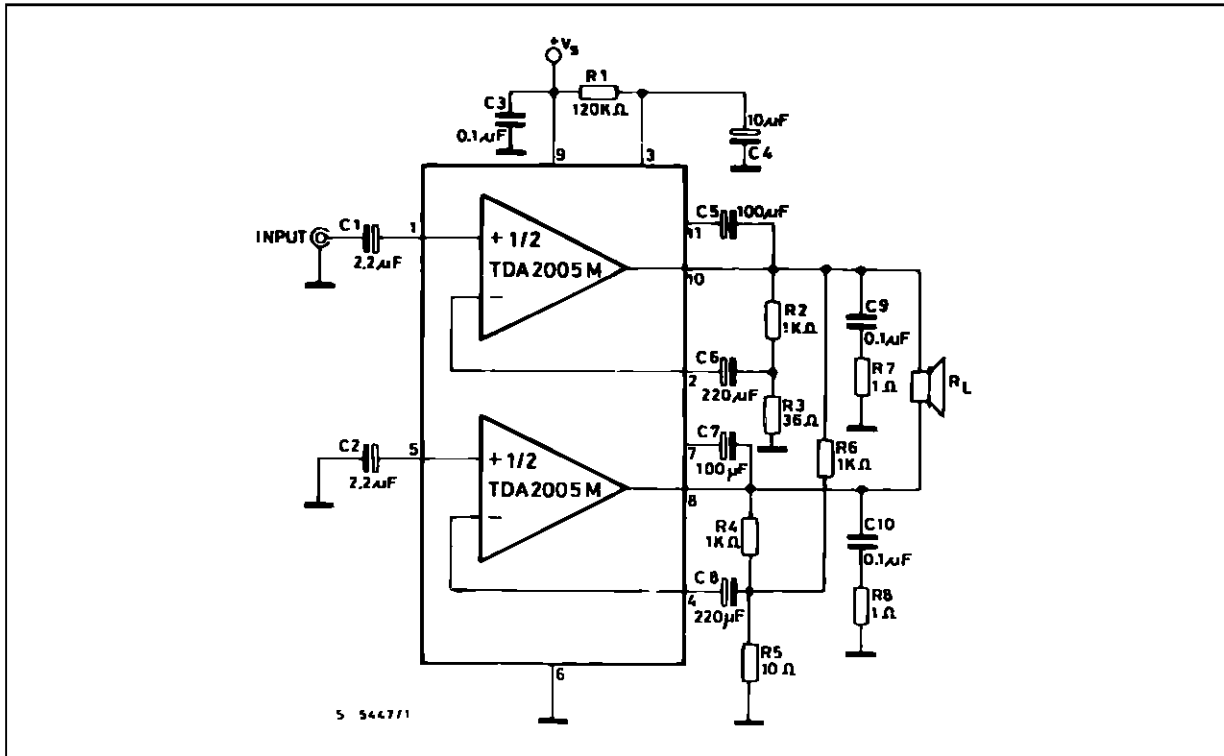
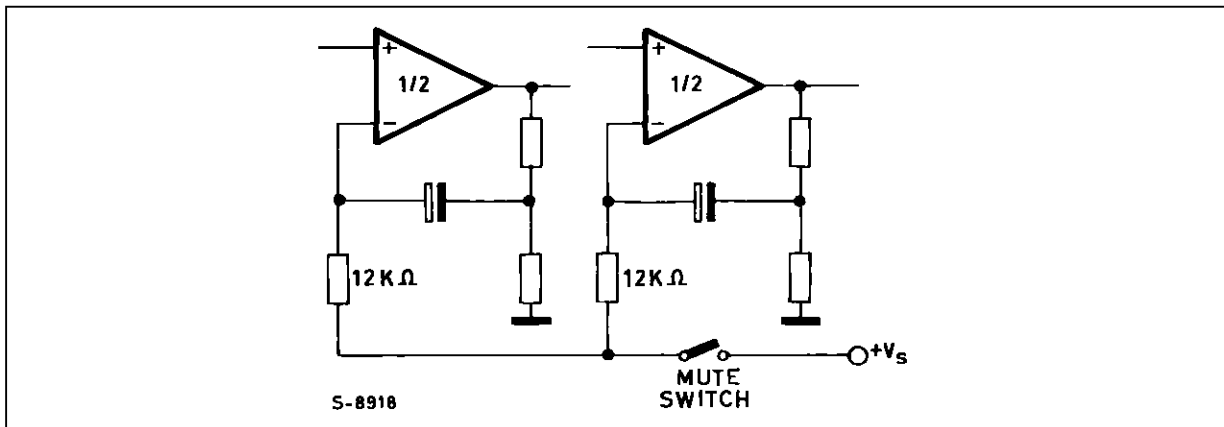

Figure 34 : Example of Muting Circuit



BUILT-IN PROTECTION SYSTEMS

Load Dump Voltage Surge

The TDA2005 has a circuit which enables it to withstand a voltage pulse train, on Pin 9, of the type shown in Figure 36.

If the supply voltage peaks to more than 40V, then an LC filter must be inserted between the supply and pin 9, in order to assure that the pulses at pin 9 will be held within the limits shown.

A suggested LC network is shown in Figure 35. With this network, a train of pulses with amplitude up to 120V and width of 2ms can be applied at point A. This type of protection is ON when the supply voltage (pulse or DC) exceeds 18V. For this reason the maximum operating supply voltage is 18V.

Figure 35

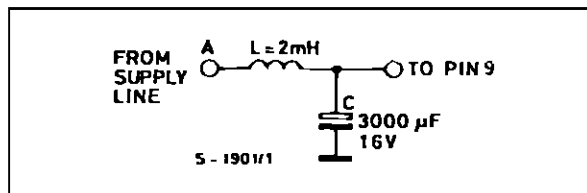
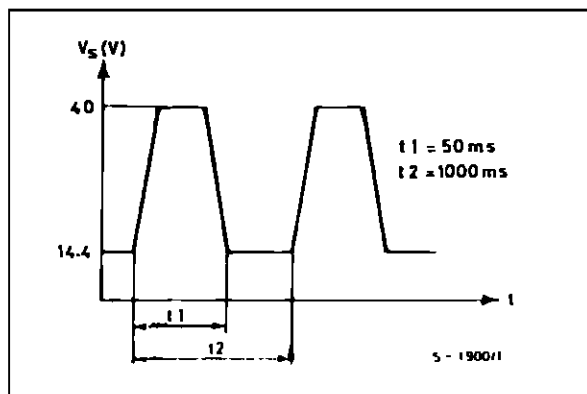

Figure 36



Short Circuit (AC and DC conditions)

The TDA2005 can withstand a permanent short-circuit on the output for a supply voltage up to 16V.

Polarity Inversion

High current (up to 10A) can be handled by the device with no damage for a longer period than the blow-out time of a quick 2A fuse (normally connected in series with the supply). This feature is added to avoid destruction, if during fitting to the car, a mistake on the connection of the supply is made.

Open Ground

When the ratio is in the ON condition and the ground is accidentally opened, a standard audio amplifier will be damaged. On the TDA2005 protection diodes are included to avoid any damage.

Inductive Load

A protection diode is provided to allow use of the TDA2005 with inductive loads.

DC Voltage

The maximum operating DC voltage for the TDA2005 is 18V.

However the device can withstand a DC voltage up to 28V with no damage. This could occur during winter if two batteries are series connected to crank the engine.

Thermal Shut-down

The presence of a thermal limiting circuit offers the following advantages :

- 1) an overload on the output (even if it is permanent), or an excessive ambient temperature can be easily withstood.
- 2) the heatsink can have a smaller factor of safety compared with that of a conventional circuit.

There is no device damage in the case of excessive junction temperature : all that happens is that P_O (and therefore P_{tot}) and I_d are reduced.

The maximum allowable power dissipation depends upon the size of the external heatsink (i.e. its thermal resistance) ; Figure 37 shows the dissippable power as a function of ambient temperature for different thermal resistance.

Loudspeaker Protection

The circuit offers loudspeaker protection during short circuit for one wire to ground.

Figure 37 : Maximum Allowable Power Dissipation versus Ambient Temperature

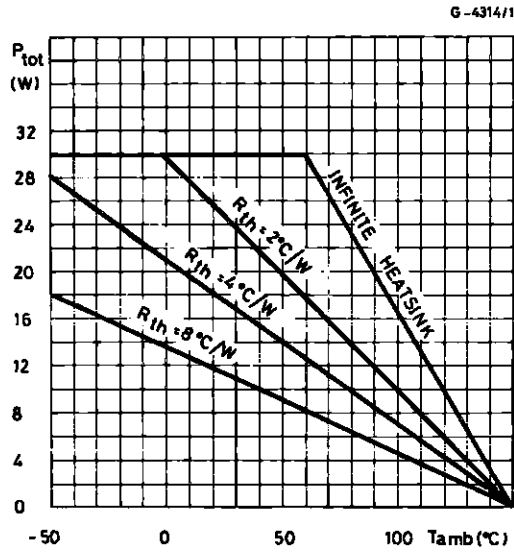

Figure 38 : Output Power and Drain Current versus Case Temperature

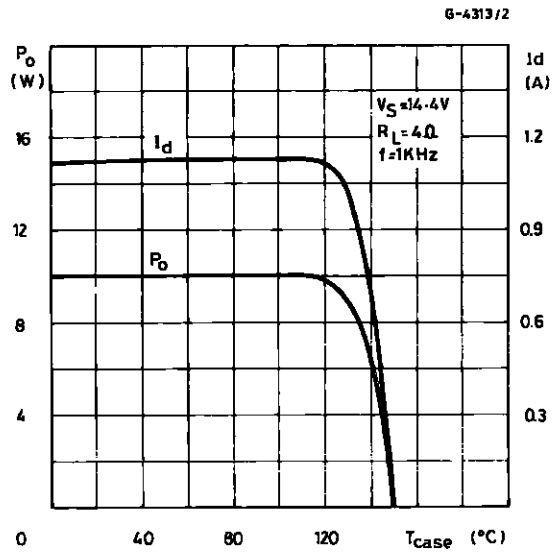
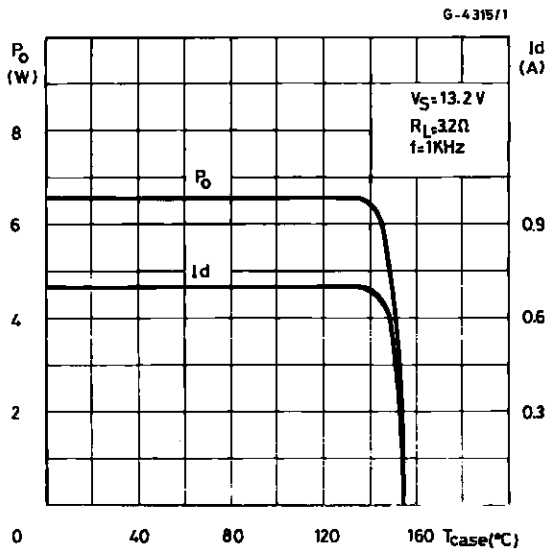
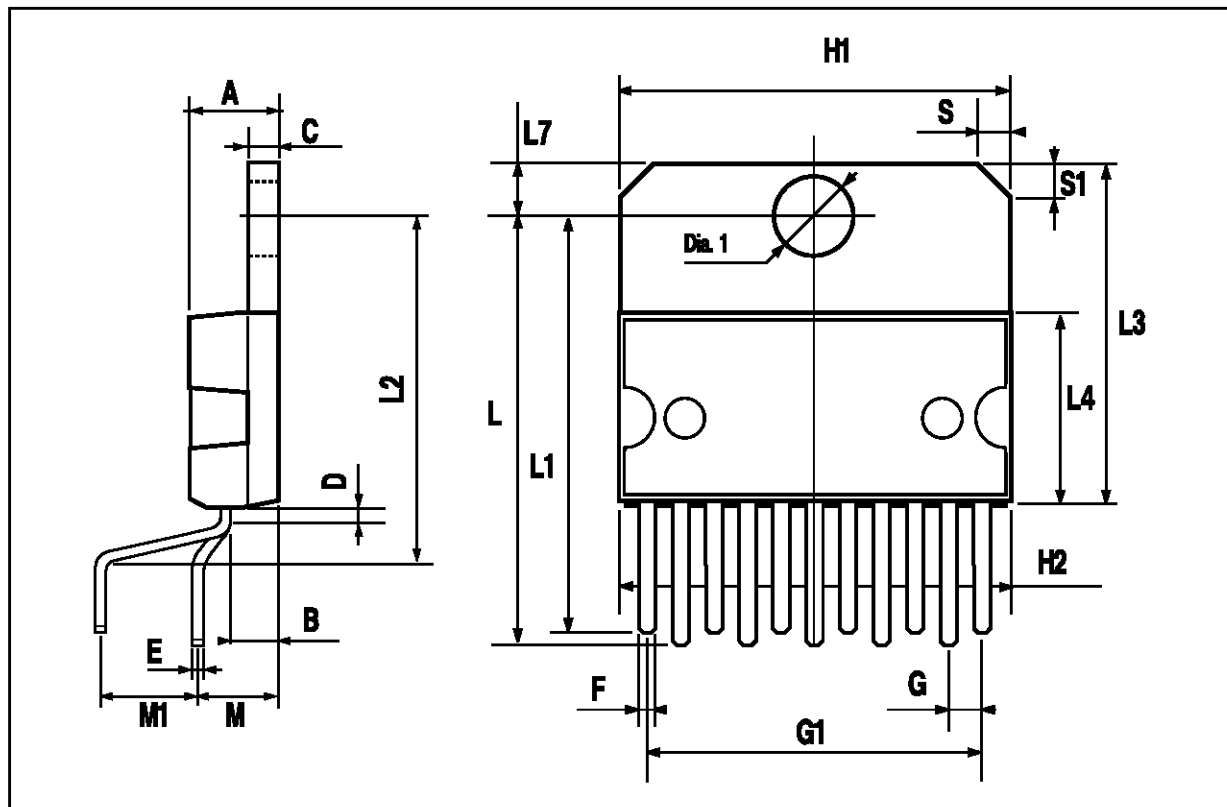

Figure 39 : Output Power and Drain Current versus Case Temperature



MULTIWATT11 PACKAGE MECHANICAL DATA

DIM.	mm			inch		
	MIN.	TYP.	MAX.	MIN.	TYP.	MAX.
A			5			0.197
B			2.65			0.104
C			1.6			0.063
D		1			0.039	
E	0.49		0.55	0.019		0.022
F	0.88		0.95	0.035		0.037
G	1.45	1.7	1.95	0.057	0.067	0.077
G1	16.75	17	17.25	0.659	0.669	0.679
H1	19.6			0.772		
H2			20.2			0.795
L	21.9	22.2	22.5	0.862	0.874	0.886
L1	21.7	22.1	22.5	0.854	0.87	0.886
L2	17.4		18.1	0.685		0.713
L3	17.25	17.5	17.75	0.679	0.689	0.699
L4	10.3	10.7	10.9	0.406	0.421	0.429
L7	2.65		2.9	0.104		0.114
M	4.25	4.55	4.85	0.167	0.179	0.191
M1	4.73	5.08	5.43	0.186	0.200	0.214
S	1.9		2.6	0.075		0.102
S1	1.9		2.6	0.075		0.102
Dia1	3.65		3.85	0.144		0.152



Information furnished is believed to be accurate and reliable. However, SGS-THOMSON Microelectronics assumes no responsibility for the consequences of use of such information nor for any infringement of patents or other rights of third parties which may result from its use. No license is granted by implication or otherwise under any patent or patent rights of SGS-THOMSON Microelectronics. Specifications mentioned in this publication are subject to change without notice. This publication supersedes and replaces all information previously supplied. SGS-THOMSON Microelectronics products are not authorized for use as critical components in life support devices or systems without express written approval of SGS-THOMSON Microelectronics.

© 1995 SGS-THOMSON Microelectronics - All Rights Reserved
MULTIWATT® is a Registered Trademark of SGS-THOMSON Microelectronics

SGS-THOMSON Microelectronics GROUP OF COMPANIES
Australia - Brazil - France - Germany - Hong Kong - Italy - Japan - Korea - Malaysia - Malta - Morocco - The Netherlands - Singapore - Spain - Sweden - Switzerland - Taiwan - Thailand - United Kingdom - U.S.A.