

20-W STEREO DIGITAL AUDIO POWER AMPLIFIER WITH EQ/DRC and FEEDBACK

FEATURES

- **Audio Input/Output**
 - 20-W Into an 8-Ω Load From an 18-V Supply
 - Wide PVCC Range (10 V to 26 V); 3.3 V Digital Supply
 - Supports One Serial Audio Input (8 kHz - 48 kHz Sample Rates) (LJ/RJ/I²S)
 - Power-Stage Feedback Allows Operation From Poorly Regulated Power Supplies
- **Audio/PWM Processing**
 - Factory-Trimmed Internal Oscillator for Automatic Rate Detection
 - High-End 32-Bit Data Path Audio Processor
 - 14 Biquads for Speaker EQ
 - Dynamic Range Control (DRC)
- **Benefits**
 - EQ: Speaker Equalization Improves Audio Performance
 - DRC: Enables Speaker Protection and Night-Mode Listening.
 - Autobank Switching: Preloaded Coefficients for Three Different Sample Rates Eliminates the Need to Update Coefficients When Sample Rate Changes
 - Autodetect: Automatically Detects Sample-Rate Changes Eliminating the Need for External Microprocessor Intervention
 - Closed-Loop Power Stage: Enables Wide PVCC Operating Range and Reduced Power Supply Ripple Distortion

DESCRIPTION

The TAS5708 is a 20-W, efficient, digital audio power amplifier for driving stereo bridge-tied speakers. A 32-bit datapath eliminates the need for pre-scaling before processing and preserves signal integrity without sacrificing dynamic range. A digital audio processor with fully programmable digital filters allows designers to custom tune speakers for optimum sound in small enclosures. A programmable DRC can adjust power levels for a scaleable design while also enabling night-mode listening modes.

The closed-loop architecture allows the device to operate from poorly regulated supplies. Figure 1 below shows the benefit of the feedback architecture when a noisy supply (1kHz, 500mVpp ripple) modulates a 10kHz audio input. The figure shows a 40dB improvement in sideband suppression when compared to an open-loop design. This correlates directly to a 24dB improvement in distortion as seen in Figure 2.

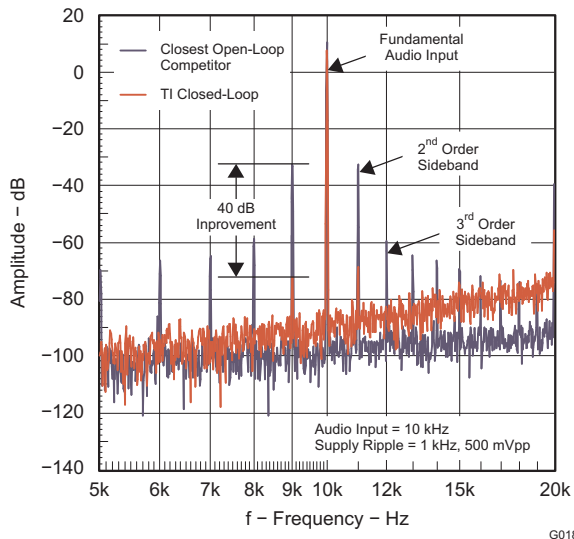

Figure 1. Supply Ripple Intermod Distortion

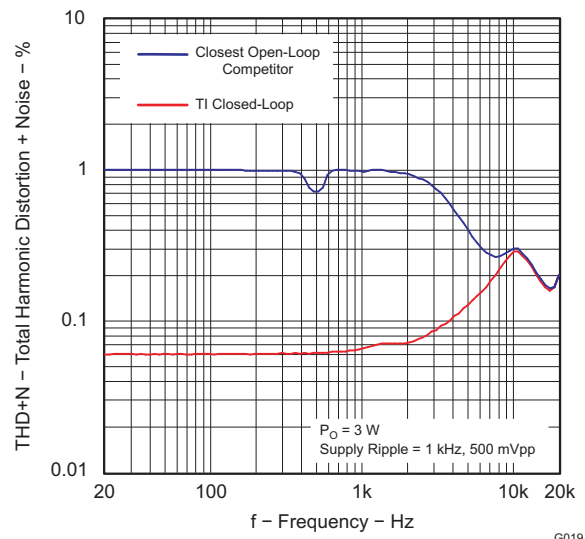

Figure 2. THD+N vs Frequency



Please be aware that an important notice concerning availability, standard warranty, and use in critical applications of Texas Instruments semiconductor products and disclaimers thereto appears at the end of this data sheet.



These devices have limited built-in ESD protection. The leads should be shorted together or the device placed in conductive foam during storage or handling to prevent electrostatic damage to the MOS gates.

SIMPLIFIED APPLICATION DIAGRAM

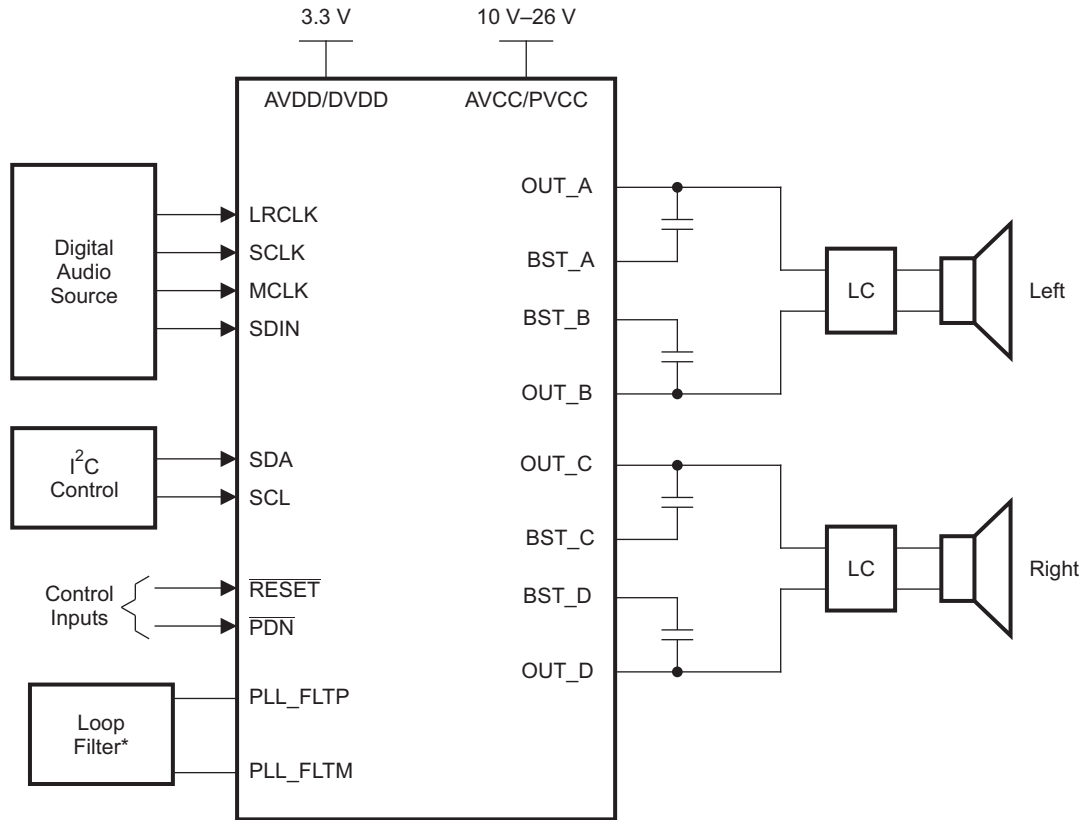

B0264-07

*Refer to user's guide for Loop Filter details.

FUNCTIONAL VIEW

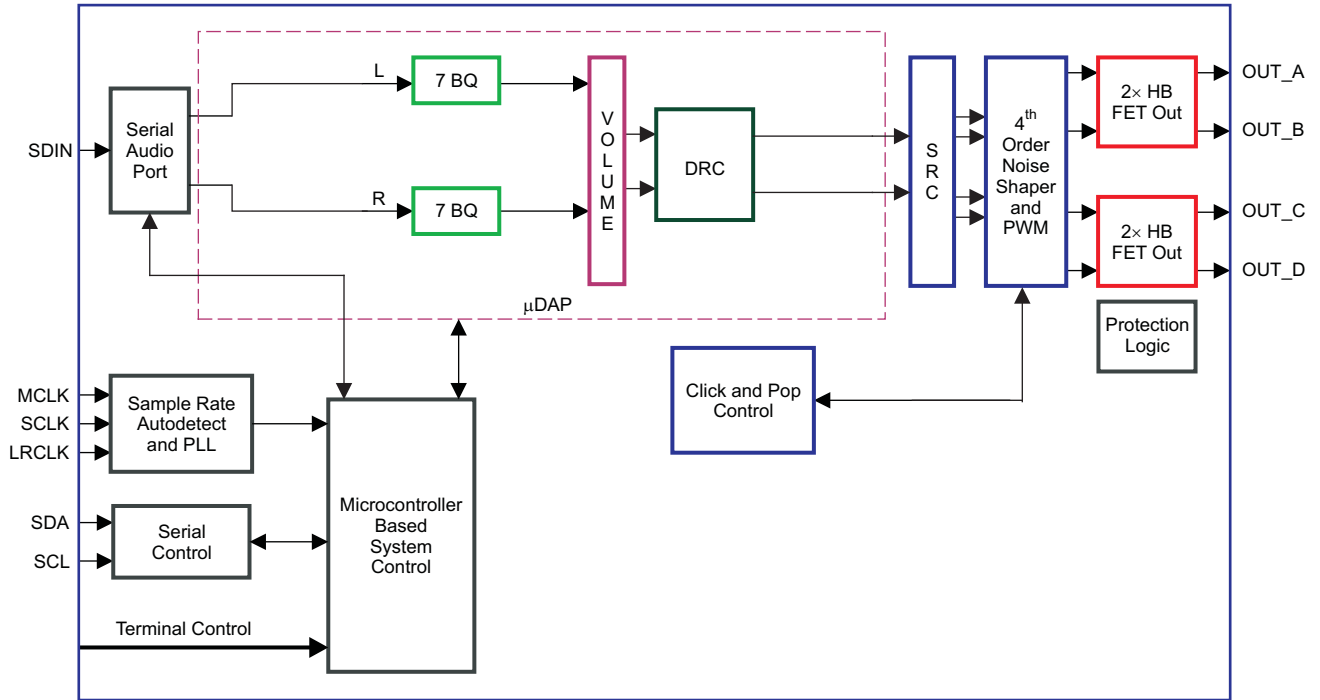

B0262-02

DAP Process Flow

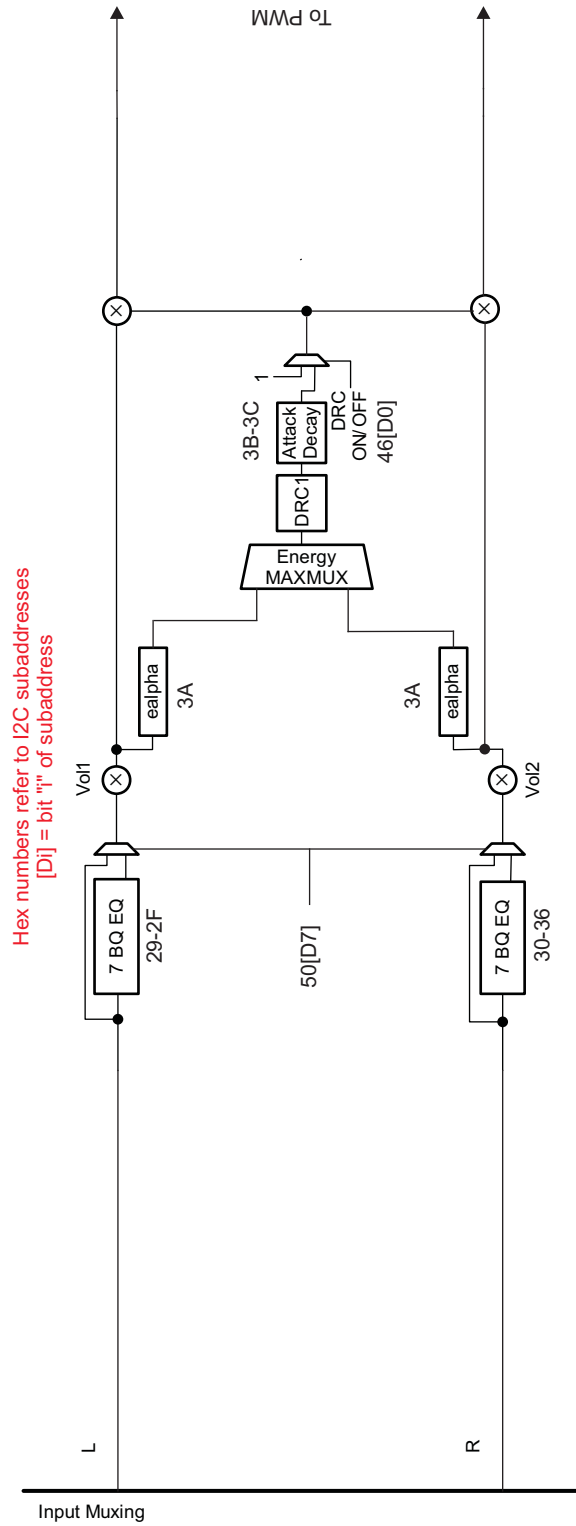

Hex numbers refer to I2C subaddresses [Dij] = bit "i" of subaddress

B0341-01

48-PIN, HTQFP PACKAGE (TOP VIEW)

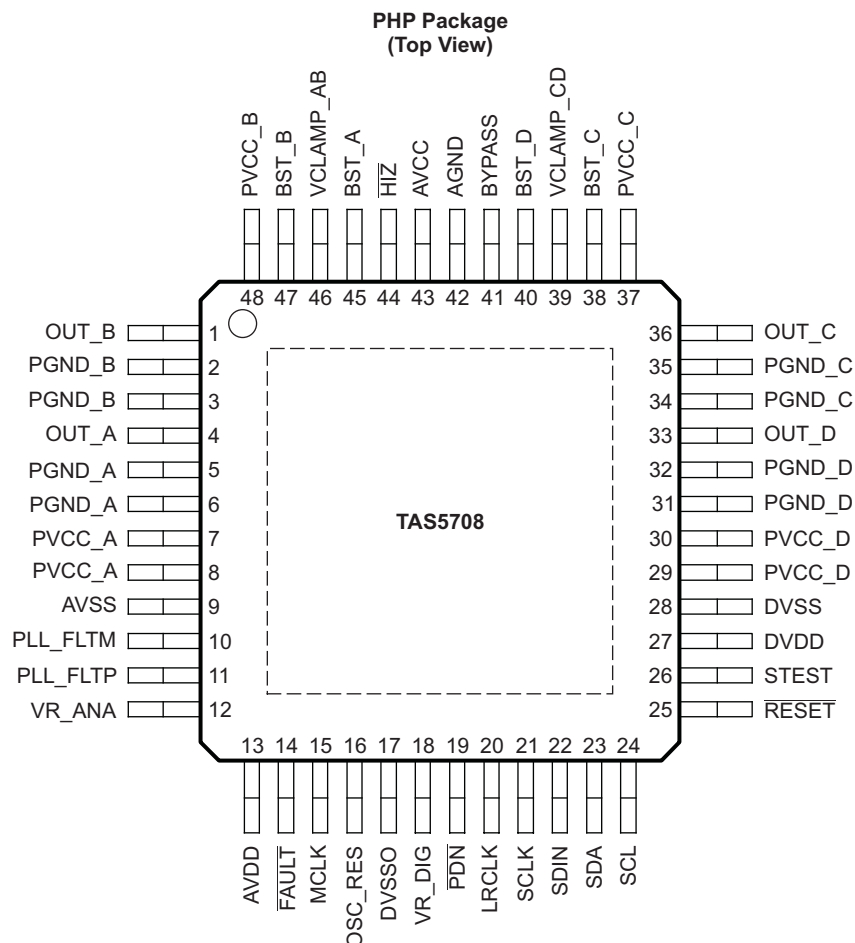

P0075-03

PIN FUNCTIONS

PIN		TYPE (1)	5-V TOLERANT	TERMINATION (2)	DESCRIPTION
NAME	NO.				
AGND	42	P			Analog ground for power stage
AVCC	43	P			Analog power supply for power stage. Connect externally to same potential as PVCC.
AVDD	13	P			3.3-V analog power supply
AVSS	9	P			Analog 3.3-V supply ground
BST_A	45	P			High-side bootstrap supply for half-bridge A
BST_B	47	P			High-side bootstrap supply for half-bridge B
BST_C	38	P			High-side bootstrap supply for half-bridge C
BST_D	40	P			High-side bootstrap supply for half-bridge D
BYPASS	41	AO			Nominally equal to $V_{CC}/8$. Internal reference voltage for analog cells
DVDD	27	P			3.3-V digital power supply
DVSS	28	P			Digital ground
DVSSO	17	P			Oscillator Ground
HIZ	44	DI		Pullup	Enable high-impedance (Hi-Z) mode (active low)

- (1) TYPE: A = analog; D = 3.3-V digital; P = power/ground/decoupling; I = input; O = output
 (2) All pullups are weak pullups and all pulldowns are weak pulldowns. The pullups and pulldowns are included to assure proper input logic levels if the pins are left unconnected (pullups → logic 1 input; pulldowns → logic 0 input).

PIN FUNCTIONS (continued)

PIN		TYPE (1)	5-V TOLERANT	TERMINATION (2)	DESCRIPTION
NAME	NO.				
LRCLK	20	DI	5-V	Pulldown	Input serial audio data left/right clock (sample rate clock)
MCLK	15	DI	5-V	Pulldown	Master Clock Input
OSC_RES	16	AO			Oscillator trim resistor. Connect an 18.2-kΩ 1% resistor to DVSSO.
OUT_A	4	O			Output, half-bridge A
OUT_B	1	O			Output, half-bridge B
OUT_C	36	O			Output, half-bridge C
OUT_D	33	O			Output, half-bridge D
$\overline{\text{PDN}}$	19	DI	5-V	Pullup	Power down, active-low. $\overline{\text{PDN}}$ prepares the device for loss of power supplies by shutting down the Noise Shaper and initiating PWM stop sequence.
PGND_A	5, 6	P			Power ground for half-bridge A
PGND_B	2, 3	P			Power ground for half-bridge B
PGND_C	34, 35	P			Power ground for half-bridge C
PGND_D	31, 32	P			Power ground for half-bridge D
PLL_FLTM	10	AO			PLL negative loop filter terminal
PLL_FLTP	11	AO			PLL positive loop filter terminal
PVCC_A	7, 8	P			Power supply input for half-bridge output A
PVCC_B	48	P			Power supply input for half-bridge output B
PVCC_C	37	P			Power supply input for half-bridge output C
PVCC_D	29, 30	P			Power supply input for half-bridge output D
$\overline{\text{RESET}}$	25	DI	5-V	Pullup	Reset, active-low. A system reset is generated by applying a logic low to this pin. $\overline{\text{RESET}}$ is an asynchronous control signal that restores the DAP to its default conditions, and places the PWM in the hard mute state (tristated).
SCL	24	DI	5-V		I ² C serial control clock input
SCLK	21	DI	5-V	Pulldown	Serial audio data clock (shift clock). SCLK is the serial audio port input data bit clock.
SDA	23	DIO	5-V		I ² C serial control data interface input/output
SDIN	22	DI	5-V	Pulldown	Serial audio data input. SDIN supports three discrete (stereo) data formats.
STEST	26	DI			Factory test pin. Connect directly to DVSS.
$\overline{\text{FAULT}}$	14	DO			Backend error indicator. Asserted LOW for over current errors. De-asserted upon recovery from error condition.
VR_ANA	12	P			Internally regulated 1.8-V analog supply voltage. This pin must not be used to power external devices.
VR_DIG	18	P			Internally regulated 1.8-V digital supply voltage. This pin must not be used to power external devices.
VCLAMP_AB	46	AO			Internally generated voltage supply for channel A and B gate drive. This pin must not be used to power external devices. Connect only to external decoupling capacitor
VCLAMP_CD	39	AO			Internally generated voltage supply for channel C and D gate drive. This pin must not be used to power external devices. Connect only to external decoupling capacitor

ABSOLUTE MAXIMUM RATINGS

 over operating free-air temperature range (unless otherwise noted) ⁽¹⁾⁽²⁾

		VALUE	UNIT
Supply voltage	DVDD, AVDD	–0.3 to 3.6	V
	PVCC_X, AVCC	–0.3 to 30	V
Input voltage	3.3-V digital inputs (except $\overline{\text{HIZ}}$)	–0.5 to DVDD + 0.5	V
	3.3-V $\overline{\text{HIZ}}$ input	–0.3 to AVDD + 0.3	V
	5-V tolerant ⁽³⁾ digital inputs (except MCLK)	–0.5 to DVDD + 2.5 ⁽²⁾	V
	5-V tolerant MCLK input	–0.5 to AVDD + 2.5 ⁽²⁾	V
OUT_x to PGND_X		32 ⁽⁴⁾	V
BST_x to PGND_X		43 ⁽⁴⁾	V
Operating free-air temperature		0 to 85	°C
Operating junction temperature range		0 to 150	°C
Storage temperature range, T _{stg}		–40 to 125	°C

- (1) Stresses beyond those listed under *absolute ratings* may cause permanent damage to the device. These are stress ratings only and functional operation of the device at these or any other conditions beyond those indicated under *recommended operation conditions* are not implied. Exposure to absolute-maximum conditions for extended periods may affect device reliability.
- (2) Maximum pin voltage should not exceed 6.0V
- (3) 5-V tolerant inputs are $\overline{\text{PDN}}$, $\overline{\text{RESET}}$, SCLK, LRCLK, MCLK, SDIN, SDA, and SCL.
- (4) DC voltage + peak ac waveform measured at the pin should be below the allowed limit for all conditions.

DISSIPATION RATINGS⁽¹⁾

PACKAGE	DERATING FACTOR ABOVE T _A = 25°C	T _A ≤ 25°C POWER RATING	T _A = 45°C POWER RATING	T _A = 70°C POWER RATING
7-mm x 7-mm HTQFP	40 mW/°C	5 W	4.2 W	3.2 W

- (1) This data was taken using 1 oz trace and copper pad that is soldered directly to a JEDEC standard high-k PCB. The thermal pad must be soldered to a thermal land on the printed-circuit board. See TI Technical Briefs SLMA002 for more information about using the HTQFP thermal pad

RECOMMENDED OPERATING CONDITIONS

			MIN	NOM	MAX	UNIT
	Digital/analog supply voltage	DVDD, AVDD	3	3.3	3.6	V
	Half-bridge supply voltage	PVCC_X, AVCC	10		26	V
V _{IH}	High-level input voltage	Digital Inputs	2			V
V _{IL}	Low-level input voltage	Digital Inputs			0.8	V
T _A	Operating ambient temperature range		0		85	°C
T _J ⁽¹⁾	Operating junction temperature range		0		125	°C
R _L (BTL)	Load impedance	Output filter: L = 33 μH, C = 1 μF.	6	8		Ω
R _L (PBTL)	Load impedance	Output filter: L = 33 μH, C = 1 μF.	3.2	4		Ω
L _O (BTL)	Output-filter inductance	Minimum output inductance under short-circuit condition	10			μH
L _O (PBTL)	Output-filter inductance	Minimum output inductance under short-circuit condition	10			μH

- (1) Continuous operation above the recommended junction temperature may result in reduced reliability and/or lifetime of the device.

PWM OPERATION AT RECOMMENDED OPERATING CONDITIONS

PARAMETER	TEST CONDITIONS	VALUE	UNIT
Output sample rate	11.025/22.05/44.1-kHz data rate ±2%	352.8	kHz
	48/24/12/8/16/32-kHz data rate ±2%	384	

PLL INPUT PARAMETERS AND EXTERNAL FILTER COMPONENTS

PARAMETER		TEST CONDITIONS	MIN	TYP	MAX	UNIT
f_{MCLKI}	MCLK Frequency		2.8224		24.576	MHz
	MCLK duty cycle		40%	50%	60%	
t_r / t_f (MCLK)	Rise/fall time for MCLK				5	ns
	LRCLK allowable drift before LRCLK reset				4	MCLKs
	External PLL filter capacitor C1	SMD 0603 Y5V		47		nF
	External PLL filter capacitor C2	SMD 0603 Y5V		4.7		nF
	External PLL filter resistor R	SMD 0603, metal film		470		Ω

ELECTRICAL CHARACTERISTICS

DC Characteristics, BD BTL Mode, $F_S = 48$ kHz, $T_A = 25^\circ\text{C}$, $PVCC_X = AVCC = 18$ V, $DVDD=AVDD= 3.3$ V, $R_L = 8$ Ω (unless otherwise noted)

PARAMETER		TEST CONDITIONS	MIN	TYP	MAX	UNIT
V_{OH}	High-level output voltage	$\overline{\text{FAULT}}$ and SDA $I_{OH} = -4$ mA , $DVDD=AVDD=3.0$ V	2.4			V
V_{OL}	Low-level output voltage	$\overline{\text{FAULT}}$ and SDA $I_{OL} = 4$ mA , $DVDD=AVDD=3.0$ V			0.5	V
$ VOS $	Class-D output offset voltage			26		mV
V_{BYPASS}	PVCC/8 reference for analog section	No load	2.1	2.26	2.4	V
I_{IL}	Low-level input current	Digital Inputs $V_I \leq V_{IL}$ $DVDD = AVDD = 3.6$ V			75	μA
I_{IH}	High-level input current	Digital Inputs $V_I \geq V_{IH}$ $DVDD = AVDD = 3.6$ V			75	μA
I_{DD}	3.3-V supply current	3.3V Supply voltage ($DVDD + AVDD$)		43	77	mA
		Normal mode Reset ($\overline{\text{RESET}} = \text{low}$, $\overline{\text{PDN}} = \text{high}$)		19	24	
I_{CC}	Half-Bridge supply current	No Load ($PVCC + AVCC$)		34	60	mA
		Normal Mode Reset ($\overline{\text{RESET}} = \text{low}$, $\overline{\text{PDN}} = \text{high}$)		54	310	
$r_{DS(on)}^{(1)}$	Drain-to-source resistance, high-side	$V_{CC} = 18$ V , $I_O = 500$ mA, $T_J = 25^\circ\text{C}$, includes metallization resistance		240		m Ω
	Drain-to-source resistance, low-side			240		
Protection						
V_{UVP}	Undervoltage protection limit	$PVCC_X = AVCC$ falling		8.4		V
$V_{UVP,hyst}$	Undervoltage protection limit	$PVCC_X = AVCC$ rising		8.5		V
V_{OVP}	Over-voltage protection limit	$PVCC_X = AVCC$ rising		27.5		V
$V_{OVP,hyst}$	Over-voltage protection limit	$PVCC_X = AVCC$ falling		27.2		V
$OTE^{(2)}$	Over temperature error (output shutdown, unlatched)			150		$^\circ\text{C}$
$OTE_{HYST}^{(2)}$	Extra temperature drop required to recover from error			15		$^\circ\text{C}$

(1) This does not include bond-wire or pin resistance.

(2) Specified by design

AC Characteristics, PVCC_x = AVCC = 18V, BTL BD Mode, FS=48KHz, T_A = 25°C, AVDD = DVDD = 3.3 V, R_L = 8 Ω, C_{BST} = 220 nF, Audio Frequency = 1 kHz, AES17 filter (unless otherwise noted). All performance is in accordance with recommended operating conditions, unless otherwise specified.

PARAMETER		TEST CONDITIONS	MIN	TYP	MAX	UNIT
K _{SVR}	Supply ripple rejection	200-mVpp ripple at 1 kHz, no audio input		-80		dB
P _O	Continuous output power	THD+N = 10%, f = 1 kHz		20.2		W
		THD+N = 7%, f = 1 kHz		18.8		W
THD+N	Total harmonic distortion + noise	f = 1 kHz, P _O = 1 W		0.03%		
V _n	Output integrated noise (rms)	A-weighted		105		μV
Crosstalk		P _O = 1 W, f = 1 kHz		-63		dB
SNR	Signal-to-noise ratio ⁽¹⁾	Maximum Power at THD+N < 1%, f = 1 kHz, A-weighted		100		dB

(1) SNR is calculated relative to 0-dBFS Input Level

AC Characteristics, PVCC_x = AVCC = 12V, BTL BD Mode, FS=48KHz, T_A = 25°C, AVDD = DVDD = 3.3 V, R_L = 8 Ω, C_{BST} = 220 nF, Audio Frequency = 1 kHz, AES17 filter (unless otherwise noted). All performance is in accordance with recommended operating conditions, unless otherwise specified.

PARAMETER		TEST CONDITIONS	MIN	TYP	MAX	UNIT
K _{SVR}	Supply ripple rejection	200-mVpp ripple at 1 kHz, no audio input		-80		dB
P _O	Continuous output power	THD+N = 10%, f = 1 kHz		8.8		W
		THD+N = 7%, f = 1 kHz		8.4		W
THD+N	Total harmonic distortion + noise	f = 1 kHz, P _O = 1 W		0.04%		
V _n	Output integrated noise (rms)	A-weighted		106		μV
Crosstalk		f = 1 kHz, P _O = 1 W		-63		dB
SNR	Signal-to-noise ratio ⁽¹⁾	Maximum Power at THD+N < 1%, f = 1 kHz, A-weighted		97		dB

(1) SNR is calculated relative to 0-dBFS Input Level

SERIAL AUDIO PORTS SLAVE MODE

over recommended operating conditions (unless otherwise noted)

PARAMETER		TEST CONDITIONS	MIN	TYP	MAX	UNIT
f_{SCLKIN}	Frequency, SCLK $32 \times f_S$, $48 \times f_S$, $64 \times f_S$	$C_L = 30 \text{ pF}$	1.024		12.288	MHz
t_{su1}	Setup time, LRCLK to SCLK rising edge		10			ns
t_{h1}	Hold time, LRCLK from SCLK rising edge		10			ns
t_{su2}	Setup time, SDIN to SCLK rising edge		10			ns
t_{h2}	Hold time, SDIN from SCLK rising edge		10			ns
	LRCLK frequency		8	48	48	kHz
	SCLK duty cycle		40%	50%	60%	
	LRCLK duty cycle		40%	50%	60%	
	SCLK rising edges between LRCLK rising edges		32		64	SCLK edges
$t_{(edge)}$	LRCLK clock edge with respect to the falling edge of SCLK		-1/4		1/4	SCLK period
$t_r / t_f(SCLK/LRCLK)$	Rise/fall time for SCLK/LRCLK				8	ns

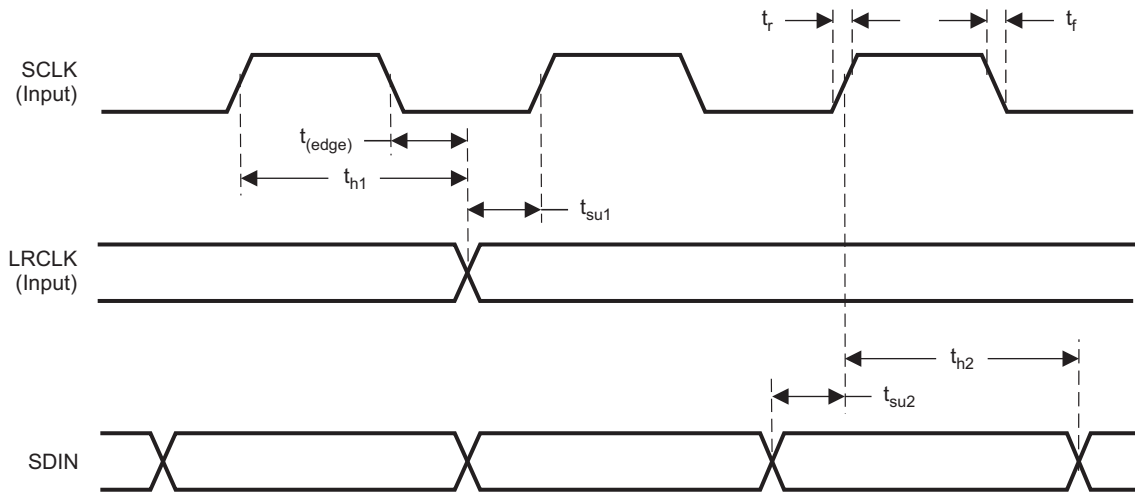

T0026-04

Figure 3. Slave Mode Serial Data Interface Timing

I²C SERIAL CONTROL PORT OPERATION

Timing characteristics for I²C Interface signals over recommended operating conditions (unless otherwise noted)

PARAMETER		TEST CONDITIONS	MIN	MAX	UNIT
f _{SCL}	Frequency, SCL	No wait states		400	kHz
t _{w(H)}	Pulse duration, SCL high		0.6		μs
t _{w(L)}	Pulse duration, SCL low		1.3		μs
t _r	Rise time, SCL and SDA			300	ns
t _f	Fall time, SCL and SDA			300	ns
t _{su1}	Setup time, SDA to SCL		100		ns
t _{h1}	Hold time, SCL to SDA		0		ns
t _(buf)	Bus free time between stop and start condition		1.3		μs
t _{su2}	Setup time, SCL to start condition		0.6		μs
t _{h2}	Hold time, start condition to SCL		0.6		μs
t _{su3}	Setup time, SCL to stop condition		0.6		μs
C _L	Load capacitance for each bus line			400	pF

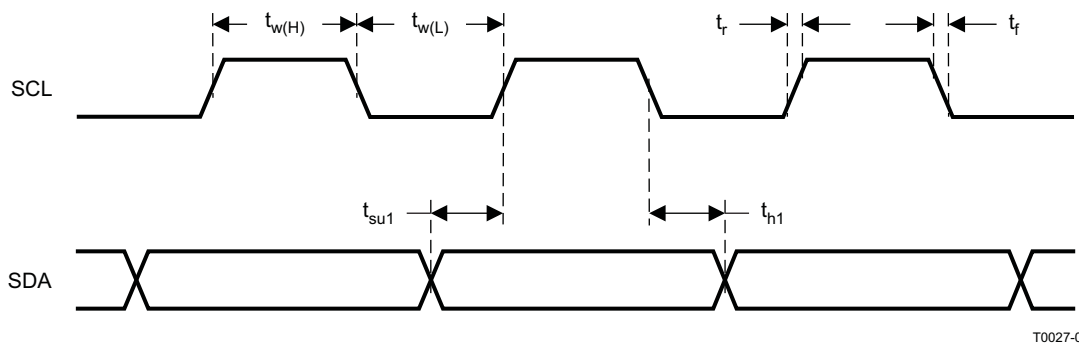

Figure 4. SCL and SDA Timing

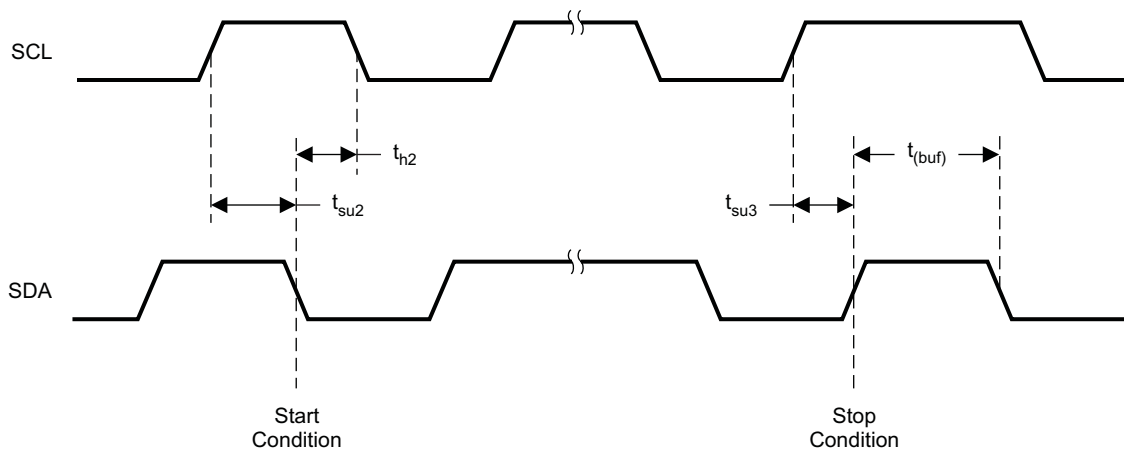
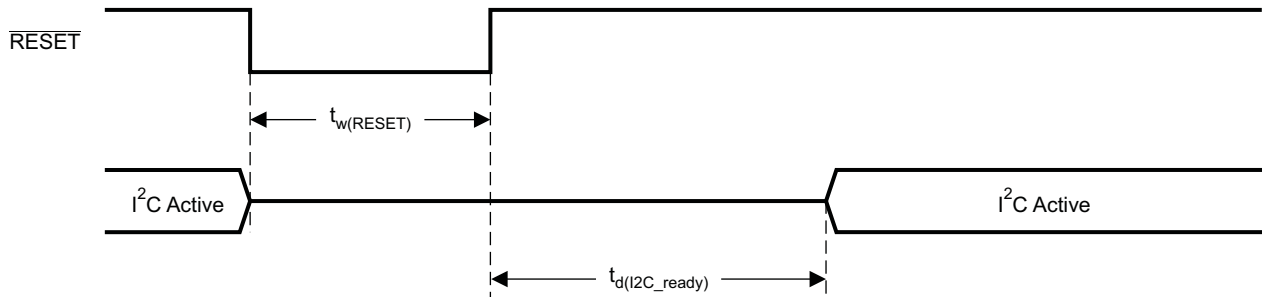

Figure 5. Start and Stop Conditions Timing

RESET TIMING ($\overline{\text{RESET}}$)

Control signal parameters over recommended operating conditions (unless otherwise noted). Please refer to Recommended Use Model section on usage of all terminals.

PARAMETER		MIN	TYP	MAX	UNIT
$t_{w(\text{RESET})}$	Pulse duration, $\overline{\text{RESET}}$ active	100			us
$t_{d(\text{I2C_ready})}$	Time to enable I ² C			13.5	ms



System Initialization.
Enable via I²C.

T0421-01

NOTE: On power up, it is recommended that the TAS5708 $\overline{\text{RESET}}$ be held LOW for at least 100 μs after DVDD has reached 3.0 V

NOTE: If the $\overline{\text{RESET}}$ is asserted LOW while $\overline{\text{PDN}}$ is LOW, then the $\overline{\text{RESET}}$ must continue to be held LOW for at least 100 μs after $\overline{\text{PDN}}$ is deasserted (HIGH).

Figure 6. Reset Timing

TYPICAL CHARACTERISTICS, BTL CONFIGURATION

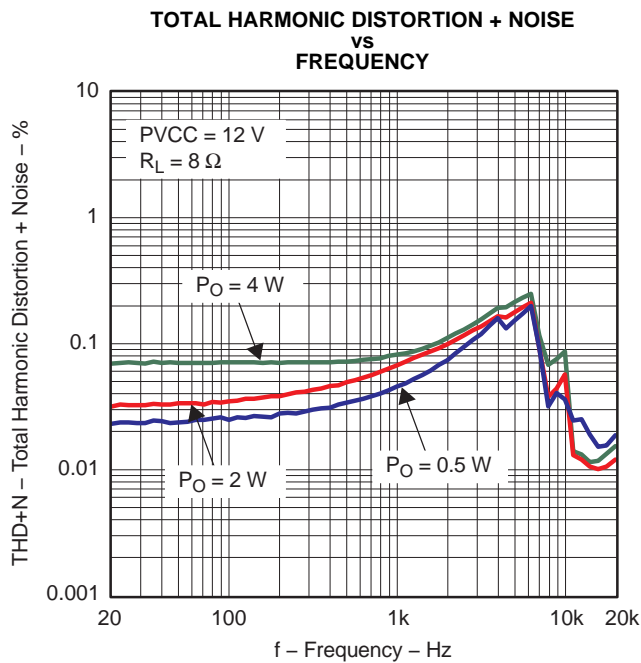

Figure 7.

G001

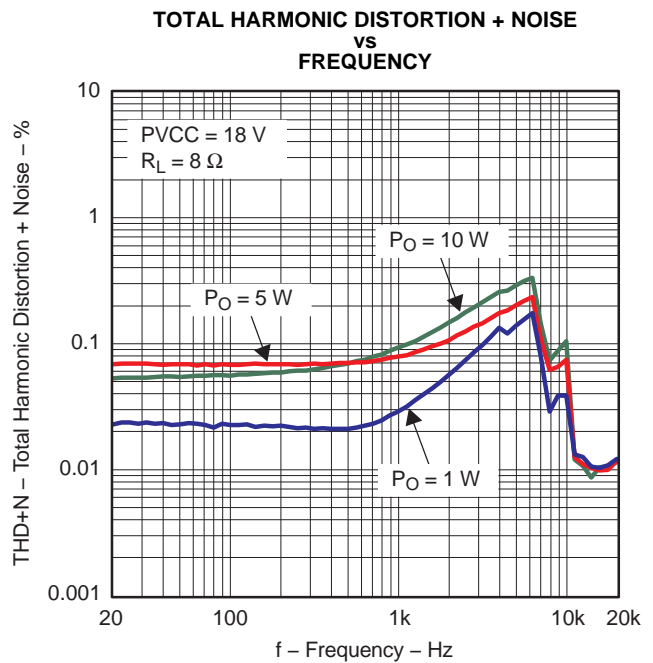

Figure 8.

G002

TYPICAL CHARACTERISTICS, BTL CONFIGURATION (continued)

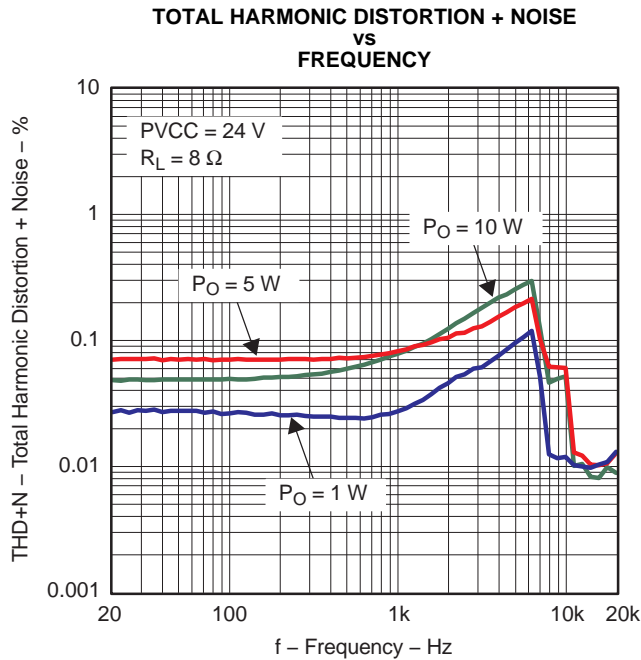

Figure 9.

G003

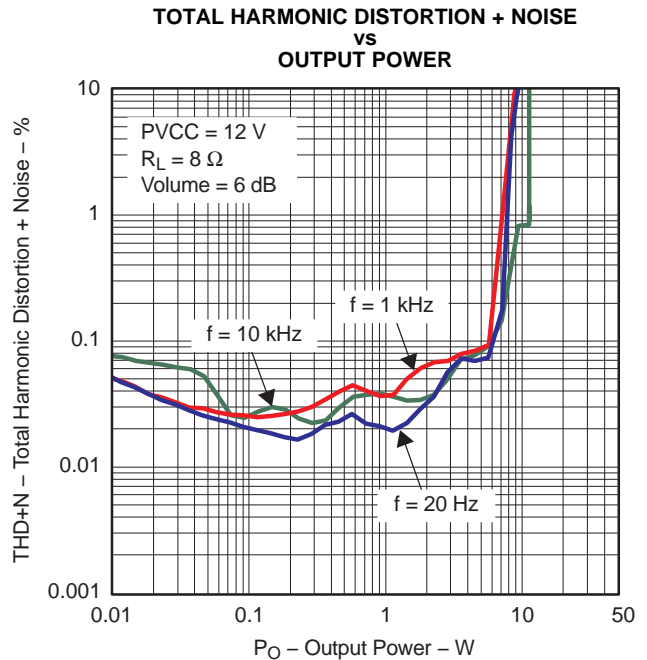

Figure 10.

G004

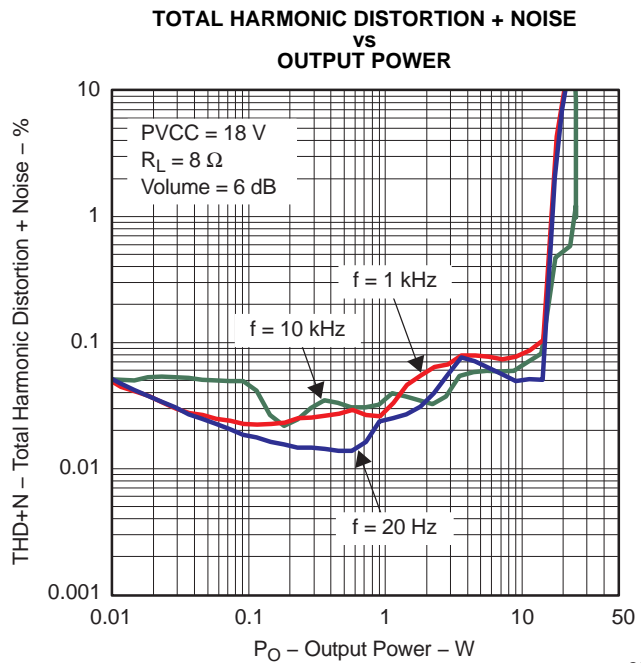

Figure 11.

G005

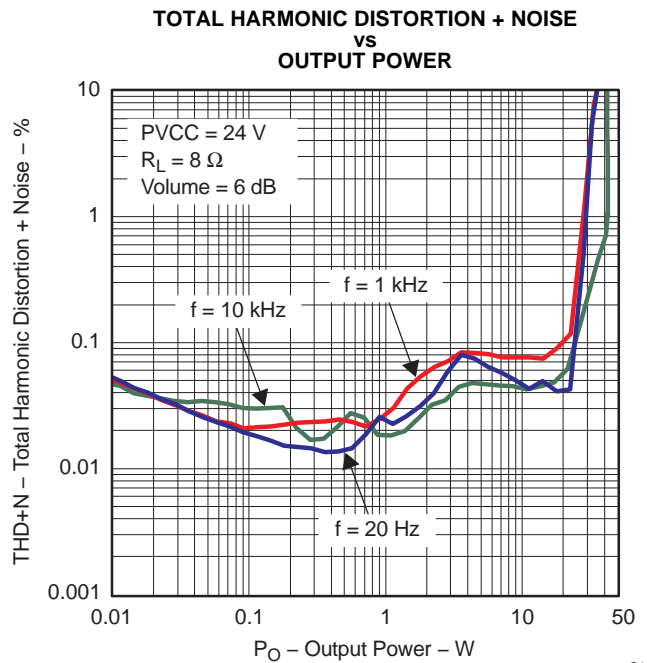

Figure 12.

G006

TYPICAL CHARACTERISTICS, BTL CONFIGURATION (continued)

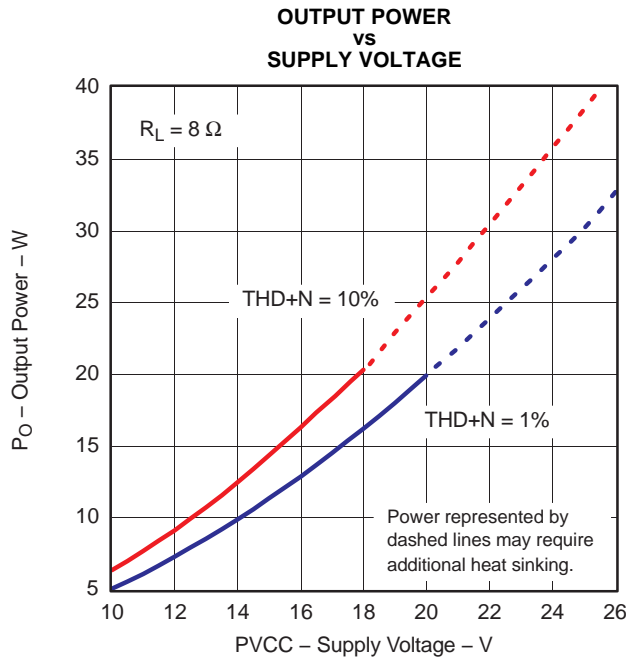

Figure 13.

G008

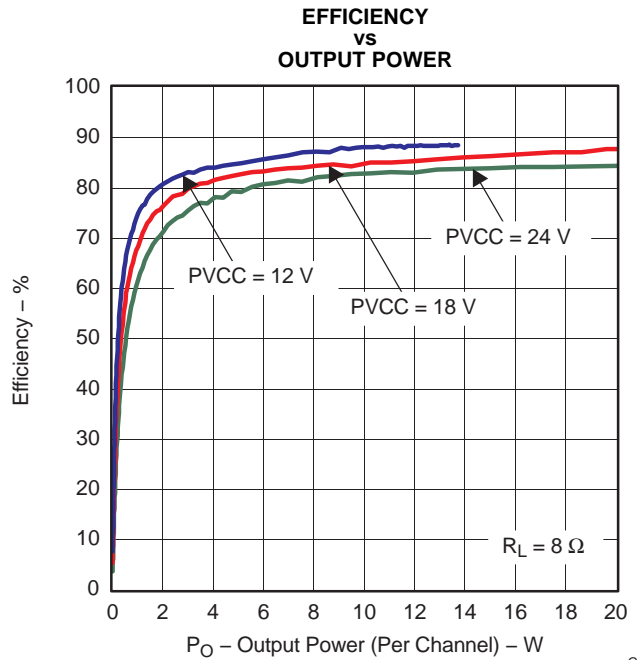

Figure 14.

G010

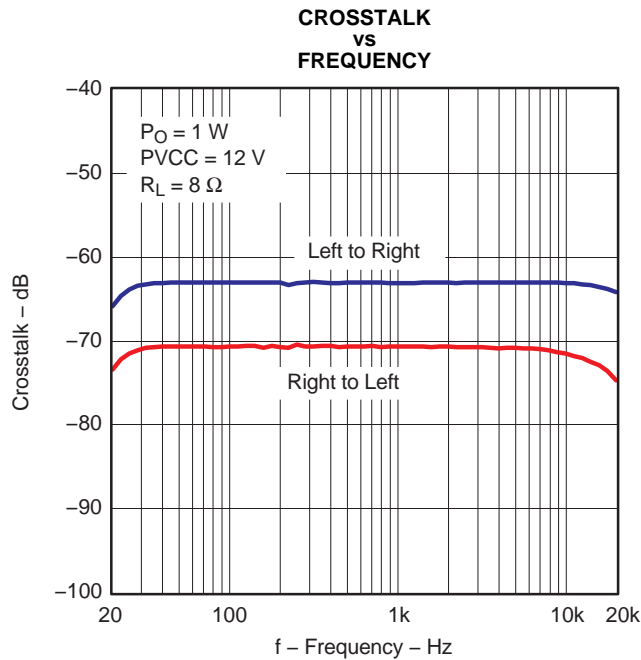

Figure 15.

G013

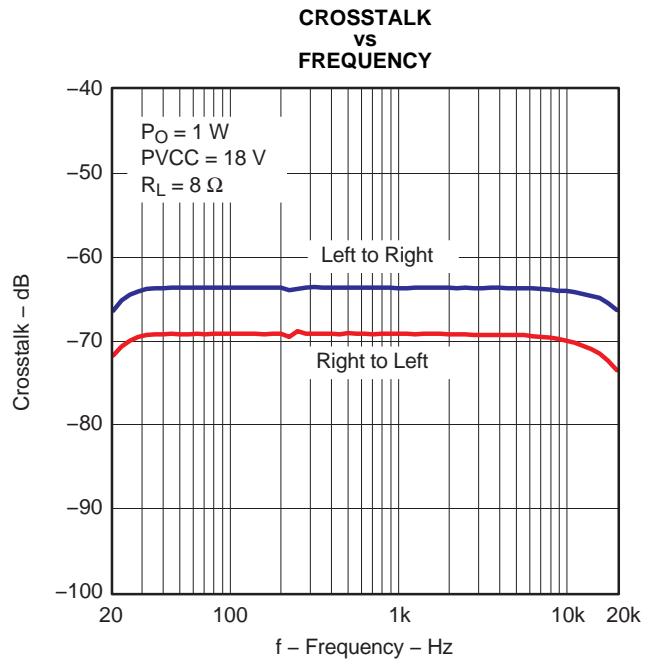

Figure 16.

G014

TYPICAL CHARACTERISTICS, BTL CONFIGURATION (continued)

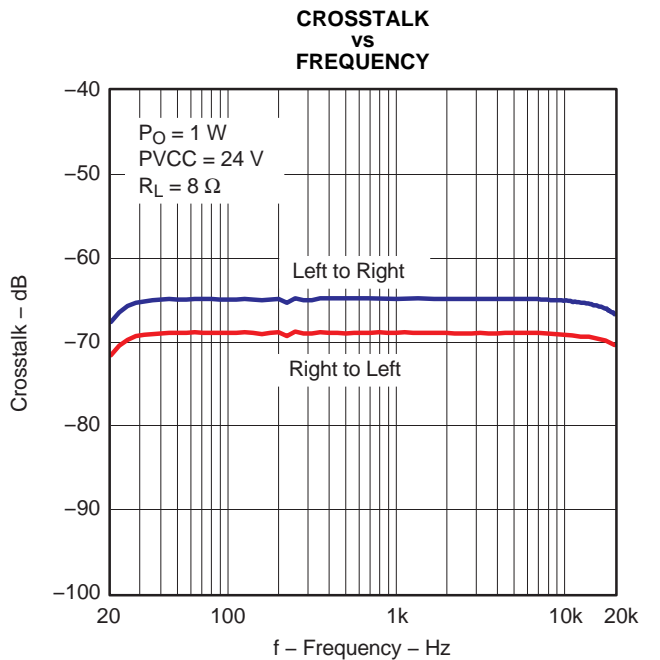

Figure 17.

DETAILED DESCRIPTION

POWER SUPPLY

To facilitate system design, the TAS5708 needs only a 3.3-V supply in addition to the 10-V to 26-V power-stage supply. An internal voltage regulator provides suitable voltage levels for the gate drive circuitry. Additionally, all circuitry requiring a floating voltage supply, e.g., the high-side gate drive, is accommodated by built-in bootstrap circuitry requiring only a few external capacitors.

In order to provide good electrical and acoustical characteristics, the PWM signal path for the output stage is designed as identical, independent half-bridges. For this reason, each half-bridge has separate bootstrap pins (BST_X), and power-stage supply pins (PVCC_X). The gate drive voltages (VCLAMP_AB and VCLAMP_CD) are derived from the PVCC voltage. Special attention should be paid to placing all decoupling capacitors as close to their associated pins as possible. In general, inductance between the power-supply pins and decoupling capacitors must be avoided.

For a properly functioning bootstrap circuit, a small ceramic capacitor must be connected from each bootstrap pin (BST_X) to the power-stage output pin (OUT_X). When the power-stage output is low, the bootstrap capacitor is charged through an internal diode connected between the gate-drive regulator output pin (VCLAMP_X) and the bootstrap pin. When the power-stage output is high, the bootstrap capacitor potential is shifted above the output potential and thus provides a suitable voltage supply for the high-side gate driver. In an application with PWM switching frequencies in the range from 352 kHz to 384 kHz, it is recommended to use 220-nF ceramic capacitors, size 0603 or 0805, for the bootstrap supply. These 220-nF capacitors ensure sufficient energy storage, even during minimal PWM duty cycles, to keep the high-side power stage FET (LDMOS) fully turned on during the remaining part of the PWM cycle.

Special attention should be paid to the power-stage power supply; this includes component selection, PCB placement, and routing. As indicated, each half-bridge has independent power-stage supply pins (PVCC_X). For optimal electrical performance, EMI compliance, and system reliability, it is important that each PVCC_X pin is decoupled with a 100-nF ceramic capacitor placed as close as possible to each supply pin.

The TAS5708 is fully protected against erroneous power-stage turnon due to parasitic gate charging.

ERROR REPORTING

Any fault resulting in device shutdown is signaled by the $\overline{\text{FAULT}}$ pin going low (see [Table 1](#)). A sticky version of this pin is available on D1 of register 0X02.

Table 1. $\overline{\text{FAULT}}$ Output States

$\overline{\text{FAULT}}$	DESCRIPTION
0	Overcurrent (OC) ERROR
1	No faults (normal operation)

DEVICE PROTECTION SYSTEM

Overcurrent (OC) Protection

The device has independent, fast-reacting current detectors on all high-side and low-side power-stage FETs, which protects against shorts across the load, to GND, or to PVCC. The protection system triggers a latching shutdown, resulting in the power stage being set in the high-impedance (Hi-Z) state and $\overline{\text{FAULT}}$ being asserted low. The device returns to normal operation once the fault condition (i.e., a short circuit on the output) is removed. Current limiting and overcurrent protection are not independent for half-bridges. That is, if the bridge-tied load between half-bridges A and B causes an overcurrent fault, half-bridges A, B, C, and D are shut down.

Overtemperature Protection

The TAS5708 has an over-temperature protection system. If the device junction temperature exceeds 150°C (nominal), the device is put into thermal shutdown, resulting in all half-bridge outputs being set in the high-impedance (Hi-Z) state. The TAS5708 recovers automatically once the temperature drops approximately 15°.

Undervoltage Protection (UVP) and Overvoltage Protection (OVP)

THE UVP circuits of the TAS5708 fully protect the device in any power-up/down and brownout situation. The UVP engages if PVCC_X = AVCC drops below 8.4-V (typical) and disengages when PVCC_X = AVCC exceeds 8.5-V. The OVP circuits protect against voltage spikes and engage when PVCC_X = AVCC exceeds 27.5-V (typical). The OVP circuits disengage when PVCC_X = AVCC drops below 27.2-V. When the protection circuits engage, all half-bridge outputs are immediately placed in the high-impedance (Hi-Z) state.

SERIAL DATA INTERFACE

Serial data is input on SDIN. The PWM outputs are derived from SDIN. The TAS5708 DAP accepts serial data in 16-, 20-, or 24-bit left-justified, right-justified, and I²S serial data formats.

CLOCK, AUTO DETECTION, and PLL

The TAS5708 is a slave device. It accepts MCLK, SCLK, and LRCLK. The digital audio processor (DAP) supports all the sample rates and MCLK rates that are defined in the [clock control register](#).

The TAS5708 checks to verify that SCLK is a specific value of 32 f_S, 48 f_S, or 64 f_S. The DAP only supports a 1 × f_S LRCLK. The timing relationship of these clocks to SDIN is shown in subsequent sections. The clock section uses MCLK or the internal oscillator clock (when MCLK is unstable, out of range, or absent) to produce the internal clock (DCLK) running at 512 times the PWM switching frequency.

The DAP can autodetect and set the internal clock control logic to the appropriate settings for all supported clock rates as defined in the clock control register.

TAS5708 has robust clock error handling that uses the built-in trimmed oscillator clock to quickly detect changes/errors. Once the system detects a clock change/error, it will mute the audio (through a single step mute) and then force PLL to limp using the internal oscillator as a reference clock. Once the clocks are stable, the system will auto detect the new rate and revert to normal operation. During this process, the default volume will be restored in a single step (also called hard unmute). The ramp process can be programmed to ramp back slowly (also called soft unmute) as defined in volume register (0X0E).

PWM Section

The TAS5708 DAP device uses noise-shaping and sophisticated non-linear correction algorithms to achieve high power efficiency and high-performance digital audio reproduction. The DAP uses a fourth-order noise shaper to increase dynamic range and SNR in the audio band. The PWM section accepts 24-bit PCM data from the DAP and outputs two BTL PWM audio output channels.

The PWM section has individual channel dc blocking filters that can be enabled and disabled. The filter cutoff frequency is less than 1 Hz. Individual channel de-emphasis filters for 44.1- and 48-kHz are included and can be enabled and disabled.

Finally, the PWM section has an adjustable maximum modulation limit of 93.8% to 99.2%.

For detailed description of using audio processing features like DRC and EQ, please refer to User's Guide and TAS570X GDE software development tool documentation. Also refer to GDE software development tool for device data path.

I²C COMPATIBLE SERIAL CONTROL INTERFACE

The TAS5708 DAP has an I²C serial control slave interface to receive commands from a system controller. The serial control interface supports both normal-speed (100-kHz) and high-speed (400-kHz) operations without wait states. As an added feature, this interface operates even if MCLK is absent.

The serial control interface supports both single-byte and multi-byte read and write operations for status registers and the general control registers associated with the PWM.

SERIAL INTERFACE CONTROL AND TIMING

I²S Timing

I²S timing uses LRCLK to define when the data being transmitted is for the left channel and when it is for the right channel. LRCLK is low for the left channel and high for the right channel. A bit clock running at 32, 48, or $64 \times f_s$ is used to clock in the data. There is a delay of one bit clock from the time the LRCLK signal changes state to the first bit of data on the data lines. The data is written MSB first and is valid on the rising edge of bit clock. The DAP masks unused trailing data bit positions.

2-Channel I²S (Philips Format) Stereo Input

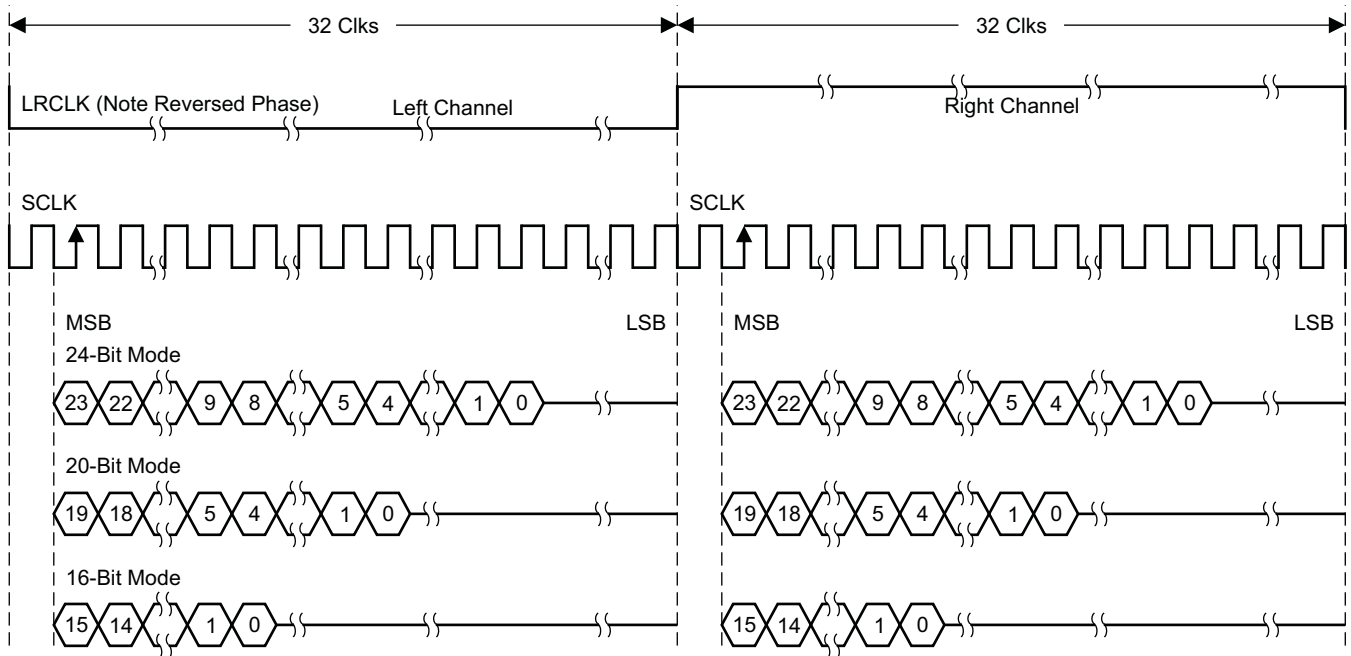

T0034-01

NOTE: All data presented in 2s-complement form with MSB first.

Figure 18. I²S 64-f_s Format

2-Channel I²S (Philips Format) Stereo Input/Output (24-Bit Transfer Word Size)

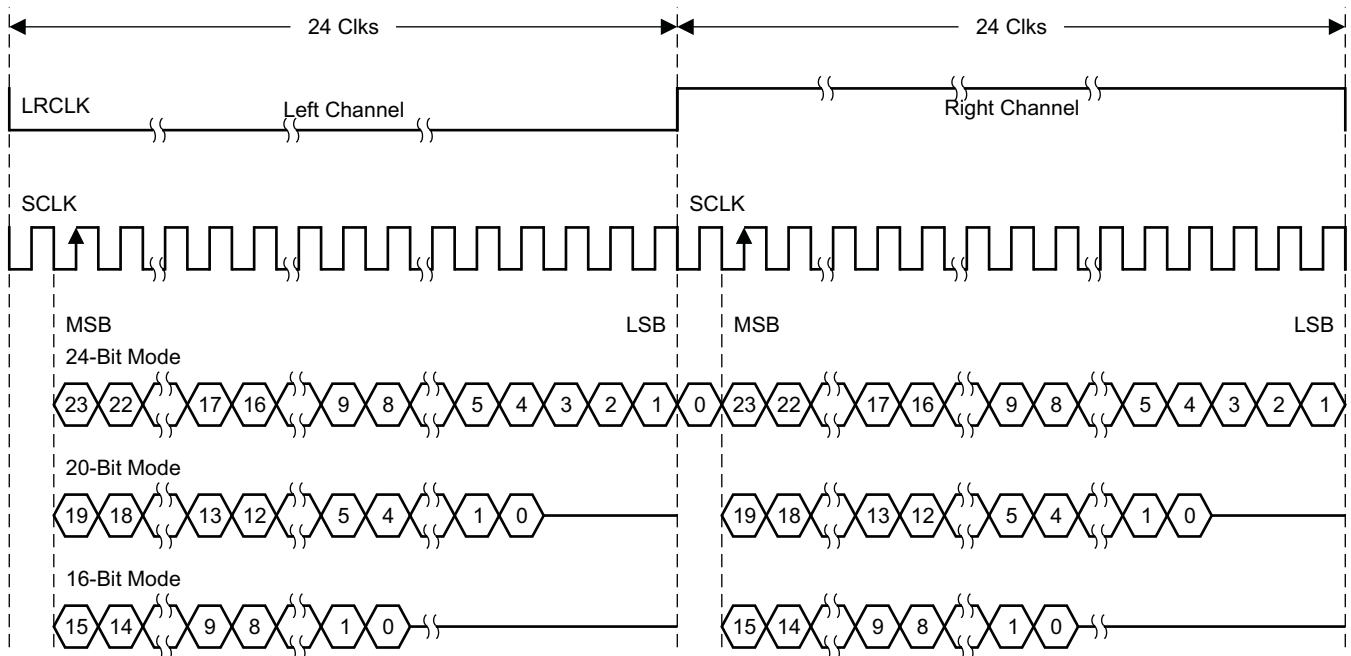

T0092-01

NOTE: All data presented in 2s-complement form with MSB first.

Figure 19. I²S 48-f_s Format

2-Channel I²S (Philips Format) Stereo Input

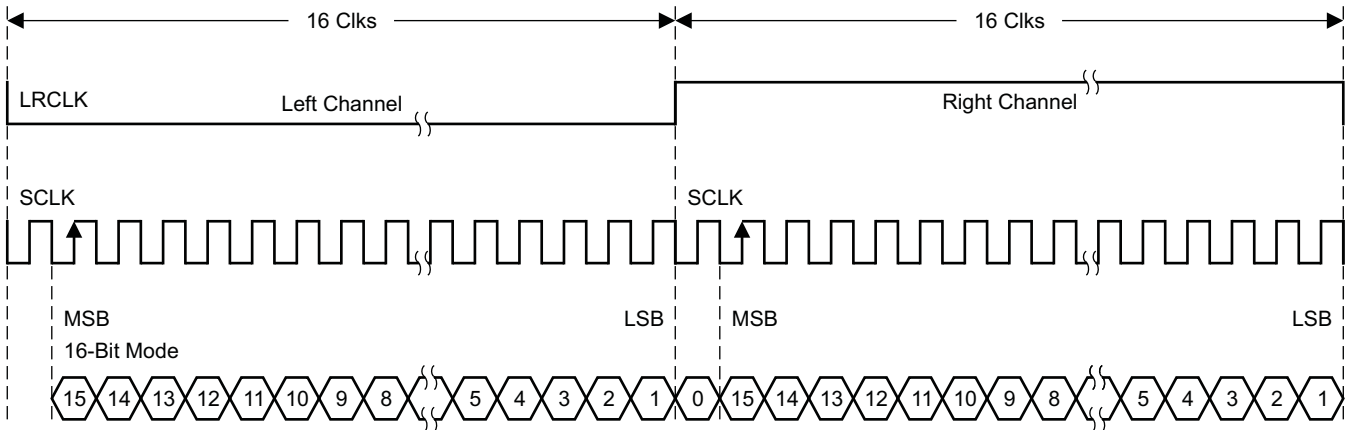

T0266-01

NOTE: All data presented in 2s-complement form with MSB first.

Figure 20. I²S 32-f_s Format

Left-Justified

Left-justified (LJ) timing uses LRCLK to define when the data being transmitted is for the left channel and when it is for the right channel. LRCLK is high for the left channel and low for the right channel. A bit clock running at 32, 48, or 64 × f_s is used to clock in the data. The first bit of data appears on the data lines at the same time LRCLK toggles. The data is written MSB first and is valid on the rising edge of the bit clock. The DAP masks unused trailing data bit positions.

2-Channel Left-Justified Stereo Input

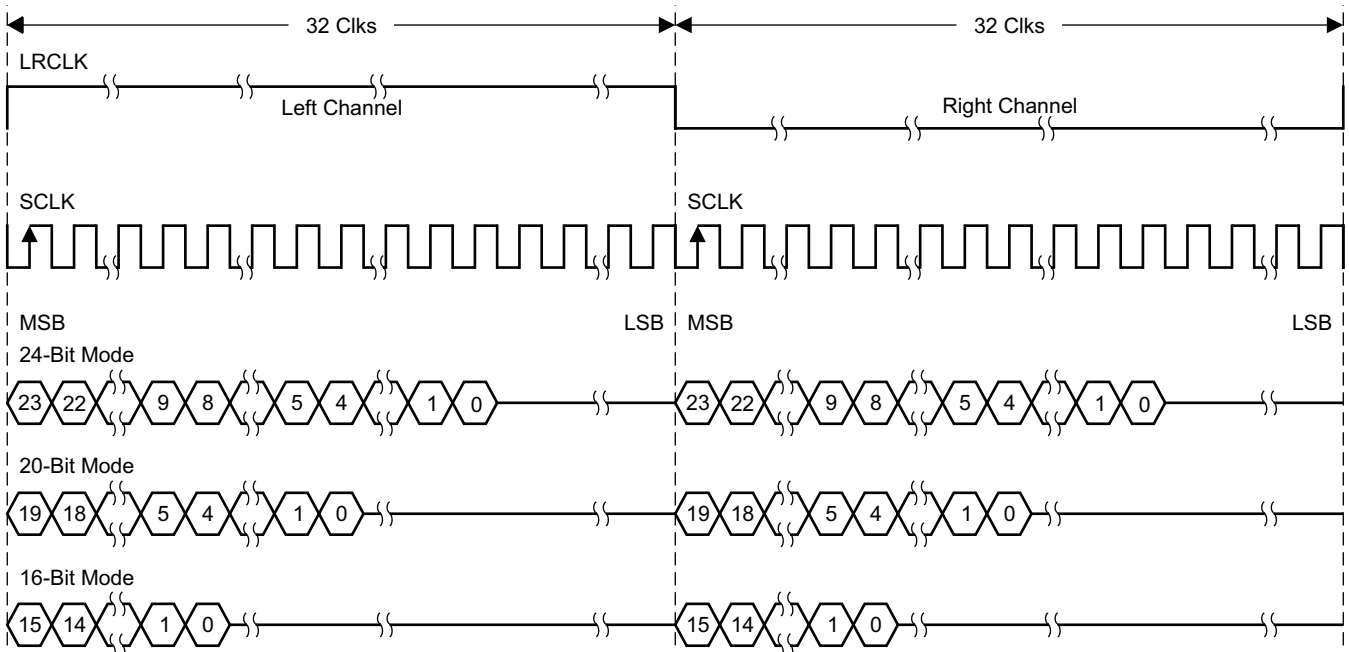

T0034-02

NOTE: All data presented in 2s-complement form with MSB first.

Figure 21. Left-Justified 64-f_s Format

2-Channel Left-Justified Stereo Input (24-Bit Transfer Word Size)

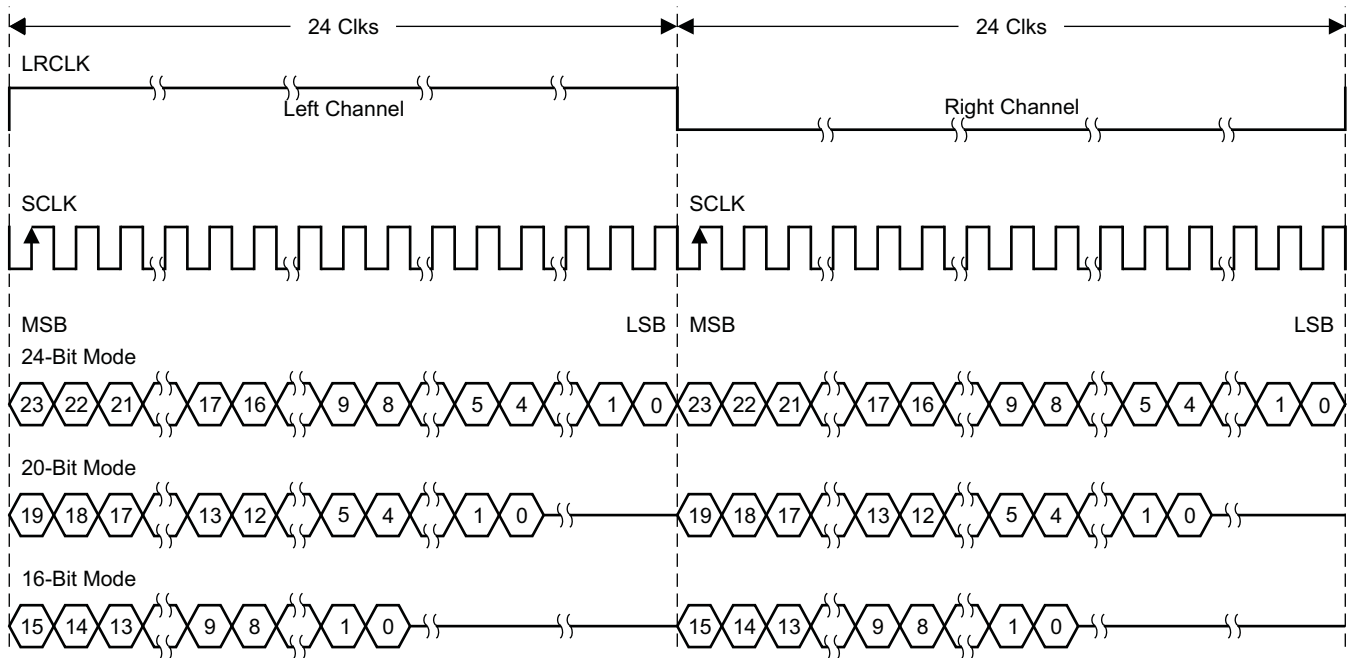

T0092-02

NOTE: All data presented in 2s-complement form with MSB first.

Figure 22. Left-Justified 48-f_s Format

2-Channel Left-Justified Stereo Input

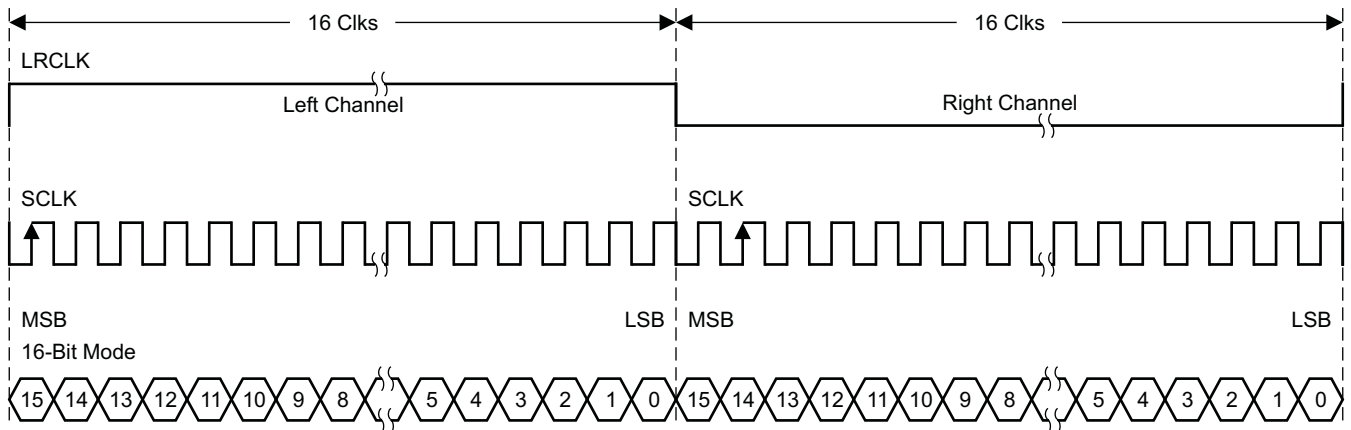

T0266-02

NOTE: All data presented in 2s-complement form with MSB first.

Figure 23. Left-Justified 32-f_s Format

Right-Justified

Right-justified (RJ) timing uses LRCLK to define when the data being transmitted is for the left channel and when

it is for the right channel. LRCLK is high for the left channel and low for the right channel. A bit clock running at $32, 48, \text{ or } 64 \times f_s$ is used to clock in the data. The first bit of data appears on the data 8 bit-clock periods (for 24-bit data) after LRCLK toggles. In RJ mode the LSB of data is always clocked by the last bit clock before LRCLK transitions. The data is written MSB first and is valid on the rising edge of bit clock. The DAP masks unused leading data bit positions.

2-Channel Right-Justified (Sony Format) Stereo Input

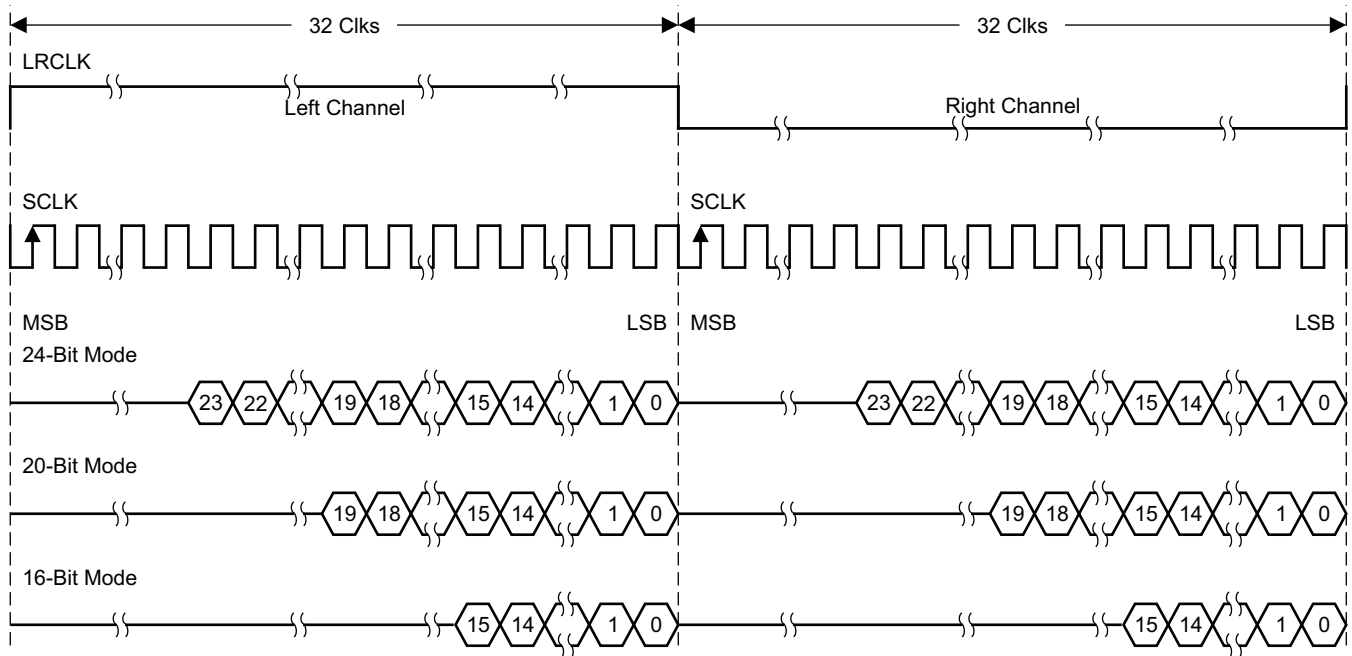

T0034-03

Figure 24. Right Justified 64- f_s Format

2-Channel Right-Justified Stereo Input (24-Bit Transfer Word Size)

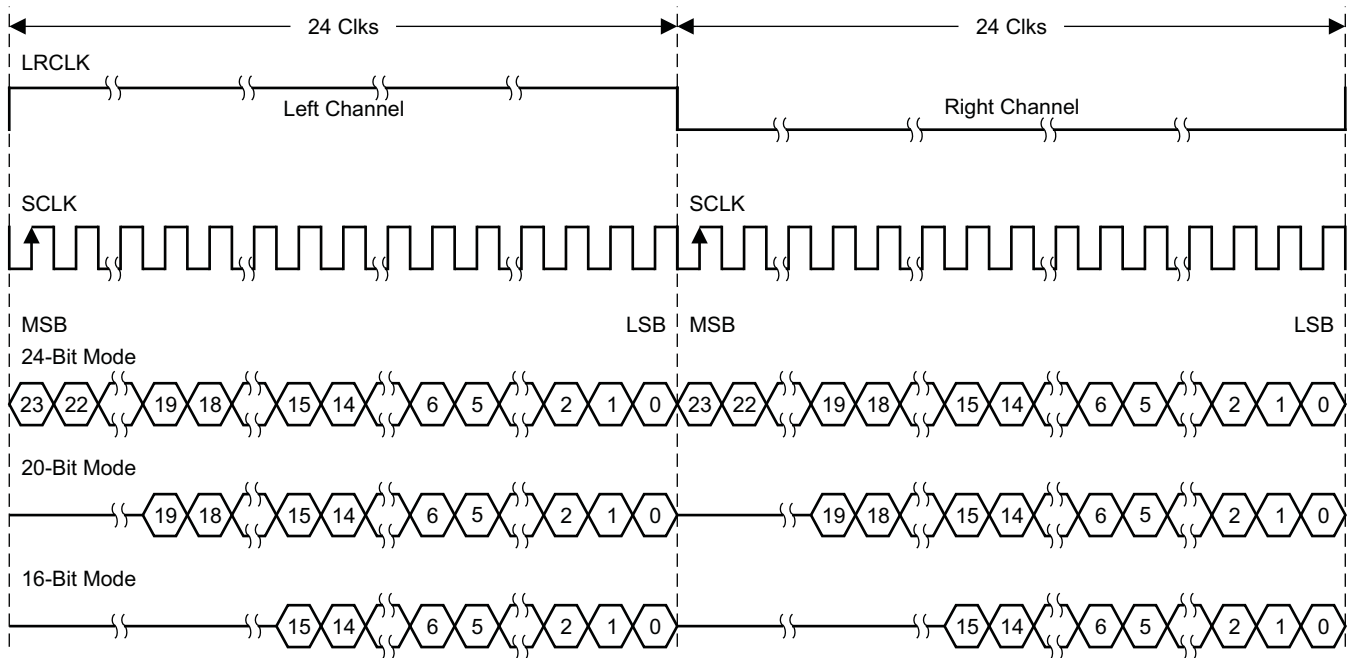

T0092-03

Figure 25. Right Justified 48-f_s Format

2-Channel Right-Justified (Sony Format) Stereo Input

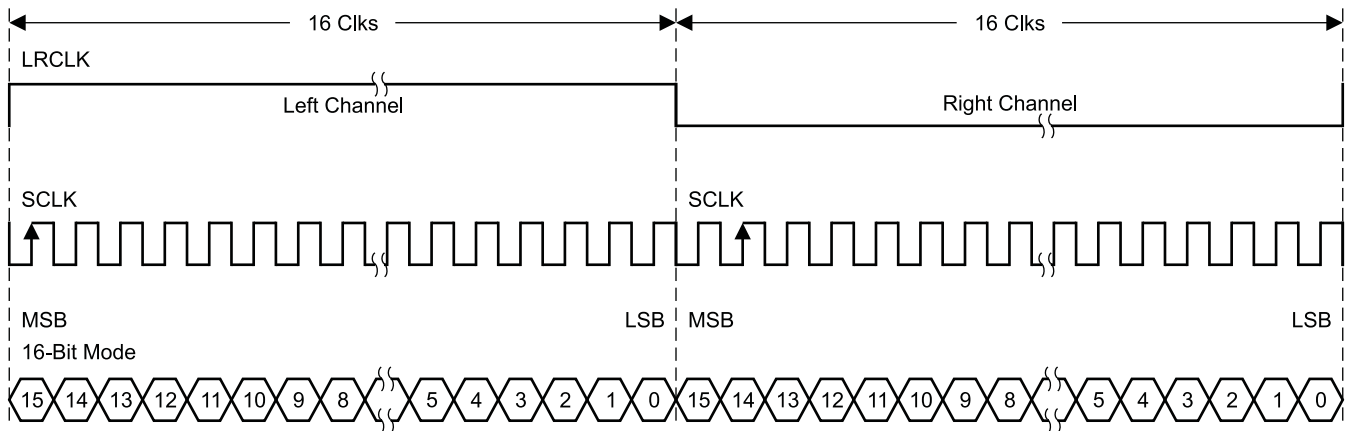

T0266-03

Figure 26. Right Justified 32-f_s Format

I²C SERIAL CONTROL INTERFACE

The TAS5708 DAP has a bidirectional I²C interface that compatible with the I²C (Inter IC) bus protocol and supports both 100-kHz and 400-kHz data transfer rates for single and multiple byte write and read operations. This is a slave only device that does not support a multimaster bus environment or wait state insertion. The control interface is used to program the registers of the device and to read device status.

The DAP supports the standard-mode I²C bus operation (100 kHz maximum) and the fast I²C bus operation (400 kHz maximum). The DAP performs all I²C operations without I²C wait cycles.

General I²C Operation

The I²C bus employs two signals; SDA (data) and SCL (clock), to communicate between integrated circuits in a system. Data is transferred on the bus serially one bit at a time. The address and data can be transferred in byte (8-bit) format, with the most significant bit (MSB) transferred first. In addition, each byte transferred on the bus is acknowledged by the receiving device with an acknowledge bit. Each transfer operation begins with the master device driving a start condition on the bus and ends with the master device driving a stop condition on the bus. The bus uses transitions on the data pin (SDA) while the clock is high to indicate a start and stop conditions. A high-to-low transition on SDA indicates a start and a low-to-high transition indicates a stop. Normal data bit transitions must occur within the low time of the clock period. These conditions are shown in Figure 27. The master generates the 7-bit slave address and the read/write (R/W) bit to open communication with another device and then waits for an acknowledge condition. The TAS5708 holds SDA low during the acknowledge clock period to indicate an acknowledgment. When this occurs, the master transmits the next byte of the sequence. Each device is addressed by a unique 7-bit slave address plus R/W bit (1 byte). All compatible devices share the same signals via a bidirectional bus using a wired-AND connection. An external pullup resistor must be used for the SDA and SCL signals to set the high level for the bus.

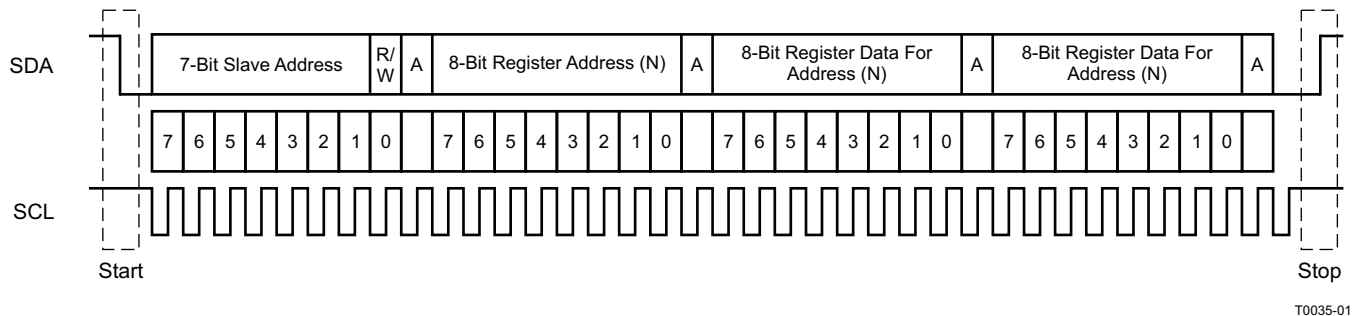

Figure 27. Typical I²C Sequence

There is no limit on the number of bytes that can be transmitted between start and stop conditions. When the last word transfers, the master generates a stop condition to release the bus. A generic data transfer sequence is shown in Figure 27.

The 7-bit address for TAS5708 is 0011 011 (0x36).

TAS5708 address can be changed from 0x36 to 0x38 by writing 0x38 to device address register 0xF9.

Single- and Multiple-Byte Transfers

The serial control interface supports both single-byte and multiple-byte read/write operations for subaddresses 0x00 to 0x1F. However, for the subaddresses 0x20 to 0xFF, the serial control interface supports only multiple-byte read/write operations (in multiples of 4 bytes).

During multiple-byte read operations, the DAP responds with data, a byte at a time, starting at the subaddress assigned, as long as the master device continues to respond with acknowledges. If a particular subaddress does not contain 32 bits, the unused bits are read as logic 0.

During multiple-byte write operations, the DAP compares the number of bytes transmitted to the number of bytes that are required for each specific subaddress. For example, if a write command is received for a biquad subaddress, the DAP expects to receive five 32-bit words. If fewer than five 32-bit data words have been received when a stop command (or another start command) is received, the data received is discarded.

Supplying a subaddress for each subaddress transaction is referred to as random I²C addressing. The TAS5708 also supports sequential I²C addressing. For write transactions, if a subaddress is issued followed by data for that subaddress and the 15 subaddresses that follow, a sequential I²C write transaction has taken place, and the data for all 16 subaddresses is successfully received by the TAS5708. For I²C sequential write transactions, the subaddress then serves as the start address, and the amount of data subsequently transmitted, before a stop or start is transmitted, determines how many subaddresses are written. As was true for random addressing, sequential addressing requires that a complete set of data be transmitted. If only a partial set of data is written to the last subaddress, the data for the last subaddress is discarded. However, all other data written is accepted; only the incomplete data is discarded.

Single-Byte Write

As shown in Figure 28, a single-byte data write transfer begins with the master device transmitting a start condition followed by the I²C device address and the read/write bit. The read/write bit determines the direction of the data transfer. For a write data transfer, the read/write bit will be a 0. After receiving the correct I²C device address and the read/write bit, the DAP responds with an acknowledge bit. Next, the master transmits the address byte or bytes corresponding to the TAS5708 internal memory address being accessed. After receiving the address byte, the TAS5708 again responds with an acknowledge bit. Next, the master device transmits the data byte to be written to the memory address being accessed. After receiving the data byte, the TAS5708 again responds with an acknowledge bit. Finally, the master device transmits a stop condition to complete the single-byte data write transfer.

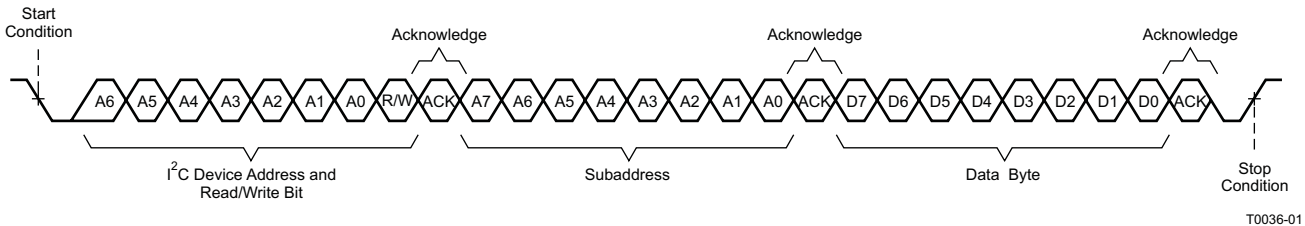

Figure 28. Single-Byte Write Transfer

Multiple-Byte Write

A multiple-byte data write transfer is identical to a single-byte data write transfer except that multiple data bytes are transmitted by the master device to the DAP as shown in Figure 29. After receiving each data byte, the TAS5708 responds with an acknowledge bit.

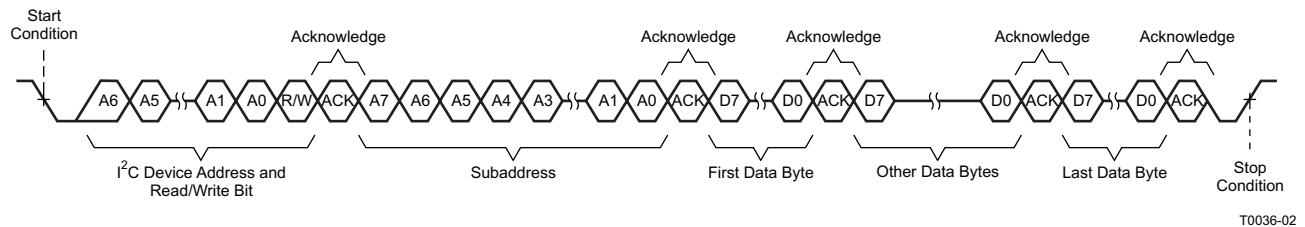

Figure 29. Multiple-Byte Write Transfer

Single-Byte Read

As shown in Figure 30, a single-byte data read transfer begins with the master device transmitting a start condition followed by the I²C device address and the read/write bit. For the data read transfer, both a write followed by a read are actually done. Initially, a write is done to transfer the address byte or bytes of the internal memory address to be read. As a result, the read/write bit becomes a 0. After receiving the TAS5708 address and the read/write bit, TAS5708 responds with an acknowledge bit. In addition, after sending the internal memory address byte or bytes, the master device transmits another start condition followed by the TAS5708 address and the read/write bit again. This time the read/write bit becomes a 1, indicating a read transfer. After receiving the address and the read/write bit, the TAS5708 again responds with an acknowledge bit. Next, the TAS5708 transmits the data byte from the memory address being read. After receiving the data byte, the master device transmits a not acknowledge followed by a stop condition to complete the single byte data read transfer.

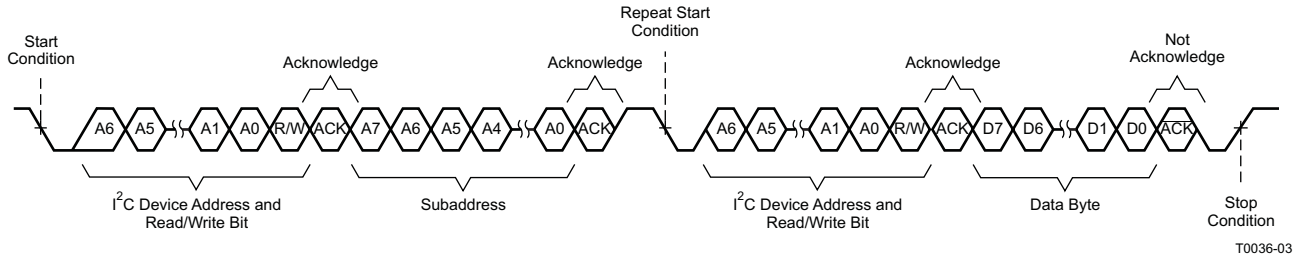

Figure 30. Single-Byte Read Transfer

Multiple-Byte Read

A multiple-byte data read transfer is identical to a single-byte data read transfer except that multiple data bytes are transmitted by the TAS5708 to the master device as shown in Figure 31. Except for the last data byte, the master device responds with an acknowledge bit after receiving each data byte.

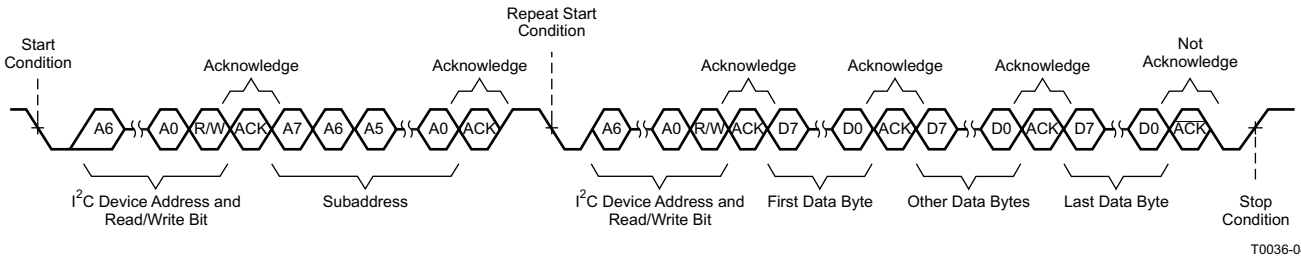
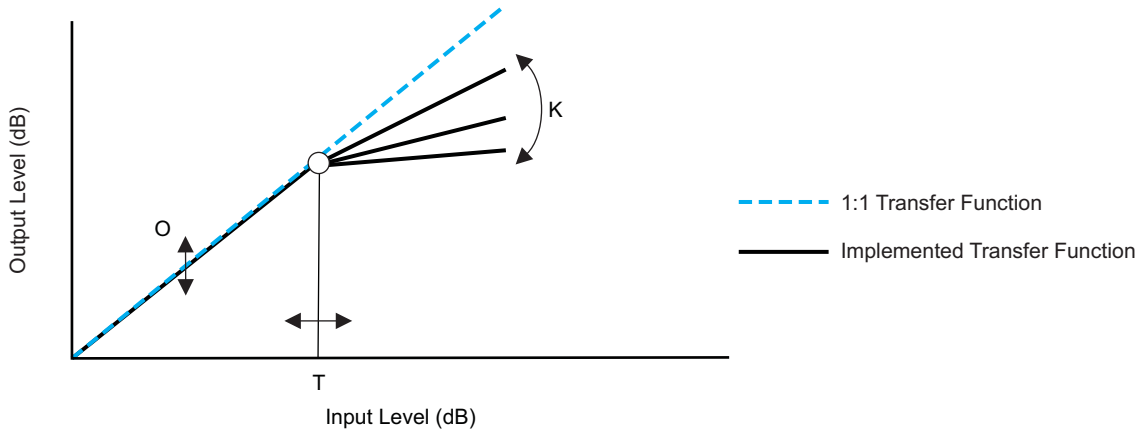

Figure 31. Multiple Byte Read Transfer

Dynamic Range Control (DRC)

The DRC scheme has a single threshold, offset, and slope (all programmable). There is one ganged DRC for the left/right channels.

The DRC input/output diagram is shown in Figure 32.



M0091-02

Professional-quality dynamic range compression automatically adjusts volume to flatten volume level.

- One DRC for left/right
- The DRC has adjustable threshold, offset, and compression levels
- Programmable energy, attack, and decay time constants
- *Transparent compression*: compressors can attack fast enough to avoid apparent clipping before engaging, and decay times can be set slow enough to avoid pumping.

Figure 32. Dynamic Range Control

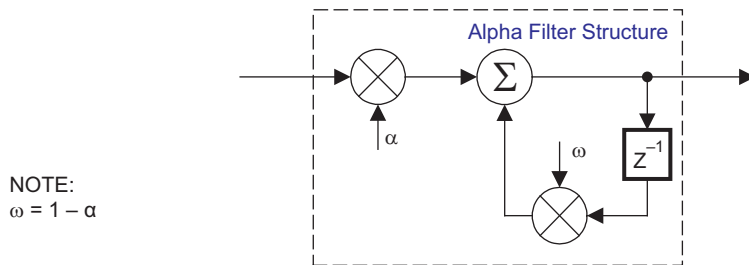
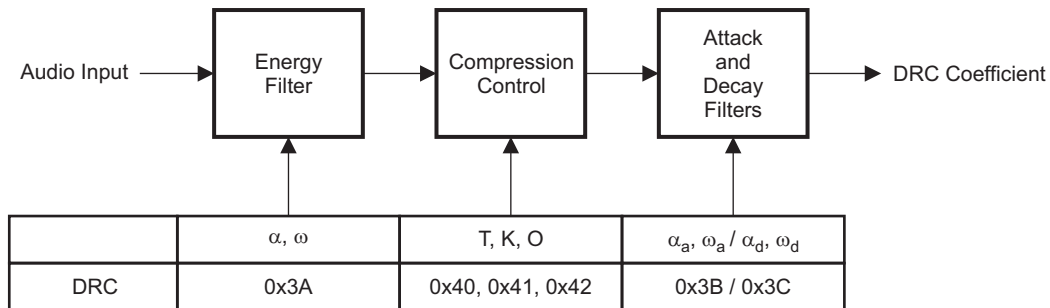

NOTE:
 $\omega = 1 - \alpha$

B0265-03

Figure 33. DRC Structure

BiQuad Structure

All biquads use a 2nd order IIR filter structure as shown below. Each biquad has 3 coefficients on the direct path (b_0, b_1, b_2) and 2 coefficients on feedback path (a_1 and a_2) as shown in the diagram.

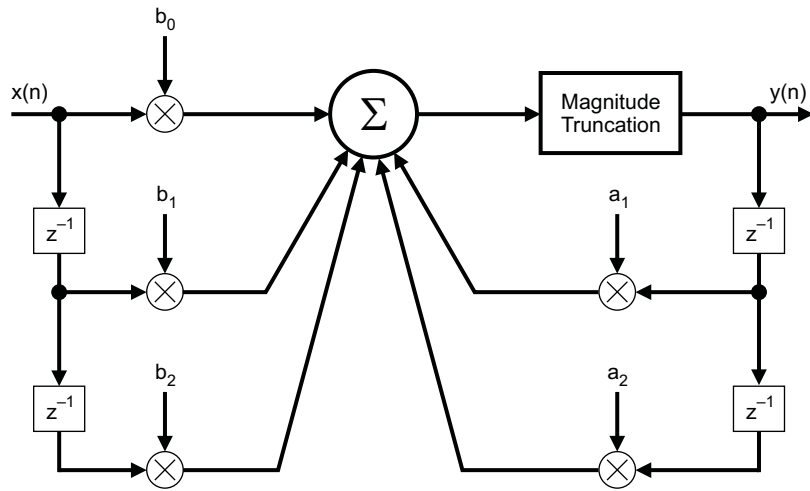

M0012-02

Figure 34. BiQuad Filter

BANK SWITCHING

The TAS5708 uses an approach called *bank switching* together with automatic sample-rate detection. All processing features that must be changed for different sample rates are stored internally in three banks. The user can program which sample rates map to each bank. By default, bank 1 is used in 32kHz mode, bank 2 is used in 44.1/48 kHz mode, and bank 3 is used for all other rates. Combined with the clock-rate autodetection feature, bank switching allows the TAS5708 to detect automatically a change in the input sample rate and switch to the appropriate bank without any MCU intervention.

An external controller configures bankable locations (0x29-0x36 and 0x3A-0x3C) for all three banks during the initialization sequence.

If auto bank switching is enabled (register 0x50, bits 2:0), then the TAS5708 automatically swaps the coefficients for subsequent sample rate changes, avoiding the need for any external controller intervention for a sample rate change.

By default, bits 2:0 have the value 000; indicating that bank switching is disabled. In that state, updates to bankable locations take immediate effect. A write to register 0x50 with bits 2:0 being 001, 010, or 011 brings the system into the coefficient-bank-update state *update bank1*, *update bank2*, or *update bank3*, respectively. Any subsequent write to bankable locations updates the coefficient banks stored outside the DAP. After updating all the three banks, the system controller should issue a write to register 0x50 with bits 2:0 being 100; this changes the system state to automatic bank switching mode. In automatic bank switching mode, the TAS5708 automatically swaps banks based on the sample rate.

Command sequences for updating DAP coefficients can be summarized as follows:

1. **Bank switching disabled (default):** DAP coefficient writes take immediate effect and are not influenced by subsequent sample rate changes.
OR
Bank switching enabled:
 - a. Update bank-1 mode: Write "001" to bits 2:0 of reg 0x50. Load the 32 kHz coefficients.
 - b. Update bank-2 mode: Write "010" to bits 2:0 of reg 0x50. Load the 48 kHz coefficients.
 - c. Update bank-3 mode: Write "011" to bits 2:0 of reg 0x50. Load the other coefficients.
 - d. Enable automatic bank switching by writing "100" to bits 2:0 of reg 0x50.

26-Bit 3.23 Number Format

All mixer gain coefficients are 26-bit coefficients using a 3.23 number format. Numbers formatted as 3.23 numbers means that there are 3 bits to the left of the decimal point and 23 bits to the right of the decimal point. This is shown in [Figure 35](#).

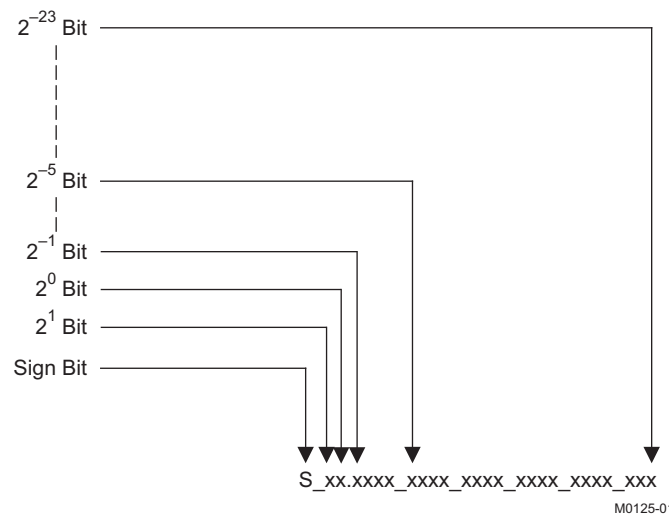

Figure 35. 3.23 Format

The decimal value of a 3.23 format number can be found by following the weighting shown in Figure 35. If the most significant bit is logic 0, the number is a positive number, and the weighting shown yields the correct number. If the most significant bit is a logic 1, then the number is a negative number. In this case every bit must be inverted, a 1 added to the result, and then the weighting shown in Figure 36 applied to obtain the magnitude of the negative number.

$$(1 \text{ or } 0) \times 2^1 + (1 \text{ or } 0) \times 2^0 + (1 \text{ or } 0) \times 2^{-1} + \dots (1 \text{ or } 0) \times 2^{-4} + \dots (1 \text{ or } 0) \times 2^{-23}$$

M0126-01

Figure 36. Conversion Weighting Factors—3.23 Format to Floating Point

Gain coefficients, entered via the I2C bus, must be entered as 32-bit binary numbers. The format of the 32-bit number (4-byte or 8-digit hexadecimal number) is shown in Figure 37

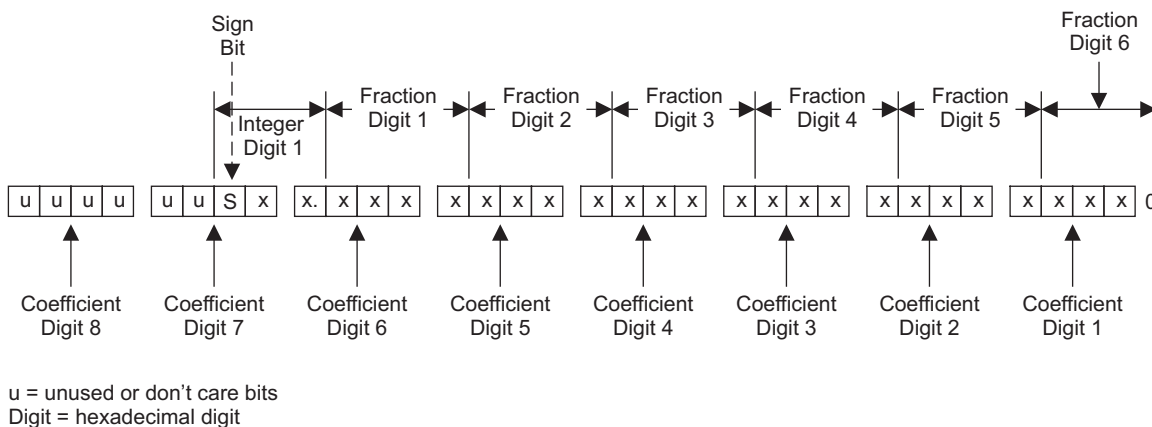

Figure 37. Alignment of 3.23 Coefficient in 32-Bit I2C Word

Sample calculation for 3.23 format

db	Linear	Decimal	Hex (3.23 Format)
0	1	8388608	00800000
5	1.7782794	14917288	00E39EA8
-5	0.5623413	4717260	0047FACC
X	$L = 10^{(X/20)}$	$D = 8388608 \times L$	$H = \text{dec2hex}(D, 8)$

Sample calculation for 9.17 format

db	Linear	Decimal	Hex (9.17 Format)
0	1	131072	00020000
5	1.7782794	233082.6	00038E7A
-5	0.5623413	73707.2	00011FEB
X	$L = 10^{(X/20)}$	$D = 131072 \times L$	$H = \text{dec2hex}(D, 8)$

APPLICATION INFORMATION

Calculation of Output Signal Level of TAS5708 Feedback Power Stage (Gain Is independent of PVCC)

The gain of the TAS5708 is the total digital gain of the controller multiplied by the gain of the power stage.

For a half-bridge channel of the TAS5708 power stage, the gain is simply:

$$\text{Power stage gain} = 13 \times V_{\text{RMS}} / \text{Modulation Level}$$

Modulation level = fraction of full-scale modulation of the PWM signal at the input of the power stage.

$$V_{\text{RMS}}(\text{SE}) = \text{Audio voltage level at the output of the power stage} = 13 \times \text{Modulation Level}$$

$$V_{\text{RMS}}(\text{BTL}) = 2 \times \text{Audio voltage level at the output of the power stage} = 26 \times \text{Modulation Level}$$

For the TAS5708 controller, the gain is the programmed digital gain multiplied by a scaling factor, called the *maximum modulation level*. The maximum modulation level is derived from the modulation limit programmed in the controller, which limits duty cycle to a set number of percent above 0% and below 100%. Setting the modulation limit to 97.7% (default) limits the duty cycle between 2.3% and 97.7%.

$$\text{Controller gain} = \text{digital gain} \times \text{maximum modulation level} \times (\text{modulation level/digital FFS})$$

$$\text{Digital FFS} = \text{digital input fraction of full scale}$$

$$\text{Modulation limit} = 97.7\%$$

$$\text{Maximum modulation level} = 2 \times \text{modulation limit} - 1 = 0.954$$

The output signal level of the TAS5708 can now be calculated:

$$V_{\text{RMS}}(\text{SE}) = \text{digital FFS} \times \text{digital gain} \times \text{maximum modulation level} \times 13$$

$$V_{\text{RMS}}(\text{BTL}) = 2 \times V_{\text{RMS}}(\text{SE})$$

With the modulation limit set at the default level of 97.7%, this becomes:

$$V_{\text{RMS}}(\text{BTL}) = \text{digital FFS} \times \text{digital gain} \times 24.8$$

Example: Input = -20 dBFS; volume = 0 dB; biquads = ALL PASS; modulation index = 97.7%; mode = BTL

Output $V_{\text{RMS}}(\text{BTL}) = 24.8 \times 0.1 \times 1 = 2.48 \text{ V}$.

Recommended Use Model

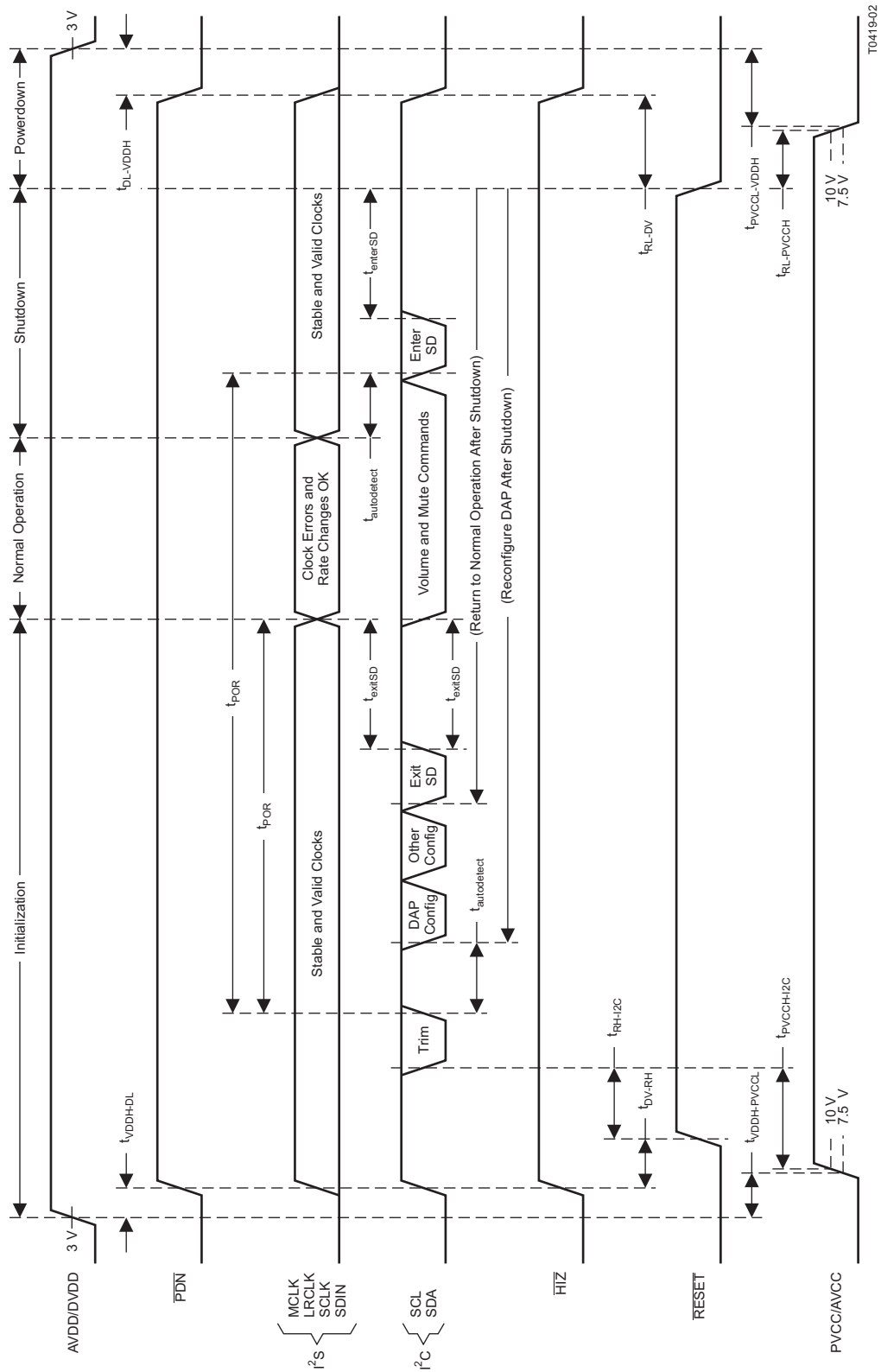

Figure 38. Recommended Command Sequence

PARAMETER	DESCRIPTION	MIN	TYP	MAX	UNIT
$t_{VDDH-DL}$	Time digital inputs must remain low after AVDD/DVDD goes above 3V	0			μs
$t_{DL-VDDH}$	Time digital inputs must be low before AVDD/DVDD goes below 3V	0			μs
$t_{VDDH-PVCC}$	Time PVCC/AVCC remains below 7.5V after AVDD/DVDD goes above 3V	100			μs
$t_{PVCC-L-VDDH}$	Time PVCC/AVCC must be below 7.5V before AVDD/DVDD goes below 3V	0			μs
$t_{PVCC-H-I2C}$	Time PVCC/AVCC must be above 10V before I2C commands may address device	10			μs
$t_{RL-PVCC}$	Time PVCC/AVCC must remain above 10V after $\overline{\text{RESET}}$ goes low	2			μs
t_{RH-I2C}	Time $\overline{\text{RESET}}$ must be high before I2C commands may address device	13.5			ms
t_{DV-RH}	Time digital inputs must be valid (driven as recommended) before $\overline{\text{RESET}}$ goes high	100			μs
t_{RL-DV}	Time digital inputs must remain valid (driven as recommended) after $\overline{\text{RESET}}$ goes low	2			μs
$t_{\text{autodetect}}$	Autodetect completion wait time (given stable and valid clocks) before issuing further commands	50			ms
t_{exitSD}	Exit shutdown wait time before issuing further commands to device (t_{start} given by register 0x1A)	$1+1.3*t_{\text{start}}$			ms
t_{enterSD}	Enter shutdown wait time before issuing further commands to device (t_{stop} given by register 0x1A)	$1+1.3*t_{\text{stop}}$			ms
t_{POR}	Power-on-reset wait time after 1st trim following AVDD/DVDD power-up (t_{start} given by register 0x1A) (does not apply to trim commands following subsequent resets)	$240+1.3*t_{\text{start}}$			ms

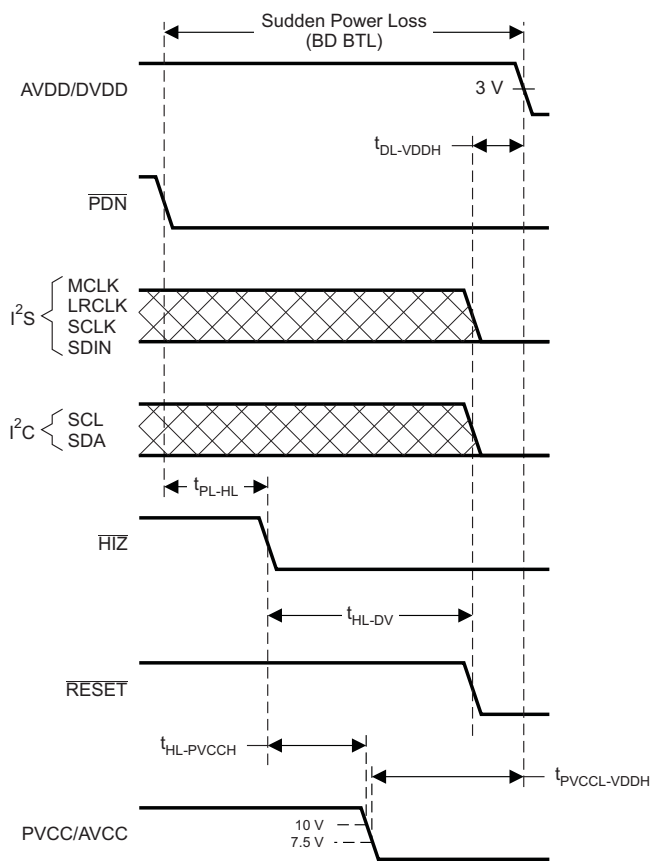

Figure 39. BD BTL Power Loss Sequence

T0420-02

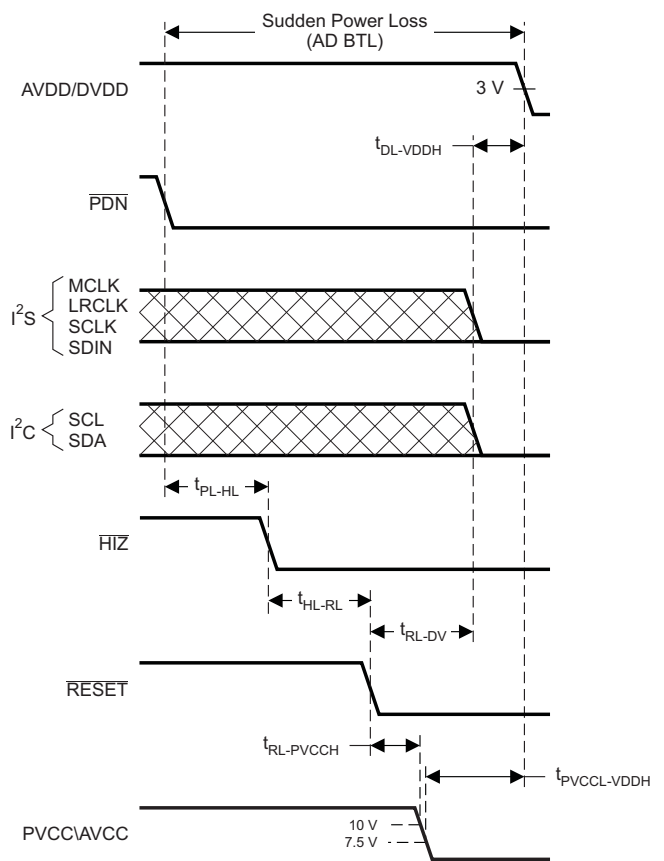

Figure 40. AD BTL Power Loss Sequence

T0420-03

PARAMETER	DESCRIPTION	MIN	TYP	MAX	UNIT
t_{PL-HL}	Time \overline{HIZ} must remain high after \overline{PDN} goes low	2			ms
t_{HL-RL}	Time \overline{RESET} must remain high after \overline{HIZ} goes low	4			μ s
t_{HL-DV}	Time digital inputs must remain valid (driven as recommended) after \overline{HIZ} goes low	4			μ s
t_{RL-DV}	Time digital inputs must remain valid (driven as recommended) after \overline{RESET} goes low	2			μ s
$t_{DL-VDDH}$	Time digital inputs must be low before AVDD/DVDD goes below 3V	0			μ s
$t_{HL-PVCC}$	Time PVCC/AVCC must remain above 10V after \overline{HIZ} goes low	4			μ s
$t_{RL-PVCC}$	Time PVCC/AVCC must remain above 10V after \overline{RESET} goes low	2			μ s
$t_{PVCC-L-VDDH}$	Time PVCC/AVCC must be below 7.5V before AVDD/DVDD goes below 3V	0			μ s

Recommended Command Sequences

The DAP has two groups of commands. One set is for configuration and is intended for use only during initialization. The other set has built-in click and pop protection and may be used during normal operation while audio is streaming. The following supported command sequences illustrate how to initialize, operate, and shutdown the device.

Initialization Sequence

Use the following sequence to power-up and initialize the device:

1. Hold all digital inputs low and ramp up AVDD/DVDD to at least 3V.
2. Initialize digital inputs and PVCC/AVCC supply as follows:
 - Drive $\overline{RESET}=0$, $\overline{PDN}=1$, $\overline{HIZ}=1$, and other digital inputs to their desired state, observing absolute maximum ratings relative to AVDD/DVDD. Provide stable and valid I2S clocks (MCLK, LRCLK, and SCLK). Wait at least 100 μ s, drive $\overline{RESET}=1$, and wait at least another 13.5ms.
 - Ramp up PVCC/AVCC to at least 10V while ensuring it remains below 7.5V for at least 100 μ s after AVDD/DVDD reaches 3V. Then wait at least another 10 μ s.
3. Trim oscillator (write 0x00 to register 0x1B) and wait at least 50ms.
4. Configure the DAP via I2C (see Users's Guide for typical values):
 - Biquads (0x29-36)
 - DRC parameters (0x3A-3C, 0x40-42, and 0x46)
 - Bank select (0x50)
5. Configure remaining registers
6. Exit shutdown (sequence defined below).

Normal Operation

The following are the only events supported during normal operation:

- (a) Writes to master/channel volume registers
- (b) Writes to soft mute register
- (c) Enter and exit shutdown (sequence defined below)
- (d) Clock errors and rate changes

Note: Events (c) and (d) are not supported for $240\text{ms} + 1.3 \cdot t_{\text{start}}$ after trim following AVDD/DVDD powerup ramp (where t_{start} is specified by register 0x1A).

Shutdown Sequence

Enter:

1. Ensure I2S clocks have been stable and valid for at least 50ms.

2. Write 0x40 to register 0x05.
3. Wait at least $1\text{ms} + 1.3 \cdot t_{\text{stop}}$ (where t_{stop} is specified by register 0x1A).
4. Once in shutdown, stable clocks are not required while device remains idle.
5. If desired, reconfigure by ensuring that clocks have been stable and valid for at least 50ms before returning to step 4 of initialization sequence.

Exit:

1. Ensure I2S clocks have been stable and valid for at least 50ms.
2. Write 0x00 to register 0x05 (exit shutdown command may not be serviced for as much as 240ms after trim following AVDD/DVDD powerup ramp).
3. Wait at least $1\text{ms} + 1.3 \cdot t_{\text{start}}$ (where t_{start} is specified by register 0x1A).
4. Proceed with normal operation.

Controlled Powerdown Sequence

Use the following sequence to powerdown the device and its supplies when time permits a controlled shutdown:

1. Enter shutdown (sequence defined above).
2. Assert $\overline{\text{RESET}}=0$.
3. Drive digital inputs low and ramp down PVCC/AVCC supply as follows:
 - Drive all digital inputs low after $\overline{\text{RESET}}$ has been low for at least 2 μs .
 - Ramp down PVCC/AVCC while ensuring that it remains above 10V until $\overline{\text{RESET}}$ has been low for at least 2 μs .
4. Ramp down AVDD/DVDD while ensuring that it remains above 3V until PVCC/AVCC is below 7.5V and observing absolute maximum ratings for digital inputs.

Power Loss Sequence (BD BTL)

Use the following sequence to powerdown a BD BTL device and its supplies in case of sudden power loss when time does not permit a controlled shutdown:

1. Assert $\overline{\text{PDN}} = 0$ and wait at least 2ms.
2. Assert $\overline{\text{HIZ}} = 0$.
3. Drive digital inputs low and ramp down PVCC/AVCC supply as follows:
 - Drive all digital inputs low after $\overline{\text{HIZ}}$ has been low for at least 4 μs .
 - Ramp down PVCC/AVCC while ensuring that it remains above 10V until $\overline{\text{HIZ}}$ has been low for at least 4 μs .
4. Ramp down AVDD/DVDD while ensuring that it remains above 3V until PVCC/AVCC is below 7.5V and observing absolute maximum ratings for digital inputs.

Power Loss Sequence (AD BTL)

Use the following sequence to powerdown an AD BTL device and its supplies in case of sudden power loss when time does not permit a controlled shutdown:

1. Assert $\overline{\text{PDN}} = 0$ and wait at least 2ms then assert $\overline{\text{HIZ}} = 0$ and wait at least 4 μs .
2. Assert $\overline{\text{RESET}} = 0$.
3. Drive digital inputs low and ramp down PVCC/AVCC supply as follows:
 - Drive all digital inputs low after $\overline{\text{RESET}}$ has been low for at least 2 μs .
 - Ramp down PVCC/AVCC while ensuring that it remains above 10V until $\overline{\text{RESET}}$ has been low for at least 2 μs .

4. Ramp down AVDD/DVDD while ensuring that it remains above 3V until PVCC/AVCC is below 7.5V and observing absolute maximum ratings for digital inputs.

Table 2. Serial Control Interface Register Summary⁽¹⁾

SUBADDRESS	REGISTER NAME	NO. OF BYTES	CONTENTS	INITIALIZATION VALUE
			A u indicates unused bits.	
0x00	Clock control register	1	Description shown in subsequent section	0x6C
0x01	Device ID register	1	Description shown in subsequent section	0x68
0x02	Error status register	1	Description shown in subsequent section	0x00
0x03	System control register 1	1	Description shown in subsequent section	0xA0
0x04	Serial data interface register	1	Description shown in subsequent section	0x05
0x05	System control register 2	1	Description shown in subsequent section	0x40
0x06	Soft mute register	1	Description shown in subsequent section	0x00
0x07	Master volume	1	Description shown in subsequent section	0xFF (mute)
0x08	Channel 1 vol	1	Description shown in subsequent section	0x30 (0 dB)
0x09	Channel 2 vol	1	Description shown in subsequent section	0x30 (0 dB)
0x0A	Fine master volume	1	Description shown in subsequent section	0x00 (0 dB)
0x0B - 0x0D		1	Reserved ⁽²⁾	
0x0E	Volume configuration register	1	Description shown in subsequent section	0x91
0x0F		1	Reserved ⁽²⁾	
0x10	Modulation limit register	1	Description shown in subsequent section	0x02
0x11	IC delay channel 1	1	Description shown in subsequent section	0x4C
0x12	IC delay channel 2	1	Description shown in subsequent section	0x34
0x13	IC delay channel 3	1	Description shown in subsequent section	0x1C
0x14	IC delay channel 4	1	Description shown in subsequent section	0x64
0x15-0x19		1	Reserved ⁽²⁾	
0x1A	Start/stop period register	1	Description shown in subsequent section	0x0A
0x1B	Oscillator trim register	1	Description shown in subsequent section	0x82
0x1C	BKND_ERR register	1	Description shown in subsequent section	0x02
0x1D–0x1F		1	Reserved ⁽²⁾	
0x20	Input MUX register	4	Description shown in subsequent section	0x 0089 777A
0x21-0x24		4	Reserved ⁽²⁾	
0x25	PWM MUX register	4	Description shown in subsequent section	0x0102 1345
0x26-0x28		4	Reserved ⁽²⁾	
0x29	ch1_bq[0]	20	u[31:26], b0[25:0]	0x0080 0000
			u[31:26], b1[25:0]	0x0000 0000
			u[31:26], b2[25:0]	0x0000 0000
			u[31:26], a1[25:0]	0x0000 0000
			u[31:26], a2[25:0]	0x0000 0000
0x2A	ch1_bq[1]	20	u[31:26], b0[25:0]	0x0080 0000
			u[31:26], b1[25:0]	0x0000 0000
			u[31:26], b2[25:0]	0x0000 0000
			u[31:26], a1[25:0]	0x0000 0000
			u[31:26], a2[25:0]	0x0000 0000

(1) Reserved registers should not be accessed.

(2) Reserved registers should not be accessed.

Table 2. Serial Control Interface Register Summary (continued)

SUBADDRESS	REGISTER NAME	NO. OF BYTES	CONTENTS	INITIALIZATION VALUE
0x2B	ch1_bq[2]	20	u[31:26], b0[25:0]	0x0080 0000
			u[31:26], b1[25:0]	0x0000 0000
			u[31:26], b2[25:0]	0x0000 0000
			u[31:26], a1[25:0]	0x0000 0000
			u[31:26], a2[25:0]	0x0000 0000
0x2C	ch1_bq[3]	20	u[31:26], b0[25:0]	0x0080 0000
			u[31:26], b1[25:0]	0x0000 0000
			u[31:26], b2[25:0]	0x0000 0000
			u[31:26], a1[25:0]	0x0000 0000
			u[31:26], a2[25:0]	0x0000 0000
0x2D	ch1_bq[4]	20	u[31:26], b0[25:0]	0x0080 0000
			u[31:26], b1[25:0]	0x0000 0000
			u[31:26], b2[25:0]	0x0000 0000
			u[31:26], a1[25:0]	0x0000 0000
			u[31:26], a2[25:0]	0x0000 0000
0x2E	ch1_bq[5]	20	u[31:26], b0[25:0]	0x0080 0000
			u[31:26], b1[25:0]	0x0000 0000
			u[31:26], b2[25:0]	0x0000 0000
			u[31:26], a1[25:0]	0x0000 0000
			u[31:26], a2[25:0]	0x0000 0000
0x2F	ch1_bq[6]	20	u[31:26], b0[25:0]	0x0080 0000
			u[31:26], b1[25:0]	0x0000 0000
			u[31:26], b2[25:0]	0x0000 0000
			u[31:26], a1[25:0]	0x0000 0000
			u[31:26], a2[25:0]	0x0000 0000
0x30	ch2_bq[0]	20	u[31:26], b0[25:0]	0x0080 0000
			u[31:26], b1[25:0]	0x0000 0000
			u[31:26], b2[25:0]	0x0000 0000
			u[31:26], a1[25:0]	0x0000 0000
			u[31:26], a2[25:0]	0x0000 0000
0x31	ch2_bq[1]	20	u[31:26], b0[25:0]	0x0080 0000
			u[31:26], b1[25:0]	0x0000 0000
			u[31:26], b2[25:0]	0x0000 0000
			u[31:26], a1[25:0]	0x0000 0000
			u[31:26], a2[25:0]	0x0000 0000
0x32	ch2_bq[2]	20	u[31:26], b0[25:0]	0x0080 0000
			u[31:26], b1[25:0]	0x0000 0000
			u[31:26], b2[25:0]	0x0000 0000
			u[31:26], a1[25:0]	0x0000 0000
			u[31:26], a2[25:0]	0x0000 0000
0x33	ch2_bq[3]	20	u[31:26], b0[25:0]	0x0080 0000
			u[31:26], b1[25:0]	0x0000 0000
			u[31:26], b2[25:0]	0x0000 0000
			u[31:26], a1[25:0]	0x0000 0000
			u[31:26], a2[25:0]	0x0000 0000

Table 2. Serial Control Interface Register Summary (continued)

SUBADDRESS	REGISTER NAME	NO. OF BYTES	CONTENTS	INITIALIZATION VALUE
0x34	ch2_bq[4]	20	u[31:26], b0[25:0]	0x0080 0000
			u[31:26], b1[25:0]	0x0000 0000
			u[31:26], b2[25:0]	0x0000 0000
			u[31:26], a1[25:0]	0x0000 0000
			u[31:26], a2[25:0]	0x0000 0000
0x35	ch2_bq[5]	20	u[31:26], b0[25:0]	0x0080 0000
			u[31:26], b1[25:0]	0x0000 0000
			u[31:26], b2[25:0]	0x0000 0000
			u[31:26], a1[25:0]	0x0000 0000
			u[31:26], a2[25:0]	0x0000 0000
0x36	ch2_bq[6]	20	u[31:26], b0[25:0]	0x0080 0000
			u[31:26], b1[25:0]	0x0000 0000
			u[31:26], b2[25:0]	0x0000 0000
			u[31:26], a1[25:0]	0x0000 0000
			u[31:26], a2[25:0]	0x0000 0000
0x37 - 0x39			Reserved ⁽³⁾	
0x3A	DRC ae ⁽⁴⁾	8	u[31:26], ae[25:0]	0x0080 0000
	DRC (1 – ae)		u[31:26], (1 – ae)[25:0]	0x0000 0000
0x3B	DRC aa	8	u[31:26], aa[25:0]	0x0080 0000
	DRC (1 – aa)		u[31:26], (1 – aa)[25:0]	0x0000 0000
0x3C	DRC ad	8	u[31:26], ad[25:0]	0x0080 0000
	DRC (1 – ad)		u[31:26], (1 – ad)[25:0]	0x0000 0000
0x3D–0x3F			Reserved ⁽²⁾	
0x40	DRC-T	4	T[31:0] (9.23 format)	0xFDA2 1490
0x41	DRC-K	4	u[31:26], K[25:0]	0x0384 2109
0x42	DRC-O	4	u[31:26], O[25:0]	0x0008 4210
0x43–0x45			Reserved ⁽²⁾	
0x46	DRC control	4	Description shown in subsequent section	0x0000 0000
0x47–0x4F			Reserved ⁽²⁾	
0x50	Bank switch control	4	Description shown in subsequent section	0x0F70 8000
0x51–0xF8			Reserved ⁽²⁾	
0xF9	Update Device Address	4	u[31:8], New Dev Id[7:0] (New Dev Id = 0x38)	0x00000036
0xFA-0xFF			Reserved ⁽²⁾	

(3) Reserved registers should not be accessed.

(4) "ae" stands for ∞ of energy filter, "aa" stands for ∞ of attack filter and "ad" stands for ∞ of decay filter and $1 - \infty = \omega$.

Note: All DAP coefficients are 3.23 format unless specified otherwise

CLOCK CONTROL REGISTER (0x00)

The clocks and data rates are automatically determined by the TAS5708. The clock control register contains the auto-detected clock status. Bits D7–D5 reflect the sample rate. Bits D4–D2 reflect the MCLK frequency. TAS5708 accepts a 64 Fs or 32 Fs SCLK rate for all MCLK ratios, but accepts a 48Fs SCLK rate only for MCLK ratios of 192 Fs and 384 Fs.

Table 3. Clock Control Register (0x00)

D7	D6	D5	D4	D3	D2	D1	D0	FUNCTION
0	0	0	–	–	–	–	–	$f_S = 32\text{-kHz}$ sample rate
0	0	1	–	–	–	–	–	Reserved ⁽¹⁾
0	1	0	–	–	–	–	–	Reserved ⁽¹⁾
0	1	1	–	–	–	–	–	$f_S = 44.1/48\text{-kHz}$ sample rate ⁽²⁾
1	0	0	–	–	–	–	–	$f_S = 16\text{-kHz}$ sample rate
1	0	1	–	–	–	–	–	$f_S = 22.05/24\text{-kHz}$ sample rate
1	1	0	–	–	–	–	–	$f_S = 8\text{-kHz}$ sample rate
1	1	1	–	–	–	–	–	$f_S = 11.025/12\text{-kHz}$ sample rate
–	–	–	0	0	0	–	–	MCLK frequency = $64 \times f_S$ ⁽³⁾
–	–	–	0	0	1	–	–	MCLK frequency = $128 \times f_S$ ⁽³⁾
–	–	–	0	1	0	–	–	MCLK frequency = $192 \times f_S$ ⁽⁴⁾
–	–	–	0	1	1	–	–	MCLK frequency = $256 \times f_S$ ⁽²⁾⁽⁵⁾
–	–	–	1	0	0	–	–	MCLK frequency = $384 \times f_S$
–	–	–	1	0	1	–	–	MCLK frequency = $512 \times f_S$
–	–	–	1	1	0	–	–	Reserved ⁽¹⁾
–	–	–	1	1	1	–	–	Reserved ⁽¹⁾
–	–	–	–	–	–	0	–	Reserved⁽¹⁾
–	–	–	–	–	–	–	0	Reserved ⁽¹⁾

(1) Reserved registers should not be accessed.

(2) Default values are in **bold**.

(3) Only available for 44.1 kHz and 48 kHz rates.

(4) Rate only available for 32/44.1/48 KHz sample rates

(5) Not available at 8 kHz

DEVICE ID REGISTER (0x01)

The device ID register contains the ID code for the firmware revision.

Table 4. General Status Register (0x01)

D7	D6	D5	D4	D3	D2	D1	D0	FUNCTION
X	–	–	–	–	–	–	–	Reserved
–	1	1	0	1	0	0	0	Identification code

ERROR STATUS REGISTER (0x02)

The error bits are sticky and are not cleared by the hardware. This means that the software must clear the register (write zeroes) and then read them to determine if they are persistent errors.

Error Definitions:

- MCLK Error : MCLK frequency is changing. The number of MCLKs per LRCLK is changing.
- SCLK Error: The number of SCLKs per LRCLK is changing.
- LRCLK Error: LRCLK frequency is changing.
- Frame Slip: LRCLK phase is drifting with respect to internal Frame Sync.

Table 5. Error Status Register (0x02)

D7	D6	D5	D4	D3	D2	D1	D0	FUNCTION
1	-	-	-	-	-	-	-	MCLK error
-	1	-	-	-	-	-	-	PLL autolock error
-	-	1	-	-	-	-	-	SCLK error
-	-	-	1	-	-	-	-	LRCLK error
-	-	-	-	1	-	-	-	Frame slip
-	-	-	-	-	-	1	-	Over current error
0	0	0	0	0	0	0	-	No errors ⁽¹⁾

(1) Default values are in **bold**.

SYSTEM CONTROL REGISTER 1 (0x03)

The system control register 1 has several functions:

Bit D7: If 0, the dc-blocking filter for each channel is disabled.

If 1, the dc-blocking filter (-3 dB cutoff <1 Hz) for each channel is enabled (default).

Bit D5: If 0, use soft unmute on recovery from clock error. This is a slow recovery. Unmute takes same time as volume ramp defined in reg 0X0E.

If 1, use hard unmute on recovery from clock error (default). This is a fast recovery, a single step volume ramp

Bits D1–D0: Select de-emphasis

Table 6. System Control Register 1 (0x03)

D7	D6	D5	D4	D3	D2	D1	D0	FUNCTION
0	-	-	-	-	-	-	-	PWM high-pass (dc blocking) disabled
1	-	-	-	-	-	-	-	PWM high-pass (dc blocking) enabled ⁽¹⁾
-	0	-	-	-	-	-	-	Reserved ⁽¹⁾
-	-	0	-	-	-	-	-	Soft unmute on recovery from clock error
-	-	1	-	-	-	-	-	Hard unmute on recovery from clock error ⁽¹⁾
-	-	-	0	-	-	-	-	Reserved ⁽¹⁾
-	-	-	-	0	-	-	-	Reserved ⁽¹⁾
-	-	-	-	-	0	-	-	Reserved ⁽¹⁾
-	-	-	-	-	-	0	0	No de-emphasis ⁽¹⁾
-	-	-	-	-	-	0	1	Reserved
-	-	-	-	-	-	1	0	De-emphasis for $f_S = 44.1$ kHz
-	-	-	-	-	-	1	1	De-emphasis for $f_S = 48$ kHz

(1) Default values are in **bold**.

SERIAL DATA INTERFACE REGISTER (0x04)

As shown in [Table 7](#), the TAS5708 supports 9 serial data modes. The default is 24-bit, I²S mode,

Table 7. Serial Data Interface Control Register (0x04) Format

RECEIVE SERIAL DATA INTERFACE FORMAT	WORD LENGTH	D7–D4	D3	D2	D1	D0
Right-justified	16	0000	0	0	0	0
Right-justified	20	0000	0	0	0	1
Right-justified	24	0000	0	0	1	0
I ² S	16	000	0	0	1	1
I ² S	20	0000	0	1	0	0
I²S ⁽¹⁾	24	0000	0	1	0	1
Left-justified	16	0000	0	1	1	0
Left-justified	20	0000	0	1	1	1
Left-justified	24	0000	1	0	0	0
Reserved		0000	1	0	0	1
Reserved		0000	1	0	1	0
Reserved		0000	1	0	1	1
Reserved		0000	1	1	0	0
Reserved		0000	1	1	0	1
Reserved		0000	1	1	1	0
Reserved		0000	1	1	1	1

(1) Default values are in **bold**.

SYSTEM CONTROL REGISTER 2 (0x05)

When bit D6 is set low, the system exits all channel shutdown and starts playing audio; otherwise, the outputs are shut down (hard mute).

Table 8. System Control Register 2 (0x05)

D7	D6	D5	D4	D3	D2	D1	D0	FUNCTION
0	–	–	–	–	–	–	–	Reserved ⁽¹⁾
–	1	–	–	–	–	–	–	Enter all channel shut down (hard mute). ⁽¹⁾
–	0	–	–	–	–	–	–	Exit all channel shutdown (normal operation)
–	–	0	0	0	0	0	0	Reserved ⁽¹⁾

(1) Default values are in **bold**.

SOFT MUTE REGISTER (0x06)

Writing a 1 to any of the following bits sets the output of the respective channel to 50% duty cycle (soft mute).

Table 9. Soft Mute Register (0x06)

D7	D6	D5	D4	D3	D2	D1	D0	FUNCTION
–	–	–	–	–	–	–	1	Soft mute channel 1
–	–	–	–	–	–	–	0	Soft unmute channel 1
–	–	–	–	–	–	1	–	Soft mute channel 2
–	–	–	–	–	–	0	–	Soft unmute channel 2
0	0	0	0	0	0	–	–	Reserved

VOLUME REGISTERS (0x07, 0x08, 0x09)

Step size is 0.5 dB.

Master volume – 0x07 (default is mute)
 Channel-1 volume – 0x08 (default is 0 dB)
 Channel-2 volume – 0x09 (default is 0 dB)

Table 10. Volume Registers (0x07, 0x08, 0x09)

D 7	D 6	D 5	D 4	D 3	D 2	D 1	D 0	FUNCTION
0	0	0	0	0	0	0	0	24 dB
0	0	1	1	0	0	0	0	0 dB (default for individual channel volume) ⁽¹⁾
1	1	0	0	1	1	0	1	–78.5 dB
1	1	0	0	1	1	1	0	–79.0 dB
1	1	0	0	1	1	1	1	Values between 0xCF and 0xFE are Reserved
1	1	1	1	1	1	1	1	MUTE (default for master volume)

(1) Default values are in **bold**.

MASTER FINE VOLUME REGISTER (0x0A)

This register can be used to provide precision tuning of master volume.

Table 11. Master Fine Volume Register (0x0A)

D7	D6	D5	D4	D3	D2	D1	D0	FUNCTION
–	–	–	–	–	–	0	0	0 dB ⁽¹⁾
–	–	–	–	–	–	0	1	0.125 dB
–	–	–	–	–	–	1	0	0.25 dB
–	–	–	–	–	–	1	1	0.375 dB
1	–	–	–	–	–	–	–	Write enable bit
0	–	–	–	–	–	–	–	Ignore Write to register 0X0A

(1) Default values are in **bold**.

VOLUME CONFIGURATION REGISTER (0x0E)

Bits D2–D0: Volume slew rate (Used to control volume change and MUTE ramp rates). These bits control the number of steps in a volume ramp. Volume steps occur at a rate that depends on the sample rate of the I2S data as follows

Sample Rate (KHz)	Approximate Ramp Rate
8/16/32	125 us/step
11.025/22.05/44.1	90.7 us/step
12/24/48	83.3 us/step

Table 12. Volume Control Register (0x0E)

D7	D6	D5	D4	D3	D2	D1	D0	FUNCTION
1	0	0	1	0	–	–	–	Reserved ⁽¹⁾
–	–	–	–	–	0	0	0	Volume slew 512 steps (43 ms volume ramp time at 48kHz)
–	–	–	–	–	0	0	1	Volume slew 1024 steps (85 ms volume ramp time at 48kHz) ⁽¹⁾
–	–	–	–	–	0	1	0	Volume slew 2048 steps (171 ms volume ramp time at 48kHz)
–	–	–	–	–	0	1	1	Volume slew 256 steps (21ms volume ramp time at 48kHz)
–	–	–	–	–	1	X	X	Reserved

(1) Default values are in **bold**.

MODULATION LIMIT REGISTER (0x10)**Table 13. Modulation Limit Register (0x10)**

D7	D6	D5	D4	D3	D2	D1	D0	MODULATION LIMIT
–	–	–	–	–	0	0	0	99.2%
–	–	–	–	–	0	0	1	98.4%
–	–	–	–	–	0	1	0	97.7%
–	–	–	–	–	0	1	1	96.9%
–	–	–	–	–	1	0	0	96.1%
–	–	–	–	–	1	0	1	95.3%
–	–	–	–	–	1	1	0	94.5%
–	–	–	–	–	1	1	1	93.8%
0	0	0	0	0	–	–	–	RESERVED

INTERCHANNEL DELAY REGISTERS (0x11, 0x12, 0x13, and 0x14)

Internal PWM Channels 1, 2, $\bar{1}$, and $\bar{2}$ are mapped into registers 0x11, 0x12, 0x13, and 0x14.

Table 14. Channel Interchannel Delay Register Format

BITS DEFINITION	D7	D6	D5	D4	D3	D2	D1	D0	FUNCTION
	0	0	0	0	0	0	–	–	Minimum absolute delay, 0 DCLK cycles
	0	1	1	1	1	1	–	–	Maximum positive delay, 31 × 4 DCLK cycles
	1	0	0	0	0	0	–	–	Maximum negative delay, –32 × 4 DCLK cycles
							0	0	RESERVED
SUBADDRESS	D7	D6	D5	D4	D3	D2	D1	D0	Delay = (value) × 4 DCLKs
0x11	0	1	0	0	1	1	–	–	Default value for channel 1 ⁽¹⁾
0x12	0	1	1	1	0	0	–	–	Default value for channel 2 ⁽¹⁾
0x13	0	0	0	1	1	1	–	–	Default value for channel $\bar{1}$ ⁽¹⁾
0x14	0	1	1	0	0	1	–	–	Default value for channel $\bar{2}$ ⁽¹⁾

(1) Default values are in **bold**.

ICD settings have high impact on audio performance (eg: Dynamic Range, THD, Cross talk etc.) Therefore, appropriate ICD settings must be used. By default device has ICD settings for BD mode. If used in AD mode, then update these registers before coming out of all channel shutdown. Contact factory for AD Mode ICD settings.

MODE	BD MODE
0x11	4C
0x12	34
0x13	1C
0x14	64

START/STOP PERIOD REGISTER (0x1A)

This register is used to control the soft-start and soft-stop period following an enter/exit all channel shut down command or change in the $\overline{\text{PDN}}$ state. This helps reduce pops and clicks at start-up and shutdown. The times are only approximate and vary depending on device activity level and I2S clock stability.

Table 15. Start/Stop Period Register (0x1A)

D7	D6	D5	D4	D3	D2	D1	D0	FUNCTION
0	0	0	–	–	–	–	–	Reserved
–	–	–	0	0	–	–	–	No 50% duty cycle start/stop period
–	–	–	0	1	0	0	0	16.5-ms 50% duty cycle start/stop period
–	–	–	0	1	0	0	1	23.9-ms 50% duty cycle start/stop period
–	–	–	0	1	0	1	0	31.4-ms 50% duty cycle start/stop period ⁽¹⁾
–	–	–	0	1	0	1	1	40.4-ms 50% duty cycle start/stop period
–	–	–	0	1	1	0	0	53.9-ms 50% duty cycle start/stop period
–	–	–	0	1	1	0	1	70.3-ms 50% duty cycle start/stop period
–	–	–	0	1	1	1	0	94.2-ms 50% duty cycle start/stop period
–	–	–	0	1	1	1	1	125.7-ms 50% duty cycle start/stop period
–	–	–	1	0	0	0	0	164.6-ms 50% duty cycle start/stop period
–	–	–	1	0	0	0	1	239.4-ms 50% duty cycle start/stop period
–	–	–	1	0	0	1	0	314.2-ms 50% duty cycle start/stop period
–	–	–	1	0	0	1	1	403.9-ms 50% duty cycle start/stop period
–	–	–	1	0	1	0	0	538.6-ms 50% duty cycle start/stop period
–	–	–	1	0	1	0	1	703.1-ms 50% duty cycle start/stop period
–	–	–	1	0	1	1	0	942.5-ms 50% duty cycle start/stop period
–	–	–	1	0	1	1	1	1256.6-ms 50% duty cycle start/stop period
–	–	–	1	1	0	0	0	1728.1-ms 50% duty cycle start/stop period
–	–	–	1	1	0	0	1	2513.6-ms 50% duty cycle start/stop period
–	–	–	1	1	0	1	0	3299.1-ms 50% duty cycle start/stop period
–	–	–	1	1	0	1	1	4241.7-ms 50% duty cycle start/stop period
–	–	–	1	1	1	0	0	5655.6-ms 50% duty cycle start/stop period
–	–	–	1	1	1	0	1	7383.7-ms 50% duty cycle start/stop period
–	–	–	1	1	1	1	0	9897.3-ms 50% duty cycle start/stop period
–	–	–	1	1	1	1	1	13,196.4-ms 50% duty cycle start/stop period

(1) Default values are in **bold**.

OSCILLATOR TRIM REGISTER (0x1B)

The TAS5708 PWM processor contains an internal oscillator to support autodetect of I2S clock rates. This reduces system cost because an external reference is not required. Currently, TI recommends a reference resistor value of 18.2 k Ω (1%). This should be connected between OSC_RES and DVSSO.

Writing 0X00 to reg 0X1B enables the trim that was programmed at the factory.

Note that trim must always be run following reset of the device.

Table 16. Oscillator Trim Register (0x1B)

D7	D6	D5	D4	D3	D2	D1	D0	FUNCTION
1	–	–	–	–	–	–	–	Reserved ⁽¹⁾
–	0	–	–	–	–	–	–	Oscillator trim not done (read-only) ⁽¹⁾
–	1	–	–	–	–	–	–	Oscillator trim done (read only)
–	–	0	0	0	0	–	–	Reserved ⁽¹⁾
–	–	–	–	–	–	0	–	Select factory trim (Write a 0 to select factory trim; default is 1.)
–	–	–	–	–	–	1	–	Factory trim disabled ⁽¹⁾
–	–	–	–	–	–	–	0	Reserved ⁽¹⁾

(1) Default values are in **bold**.

BKND_ERR REGISTER (0x1C)

When a back-end error signal is received from the internal power stage, the power stage is reset stopping all PWM activity. Subsequently, the modulator waits approximately for the time listed in [Table 17](#) before attempting to re-start the power stage.

Table 17. BKND_ERR Register (0x1C)⁽¹⁾

D7	D6	D5	D4	D3	D2	D1	D0	FUNCTION
0	0	0	0	0	0	0	X	Reserved
–	–	–	–	0	0	1	0	Set back-end reset period to 299 ms ⁽²⁾
–	–	–	–	0	0	1	1	Set back-end reset period to 449 ms
–	–	–	–	0	1	0	0	Set back-end reset period to 598 ms
–	–	–	–	0	1	0	1	Set back-end reset period to 748 ms
–	–	–	–	0	1	1	0	Set back-end reset period to 898 ms
–	–	–	–	0	1	1	1	Set back-end reset period to 1047 ms
–	–	–	–	1	0	0	0	Set back-end reset period to 1197 ms
–	–	–	–	1	0	0	1	Set back-end reset period to 1346 ms
–	–	–	–	1	0	1	X	Set back-end reset period to 1496 ms
–	–	–	–	1	1	X	X	Set back-end reset period to 1496 ms

(1) This register can be written only with a "non-Reserved" value. Also this register can be written once after the reset.

(2) Default values are in **bold**.

INPUT MULTIPLEXER REGISTER (0x20)

This register controls the modulation scheme (AD or BD mode) as well as the routing of I2S audio to the internal channels.

Table 18. Input Multiplexer Register (0x20)

D31	D30	D29	D28	D27	D26	D25	D24	FUNCTION
0	0	0	0	0	0	0	0	Reserved ⁽¹⁾
D23	D22	D21	D20	D19	D18	D17	D16	FUNCTION
0	–	–	–	–	–	–	–	Channel-1 AD Mode
1	–	–	–	–	–	–	–	Channel-1 BD mode⁽¹⁾
–	0	0	0	–	–	–	–	SDIN-L to channel 1 ⁽¹⁾
–	0	0	1	–	–	–	–	SDIN-R to channel 1
–	0	1	0	–	–	–	–	Reserved
–	0	1	1	–	–	–	–	Reserved
–	1	0	0	–	–	–	–	Reserved
–	1	0	1	–	–	–	–	Reserved
–	1	1	0	–	–	–	–	Ground (0) to channel 1
–	1	1	1	–	–	–	–	Reserved
–	–	–	–	0	–	–	–	Channel 2 AD mode
–	–	–	–	1	–	–	–	Channel 2 BD mode⁽¹⁾
–	–	–	–	–	0	0	0	SDIN-L to channel 2
–	–	–	–	–	0	0	1	SDIN-R to channel 2 ⁽¹⁾
–	–	–	–	–	0	1	0	Reserved
–	–	–	–	–	0	1	1	Reserved
–	–	–	–	–	1	0	0	Reserved
–	–	–	–	–	1	0	1	Reserved
–	–	–	–	–	1	1	0	Ground (0) to channel 2
–	–	–	–	–	1	1	1	Reserved
D15	D14	D13	D12	D11	D10	D9	D8	FUNCTION
0	1	1	1	0	1	1	1	Reserved ⁽¹⁾
D7	D6	D5	D4	D3	D2	D1	D0	FUNCTION
0	1	1	1	1	0	1	0	Reserved ⁽¹⁾

(1) Default values are in **bold**.

PWM OUTPUT MUX REGISTER (0x25)

This DAP output mux selects which internal PWM channel is output to the external pins. Any channel can be output to any external output pin.

Bits D21–D20: Selects which PWM channel is output to OUT_A

Bits D17–D16: Selects which PWM channel is output to OUT_B

Bits D13–D12: Selects which PWM channel is output to OUT_C

Bits D09–D08: Selects which PWM channel is output to OUT_D

Note that channels are enclosed so that channel 1 = 0x00, channel 2 = 0x01, channel 1 = 0x02, and channel 2 = 0x03.

Table 19. PWM Output Mux Register (0x25)

D31	D30	D29	D28	D27	D26	D25	D24	FUNCTION
0	0	0	0	0	0	0	1	Reserved ⁽¹⁾
D23	D22	D21	D20	D19	D18	D17	D16	FUNCTION
0	0	–	–	–	–	–	–	Reserved ⁽¹⁾
–	–	0	0	–	–	–	–	Multiplex channel 1 to OUT_A ⁽¹⁾
–	–	0	1	–	–	–	–	Multiplex channel 2 to OUT_A
–	–	1	0	–	–	–	–	Multiplex channel 1 to OUT_A
–	–	1	1	–	–	–	–	Multiplex channel 2 to OUT_A
–	–	–	–	0	0	–	–	Reserved ⁽¹⁾
–	–	–	–	–	–	0	0	Multiplex channel 1 to OUT_B
–	–	–	–	–	–	0	1	Multiplex channel 2 to OUT_B
–	–	–	–	–	–	1	0	Multiplex channel 1 to OUT_B ⁽¹⁾
–	–	–	–	–	–	1	1	Multiplex channel 2 to OUT_B
D15	D14	D13	D12	D11	D10	D9	D8	FUNCTION
0	0	–	–	–	–	–	–	Reserved ⁽¹⁾
–	–	0	0	–	–	–	–	Multiplex channel 1 to OUT_C
–	–	0	1	–	–	–	–	Multiplex channel 2 to OUT_C ⁽¹⁾
–	–	1	0	–	–	–	–	Multiplex channel 1 to OUT_C
–	–	1	1	–	–	–	–	Multiplex channel 2 to OUT_C
–	–	–	–	0	0	–	–	Reserved ⁽¹⁾
–	–	–	–	–	–	0	0	Multiplex channel 1 to OUT_D
–	–	–	–	–	–	0	1	Multiplex channel 2 to OUT_D
–	–	–	–	–	–	1	0	Multiplex channel 1 to OUT_D
–	–	–	–	–	–	1	1	Multiplex channel 2 to OUT_D ⁽¹⁾
D7	D6	D5	D4	D3	D2	D1	D0	FUNCTION
0	1	0	0	0	1	0	1	RESERVED

(1) Default values are in **bold**.**DRC CONTROL (0x46)**

D31	D30	D29	D28	D27	D26	D25	D24	FUNCTION
0	0	0	0	0	0	0	0	Reserved ⁽¹⁾
D23	D22	D21	D20	D19	D18	D17	D16	FUNCTION
0	0	0	0	0	0	0	0	Reserved ⁽¹⁾
D15	D14	D13	D12	D11	D10	D9	D8	FUNCTION
0	0	0	0	0	0	0	0	Reserved ⁽¹⁾
D7	D6	D5	D4	D3	D2	D1	D0	FUNCTION
–	–	–	–	–	–	–	0	DRC turned OFF ⁽¹⁾
–	–	–	–	–	–	–	1	DRC turned ON
0	0	0	0	0	0	0	–	Reserved ⁽¹⁾

(1) Default values are in **bold**.

BANK SWITCH AND EQ CONTROL (0x50)
Table 20. Bank Switching Command

D31	D30	D29	D28	D27	D26	D25	D24	FUNCTION
0	–	–	–	–	–	–	–	32 kHz, does not use bank 3 ⁽¹⁾
1	–	–	–	–	–	–	–	32 kHz, uses bank 3
–	0	–	–	–	–	–	–	Reserved
–	–	0	–	–	–	–	–	Reserved
–	–	–	0	–	–	–	–	44.1/48 kHz, does not use bank 3 ⁽¹⁾
–	–	–	1	–	–	–	–	44.1/48 kHz, uses bank 3
–	–	–	–	0	–	–	–	16 kHz, does not use bank 3
–	–	–	–	1	–	–	–	16 kHz, uses bank 3 ⁽¹⁾
–	–	–	–	–	0	–	–	22.025/24 kHz, does not use bank 3
–	–	–	–	–	1	–	–	22.025/24 kHz, uses bank 3 ⁽¹⁾
–	–	–	–	–	–	0	–	8 kHz, does not use bank 3
–	–	–	–	–	–	1	–	8 kHz, uses bank 3 ⁽¹⁾
–	–	–	–	–	–	–	0	11.025 kHz/12, does not use bank 3
–	–	–	–	–	–	–	1	11.025/12 kHz, uses bank 3 ⁽¹⁾
D23	D22	D21	D20	D19	D18	D17	D16	FUNCTION
0	–	–	–	–	–	–	–	32 kHz, does not use bank 2 ⁽¹⁾
1	–	–	–	–	–	–	–	32 kHz, uses bank 2
–	1	–	–	–	–	–	–	Reserved ⁽¹⁾
–	–	1	–	–	–	–	–	Reserved ⁽¹⁾
–	–	–	0	–	–	–	–	44.1/48 kHz, does not use bank 2
–	–	–	1	–	–	–	–	44.1/48 kHz, uses bank 2 ⁽¹⁾
–	–	–	–	0	–	–	–	16 kHz, does not use bank 2 ⁽¹⁾
–	–	–	–	1	–	–	–	16 kHz, uses bank 2
–	–	–	–	–	0	–	–	22.025/24 kHz, does not use bank 2 ⁽¹⁾
–	–	–	–	–	1	–	–	22.025/24 kHz, uses bank 2
–	–	–	–	–	–	0	–	8 kHz, does not use bank 2 ⁽¹⁾
–	–	–	–	–	–	1	–	8 kHz, uses bank 2
–	–	–	–	–	–	–	0	11.025/12 kHz, does not use bank 2 ⁽¹⁾
–	–	–	–	–	–	–	1	11.025/12 kHz, uses bank 2
D15	D14	D13	D12	D11	D10	D9	D8	FUNCTION
0	–	–	–	–	–	–	–	32 kHz, does not use bank 1
1	–	–	–	–	–	–	–	32 kHz, uses bank 1 ⁽¹⁾
–	0	–	–	–	–	–	–	Reserved
–	–	0	–	–	–	–	–	Reserved
–	–	–	0	–	–	–	–	44.1/48 kHz, does not use bank 1 ⁽¹⁾
–	–	–	1	–	–	–	–	44.1/48 kHz, uses bank 1
–	–	–	–	0	–	–	–	16 kHz, does not use bank 1 ⁽¹⁾
–	–	–	–	1	–	–	–	16 kHz, uses bank 1
–	–	–	–	–	0	–	–	22.025/24 kHz, does not use bank 1 ⁽¹⁾
–	–	–	–	–	1	–	–	22.025/24 kHz, uses bank 1
–	–	–	–	–	–	0	–	8 kHz, does not use bank 1 ⁽¹⁾
–	–	–	–	–	–	1	–	8 kHz, uses bank 1
–	–	–	–	–	–	–	0	11.025/12 kHz, does not use bank 1 ⁽¹⁾
–	–	–	–	–	–	–	1	11.025/12 kHz, uses bank 1

(1) Default values are in **bold**.

Table 20. Bank Switching Command (continued)

D7	D6	D5	D4	D3	D2	D1	D0	FUNCTION
0								EQ ON
1	–	–	–	–	–	–	–	EQ OFF (bypass BQ 0-6 of channels 1 and 2)
–	0	–	–	–	–	–	–	Reserved ⁽²⁾
–	–	0	–	–	–	–	–	Ignore bank-mapping in bits D31–D8. Use default mapping. ⁽²⁾
		1						Use bank-mapping in bits D31–D8.
–	–	–	0	–	–	–	–	L and R can be written independently. ⁽²⁾
–	–	–	1	–	–	–	–	L and R are ganged for EQ biquads; a write to Left channel BQ is also written to Right channel BQ. (0X29-2F is ganged to 0X30-0X36).
–	–	–	–	0	–	–	–	Reserved ⁽²⁾
–	–	–	–	–	0	0	0	No bank switching. All updates to DAP ⁽²⁾
–	–	–	–	–	0	0	1	Configure bank 1 (32 kHz by default)
–	–	–	–	–	0	1	0	Configure bank 2 (44.1/48 kHz by default)
–	–	–	–	–	0	1	1	Configure bank 3 (other sample rates by default)
–	–	–	–	–	1	0	0	Automatic bank selection
–	–	–	–	–	1	0	1	Reserved
–	–	–	–	–	1	1	X	Reserved

(2) Default values are in **bold**.

PACKAGING INFORMATION

Orderable Device	Status (1)	Package Type	Package Drawing	Pins	Package Qty	Eco Plan (2)	Lead/Ball Finish	MSL Peak Temp (3)	Op Temp (°C)	Top-Side Markings (4)	Samples
TAS5708PHP	ACTIVE	HTQFP	PHP	48	250	Green (RoHS & no Sb/Br)	CU NIPDAU	Level-3-260C-168 HR	0 to 85	TAS5708	Samples
TAS5708PHPR	ACTIVE	HTQFP	PHP	48	1000	Green (RoHS & no Sb/Br)	CU NIPDAU	Level-3-260C-168 HR	0 to 85	TAS5708	Samples

(1) The marketing status values are defined as follows:

ACTIVE: Product device recommended for new designs.

LIFEBUY: TI has announced that the device will be discontinued, and a lifetime-buy period is in effect.

NRND: Not recommended for new designs. Device is in production to support existing customers, but TI does not recommend using this part in a new design.

PREVIEW: Device has been announced but is not in production. Samples may or may not be available.

OBSOLETE: TI has discontinued the production of the device.

(2) Eco Plan - The planned eco-friendly classification: Pb-Free (RoHS), Pb-Free (RoHS Exempt), or Green (RoHS & no Sb/Br) - please check <http://www.ti.com/productcontent> for the latest availability information and additional product content details.

TBD: The Pb-Free/Green conversion plan has not been defined.

Pb-Free (RoHS): TI's terms "Lead-Free" or "Pb-Free" mean semiconductor products that are compatible with the current RoHS requirements for all 6 substances, including the requirement that lead not exceed 0.1% by weight in homogeneous materials. Where designed to be soldered at high temperatures, TI Pb-Free products are suitable for use in specified lead-free processes.

Pb-Free (RoHS Exempt): This component has a RoHS exemption for either 1) lead-based flip-chip solder bumps used between the die and package, or 2) lead-based die adhesive used between the die and leadframe. The component is otherwise considered Pb-Free (RoHS compatible) as defined above.

Green (RoHS & no Sb/Br): TI defines "Green" to mean Pb-Free (RoHS compatible), and free of Bromine (Br) and Antimony (Sb) based flame retardants (Br or Sb do not exceed 0.1% by weight in homogeneous material)

(3) MSL, Peak Temp. -- The Moisture Sensitivity Level rating according to the JEDEC industry standard classifications, and peak solder temperature.

(4) Multiple Top-Side Markings will be inside parentheses. Only one Top-Side Marking contained in parentheses and separated by a "~" will appear on a device. If a line is indented then it is a continuation of the previous line and the two combined represent the entire Top-Side Marking for that device.

Important Information and Disclaimer: The information provided on this page represents TI's knowledge and belief as of the date that it is provided. TI bases its knowledge and belief on information provided by third parties, and makes no representation or warranty as to the accuracy of such information. Efforts are underway to better integrate information from third parties. TI has taken and continues to take reasonable steps to provide representative and accurate information but may not have conducted destructive testing or chemical analysis on incoming materials and chemicals. TI and TI suppliers consider certain information to be proprietary, and thus CAS numbers and other limited information may not be available for release.

In no event shall TI's liability arising out of such information exceed the total purchase price of the TI part(s) at issue in this document sold by TI to Customer on an annual basis.

TAPE AND REEL INFORMATION

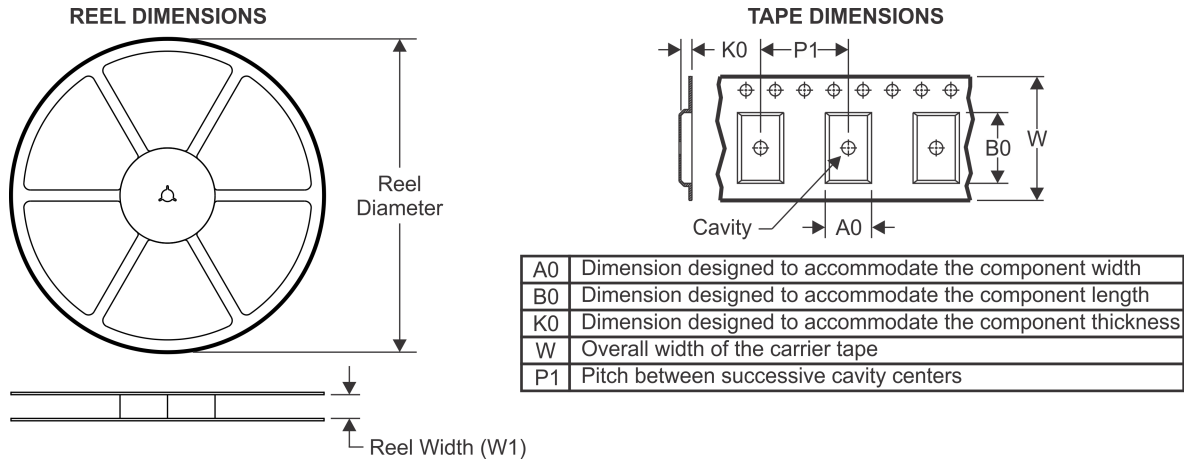

QUADRANT ASSIGNMENTS FOR PIN 1 ORIENTATION IN TAPE



*All dimensions are nominal

Device	Package Type	Package Drawing	Pins	SPQ	Reel Diameter (mm)	Reel Width W1 (mm)	A0 (mm)	B0 (mm)	K0 (mm)	P1 (mm)	W (mm)	Pin1 Quadrant
TAS5708PHPR	HTQFP	PHP	48	1000	330.0	16.4	9.6	9.6	1.5	12.0	16.0	Q2
TAS5708PHPR	HTQFP	PHP	48	1000	330.0	16.4	9.6	9.6	1.5	12.0	16.0	Q2

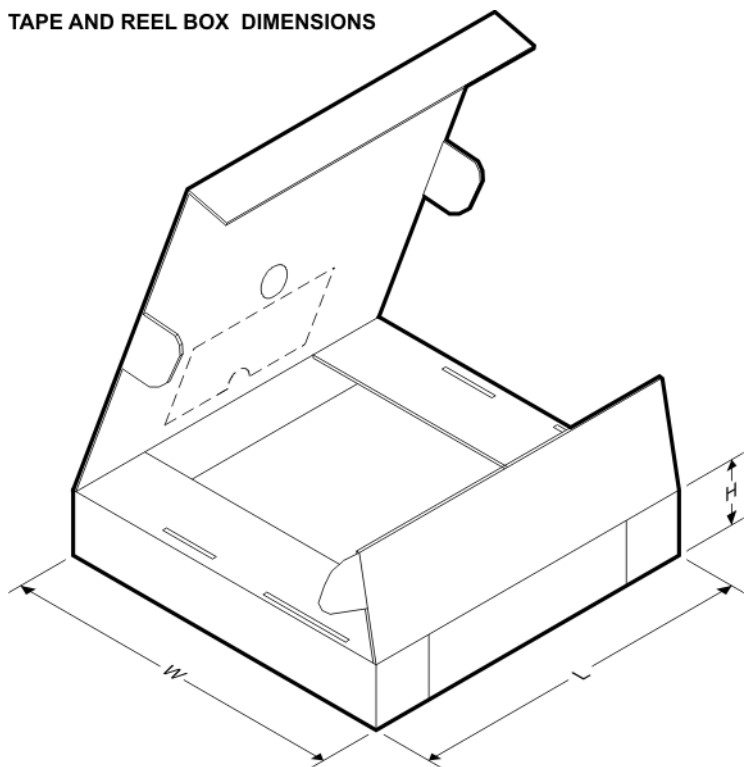
TAPE AND REEL BOX DIMENSIONS

*All dimensions are nominal

Device	Package Type	Package Drawing	Pins	SPQ	Length (mm)	Width (mm)	Height (mm)
TAS5708PHPR	HTQFP	PHP	48	1000	336.6	336.6	31.8
TAS5708PHPR	HTQFP	PHP	48	1000	367.0	367.0	38.0

PHP (S-PQFP-G48)

PowerPAD™ PLASTIC QUAD FLATPACK

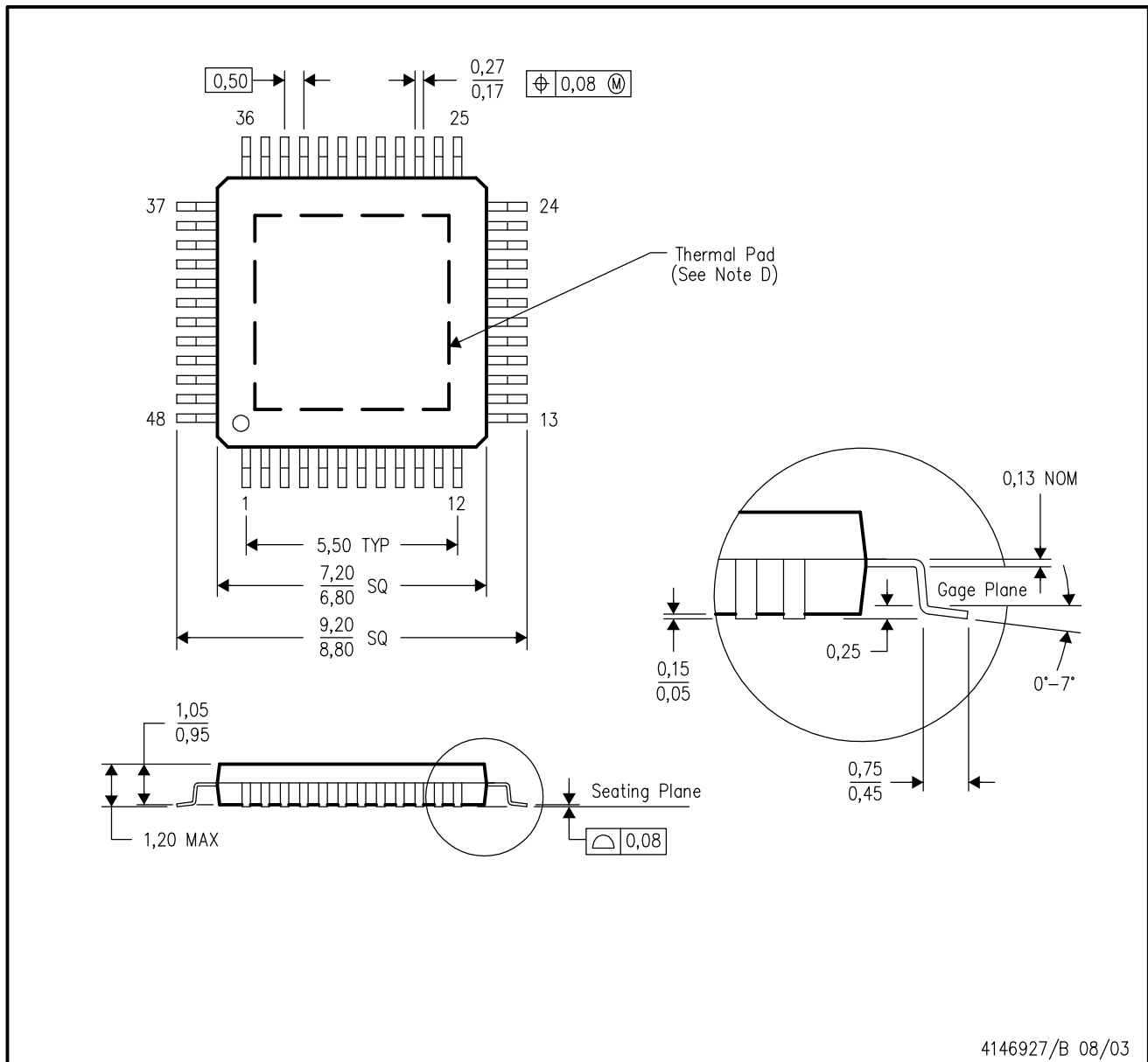

- NOTES:
- A. All linear dimensions are in millimeters.
 - B. This drawing is subject to change without notice.
 - C. Body dimensions do not include mold flash or protrusion
 - D. This package is designed to be soldered to a thermal pad on the board. Refer to Technical Brief, PowerPad Thermally Enhanced Package, Texas Instruments Literature No. SLMA002 for information regarding recommended board layout. This document is available at www.ti.com <<http://www.ti.com>>.
 - E. Falls within JEDEC MS-026

PowerPAD is a trademark of Texas Instruments.

THERMAL PAD MECHANICAL DATA

PHP (S-PQFP-G48)

PowerPAD™ PLASTIC QUAD FLATPACK

THERMAL INFORMATION

This PowerPAD™ package incorporates an exposed thermal pad that is designed to be attached to a printed circuit board (PCB). The thermal pad must be soldered directly to the PCB. After soldering, the PCB can be used as a heatsink. In addition, through the use of thermal vias, the thermal pad can be attached directly to the appropriate copper plane shown in the electrical schematic for the device, or alternatively, can be attached to a special heatsink structure designed into the PCB. This design optimizes the heat transfer from the integrated circuit (IC).

For additional information on the PowerPAD package and how to take advantage of its heat dissipating abilities, refer to Technical Brief, PowerPAD Thermally Enhanced Package, Texas Instruments Literature No. SLMA002 and Application Brief, PowerPAD Made Easy, Texas Instruments Literature No. SLMA004. Both documents are available at www.ti.com.

The exposed thermal pad dimensions for this package are shown in the following illustration.

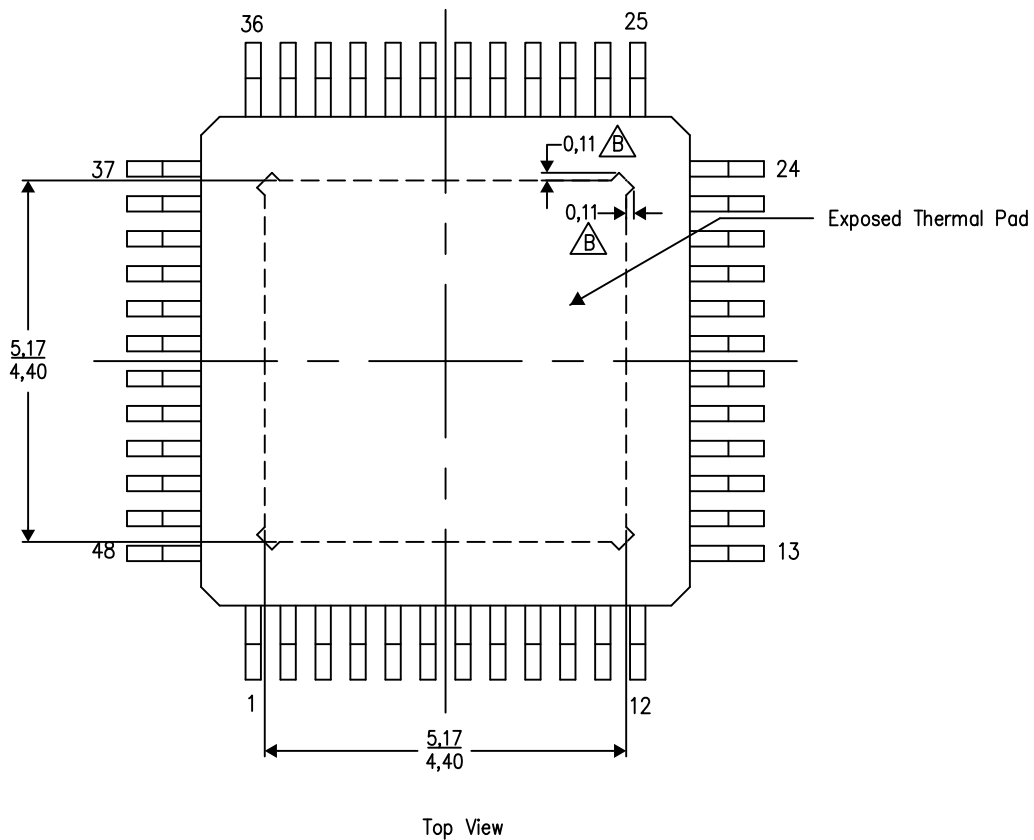

Exposed Thermal Pad Dimensions

4206329-7/N 04/12

NOTE: A. All linear dimensions are in millimeters

 Tie strap features may not be present.

PowerPAD is a trademark of Texas Instruments

IMPORTANT NOTICE

Texas Instruments Incorporated and its subsidiaries (TI) reserve the right to make corrections, enhancements, improvements and other changes to its semiconductor products and services per JESD46, latest issue, and to discontinue any product or service per JESD48, latest issue. Buyers should obtain the latest relevant information before placing orders and should verify that such information is current and complete. All semiconductor products (also referred to herein as "components") are sold subject to TI's terms and conditions of sale supplied at the time of order acknowledgment.

TI warrants performance of its components to the specifications applicable at the time of sale, in accordance with the warranty in TI's terms and conditions of sale of semiconductor products. Testing and other quality control techniques are used to the extent TI deems necessary to support this warranty. Except where mandated by applicable law, testing of all parameters of each component is not necessarily performed.

TI assumes no liability for applications assistance or the design of Buyers' products. Buyers are responsible for their products and applications using TI components. To minimize the risks associated with Buyers' products and applications, Buyers should provide adequate design and operating safeguards.

TI does not warrant or represent that any license, either express or implied, is granted under any patent right, copyright, mask work right, or other intellectual property right relating to any combination, machine, or process in which TI components or services are used. Information published by TI regarding third-party products or services does not constitute a license to use such products or services or a warranty or endorsement thereof. Use of such information may require a license from a third party under the patents or other intellectual property of the third party, or a license from TI under the patents or other intellectual property of TI.

Reproduction of significant portions of TI information in TI data books or data sheets is permissible only if reproduction is without alteration and is accompanied by all associated warranties, conditions, limitations, and notices. TI is not responsible or liable for such altered documentation. Information of third parties may be subject to additional restrictions.

Resale of TI components or services with statements different from or beyond the parameters stated by TI for that component or service voids all express and any implied warranties for the associated TI component or service and is an unfair and deceptive business practice. TI is not responsible or liable for any such statements.

Buyer acknowledges and agrees that it is solely responsible for compliance with all legal, regulatory and safety-related requirements concerning its products, and any use of TI components in its applications, notwithstanding any applications-related information or support that may be provided by TI. Buyer represents and agrees that it has all the necessary expertise to create and implement safeguards which anticipate dangerous consequences of failures, monitor failures and their consequences, lessen the likelihood of failures that might cause harm and take appropriate remedial actions. Buyer will fully indemnify TI and its representatives against any damages arising out of the use of any TI components in safety-critical applications.

In some cases, TI components may be promoted specifically to facilitate safety-related applications. With such components, TI's goal is to help enable customers to design and create their own end-product solutions that meet applicable functional safety standards and requirements. Nonetheless, such components are subject to these terms.

No TI components are authorized for use in FDA Class III (or similar life-critical medical equipment) unless authorized officers of the parties have executed a special agreement specifically governing such use.

Only those TI components which TI has specifically designated as military grade or "enhanced plastic" are designed and intended for use in military/aerospace applications or environments. Buyer acknowledges and agrees that any military or aerospace use of TI components which have **not** been so designated is solely at the Buyer's risk, and that Buyer is solely responsible for compliance with all legal and regulatory requirements in connection with such use.

TI has specifically designated certain components as meeting ISO/TS16949 requirements, mainly for automotive use. In any case of use of non-designated products, TI will not be responsible for any failure to meet ISO/TS16949.

Products

Audio	www.ti.com/audio
Amplifiers	amplifier.ti.com
Data Converters	dataconverter.ti.com
DLP® Products	www.dlp.com
DSP	dsp.ti.com
Clocks and Timers	www.ti.com/clocks
Interface	interface.ti.com
Logic	logic.ti.com
Power Mgmt	power.ti.com
Microcontrollers	microcontroller.ti.com
RFID	www.ti-rfid.com
OMAP Applications Processors	www.ti.com/omap
Wireless Connectivity	www.ti.com/wirelessconnectivity

Applications

Automotive and Transportation	www.ti.com/automotive
Communications and Telecom	www.ti.com/communications
Computers and Peripherals	www.ti.com/computers
Consumer Electronics	www.ti.com/consumer-apps
Energy and Lighting	www.ti.com/energy
Industrial	www.ti.com/industrial
Medical	www.ti.com/medical
Security	www.ti.com/security
Space, Avionics and Defense	www.ti.com/space-avionics-defense
Video and Imaging	www.ti.com/video

TI E2E Community

e2e.ti.com