



# STW15NK90Z

N-channel 900V - 0.40Ω - 15A - TO-247  
Zener - Protected SuperMESH™ PowerMOSFET

## General features

Type	V <sub>DSS</sub> (@T <sub>Jmax</sub> )	R <sub>DS(on)</sub>	I <sub>D</sub>	P <sub>W</sub>
STW15NK90Z	900 V	< 0.55 Ω	15 A	350W

- Extremely high dv/dt capability
- 100% avalanche tested
- Gate charge minimized
- Very low intrinsic capacitances
- Very good manufacturing repeatability

## Description

The SuperMESH™ series is obtained through an extreme optimization of ST's well established strip-based PowerMESH™ layout. In addition to pushing on-resistance significantly down, special care is taken to ensure a very good dv/dt capability for the most demanding applications. Such series complements ST full range of high voltage MOSFETs including revolutionary MDmesh™ products.

## Applications

- Switching application

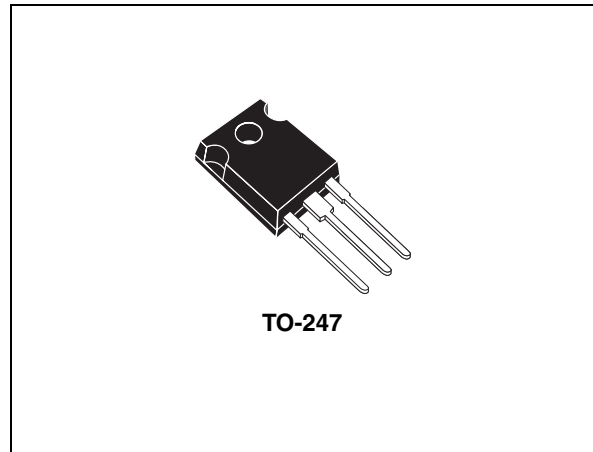

## Internal schematic diagram

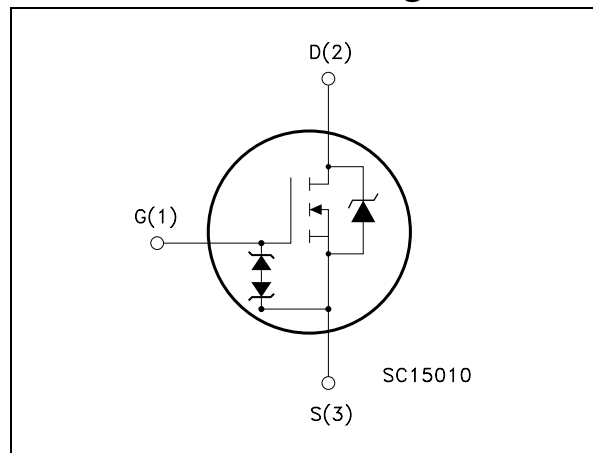

## Order codes

Part number	Marking	Package	Packaging
STW15NK90Z	W15NK90Z	TO-247	Tube

## Contents

<b>1</b>	<b>Electrical ratings</b> .....	<b>3</b>
1.1	Protection features of gate-to-source zener diodes .....	4
<b>2</b>	<b>Electrical characteristics</b> .....	<b>5</b>
2.1	Electrical characteristics (curves) .....	7
<b>3</b>	<b>Test circuit Package mechanical data</b> .....	<b>10</b>
<b>4</b>	<b>Package mechanical data</b> .....	<b>11</b>
<b>5</b>	<b>Revision history</b> .....	<b>13</b>

# 1 Electrical ratings

**Table 1. Absolute maximum ratings**

Symbol	Parameter	Value	Unit
$V_{DS}$	Drain-source voltage ( $V_{GS} = 0$ )	900	V
$V_{DGR}$	Drain-gate voltage ( $R_{GS} = 20K\Omega$ )	900	V
$V_{GS}$	Gate-source voltage	$\pm 30$	V
$I_D$	Drain current (continuous) at $T_C = 25^\circ C$	15	A
$I_D$	Drain current (continuous) at $T_C = 100^\circ C$	9.5	A
$I_{DM}^{(1)}$	Drain current (pulsed)	60	A
$P_{TOT}$	Total dissipation at $T_C = 25^\circ C$	350	W
	Derating Factor	2.77	W/ $^\circ C$
$V_{ESD (G-S)}$	Gate source ESD(HBM-C=100pF, R=1,5K $\Omega$ )	6000	V
$dv/dt^{(2)}$	Peak diode recovery voltage slope	4.5	V/ns
$T_J$ $T_{stg}$	Operating junction temperature Storage temperature	-55 to 150	$^\circ C$

1. Pulse width limited by safe operating area

2.  $I_{SD} \leq 15 A$ ,  $di/dt \leq 200 A/\mu s$ ,  $V_{DD} \leq 900 V$ ,  $T_J \leq T_{JMAX}$

**Table 2. Thermal data**

Symbol	Parameter	Value	Unit
$R_{thj-case}$	Thermal resistance junction-case Max	0.36	$^\circ C/W$
$R_{thj-a}$	Thermal resistance junction-ambient Max	50	$^\circ C/W$
$T_l$	Maximum lead temperature for soldering purpose	300	$^\circ C$

**Table 3. Avalanche characteristics**

Symbol	Parameter	Value	Unit
$I_{AR}$	Avalanche current, repetitive or not-repetitive (pulse width limited by $T_J$ Max)	15	A
$E_{AS}$	Single pulse avalanche energy (starting $T_J = 25^\circ C$ , $I_d = I_{AR}$ , $V_{dd} = 50V$ )	360	mJ

**Table 4. Gate-source zener diode**

Symbol	Parameter	Test conditions	Min.	Typ.	Max.	Unit
$BV_{GSO}$	Gate-source breakdown voltage	$I_{gs}=\pm 1\text{mA}$ (Open Drain)	30			V

## 1.1 Protection features of gate-to-source zener diodes

The built-in back-to-back Zener diodes have specifically been designed to enhance not only the device's ESD capability, but also to make them safely absorb possible voltage transients that may occasionally be applied from gate to source. In this respect the Zener voltage is appropriate to achieve an efficient and cost-effective intervention to protect the device's integrity. These integrated Zener diodes thus avoid the usage of external components.

## 2 Electrical characteristics

( $T_{CASE}=25^{\circ}C$  unless otherwise specified)

**Table 5. On/off states**

Symbol	Parameter	Test conditions	Min.	Typ.	Max.	Unit
$V_{(BR)DSS}$	Drain-source breakdown voltage	$I_D = 1mA, V_{GS} = 0$	900			V
$I_{DSS}$	Zero gate voltage drain current ( $V_{GS} = 0$ )	$V_{DS} = \text{Max rating},$ $V_{DS} = \text{Max rating},$ $T_c = 125^{\circ}C$			1 50	$\mu A$ $\mu A$
$I_{GSS}$	Gate body leakage current ( $V_{GS} = 0$ )	$V_{GS} = \pm 20V$			$\pm 10$	$\mu A$
$V_{GS(th)}$	Gate threshold voltage	$V_{DS} = V_{GS}, I_D = 150 \mu A$	3	3.75	4.5	V
$R_{DS(on)}$	Static drain-source on resistance	$V_{GS} = 10V, I_D = 7.5 A$		0.40	0.55	$\Omega$

**Table 6. Dynamic**

Symbol	Parameter	Test conditions	Min.	Typ.	Max.	Unit
$g_{fs}^{(1)}$	Forward transconductance	$V_{DS} = 15V, I_D = 7.5 A$		15		S
$C_{iss}$	Input capacitance	$V_{DS} = 25V, f = 1 \text{ MHz}, V_{GS} = 0$		6100		pF
$C_{oss}$	Output capacitance			465		pF
$C_{rss}$	Reverse transfer capacitance			96		pF
$C_{osseq}^{(2)}$	Equivalent output capacitance	$V_{GS} = 0, V_{DS} = 0V \text{ to } 720V$		230		pF
$t_{d(on)}$	Turn-on delay time	$V_{DD} = 450V, I_D = 7.5A,$ $R_G = 4.7\Omega, V_{GS} = 10V$ (see <a href="#">Figure 16</a> )		42		ns
$t_r$	Rise time			27		ns
$t_{d(off)}$	Off-voltage rise time			135		ns
$t_f$	Fall time			35		ns
$Q_g$	Total gate charge	$V_{DD} = 720V, I_D = 15A$ $V_{GS} = 10V$		190	256	nC
$Q_{gs}$	Gate-source charge			56		nC
$Q_{gd}$	Gate-drain charge			70		nC

1. Pulsed: pulse duration=300 $\mu s$ , duty cycle 1.5%

2.  $C_{oss eq.}$  is defined as a constant equivalent capacitance giving the same charging time as  $C_{oss}$  when  $V_{DS}$  increases from 0 to 80%  $V_{DSS}$

**Table 7. Source drain diode**

Symbol	Parameter	Test conditions	Min	Typ.	Max	Unit
$I_{SD}$	Source-drain current				15	A
$I_{SDM}^{(1)}$	Source-drain current (pulsed)				60	A
$V_{SD}^{(2)}$	Forward on voltage	$I_{SD}=15A, V_{GS}=0$			1.6	V
$t_{rr}$ $Q_{rr}$ $I_{RRM}$	Reverse recovery time Reverse recovery charge Reverse recovery current	$I_{SD}=15 A,$ $di/dt = 100A/\mu s,$ $V_{DD}=100 V, T_j=25^\circ C$ (see <a href="#">Figure 18</a> )		748 10.5 28		ns $\mu C$ A
$t_{rr}$ $Q_{rr}$ $I_{RRM}$	Reverse recovery time Reverse recovery charge Reverse recovery current	$I_{SD}=15 A,$ $di/dt = 100A/\mu s,$ $V_{DD}=100V, T_j=150^\circ C$ (see <a href="#">Figure 18</a> )		900 13 28.5		ns $\mu C$ A

1. Pulse width limited by safe operating area
2. Pulsed: pulse duration=300 $\mu s$ , duty cycle 1.5%

## 2.1 Electrical characteristics (curves)

Figure 1. Safe operating area

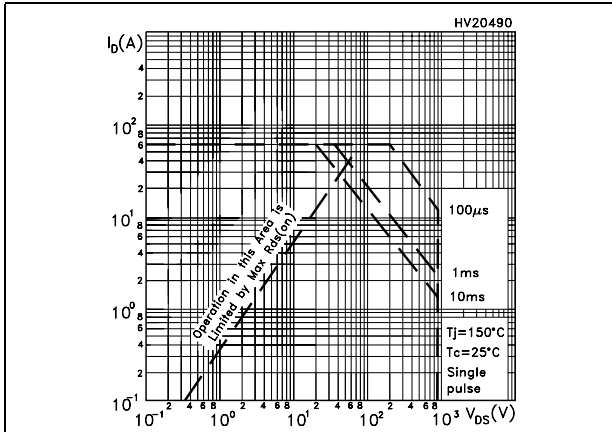

Figure 2. Thermal impedance

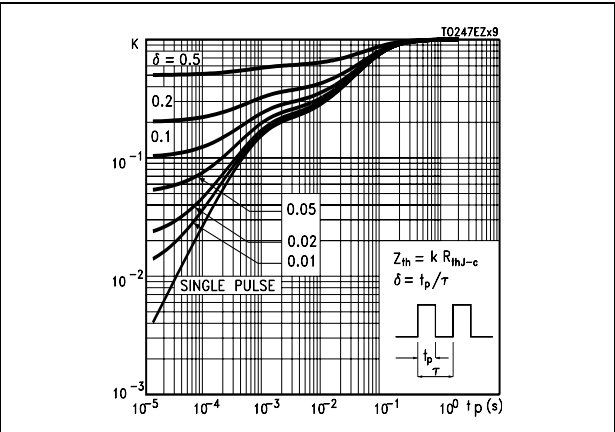

Figure 3. Output characteristics

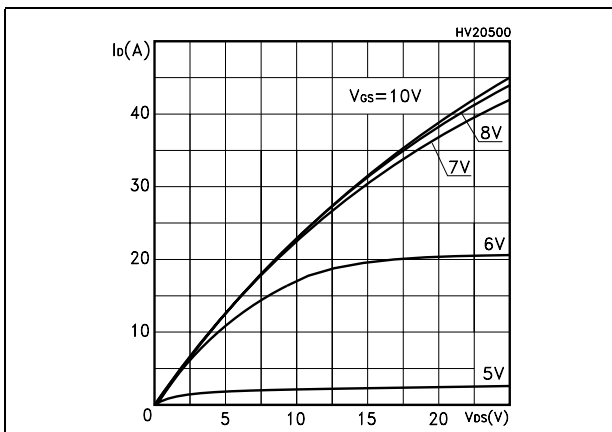

Figure 4. Transfer characteristics

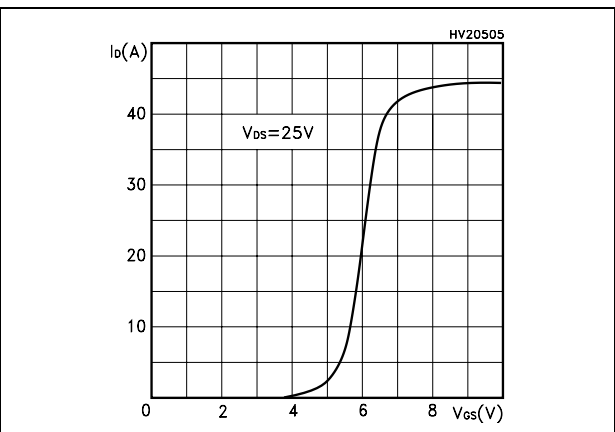

Figure 5. Transconductance

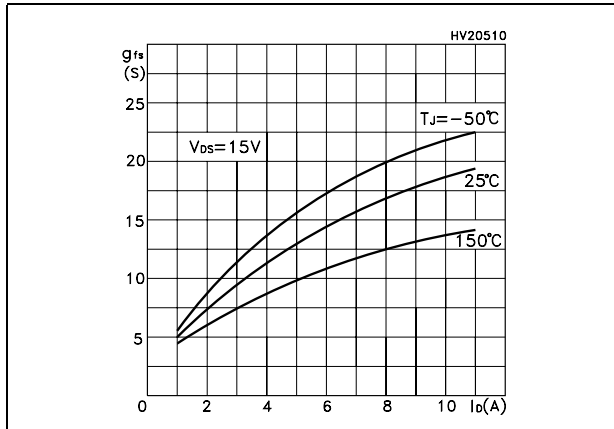

Figure 6. Static drain-source on resistance

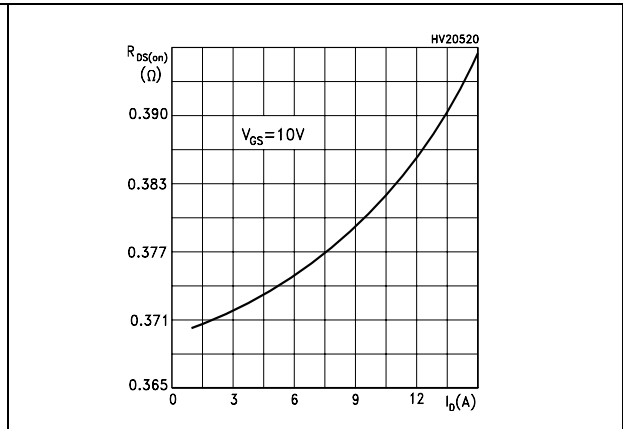

Figure 7. Gate charge vs gate-source voltage Figure 8. Capacitance variations

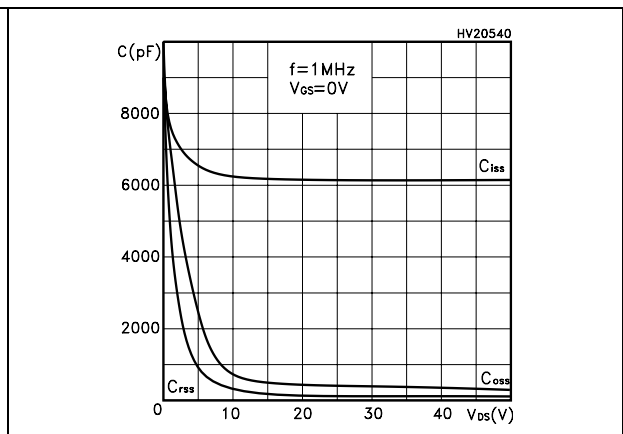
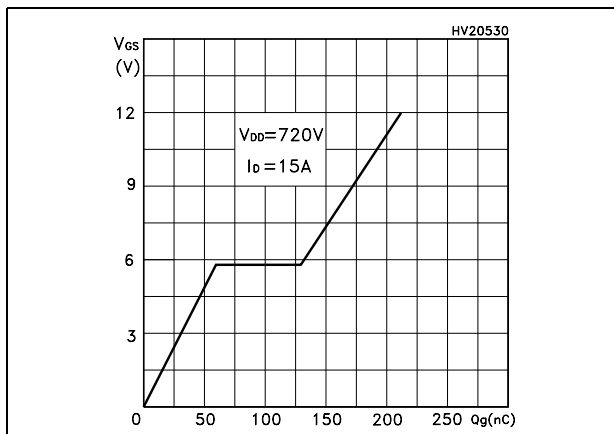

Figure 9. Normalized gate threshold voltage vs temperature

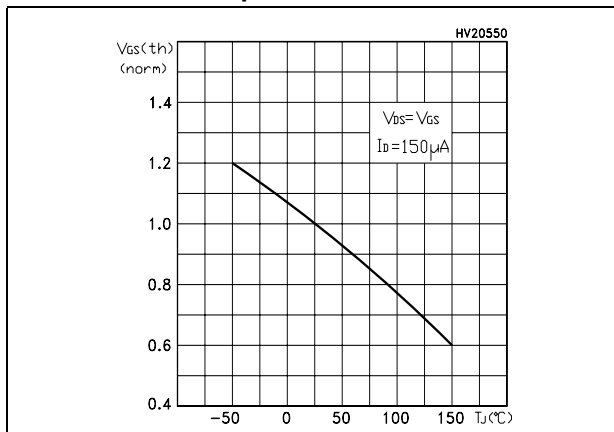

Figure 10. Normalized on resistance vs temperature

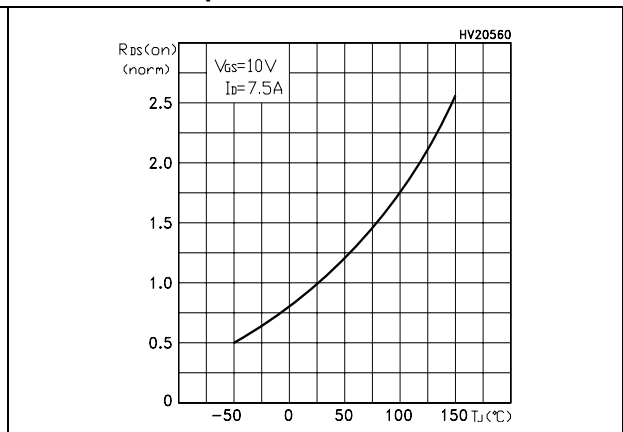

Figure 11. Source-drain diode forward characteristics

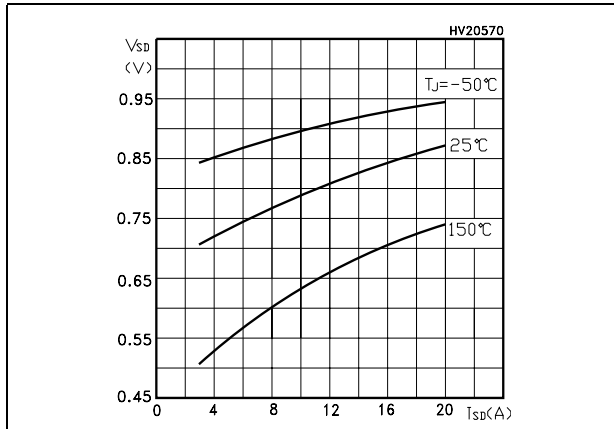

Figure 12. Normalized  $B_{VDSS}$  vs temperature

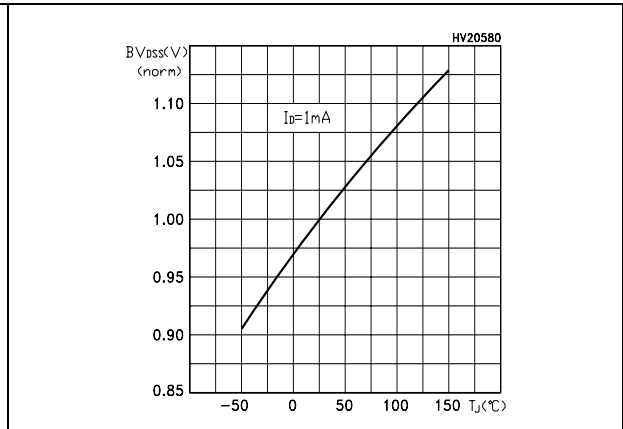
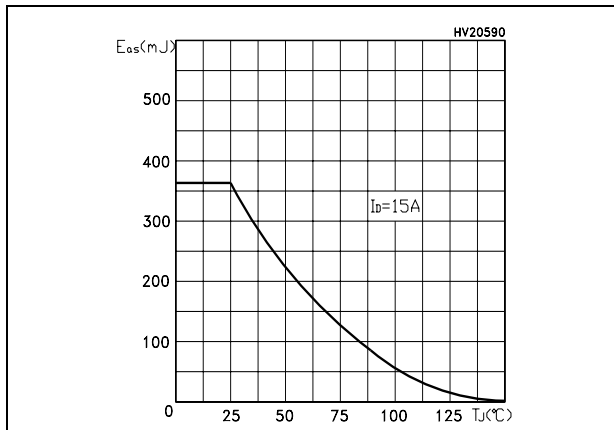

Figure 13. Maximum avalanche energy vs temperature



### 3 Test circuit Package mechanical data

Figure 14. Unclamped Inductive load test circuit

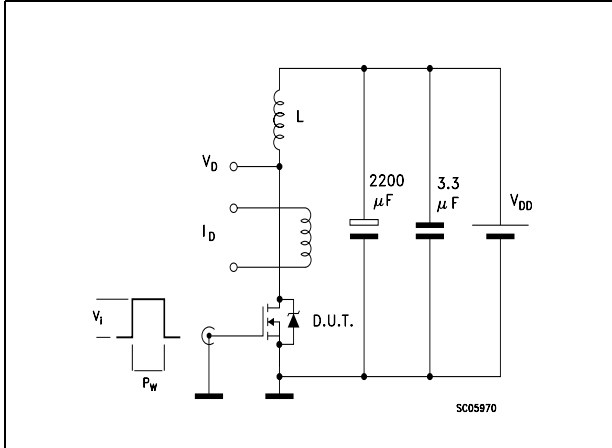

Figure 15. Unclamped Inductive waveform

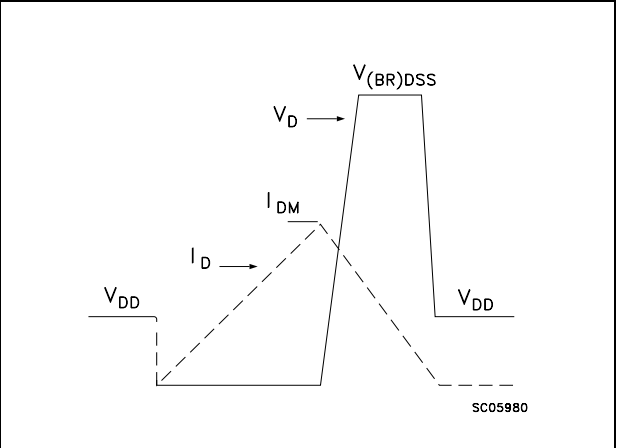

Figure 16. Switching times test circuit for resistive load

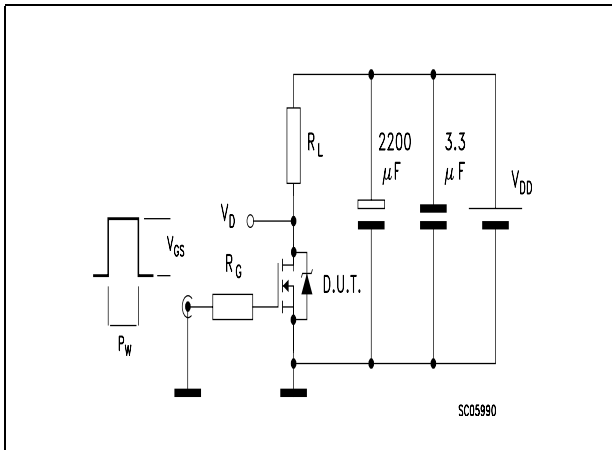

Figure 17. Gate charge test circuit

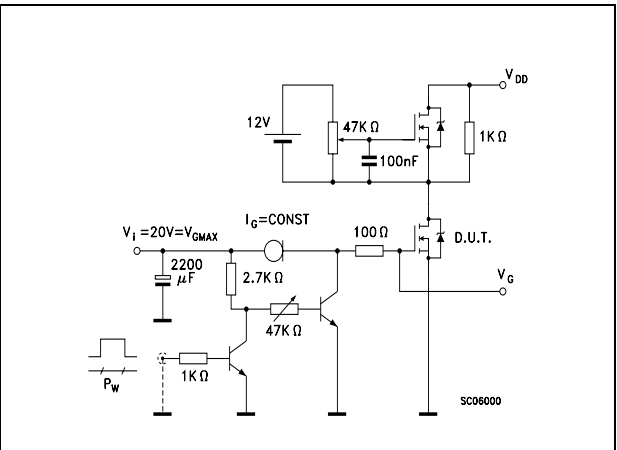
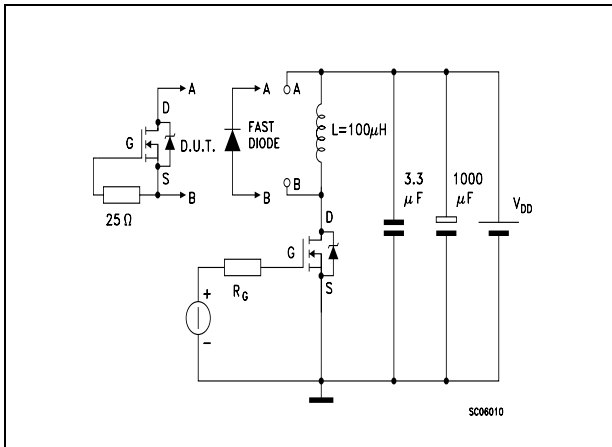

Figure 18. Test circuit for inductive load switching and diode recovery times



## 4 Package mechanical data

In order to meet environmental requirements, ST offers these devices in ECOPACK® packages. These packages have a Lead-free second level interconnect . The category of second level interconnect is marked on the package and on the inner box label, in compliance with JEDEC Standard JESD97. The maximum ratings related to soldering conditions are also marked on the inner box label. ECOPACK is an ST trademark. ECOPACK specifications are available at: [www.st.com](http://www.st.com)

**TO-247 MECHANICAL DATA**

DIM.	mm.			inch		
	MIN.	TYP	MAX.	MIN.	TYP.	MAX.
A	4.85		5.15	0.19		0.20
A1	2.20		2.60	0.086		0.102
b	1.0		1.40	0.039		0.055
b1	2.0		2.40	0.079		0.094
b2	3.0		3.40	0.118		0.134
c	0.40		0.80	0.015		0.03
D	19.85		20.15	0.781		0.793
E	15.45		15.75	0.608		0.620
e		5.45			0.214	
L	14.20		14.80	0.560		0.582
L1	3.70		4.30	0.14		0.17
L2		18.50			0.728	
øP	3.55		3.65	0.140		0.143
øR	4.50		5.50	0.177		0.216
S		5.50			0.216	

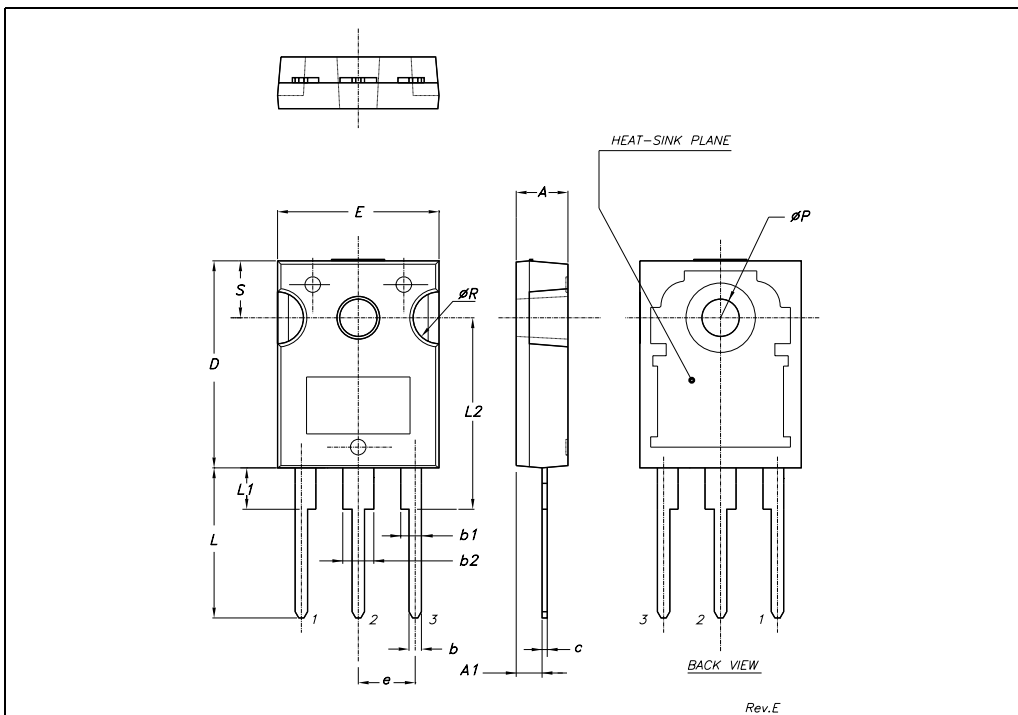

## 5 Revision history

**Table 8. Revision history**

<b>Date</b>	<b>Revision</b>	<b>Changes</b>
09-Sep-2004	1	Preliminary
08-Sep-2005	2	Complete datasheet
31-Jul-2005	3	New template, no content change

**Please Read Carefully:**

Information in this document is provided solely in connection with ST products. STMicroelectronics NV and its subsidiaries ("ST") reserve the right to make changes, corrections, modifications or improvements, to this document, and the products and services described herein at any time, without notice.

All ST products are sold pursuant to ST's terms and conditions of sale.

Purchasers are solely responsible for the choice, selection and use of the ST products and services described herein, and ST assumes no liability whatsoever relating to the choice, selection or use of the ST products and services described herein.

No license, express or implied, by estoppel or otherwise, to any intellectual property rights is granted under this document. If any part of this document refers to any third party products or services it shall not be deemed a license grant by ST for the use of such third party products or services, or any intellectual property contained therein or considered as a warranty covering the use in any manner whatsoever of such third party products or services or any intellectual property contained therein.

**UNLESS OTHERWISE SET FORTH IN ST'S TERMS AND CONDITIONS OF SALE ST DISCLAIMS ANY EXPRESS OR IMPLIED WARRANTY WITH RESPECT TO THE USE AND/OR SALE OF ST PRODUCTS INCLUDING WITHOUT LIMITATION IMPLIED WARRANTIES OF MERCHANTABILITY, FITNESS FOR A PARTICULAR PURPOSE (AND THEIR EQUIVALENTS UNDER THE LAWS OF ANY JURISDICTION), OR INFRINGEMENT OF ANY PATENT, COPYRIGHT OR OTHER INTELLECTUAL PROPERTY RIGHT.**

**UNLESS EXPRESSLY APPROVED IN WRITING BY AN AUTHORIZED ST REPRESENTATIVE, ST PRODUCTS ARE NOT RECOMMENDED, AUTHORIZED OR WARRANTED FOR USE IN MILITARY, AIR CRAFT, SPACE, LIFE SAVING, OR LIFE SUSTAINING APPLICATIONS, NOR IN PRODUCTS OR SYSTEMS WHERE FAILURE OR MALFUNCTION MAY RESULT IN PERSONAL INJURY, DEATH, OR SEVERE PROPERTY OR ENVIRONMENTAL DAMAGE. ST PRODUCTS WHICH ARE NOT SPECIFIED AS "AUTOMOTIVE GRADE" MAY ONLY BE USED IN AUTOMOTIVE APPLICATIONS AT USER'S OWN RISK.**

Resale of ST products with provisions different from the statements and/or technical features set forth in this document shall immediately void any warranty granted by ST for the ST product or service described herein and shall not create or extend in any manner whatsoever, any liability of ST.

ST and the ST logo are trademarks or registered trademarks of ST in various countries.

Information in this document supersedes and replaces all information previously supplied.

The ST logo is a registered trademark of STMicroelectronics. All other names are the property of their respective owners.

© 2006 STMicroelectronics - All rights reserved

STMicroelectronics group of companies

Australia - Belgium - Brazil - Canada - China - Czech Republic - Finland - France - Germany - Hong Kong - India - Israel - Italy - Japan - Malaysia - Malta - Morocco - Singapore - Spain - Sweden - Switzerland - United Kingdom - United States of America

[www.st.com](http://www.st.com)