



STN1N20

N-channel 200 V, 1.2 Ω , 1 A, SOT-223
MESH OVERLAY™ Power MOSFET

Features

Type	V _{DSS}	R _{DS(on)} max	I _D
STN1N20	200 V	< 1.5 Ω	1 A

- 100% avalanche tested

Application

- Switching applications

Description

This device is an N-channel Power MOSFET developed using the latest high voltage MESH OVERLAY™ process. The new patented STrip layout coupled with the company's proprietary edge termination structure, makes it suitable in converters for lighting applications.

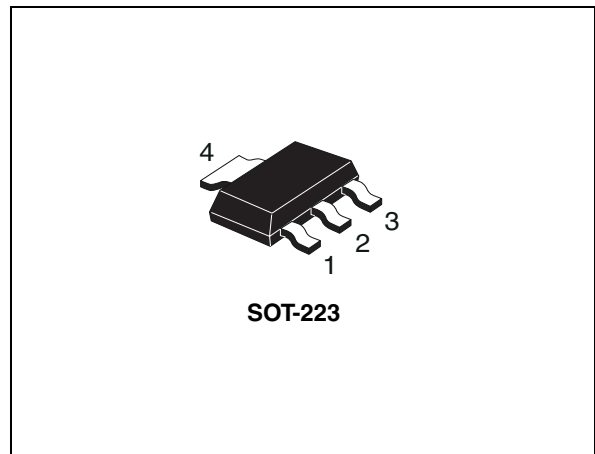

Figure 1. Internal schematic diagram

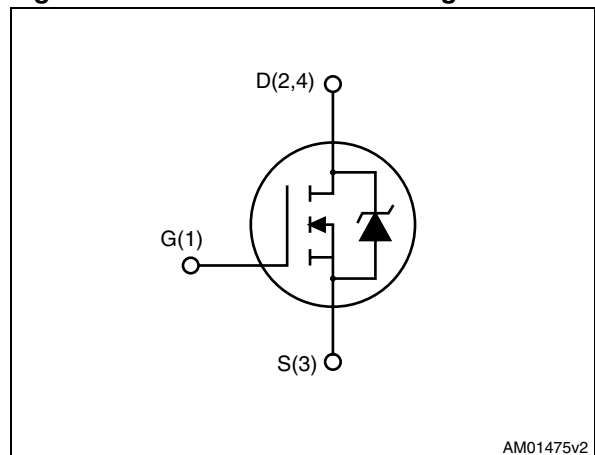

Table 1. Device summary

Order code	Marking	Package	Packaging
STN1N20	N1N20	SOT-223	Tape and reel

Contents

1	Electrical ratings	3
2	Electrical characteristics	4
	2.1 Electrical characteristics (curves)	6
3	Test circuits	8
4	Package mechanical data	9
5	Revision history	11

1 Electrical ratings

Table 2. Absolute maximum ratings

Symbol	Parameter	Value	Unit
V_{DS}	Drain-source voltage ($V_{GS}=0$)	200	V
V_{GS}	Gate-source voltage	± 20	V
I_D	Drain current (continuous) at $T_C = 25\text{ }^\circ\text{C}$	1	A
I_D	Drain current (continuous) at $T_C = 100\text{ }^\circ\text{C}$	0.6	A
$I_{DM}^{(1)}$	Drain current (pulsed)	4	A
P_{TOT}	Total dissipation at $T_C = 25\text{ }^\circ\text{C}$	2.9	W
	Derating factor	0.023	W/ $^\circ\text{C}$
dv/dt	Peak diode recovery voltage slope	6	V/ns
T_j T_{stg}	Operating junction temperature Storage temperature	-55 to 150	$^\circ\text{C}$

1. Pulse width limited by safe operating area

Table 3. Thermal data

Symbol	Parameter	Value	Unit
$R_{thj-pcb}$	Thermal resistance junction-pcb max	43	$^\circ\text{C}/\text{W}$
$R_{thj-amb}$	Thermal resistance junction-ambient max	60	$^\circ\text{C}/\text{W}$
T_l	Maximum lead temperature for soldering purpose	260	$^\circ\text{C}$

Table 4. Avalanche characteristics

Symbol	Parameter	Value	Unit
I_{AR}	Max current during repetitive or single pulse avalanche (pulse width limited by T_{JMAX})	1	A
E_{AS}	Single pulse avalanche energy ⁽¹⁾	10	mJ

1. Starting $T_j = 25\text{ }^\circ\text{C}$, $I_D = I_{AR}$, $V_{DD} = 50\text{ V}$

2 Electrical characteristics

(T_{case} = 25 °C unless otherwise specified)

Table 5. On /off states

Symbol	Parameter	Test conditions	Min.	Typ.	Max.	Unit
V _{(BR)DSS}	Drain-source breakdown voltage (V _{GS} = 0)	I _D = 250 μA	200			V
I _{DSS}	Zero gate voltage drain current (V _{GS} = 0)	V _{DS} = Max rating V _{DS} = Max rating, T _C =125 °C			1 100	μA μA
I _{GSS}	Gate-body leakage current (V _{DS} = 0)	V _{GS} = ± 20 V			±100	nA
V _{GS(th)}	Gate threshold voltage	V _{DS} = V _{GS} , I _D = 250 μA	2	3	4	V
R _{DS(on)}	Static drain-source on resistance	V _{GS} = 10 V, I _D = 0.5 A		1.2	1.5	Ω

Table 6. Dynamic

Symbol	Parameter	Test conditions	Min.	Typ.	Max.	Unit
g _{fs} (1)	Forward transconductance	V _{DS} > I _{D(on)} × R _{DS(on)max} , I _D = 0.5 A	-	2.7		S
C _{iss} C _{oss} C _{rss}	Input capacitance Output capacitance Reverse transfer capacitance	V _{DS} = 25 V, f = 1 MHz, V _{GS} = 0	-	206 40 15		pF pF pF
Q _g Q _{gs} Q _{gd}	Total gate charge Gate-source charge Gate-drain charge	V _{DD} = 160 V, I _D = 4 A, V _{GS} = 10 V (see Figure 14)	-	11 2.8 4	15.7	nC nC nC

1. Pulsed: pulse duration = 300 μs, duty cycle 1.5%

Table 7. Switching times

Symbol	Parameter	Test conditions	Min.	Typ.	Max	Unit
t _{d(on)}	Turn-on delay time	V _{DD} = 160 V, I _D = 4 A, R _G = 4.7 Ω, V _{GS} = 10 V (see Figure 13)	-	9	-	ns
t _r	Rise time			10		ns
t _{d(off)}	Turn-off delay time			25		ns
t _f	Fall time			6		ns

Table 8. Source drain diode

Symbol	Parameter	Test conditions	Min.	Typ.	Max.	Unit
I_{SD}	Source-drain current		-		1	A
$I_{SDM}^{(1)}$	Source-drain current (pulsed)		-		4	A
$V_{SD}^{(2)}$	Forward on voltage	$I_{SD} = 1 \text{ A}, V_{GS} = 0$	-		1.5	V
t_{rr}	Reverse recovery time	$I_{SD} = 4 \text{ A}, di/dt = 100 \text{ A}/\mu\text{s}$	-	124		ns
Q_{rr}	Reverse recovery charge	$V_{DD} = 30 \text{ V}, T_j = 150 \text{ }^\circ\text{C}$	-	446		nC
I_{RRM}	Reverse recovery current	(see Figure 18)	-	7.2		A

1. Pulse width limited by safe operating area.

2. Pulse duration = 300 μs , duty cycle 1.5%

2.1 Electrical characteristics (curves)

Figure 2. Safe operating area

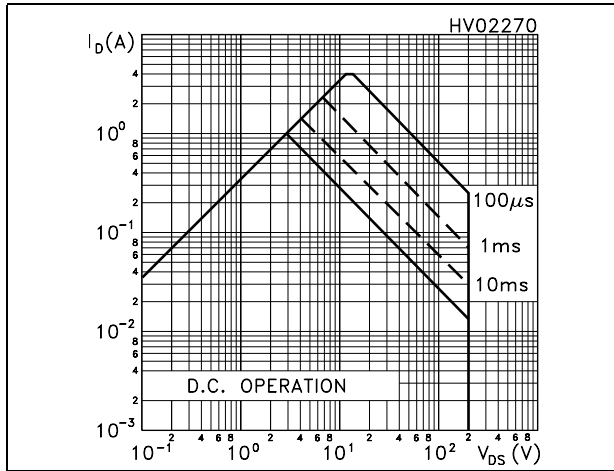

Figure 3. Thermal impedance

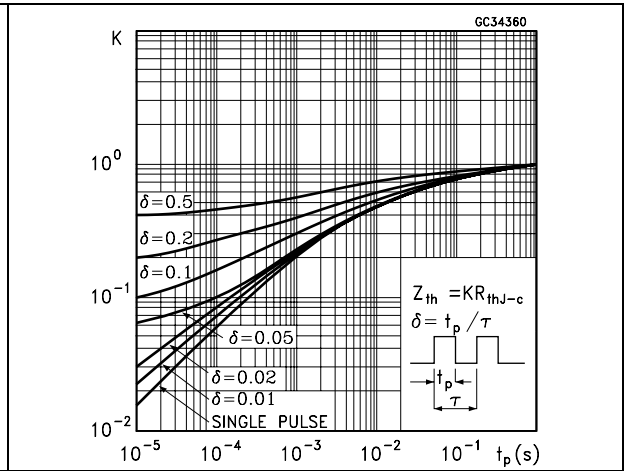

Figure 4. Output characteristics

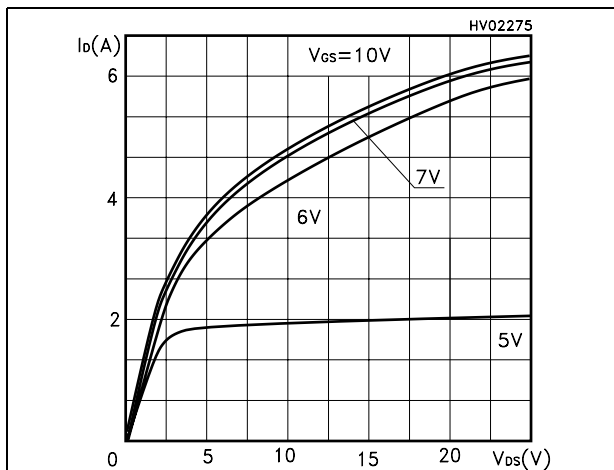

Figure 5. Transfer characteristics

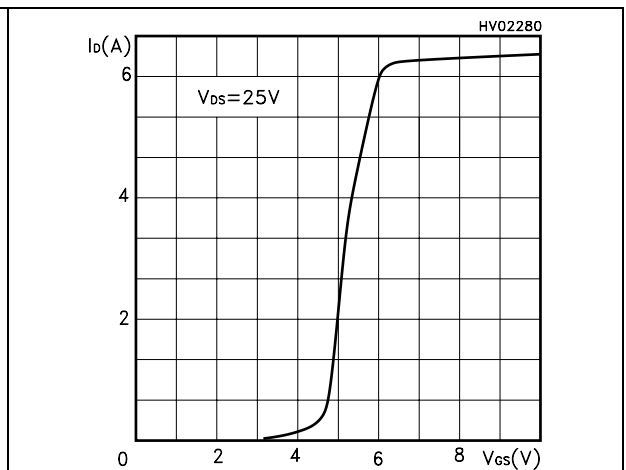

Figure 6. Transconductance

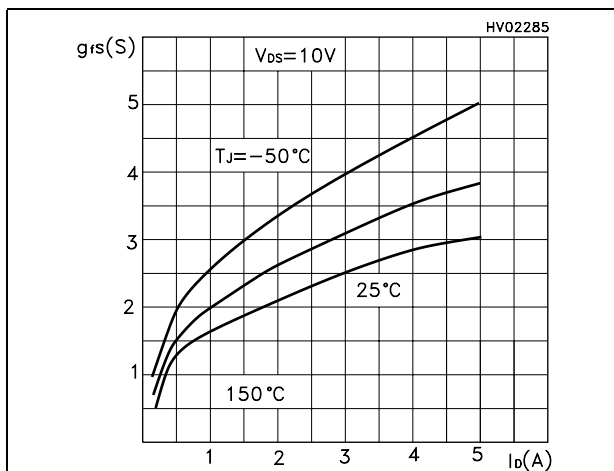

Figure 7. Static drain-source on resistance

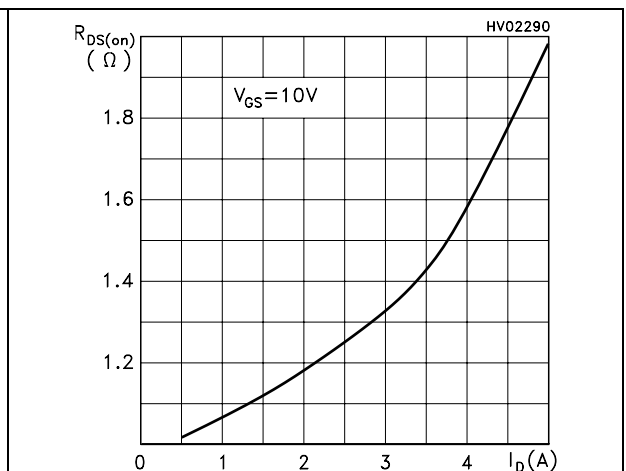

Figure 8. Gate charge vs gate-source voltage Figure 9. Capacitance variations

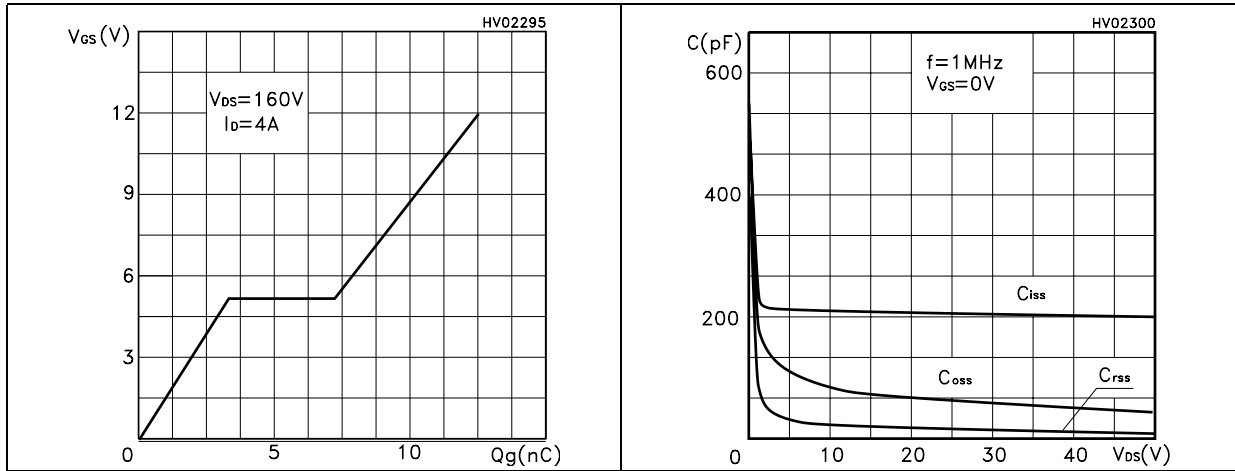

Figure 10. Normalized gate threshold voltage vs temperature Figure 11. Normalized on resistance vs temperature

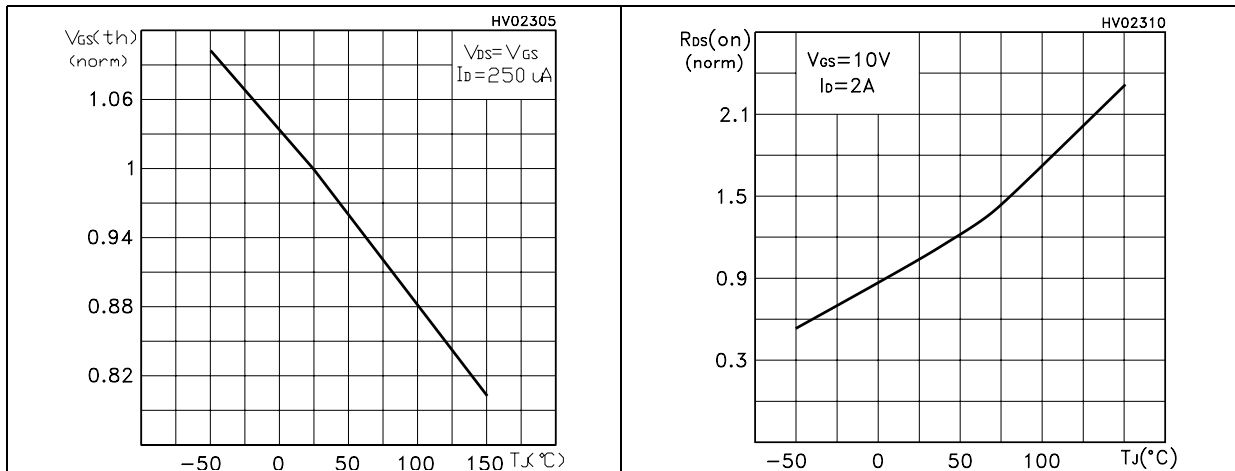
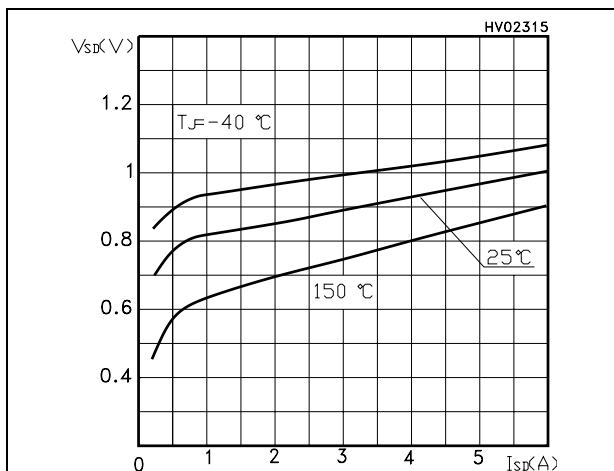
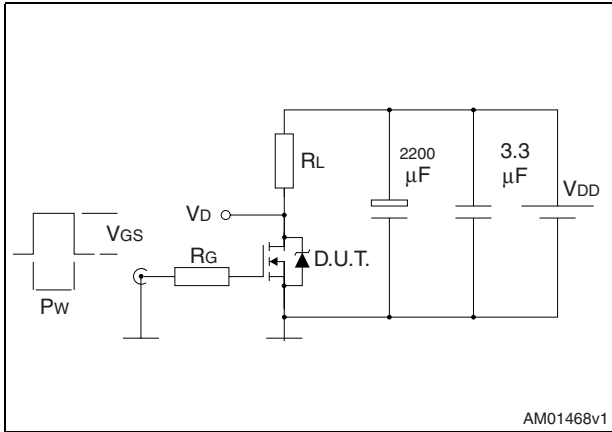

Figure 12. Source-drain diode forward characteristics



3 Test circuits

Figure 13. Switching times test circuit for resistive load



AM01468v1

Figure 14. Gate charge test circuit

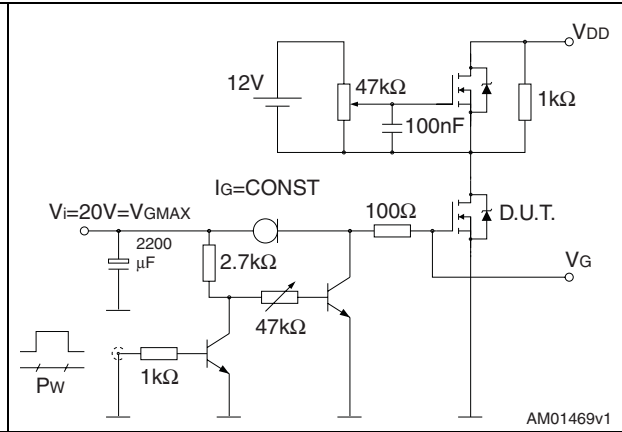

AM01469v1

Figure 15. Test circuit for inductive load switching and diode recovery times

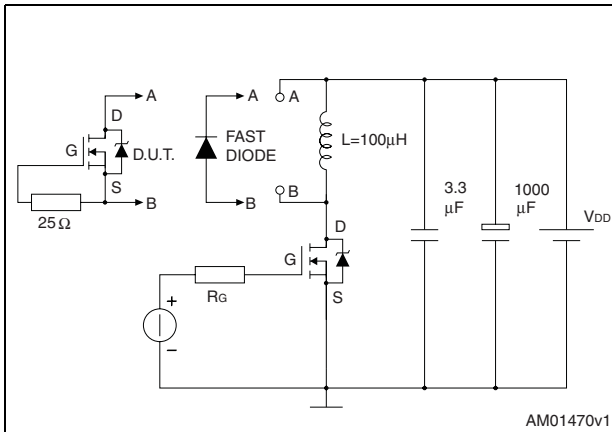

AM01470v1

Figure 16. Unclamped inductive load test circuit

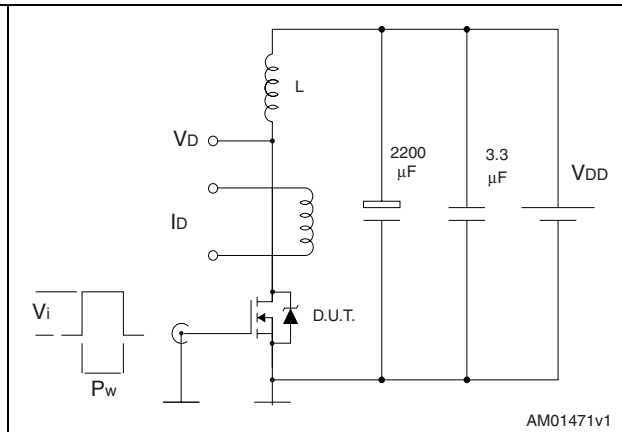

AM01471v1

Figure 17. Unclamped inductive waveform

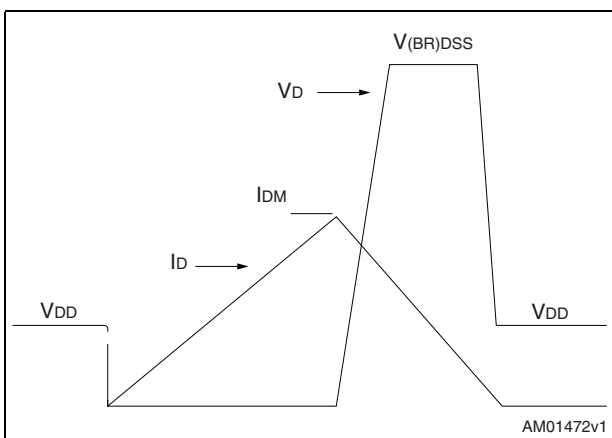

AM01472v1

Figure 18. Switching time waveform

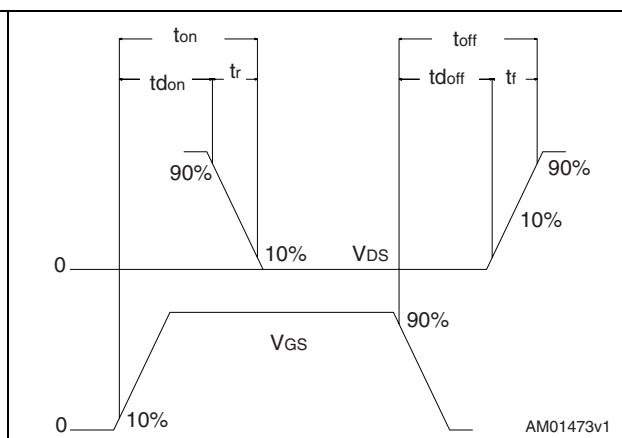

AM01473v1

4 Package mechanical data

In order to meet environmental requirements, ST offers these devices in different grades of ECOPACK® packages, depending on their level of environmental compliance. ECOPACK® specifications, grade definitions and product status are available at: www.st.com. ECOPACK is an ST trademark.

Table 9. SOT-223 mechanical data

Dim.	mm		
	Min.	Typ.	Max.
A			1.80
A1	0.02		0.1
B	0.60	0.70	0.85
B1	2.90	3.00	3.15
c	0.24	0.26	0.35
D	6.30	6.50	6.70
e		2.30	
e1		4.60	
E	3.30	3.50	3.70
H	6.70	7.00	7.30
V			10°

Figure 19. SOT-223 mechanical data drawing

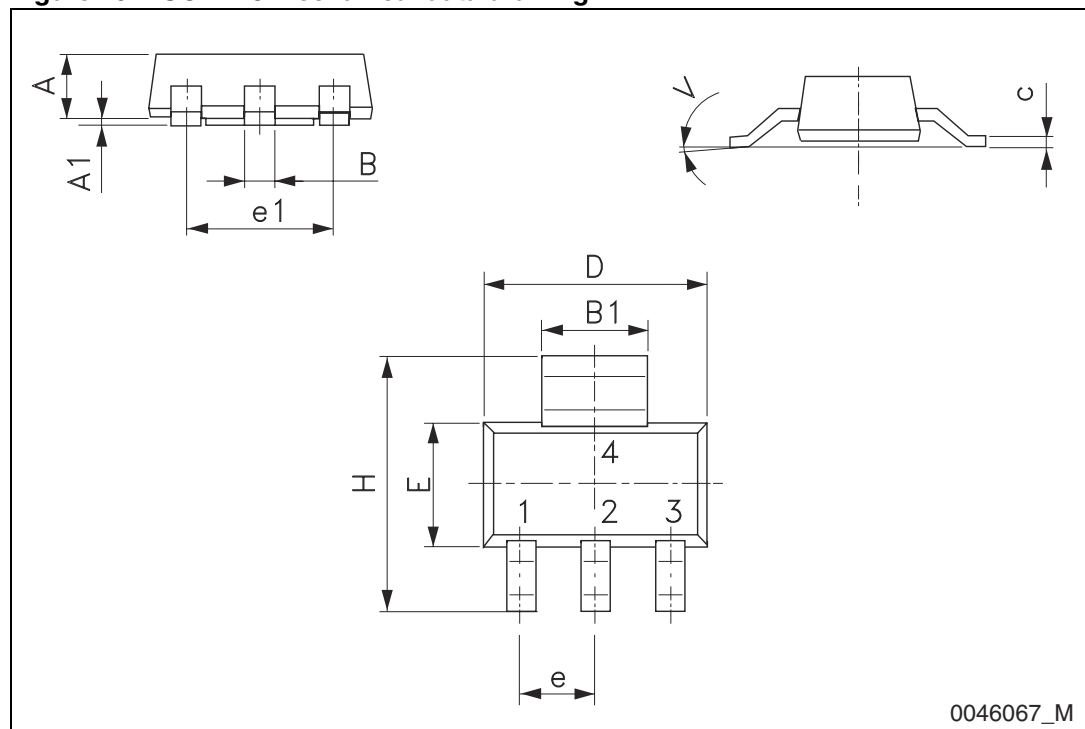

5 Revision history

Table 10. Document revision history

Date	Revision	Changes
21-Jun-2004	1	First release.
31-Mar-2009	2	Document status promoted from preliminary data to datasheet.
27-Jun-2011	3	Updated gate threshold voltage values on Table 5 and the package mechanical data Section 4 .

Please Read Carefully:

Information in this document is provided solely in connection with ST products. STMicroelectronics NV and its subsidiaries ("ST") reserve the right to make changes, corrections, modifications or improvements, to this document, and the products and services described herein at any time, without notice.

All ST products are sold pursuant to ST's terms and conditions of sale.

Purchasers are solely responsible for the choice, selection and use of the ST products and services described herein, and ST assumes no liability whatsoever relating to the choice, selection or use of the ST products and services described herein.

No license, express or implied, by estoppel or otherwise, to any intellectual property rights is granted under this document. If any part of this document refers to any third party products or services it shall not be deemed a license grant by ST for the use of such third party products or services, or any intellectual property contained therein or considered as a warranty covering the use in any manner whatsoever of such third party products or services or any intellectual property contained therein.

UNLESS OTHERWISE SET FORTH IN ST'S TERMS AND CONDITIONS OF SALE ST DISCLAIMS ANY EXPRESS OR IMPLIED WARRANTY WITH RESPECT TO THE USE AND/OR SALE OF ST PRODUCTS INCLUDING WITHOUT LIMITATION IMPLIED WARRANTIES OF MERCHANTABILITY, FITNESS FOR A PARTICULAR PURPOSE (AND THEIR EQUIVALENTS UNDER THE LAWS OF ANY JURISDICTION), OR INFRINGEMENT OF ANY PATENT, COPYRIGHT OR OTHER INTELLECTUAL PROPERTY RIGHT.

UNLESS EXPRESSLY APPROVED IN WRITING BY AN AUTHORIZED ST REPRESENTATIVE, ST PRODUCTS ARE NOT RECOMMENDED, AUTHORIZED OR WARRANTED FOR USE IN MILITARY, AIR CRAFT, SPACE, LIFE SAVING, OR LIFE SUSTAINING APPLICATIONS, NOR IN PRODUCTS OR SYSTEMS WHERE FAILURE OR MALFUNCTION MAY RESULT IN PERSONAL INJURY, DEATH, OR SEVERE PROPERTY OR ENVIRONMENTAL DAMAGE. ST PRODUCTS WHICH ARE NOT SPECIFIED AS "AUTOMOTIVE GRADE" MAY ONLY BE USED IN AUTOMOTIVE APPLICATIONS AT USER'S OWN RISK.

Resale of ST products with provisions different from the statements and/or technical features set forth in this document shall immediately void any warranty granted by ST for the ST product or service described herein and shall not create or extend in any manner whatsoever, any liability of ST.

ST and the ST logo are trademarks or registered trademarks of ST in various countries.

Information in this document supersedes and replaces all information previously supplied.

The ST logo is a registered trademark of STMicroelectronics. All other names are the property of their respective owners.

© 2011 STMicroelectronics - All rights reserved

STMicroelectronics group of companies

Australia - Belgium - Brazil - Canada - China - Czech Republic - Finland - France - Germany - Hong Kong - India - Israel - Italy - Japan - Malaysia - Malta - Morocco - Philippines - Singapore - Spain - Sweden - Switzerland - United Kingdom - United States of America

www.st.com