

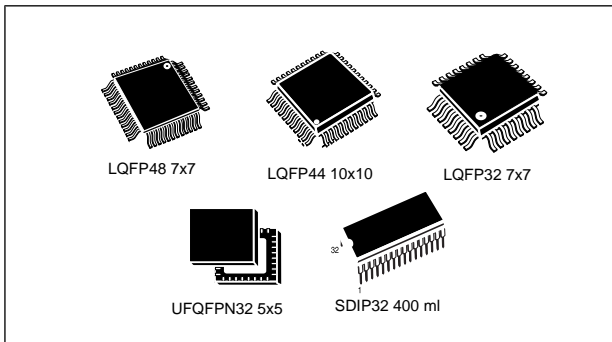

Access line, 16 MHz STM8S 8-bit MCU, up to 32 Kbytes Flash, integrated EEPROM, 10-bit ADC, timers, UART, SPI, I²C



Features

Core

- 16 MHz advanced STM8 core with Harvard architecture and 3-stage pipeline
- Extended instruction set

Memories

- Medium-density Flash/EEPROM:
 - Program memory up to 32 Kbytes; data retention 20 years at 55°C after 10 kcycles
 - Data memory up to 1 Kbytes true data EEPROM; endurance 300 kcycles
- RAM: Up to 2 Kbytes

Clock, reset and supply management

- 2.95 V to 5.5 V operating voltage
- Flexible clock control, 4 master clock sources:
 - Low power crystal resonator oscillator
 - External clock input
 - Internal, user-trimmable 16 MHz RC
 - Internal low power 128 kHz RC
- Clock security system with clock monitor
- Power management:
 - Low power modes (wait, active-halt, halt)
 - Switch-off peripheral clocks individually
- Permanently active, low consumption power-on and power-down reset

Interrupt management

- Nested interrupt controller with 32 interrupts
- Up to 37 external interrupts on 6 vectors

Timers

- 2x 16-bit general purpose timers, with 2+3 CAPCOM channels (IC, OC or PWM)
- Advanced control timer: 16-bit, 4 CAPCOM channels, 3 complementary outputs, dead-time insertion and flexible synchronization
- 8-bit basic timer with 8-bit prescaler
- Auto wake-up timer
- Window and independent watchdog timers

Communications interfaces

- UART with clock output for synchronous operation, Smartcard, IrDA, LIN
- SPI interface up to 8 Mbit/s
- I²C interface up to 400 Kbit/s

Analog-to-digital converter (ADC)

- 10-bit, ± 1 LSB ADC with up to 10 multiplexed channels, scan mode and analog watchdog

I/Os

- Up to 38 I/Os on a 48-pin package including 16 high sink outputs
- Highly robust I/O design, immune against current injection

Development support

- Embedded single wire interface module (SWIM) for fast on-chip programming and non intrusive debugging

Unique ID

- 96-bit unique key for each device

Table 1: Device summary

Reference	Part number
STM8S105xx	STM8S105K4, STM8S105K6, STM8S105S4, STM8S105S6, STM8S105C4, STM8S105C6

Contents

1 Introduction	8
2 Description	9
3 Block diagram	10
4 Product overview	11
4.1 Central processing unit STM8	11
4.2 Single wire interface module (SWIM) and debug module (DM)	11
4.3 Interrupt controller	12
4.4 Flash program and data EEPROM memory	12
4.5 Clock controller	13
4.6 Power management	14
4.7 Watchdog timers	15
4.8 Auto wakeup counter	15
4.9 Beeper	15
4.10 TIM1 - 16-bit advanced control timer	16
4.11 TIM2, TIM3 - 16-bit general purpose timers	16
4.12 TIM4 - 8-bit basic timer	16
4.13 Analog-to-digital converter (ADC1)	17
4.14 Communication interfaces	17
4.14.1 UART2	17
4.14.2 SPI	18
4.14.3 I ² C	19
5 Pinout and pin description	20
5.1 STM8S105 pinouts and pin description	21
5.1.1 Alternate function remapping	27
6 Memory and register map	29
6.1 Memory map	29
6.2 Register map	30
6.2.1 I/O port hardware register map	30
6.2.2 General hardware register map	33
6.2.3 CPU/SWIM/debug module/interrupt controller registers	44
7 Interrupt vector mapping	47
8 Option bytes	49
9 Unique ID	54
10 Electrical characteristics	55
10.1 Parameter conditions	55
10.1.1 Minimum and maximum values	55
10.1.2 Typical values	55

10.1.3 Typical curves	55
10.1.4 Typical current consumption	55
10.1.5 Loading capacitor	56
10.1.6 Pin input voltage	56
10.2 Absolute maximum ratings	56
10.3 Operating conditions	58
10.3.1 VCAP external capacitor	61
10.3.2 Supply current characteristics	61
10.3.3 External clock sources and timing characteristics	73
10.3.4 Internal clock sources and timing characteristics	75
10.3.5 Memory characteristics	78
10.3.6 I/O port pin characteristics	79
10.3.7 Typical output level curves	83
10.3.8 Reset pin characteristics	88
10.3.9 SPI serial peripheral interface	91
10.3.10 I ² C interface characteristics	94
10.3.11 10-bit ADC characteristics	96
10.3.12 EMC characteristics	99
11 Package information	103
11.1 48-pin LQFP package mechanical data	103
11.2 44-pin LQFP package mechanical data	105
11.3 32-pin LQFP package mechanical data	106
11.4 32-lead UFQFPN package mechanical data	108
11.5 SDIP32 package mechanical data	109
12 Thermal characteristics	111
12.1 Reference document	112
12.2 Selecting the product temperature range	112
13 Ordering information	113
13.1 STM8S105 FASTROM microcontroller option list	113
14 STM8 development tools	118
14.1 Emulation and in-circuit debugging tools	118
14.2 Software tools	118
14.2.1 STM8 toolset	119
14.2.2 C and assembly toolchains	119
14.3 Programming tools	119
15 Revision history	120

List of tables

Table 1. Device summary	1
Table 2. STM8S105xx access line features	9
Table 3. Peripheral clock gating bit assignments in CLK_PCKENR1/2 registers	14
Table 4. TIM timer features	16
Table 5. Legend/abbreviations for pinout tables	20
Table 6. Pin description for STM8S105 microcontrollers	24
Table 7. Flash, Data EEPROM and RAM boundary addresses	105
Table 8. I/O port hardware register map	108
Table 9. General hardware register map	33
Table 10. CPU/SWIM/debug module/interrupt controller registers	109
Table 11. Interrupt mapping	47
Table 12. Option bytes	54
Table 13. Option byte description	50
Table 14. Description of alternate function remapping bits [7:0] of OPT2	52
Table 15. Unique ID registers (96 bits)	54
Table 16. Voltage characteristics	56
Table 17. Current characteristics	57
Table 18. Thermal characteristics	58
Table 19. General operating conditions	59
Table 20. Operating conditions at power-up/power-down	60
Table 21. Total current consumption with code execution in run mode at $V_{DD} = 5\text{ V}$	61
Table 22. Total current consumption with code execution in run mode at $V_{DD} = 3.3\text{ V}$	73
Table 23. Total current consumption in wait mode at $V_{DD} = 5\text{ V}$	64
Table 24. Total current consumption in wait mode at $V_{DD} = 3.3\text{ V}$	65
Table 25. Total current consumption in active halt mode at $V_{DD} = 5\text{ V}$	65
Table 26. Total current consumption in active halt mode at $V_{DD} = 3.3\text{ V}$	66
Table 27. Total current consumption in halt mode at $V_{DD} = 5\text{ V}$	67
Table 28. Total current consumption in halt mode at $V_{DD} = 3.3\text{ V}$	68
Table 29. Wakeup times	68
Table 30. Total current consumption and timing in forced reset state	102
Table 31. Peripheral current consumption	69
Table 32. HSE user external clock characteristics	73
Table 33. HSE oscillator characteristics	74
Table 34. HSI oscillator characteristics	75
Table 35. LSI oscillator characteristics	77
Table 36. RAM and hardware registers	78
Table 37. Flash program memory/data EEPROM memory	78
Table 38. I/O static characteristics	79
Table 39. Output driving current (standard ports)	82
Table 40. Output driving current (true open drain ports)	82
Table 41. Output driving current (high sink ports)	83
Table 42. NRST pin characteristics	88
Table 43. SPI characteristics	91
Table 44. I ² C characteristics	94
Table 45. ADC characteristics	96
Table 46. ADC accuracy with $R_{AIN} < 10\text{ k}\Omega$, $V_{DDA} = 5\text{ V}$	97
Table 47. ADC accuracy with $R_{AIN} < 10\text{ k}\Omega$, $V_{DDA} = 3.3\text{ V}$	98

Table 48. EMS data100
Table 49. EMI data101
Table 50. ESD absolute maximum ratings102
Table 51. Electrical sensitivities102
Table 52. 48-pin low profile quad flat package mechanical data103
Table 53. 44-pin low profile quad flat package mechanical data105
Table 54. 32-pin low profile quad flat package mechanical data120
Table 55. 32-lead, ultra thin, fine pitch quad flat no-lead package mechanical data108
Table 56. 32-lead shrink plastic DIP (400 ml) package mechanical data109
Table 57. Thermal characteristics⁽¹⁾111
Table 58. Document revision history120

List of figures

Figure 1. STM8S105xx access line block diagram	10
Figure 2. Flash memory organisation	13
Figure 3. LQFP 48-pin pinout	21
Figure 4. LQFP 44-pin pinout	22
Figure 5. LQFP/UFQFPN 32-pin pinout	23
Figure 6. SDIP 32-pin pinout	24
Figure 7. Memory map	29
Figure 8. Supply current measurement conditions	55
Figure 9. Pin loading conditions	56
Figure 10. Pin input voltage	56
Figure 11. f_{CPUmax} versus V_{DD}	60
Figure 12. External capacitor C_{EXT}	61
Figure 13. Typ. $I_{DD(RUN)}$ vs. V_{DD} , HSE user external clock, $f_{CPU} = 16$ MHz	70
Figure 14. Typ. $I_{DD(RUN)}$ vs. f_{CPU} , HSE user external clock, $V_{DD} = 5$ V	71
Figure 15. Typ. $I_{DD(RUN)}$ vs. V_{DD} , HSI RC osc, $f_{CPU} = 16$ MHz	71
Figure 16. Typ. $I_{DD(WFI)}$ vs. V_{DD} , HSE user external clock, $f_{CPU} = 16$ MHz	72
Figure 17. Typ. $I_{DD(WFI)}$ vs. f_{CPU} , HSE user external clock $V_{DD} = 5$ V	72
Figure 18. Typ. $I_{DD(WFI)}$ vs. V_{DD} , HSI RC osc, $f_{CPU} = 16$ MHz	73
Figure 19. HSE external clocksource	74
Figure 20. HSE oscillator circuit diagram	75
Figure 21. Typical HSI accuracy at $V_{DD} = 5$ V vs 5 temperatures	76
Figure 22. Typical HSI accuracy vs V_{DD} @ 4 temperatures	77
Figure 23. Typical LSI accuracy vs V_{DD} @ 4 temperatures	78
Figure 24. Typical V_{IL} and V_{IH} vs V_{DD} @ 4 temperatures	81
Figure 25. Typical pull-up resistance vs V_{DD} @ 4 temperatures	81
Figure 26. Typical pull-up current vs V_{DD} @ 4 temperatures	82
Figure 27. Typ. V_{OL} @ $V_{DD} = 5$ V (standard ports)	84
Figure 28. Typ. V_{OL} @ $V_{DD} = 3.3$ V (standard ports)	84
Figure 29. Typ. V_{OL} @ $V_{DD} = 5$ V (true open drain ports)	85
Figure 30. Typ. V_{OL} @ $V_{DD} = 3.3$ V (true open drain ports)	85
Figure 31. Typ. V_{OL} @ $V_{DD} = 5$ V (high sink ports)	86
Figure 32. Typ. V_{OL} @ $V_{DD} = 3.3$ V (high sink ports)	86
Figure 33. Typ. $V_{DD} - V_{OH}$ @ $V_{DD} = 5$ V (standard ports)	87
Figure 34. Typ. $V_{DD} - V_{OH}$ @ $V_{DD} = 3.3$ V (standard ports)	87
Figure 35. Typ. $V_{DD} - V_{OH}$ @ $V_{DD} = 5$ V (high sink ports)	88
Figure 36. Typ. $V_{DD} - V_{OH}$ @ $V_{DD} = 3.3$ V (high sink ports)	88
Figure 37. Typical NRST V_{IL} and V_{IH} vs V_{DD} @ 4 temperatures	89
Figure 38. Typical NRST pull-up resistance vs V_{DD} @ 4 temperatures	90
Figure 39. Typical NRST pull-up current vs V_{DD} @ 4 temperatures	90
Figure 40. Recommended reset pin protection	91
Figure 41. SPI timing diagram - slave mode and $CPHA = 0$	93
Figure 42. SPI timing diagram - slave mode and $CPHA = 1^{(1)}$	93
Figure 43. SPI timing diagram - master mode ⁽¹⁾	94
Figure 44. Typical application with I ² C bus and timing diagram ⁽¹⁾	95
Figure 45. ADC accuracy characteristics	99
Figure 46. Typical application with ADC	99
Figure 47. 48-pin low profile quad flat package (7 x 7)	103

Figure 48. 44-pin low profile quad flat package105
Figure 49. 32-pin low profile quad flat package (7 x 7)106
Figure 50. 32-lead, ultra thin, fine pitch quad flat no-lead package (5 x 5)108
Figure 51. 32-lead shrink plastic DIP (400 ml) package109
Figure 52. STM8S105xx access line ordering information scheme113

1 Introduction

This datasheet contains the description of the device features, pinout, electrical characteristics, mechanical data and ordering information.

- For complete information on the STM8S microcontroller memory, registers and peripherals, please refer to the STM8S microcontroller family reference manual (RM0016).
- For information on programming, erasing and protection of the internal Flash memory please refer to the STM8S Flash programming manual (PM0051).
- For information on the debug and SWIM (single wire interface module) refer to the STM8 SWIM communication protocol and debug module user manual (UM0470).
- For information on the STM8 core, please refer to the STM8 CPU programming manual (PM0044).

2 Description

The STM8S105xx access line 8-bit microcontrollers offer from 16 to 32 Kbytes Flash program memory, plus integrated true data EEPROM. They are referred to as medium-density devices in the STM8S microcontroller family reference manual (RM0016).

All devices of the STM8S105xx access line provide the following benefits: reduced system cost, performance and robustness, short development cycles, and product longevity.

The system cost is reduced thanks to an integrated true data EEPROM for up to 300 kwrite/erase cycles and a high system integration level with internal clock oscillators, watchdog, and brown-out reset.

Device performance is ensured by a 16 MHz CPU clock frequency and enhanced characteristics which include robust I/O, independent watchdogs (with a separate clock source), and a clock security system.

Short development cycles are guaranteed due to application scalability across a common family product architecture with compatible pinout, memory map and modular peripherals. Full documentation is offered with a wide choice of development tools.

Product longevity is ensured in the STM8S family thanks to their advanced core which is made in a state-of-the art technology for applications with 2.95 V to 5.5 V operating supply.

Table 2: STM8S105xx access line features

Device	STM8S105C6	STM8S105C4	STM8S105S6	STM8S105S4	STM8S105K6	STM8S105K4
Pin count	48	48	44	44	32	32
Maximum number of GPIOs	38	38	34	34	25	25
Ext. Interrupt pins	35	35	31	31	23	23
Timer CAPCOM channels	9	9	8	8	8	8
Timer complementary outputs	3	3	3	3	3	3
A/D Converter channels	10	10	9	9	7	7
High sink I/Os	16	16	15	15	12	12
Medium density Flash Program memory (bytes)	32K	16K	32K	16K	32K	16K
Data EEPROM (bytes)	1024	1024	1024	1024	1024	1024
RAM (bytes)	2K	2K	2K	2K	2K	2K
Peripheral set	Advanced control timer (TIM1), General-purpose timers (TIM2 and TIM3), Basic timer (TIM4) SPI, I ² C, UART, Window WDG, Independent WDG, ADC					

3 Block diagram

Figure 1: STM8S105xx access line block diagram

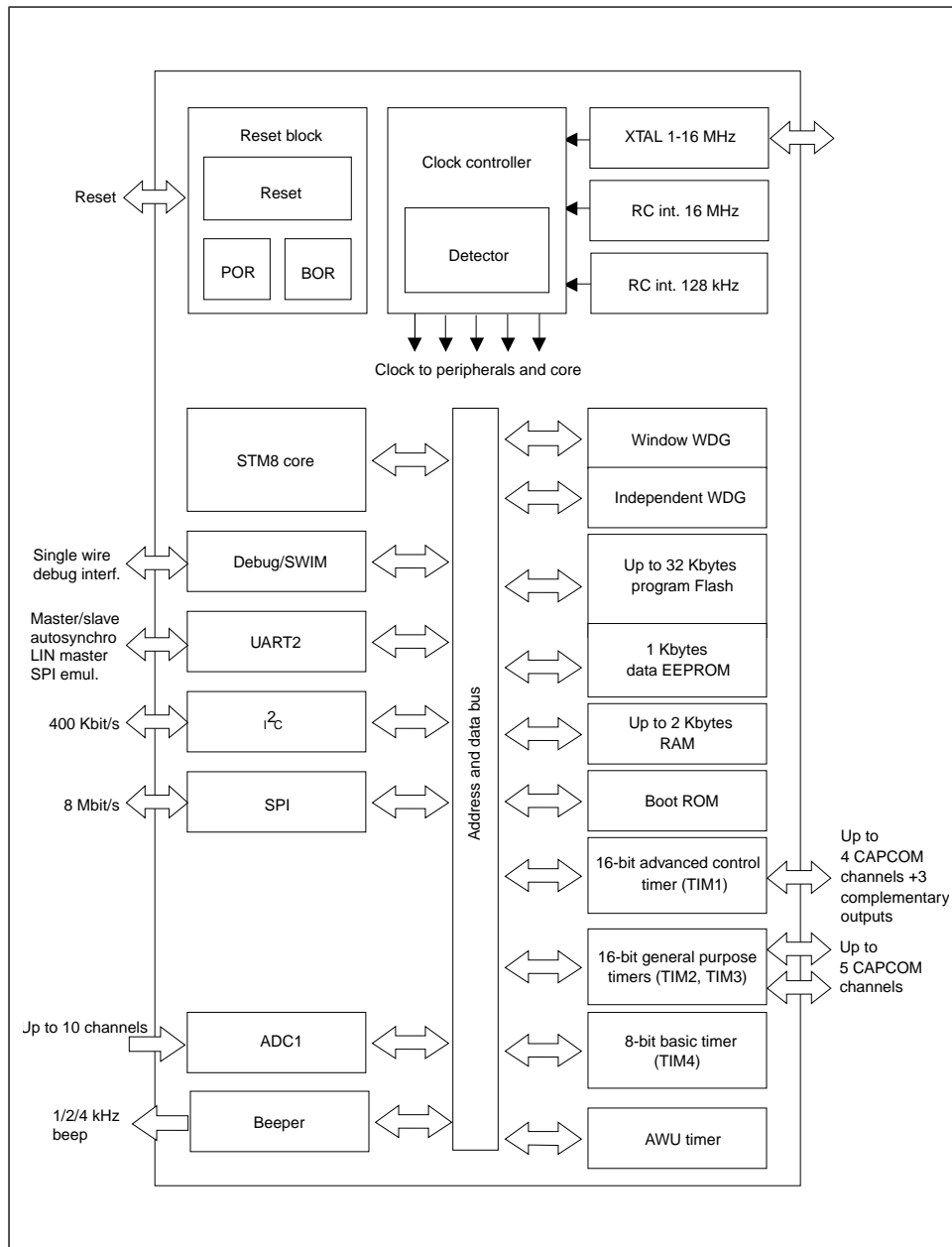

4 Product overview

The following section intends to give an overview of the basic features of the device functional modules and peripherals.

For more detailed information please refer to the corresponding family reference manual (RM0016).

4.1 Central processing unit STM8

The 8-bit STM8 core is designed for code efficiency and performance.

It contains 6 internal registers which are directly addressable in each execution context, 20 addressing modes including indexed indirect and relative addressing and 80 instructions.

Architecture and registers

- Harvard architecture
- 3-stage pipeline
- 32-bit wide program memory bus - single cycle fetching for most instructions
- X and Y 16-bit index registers - enabling indexed addressing modes with or without offset and read-modify-write type data manipulations
- 8-bit accumulator
- 24-bit program counter - 16-Mbyte linear memory space
- 16-bit stack pointer - access to a 64 K-level stack
- 8-bit condition code register - 7 condition flags for the result of the last instruction

Addressing

- 20 addressing modes
- Indexed indirect addressing mode for look-up tables located anywhere in the address space
- Stack pointer relative addressing mode for local variables and parameter passing

Instruction set

- 80 instructions with 2-byte average instruction size
- Standard data movement and logic/arithmetic functions
- 8-bit by 8-bit multiplication
- 16-bit by 8-bit and 16-bit by 16-bit division
- Bit manipulation
- Data transfer between stack and accumulator (push/pop) with direct stack access
- Data transfer using the X and Y registers or direct memory-to-memory transfers

4.2 Single wire interface module (SWIM) and debug module (DM)

The single wire interface module and debug module permits non-intrusive, real-time in-circuit debugging and fast memory programming.

SWIM

Single wire interface module for direct access to the debug module and memory programming. The interface can be activated in all device operation modes. The maximum data transmission speed is 145 bytes/ms.

Debug module

The non-intrusive debugging module features a performance close to a full-featured emulator. Beside memory and peripherals, also CPU operation can be monitored in real-time by means of shadow registers.

- R/W to RAM and peripheral registers in real-time
- R/W access to all resources by stalling the CPU
- Breakpoints on all program-memory instructions (software breakpoints)
- Two advanced breakpoints, 23 predefined configurations

4.3 Interrupt controller

- Nested interrupts with three software priority levels
- 32 interrupt vectors with hardware priority
- Up to 37 external interrupts on 6 vectors including TLI
- Trap and reset interrupts

4.4 Flash program and data EEPROM memory

- Up to 32 Kbytes of Flash program single voltage Flash memory
- Up to 1 Kbytes true data EEPROM
- Read while write: Writing in data memory possible while executing code in program memory
- User option byte area

Write protection (WP)

Write protection of Flash program memory and data EEPROM is provided to avoid unintentional overwriting of memory that could result from a user software malfunction.

There are two levels of write protection. The first level is known as MASS (memory access security system). MASS is always enabled and protects the main Flash program memory, data EEPROM and option bytes.

To perform in-application programming (IAP), this write protection can be removed by writing a MASS key sequence in a control register. This allows the application to write to data EEPROM, modify the contents of main program memory or the device option bytes.

A second level of write protection, can be enabled to further protect a specific area of memory known as UBC (user boot code). Refer to the figure below.

The size of the UBC is programmable through the UBC option byte, in increments of 1 page (512 bytes) by programming the UBC option byte in ICP mode.

This divides the program memory into two areas:

- Main program memory: Up to 32 Kbytes minus UBC
- User-specific boot code (UBC): Configurable up to 32 Kbytes

The UBC area remains write-protected during in-application programming. This means that the MASS keys do not unlock the UBC area. It protects the memory used to store the boot program, specific code libraries, reset and interrupt vectors, the reset routine and usually the IAP and communication routines.

Figure 2: Flash memory organisation

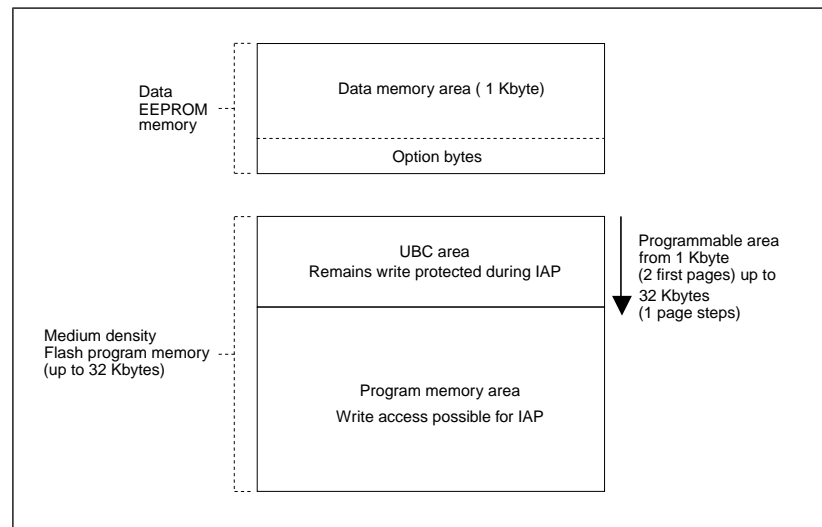

Read-out protection (ROP)

The read-out protection blocks reading and writing the Flash program memory and data EEPROM memory in ICP mode (and debug mode). Once the read-out protection is activated, any attempt to toggle its status triggers a global erase of the program and data memory. Even if no protection can be considered as totally unbreakable, the feature provides a very high level of protection for a general purpose microcontroller.

4.5 Clock controller

The clock controller distributes the system clock (f_{MASTER}) coming from different oscillators to the core and the peripherals. It also manages clock gating for low power modes and ensures clock robustness.

Features

- **Clock prescaler:** To get the best compromise between speed and current consumption the clock frequency to the CPU and peripherals can be adjusted by a programmable prescaler.
- **Safe clock switching:** Clock sources can be changed safely on the fly in run mode through a configuration register. The clock signal is not switched until the new clock source is ready. The design guarantees glitch-free switching.
- **Clock management:** To reduce power consumption, the clock controller can stop the clock to the core, individual peripherals or memory.
- **Master clock sources:** Four different clock sources can be used to drive the master clock:
 - 1-16 MHz high-speed external crystal (HSE)
 - Up to 16 MHz high-speed user-external clock (HSE user-ext)

- 16 MHz high-speed internal RC oscillator (HSI)
- 128 kHz low-speed internal RC (LSI)
- **Startup clock:** After reset, the microcontroller restarts by default with an internal 2 MHz clock (HSI/8). The prescaler ratio and clock source can be changed by the application program as soon as the code execution starts.
- **Clock security system (CSS):** This feature can be enabled by software. If an HSE clock failure occurs, the internal RC (16 MHz/8) is automatically selected by the CSS and an interrupt can optionally be generated.
- **Configurable main clock output (CCO):** This outputs an external clock for use by the application.

Table 3: Peripheral clock gating bit assignments in CLK_PCKENR1/2 registers

Bit	Peripheral clock	Bit	Peripheral clock	Bit	Peripheral clock	Bit	Peripheral clock
PCKEN1 7	TIM1	PCKEN1 3	UART2	PCKEN2 7	Reserved	PCKEN2 3	ADC
PCKEN1 6	TIM3	PCKEN1 2	Reserved	PCKEN2 6	Reserved	PCKEN2 2	AWU
PCKEN1 5	TIM2	PCKEN1 1	SPI	PCKEN2 5	Reserved	PCKEN2 1	Reserved
PCKEN1 4	TIM4	PCKEN1 0	I ² C	PCKEN2 4	Reserved	PCKEN2 0	Reserved

4.6 Power management

For efficient power management, the application can be put in one of four different low-power modes. You can configure each mode to obtain the best compromise between lowest power consumption, fastest start-up time and available wakeup sources.

- **Wait mode:** In this mode, the CPU is stopped, but peripherals are kept running. The wakeup is performed by an internal or external interrupt or reset.
- **Active halt mode with regulator on:** In this mode, the CPU and peripheral clocks are stopped. An internal wakeup is generated at programmable intervals by the auto wake up unit (AWU). The main voltage regulator is kept powered on, so current consumption is higher than in active halt mode with regulator off, but the wakeup time is faster. Wakeup is triggered by the internal AWU interrupt, external interrupt or reset.
- **Active halt mode with regulator off:** This mode is the same as active halt with regulator on, except that the main voltage regulator is powered off, so the wake up time is slower.
- **Halt mode:** In this mode the microcontroller uses the least power. The CPU and peripheral clocks are stopped, the main voltage regulator is powered off. Wakeup is triggered by external event or reset.

4.7 Watchdog timers

The watchdog system is based on two independent timers providing maximum security to the applications.

Activation of the watchdog timers is controlled by option bytes or by software. Once activated, the watchdogs cannot be disabled by the user program without performing a reset.

Window watchdog timer

The window watchdog is used to detect the occurrence of a software fault, usually generated by external interferences or by unexpected logical conditions, which cause the application program to abandon its normal sequence.

The window function can be used to trim the watchdog behavior to match the application perfectly.

The application software must refresh the counter before time-out and during a limited time window.

A reset is generated in two situations:

1. Timeout: At 16 MHz CPU clock the time-out period can be adjusted between 75 μ s up to 64 ms.
2. Refresh out of window: The downcounter is refreshed before its value is lower than the one stored in the window register.

Independent watchdog timer

The independent watchdog peripheral can be used to resolve processor malfunctions due to hardware or software failures.

It is clocked by the 128 kHz LSI internal RC clock source, and thus stays active even in case of a CPU clock failure

The IWDG time base spans from 60 μ s to 1 s.

4.8 Auto wakeup counter

- Used for auto wakeup from active halt mode
- Clock source: Internal 128 kHz internal low frequency RC oscillator or external clock
- LSI clock can be internally connected to TIM3 input capture channel 1 for calibration

4.9 Beeper

The beeper function outputs a signal on the BEEP pin for sound generation. The signal is in the range of 1, 2 or 4 kHz.

The beeper output port is only available through the alternate function remap option bit AFR7.

4.10 TIM1 - 16-bit advanced control timer

This is a high-end timer designed for a wide range of control applications. With its complementary outputs, dead-time control and center-aligned PWM capability, the field of applications is extended to motor control, lighting and half-bridge driver

- 16-bit up, down and up/down autoreload counter with 16-bit prescaler
- Four independent capture/compare channels (CAPCOM) configurable as input capture, output compare, PWM generation (edge and center aligned mode) and single pulse mode output
- Synchronization module to control the timer with external signals
- Break input to force the timer outputs into a defined state
- Three complementary outputs with adjustable dead time
- Encoder mode
- Interrupt sources: 3 x input capture/output compare, 1 x overflow/update, 1 x break

4.11 TIM2, TIM3 - 16-bit general purpose timers

- 16-bit autoreload (AR) up-counter
- 15-bit prescaler adjustable to fixed power of 2 ratios 1...32768
- Timers with 3 or 2 individually configurable capture/compare channels
- PWM mode
- Interrupt sources: 2 or 3 x input capture/output compare, 1 x overflow/update

4.12 TIM4 - 8-bit basic timer

- 8-bit autoreload, adjustable prescaler ratio to any power of 2 from 1 to 128
- Clock source: CPU clock
- Interrupt source: 1 x overflow/update

Table 4: TIM timer features

Timer	Counter size (bits)	Prescaler	Counting mode	CAPCOM channels	Complem. outputs	Ext. trigger	Timer synchronization/chaining
TIM1	16	Any integer from 1 to 65536	Up/down	4	3	Yes	No
TIM2	16	Any power of 2 from 1 to 32768	Up	3	0	No	
TIM3	16	Any power of 2 from 1 to 32768	Up	2	0	No	

Timer	Counter size (bits)	Prescaler	Counting mode	CAPCOM channels	Complem. outputs	Ext. trigger	Timer synchronization/chaining
TIM4	8	Any power of 2 from 1 to 128	Up	0	0	No	

4.13 Analog-to-digital converter (ADC1)

The STM8S105xx products contain a 10-bit successive approximation A/D converter (ADC1) with up to 10 multiplexed input channels and the following main features:

- Input voltage range: 0 to V_{DDA}
- Conversion time: 14 clock cycles
- Single and continuous and buffered continuous conversion modes
- Buffer size ($n \times 10$ bits) where n = number of input channels
- Scan mode for single and continuous conversion of a sequence of channels
- Analog watchdog capability with programmable upper and lower thresholds
- Analog watchdog interrupt
- External trigger input
- Trigger from TIM1 TRGO
- End of conversion (EOC) interrupt

 **Note:** Additional AIN12 analog input is not selectable in ADC scan mode or with analog watchdog. Values converted from AIN12 are stored only into the ADC_DRH/ADC_DRL registers.

4.14 Communication interfaces

The following communication interfaces are implemented:

- UART2: Full feature UART, synchronous mode, SPI master mode, Smartcard mode, IrDA mode, LIN2.1 master/slave capability
- SPI : Full and half-duplex, 8 Mbit/s
- I²C: Up to 400 Kbit/s

4.14.1 UART2

Main features

- One Mbit/s full duplex SCI
- SPI emulation
- High precision baud rate generator
- Smartcard emulation
- IrDA SIR encoder decoder

- LIN master mode
- LIN slave mode

Asynchronous communication (UART mode)

- Full duplex communication - NRZ standard format (mark/space)
- Programmable transmit and receive baud rates up to 1 Mbit/s ($f_{\text{CPU}}/16$) and capable of following any standard baud rate regardless of the input frequency
- Separate enable bits for transmitter and receiver
- Two receiver wakeup modes:
 - Address bit (MSB)
 - Idle line (interrupt)
- Transmission error detection with interrupt generation
- Parity control

Synchronous communication

- Full duplex synchronous transfers
- SPI master operation
- 8-bit data communication
- Maximum speed: 1 Mbit/s at 16 MHz ($f_{\text{CPU}}/16$)

LIN master mode

- Emission: Generates 13-bit synch break frame
- Reception: Detects 11-bit break frame

LIN slave mode

- Autonomous header handling - one single interrupt per valid message header
- Automatic baud rate synchronization - maximum tolerated initial clock deviation $\pm 15\%$
- Synch delimiter checking
- 11-bit LIN synch break detection - break detection always active
- Parity check on the LIN identifier field
- LIN error management
- Hot plugging support

4.14.2 SPI

- Maximum speed: 8 Mbit/s ($f_{\text{MASTER}}/2$) both for master and slave
- Full duplex synchronous transfers
- Simplex synchronous transfers on two lines with a possible bidirectional data line
- Master or slave operation - selectable by hardware or software
- CRC calculation
- 1 byte Tx and Rx buffer
- Slave/master selection input pin

4.14.3 I²C

- I²C master features:
 - Clock generation
 - Start and stop generation
- I²C slave features:
 - Programmable I²C address detection
 - Stop bit detection
- Generation and detection of 7-bit/10-bit addressing and general call
- Supports different communication speeds:
 - Standard speed (up to 100 kHz)
 - Fast speed (up to 400 kHz)

5 Pinout and pin description

Table 5: Legend/abbreviations for pinout tables

Type	I= Input, O = Output, S = Power supply	
Level	Input	CM = CMOS
	Output	HS = High sink
Output speed	<p>O1 = Slow (up to 2 MHz)</p> <p>O2 = Fast (up to 10 MHz)</p> <p>O3 = Fast/slow programmability with slow as default state after reset</p> <p>O4 = Fast/slow programmability with fast as default state after reset</p>	
Port and control configuration	Input	float = floating, wpu = weak pull-up
	Output	T = True open drain, OD = Open drain, PP = Push pull
Reset state	<p>Bold X (pin state after internal reset release).</p> <p>Unless otherwise specified, the pin state is the same during the reset phase and after the internal reset release.</p>	

5.1 STM8S105 pinouts and pin description

Figure 3: LQFP 48-pin pinout

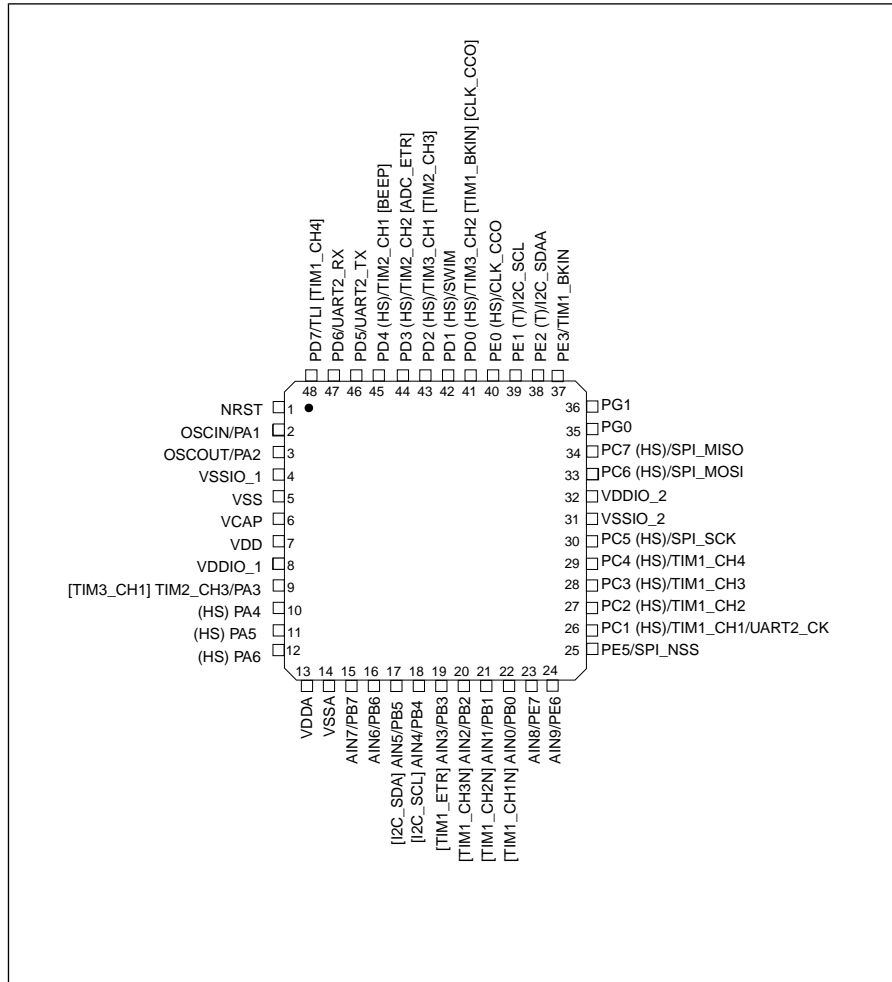

1. (HS) high sink capability.
2. (T) True open drain (P-buffer and protection diode to V_{DD} not implemented).
3. [] alternate function remapping option (If the same alternate function is shown twice, it indicates an exclusive choice not a duplication of the function).

Figure 4: LQFP 44-pin pinout

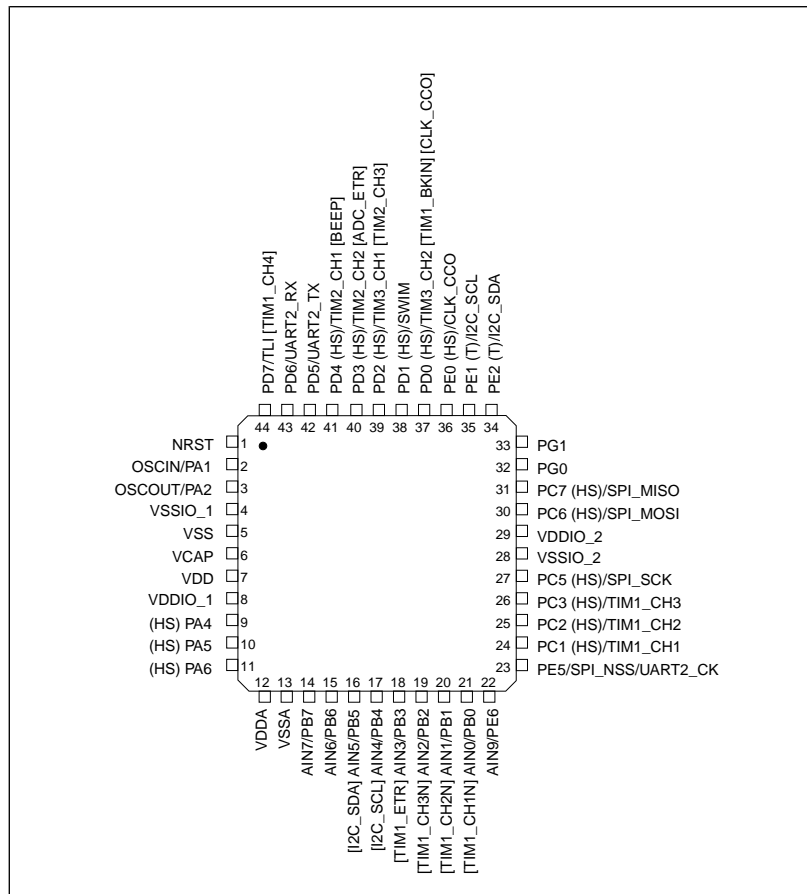

1. (HS) high sink capability.
2. (T) True open drain (P-buffer and protection diode to V_{DD} not implemented).
3. [] alternate function remapping option (If the same alternate function is shown twice, it indicates an exclusive choice not a duplication of the function).

Figure 5: LQFP/UFQFPN 32-pin pinout

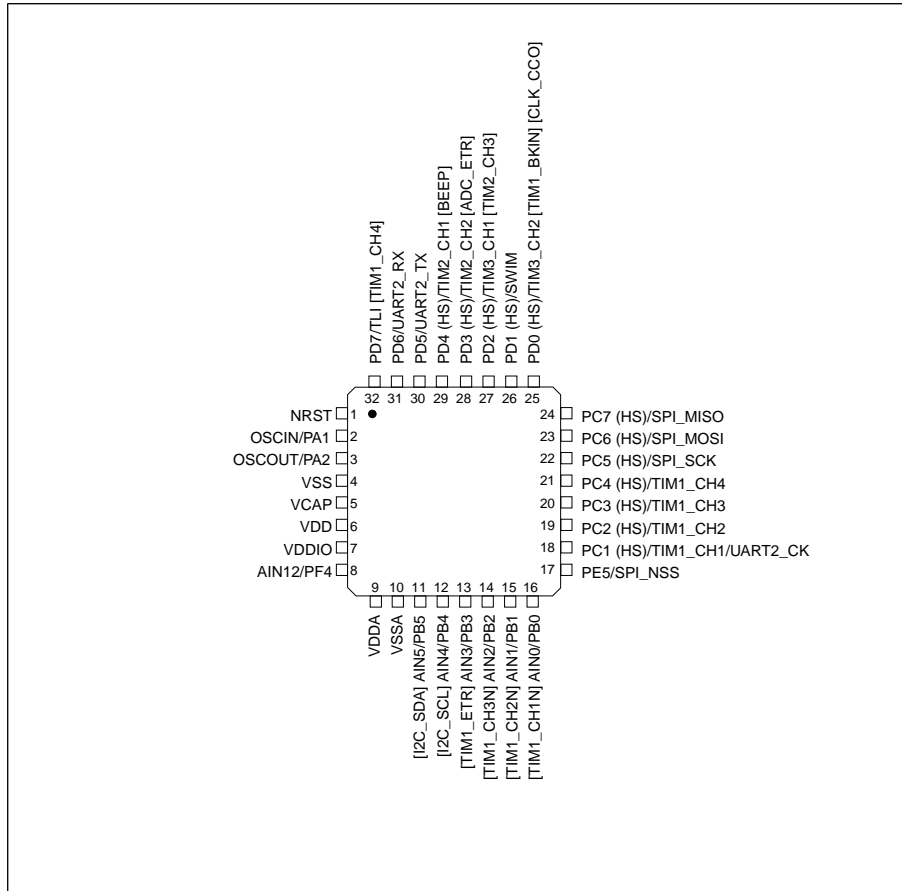

1. (HS) high sink capability.
2. [] alternate function remapping option (If the same alternate function is shown twice, it indicates an exclusive choice not a duplication of the function).

Figure 6: SDIP 32-pin pinout

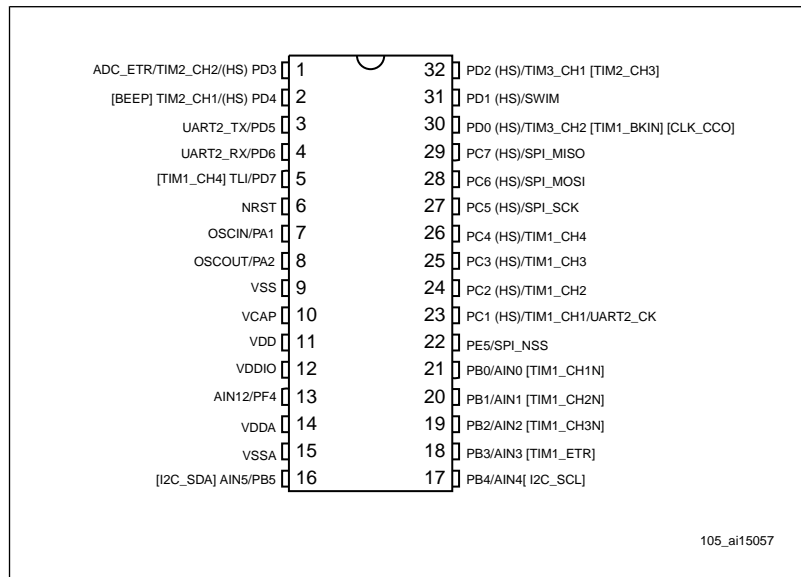

1. (HS) high sink capability.
2. (T) True open drain (P-buffer and protection diode to V_{DD} not implemented).
3. [] alternate function remapping option (If the same alternate function is shown twice, it indicates an exclusive choice not a duplication of the function).

Table 6: Pin description for STM8S105 microcontrollers

Pin number				Pin name	Type	Input			Output				Main function (after reset)	Default alternate function	Alternate function after remap [option bit]
LQFP48	LQFP44	LQFP32/ UFQFPN32	SDIP32			floating	wpu	Ext. interrupt	High sink	Speed	OD	PP			
1	1	1	6	NRST	I/O		X						Reset		
2	2	2	7	PA1/ OSC IN	I/O	X	X			O1	X	X	Port A1	Resonator/ crystal in	
3	3	3	8	PA2/ OSC OUT	I/O	X	X	X		O1	X	X	Port A2	Resonator/ crystal out	
4	4	-	-	VSSIO_1	S								I/O ground		
5	5	4	9	VSS	S								Digital ground		
6	6	5	10	VCAP	S								1.8 V regulator capacitor		
7	7	6	11	VDD	S								Digital power supply		
8	8	7	12	VDDIO_1	S								I/O power supply		

Pin number				Pin name	Type	Input			Output				Main function (after reset)	Default alternate function	Alternate function after remap [option bit]
LQFP48	LQFP44	LQFP32/ UFQFPN32	SDIP32			floating	wpu	Ext. interrupt	High sink	Speed	OD	PP			
9	-	-	-	PA3/ TIM2 _CH3 [TIM3 _CH1]	I/O	X	X	X		O1	X	X	Port A3	Timer 2 - channel 3	TIM3_CH1 [AFR1]
10	9	-	-	PA4	I/O	X	X	X	HS	O3	X	X	Port A4		
11	10	-	-	PA5	I/O	X	X	X	HS	O3	X	X	Port A5		
12	11	-	-	PA6	I/O	X	X	X	HS	O3	X	X	Port A6		
-	-	8	13	PF4/ AJN12 (1)	I/O	X	X			O1	X	X	Port F4	Analog input 12 (2)	
13	12	9	14	VDDA	S								Analog power supply		
14	13	10	15	VSSA	S								Analog ground		
15	14	-	-	PB7/ AIN7	I/O	X	X	X		O1	X	X	Port B7	Analog input 7	
16	15	-	-	PB6/ AIN6	I/O	X	X	X		O1	X	X	Port B6	Analog input 6	
17	16	11	16	PB5/ AJN5 [I ² C _SDA]	I/O	X	X	X		O1	X	X	Port B5	Analog input 5	I ² C_SDA [AFR6]
18	17	12	17	PB4/ AJN4 [I ² C _SCL]	I/O	X	X	X		O1	X	X	Port B4	Analog input 4	I ² C_SCL [AFR6]
19	18	13	18	PB3/ AIN3 [TIM1_ ETR]	I/O	X	X	X		O1	X	X	Port B3	Analog input 3	TIM1_ETR [AFR5]
20	19	14	19	PB2/ AIN2 [TIM1_ CH3N]	I/O	X	X	X		O1	X	X	Port B2	Analog input 2	TIM1_CH3N [AFR5]
21	20	15	20	PB1/ AIN1 [TIM1_ CH2N]	I/O	X	X	X		O1	X	X	Port B1	Analog input 1	TIM1_CH2N [AFR5]
22	21	16	21	PB0/ AIN0 [TIM1_ CH1N]	I/O	X	X	X		O1	X	X	Port B0	Analog input 0	TIM1_CH1N [AFR5]
23	-	-	-	PE7/ AIN8	I/O	X	X	X		O1	X	X	Port E7	Analog input 8	

Pin number				Pin name	Type	Input			Output				Main function (after reset)	Default alternate function	Alternate function after remap [option bit]
LQFP48	LQFP44	LQFP32/ UFQFPN32	SDIP32			floating	wpu	Ext. interrupt	High sink	Speed	OD	PP			
24	22	-	-	PE6/ AIN9	I/O	X	X	X		O1	X	X	Port E6	Analog input 9 ⁽³⁾	
25	23	17	22	PE5/SPI_ NSS	I/O	X	X	X		O1	X	X	Port E5	SPI master/slave select	
26	24	18	23	PC1/ TIM1_ CH1/ UART2_CK	I/O	X	X	X	HS	O3	X	X	Port C1	Timer 1 - channel 1/ UART2 synchronous clock	
27	25	19	24	PC2/ TIM1_ CH2	I/O	X	X	X	HS	O3	X	X	Port C2	Timer 1 - channel 2	
28	26	20	25	PC3/ TIM1_ CH3	I/O	X	X	X	HS	O3	X	X	Port C3	Timer 1 - channel 3	
29	-	21	26	PC4/ TIM1_ CH4	I/O	X	X	X	HS	O3	X	X	Port C4	Timer 1 - channel 4	
30	27	22	27	PC5/ SPI_ SCK	I/O	X	X	X	HS	O3	X	X	Port C5	SPI clock	
31	28	-	-	VSSIO_2	S								I/O ground		
32	29	-	-	VDDIO_2	S								I/O power supply		
33	30	23	28	PC6/ SPI_ MOSI	I/O	X	X	X	HS	O3	X	X	Port C6	SPI master out/slave in	
34	31	24	29	PC7/ SPI_ MISO	I/O	X	X	X	HS	O3	X	X	Port C7	SPI master in/ slave out	
35	32	-	-	PG0	I/O	X	X			O1	X	X	Port G0		
36	33	-	-	PG1	I/O	X	X			O1	X	X	Port G1		
37	-	-	-	PE3/ TIM1_ BKIN	I/O	X	X	X		O1	X	X	Port E3	Timer 1 - break input	
38	34	-	-	PE2/ I ² C_ SDA	I/O	X		X		O1	T ⁽⁴⁾		Port E2	I ² C data	
39	35	-	-	PE1/ I ² C_ SCL	I/O	X		X		O1	T ⁽⁴⁾		Port E1	I ² C clock	
40	36	-	-	PE0/ CLK_ CCO	I/O	X	X	X	HS	O3	X	X	Port E0	Configurable clock output	

Pin number				Pin name	Type	Input			Output				Main function (after reset)	Default alternate function	Alternate function after remap [option bit]
LQFP48	LQFP44	LQFP32/ UFQFPN32	SDIP32			floating	wpu	Ext. interrupt	High sink	Speed	OD	PP			
41	37	25	30	PD0/ TIM3_ CH2 [TIM1_ BKIN] [CLK_ CCO]	I/O	X	X	X	HS	O3	X	X	Port D0	Timer 3 - channel 2	TIM1_ BKIN [AFR3]/ CLK_ CCO [AFR2]
42	38	26	31	PD1/ SWIM ⁽⁵⁾	I/O	X	X	X	HS	O4	X	X	Port D1	SWIM data interface	
43	39	27	32	PD2/ TIM3_ CH1 [TIM2_ CH3]	I/O	X	X	X	HS	O3	X	X	Port D2	Timer 3 - channel 1	TIM2_ CH3 [AFR1]
44	40	28	1	PD3/ TIM2_ CH2 [ADC_ ETR]	I/O	X	X	X	HS	O3	X	X	Port D3	Timer 2 - channel 2	ADC_ ETR [AFR0]
45	41	29	2	PD4/ TIM2_ CH1 [BEEP]	I/O	X	X	X	HS	O3	X	X	Port D4	Timer 2 - channel 1	BEEP output [AFR7]
46	42	30	3	PD5/ UART2_ TX	I/O	X	X	X		O1	X	X	Port D5	UART2 data transmit	
47	43	31	4	PD6/ UART2_ RX	I/O	X	X	X		O1	X	X	Port D6	UART2 data receive	
48	44	32	5	PD7/ TLI [TIM1_ CH4]	I/O	X	X	X		O1	X	X	Port D7	Top level interrupt	TIM1_ CH4 [AFR4]

- (1) A pull-up is applied to PF4 during the reset phase. This pin is input floating after reset release.
- (2) AIN12 is not selectable in ADC scan mode or with analog watchdog.
- (3) In 44-pin package, AIN9 cannot be used by ADC scan mode.
- (4) In the open-drain output column, 'T' defines a true open-drain I/O (P-buffer, weak pull-up and protection diode to V_{DD} are not implemented).
- (5) The PD1 pin is in input pull-up during the reset phase and after internal reset release.

5.1.1 Alternate function remapping

As shown in the rightmost column of the pin description table, some alternate functions can be remapped at different I/O ports by programming one of eight AFR (alternate function remap) option bits. When the remapping option is active, the default alternate function is no longer available.

To use an alternate function, the corresponding peripheral must be enabled in the peripheral registers.

Alternate function remapping does not effect GPIO capabilities of the I/O ports (see the GPIO section of the family reference manual, RM0016).

6 Memory and register map

6.1 Memory map

Figure 7: Memory map

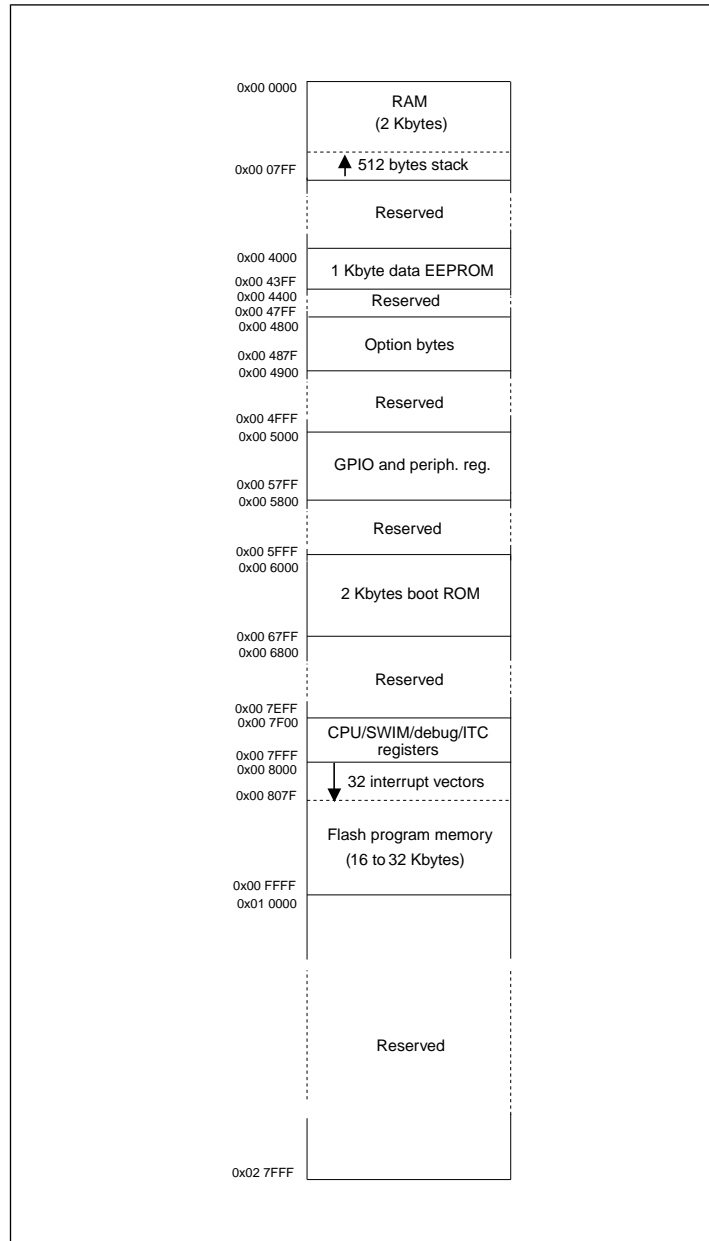

The following table lists the boundary addresses for each memory size. The top of the stack is at the RAM end address in each case.

Table 7: Flash, Data EEPROM and RAM boundary addresses

Memory area	Size (bytes)	Start address	End address
Flash program memory	32K	0x00 8000	0x00 FFFF
	16K	0x00 8000	0x00 BFFF
RAM	2K	0x00 0000	0x00 07FF
Data EEPROM	1024	0x00 4000	0x00 43FF

6.2 Register map

6.2.1 I/O port hardware register map

Table 8: I/O port hardware register map

Address	Block	Register label	Register name	Reset status
0x00 5000	Port A	PA_ODR	Port A data output latch register	0x00
0x00 5001		PA_IDR	Port A input pin value register	0xFF
0x00 5002		PA_DDR	Port A data direction register	0x00
0x00 5003		PA_CR1	Port A control register 1	0x00
0x00 5004		PA_CR2	Port A control register 2	0x00
0x00 5005	Port B	PB_ODR	Port B data output latch register	0x00
0x00 5006		PB_IDR	Port B input pin value register	0xFF
0x00 5007		PB_DDR	Port B data direction register	0x00
0x00 5008		PB_CR1	Port B control register 1	0x00
0x00 5009		PB_CR2	Port B control register 2	0x00

Address	Block	Register label	Register name	Reset status
0x00 500A	Port C	PC_ODR	Port C data output latch register	0x00
0x00 500B		PC_IDR	Port C input pin value register	0xFF
0x00 500C		PC_DDR	Port C data direction register	0x00
0x00 500D		PC_CR1	Port C control register 1	0x00
0x00 500E		PC_CR2	Port C control register 2	0x00
0x00 500F	Port D	PD_ODR	Port D data output latch register	0x00
0x00 5010		PD_IDR	Port D input pin value register	0xFF
0x00 5011		PD_DDR	Port D data direction register	0x00
0x00 5012		PD_CR1	Port D control register 1	0x02
0x00 5013		PD_CR2	Port D control register 2	0x00
0x00 5014	Port E	PE_ODR	Port E data output latch register	0x00
0x00 5015		PE_IDR	Port E input pin value register	0xFF
0x00 5016		PE_DDR	Port E data direction register	0x00
0x00 5017		PE_CR1	Port E control register 1	0x00
0x00 5018		PE_CR2	Port E control register 2	0x00
0x00 5019	Port F	PF_ODR	Port F data output latch register	0x00
0x00 501A		PF_IDR	Port F input pin value register	0xFF
0x00 501B		PF_DDR	Port F data direction register	0x00
0x00 501C		PF_CR1	Port F control register 1	0x00

Address	Block	Register label	Register name	Reset status
0x00 501D		PF_CR2	Port F control register 2	0x00
0x00 501E	Port G	PG_ODR	Port G data output latch register	0x00
0x00 501F		PG_IDR	Port G input pin value register	0xFF
0x00 5020		PG_DDR	Port G data direction register	0x00
0x00 5021		PG_CR1	Port G control register 1	0x00
0x00 5022		PG_CR2	Port G control register 2	0x00
0x00 5023		Port H	PH_ODR	Port H data output latch register
0x00 5024	PH_IDR		Port H input pin value register	0xFF
0x00 5025	PH_DDR		Port H data direction register	0x00
0x00 5026	PH_CR1		Port H control register 1	0x00
0x00 5027	PH_CR2		Port H control register 2	0x00
0x00 5028	Port I	PI_ODR	Port I data output latch register	0x00
0x00 5029		PI_IDR	Port I input pin value register	0xFF
0x00 502A		PI_DDR	Port I data direction register	0x00
0x00 502B		PI_CR1	Port I control register 1	0x00
0x00 502C		PI_CR2	Port I control register 2	0x00

6.2.2 General hardware register map

Table 9: General hardware register map

Address	Block	Register label	Register name	Reset status
0x00 5050 to 0x00 5059	Reserved area (10 bytes)			
0x00 505A	Flash	FLASH_CR1	Flash control register 1	0x00
0x00 505B		FLASH_CR2	Flash control register 2	0x00
0x00 505C		FLASH_NCR2	Flash complementary control register 2	0xFF
0x00 505D		FLASH_FPR	Flash protection register	0x00
0x00 505E		FLASH_NFPR	Flash complementary protection register	0xFF
0x00 505F		FLASH_IAPSR	Flash in-application programming status register	0x00
0x00 5060 to 0x00 5061	Reserved area (2 bytes)			
0x00 5062	Flash	FLASH_PUKR	Flash program memory unprotection register	0x00
0x00 5063	Reserved area (1 byte)			
0x00 5064	Flash	FLASH_DUKR	Data EEPROM unprotection register	0x00
0x00 5065 to 0x00 509F	Reserved area (59 bytes)			
0x00 50A0	ITC	EXTI_CR1	External interrupt control register 1	0x00
0x00 50A1		EXTI_CR2	External interrupt control register 2	0x00

Address	Block	Register label	Register name	Reset status
0x00 50A2 to 0x00 50B2	Reserved area (17 bytes)			
0x00 50B3	RST	RST_SR	Reset status register	0xXX ⁽¹⁾
0x00 50B4 to 0x00 50BF	Reserved area (12 bytes)			
0x00 50C0	CLK	CLK_ICKR	Internal clock control register	0x01
0x00 50C1		CLK_ECKR	External clock control register	0x00
0x00 50C2	Reserved area (1 byte)			
0x00 50C3	CLK	CLK_CMSR	Clock master status register	0xE1
0x00 50C4		CLK_SWR	Clock master switch register	0xE1
0x00 50C5		CLK_SWCR	Clock switch control register	0xXX
0x00 50C6		CLK_CKDIVR	Clock divider register	0x18
0x00 50C7		CLK_PCKENR1	Peripheral clock gating register 1	0xFF
0x00 50C8		CLK_CSSR	Clock security system register	0x00
0x00 50C9		CLK_CCOR	Configurable clock control register	0x00
0x00 50CA		CLK_PCKENR2	Peripheral clock gating register 2	0xFF
0x00 50CB		CLK_CANCCR	CAN clock control register	0x00
0x00 50CC		CLK_HSITRIMR	HSI clock calibration trimming register	0x00
0x00 50CD		CLK_SWIMCCR	SWIM clock control register	0bXXXX XXX0

Address	Block	Register label	Register name	Reset status
0x00 50CE to 0x00 50D0	Reserved area (3 bytes)			
0x00 50D1	WWDG	WWDG_CR	WWDG control register	0x7F
0x00 50D2		WWDG_WR	WWDG window register	0x7F
0x00 50D3 to 0x00 50DF	Reserved area (13 bytes)			
0x00 50E0	IWDG	IWDG_KR	IWDG key register	0xFF ⁽²⁾
0x00 50E1		IWDG_PR	IWDG prescaler register	0x00
0x00 50E2		IWDG_RLR	IWDG reload register	0xFF
0x00 50E3 to 0x00 50EF	Reserved area (13 bytes)			
0x00 50F0	AWU	AWU_CSR1	AWU control/ status register 1	0x00
0x00 50F1		AWU_APR	AWU asynchronous prescaler buffer register	0x3F
0x00 50F2		AWU_TBR	AWU timebase selection register	0x00
0x00 50F3	BEEP	BEEP_CSR	BEEP control/ status register	0x1F
0x00 50F4 to 0x00 50FF	Reserved area (12 bytes)			
0x00 5200	SPI	SPI_CR1	SPI control register 1	0x00
0x00 5201		SPI_CR2	SPI control register 2	0x00
0x00 5202		SPI_ICR	SPI interrupt control register	0x00
0x00 5203		SPI_SR	SPI status register	0x02

Address	Block	Register label	Register name	Reset status	
0x00 5204		SPI_DR	SPI data register	0x00	
0x00 5205		SPI_CRCPR	SPI CRC polynomial register	0x07	
0x00 5206		SPI_RXCR	SPI Rx CRC register	0xFF	
0x00 5207		SPI_TXCR	SPI Tx CRC register	0xFF	
0x00 5208 to 0x00 520F	Reserved area (8 bytes)				
0x00 5210	I ² C	I2C_CR1	I ² C control register 1	0x00	
0x00 5211		I2C_CR2	I ² C control register 2	0x00	
0x00 5212		I2C_FREQR	I ² C frequency register	0x00	
0x00 5213		I2C_OARL	I ² C Own address register low	0x00	
0x00 5214		I2C_OARH	I ² C own address register high	0x00	
0x00 5215		Reserved			
0x00 5216		I2C_DR	I ² C data register	0x00	
0x00 5217		I2C_SR1	I ² C status register 1	0x00	
0x00 5218		I2C_SR2	I ² C status register 2	0x00	
0x00 5219		I2C_SR3	I ² C status register 3	0x00	
0x00 521A		I2C_ITR	I ² C interrupt control register	0x00	
0x00 521B		I2C_CCRL	I ² C clock control register low	0x00	
0x00 521C		I2C_CCRH	I ² C clock control register high	0x00	
0x00 521D		I2C_TRISER	I ² C TRISE register	0x02	

Address	Block	Register label	Register name	Reset status
0x00 521E		I2C_PECR	I ² C packet error checking register	0x00
0x00 521F to 0x00 522F	Reserved area (17 bytes)			
0x00 5230 to 0x00 523F	Reserved area (6 bytes)			
0x00 5240	UART2	UART2_SR	UART2 status register	0xC0
0x00 5241		UART2_DR	UART2 data register	0xFF
0x00 5242		UART2_BRR1	UART2 baud rate register 1	0x00
0x00 5243		UART2_BRR2	UART2 baud rate register 2	0x00
0x00 5244		UART2_CR1	UART2 control register 1	0x00
0x00 5245		UART2_CR2	UART2 control register 2	0x00
0x00 5246		UART2_CR3	UART2 control register 3	0x00
0x00 5247		UART2_CR4	UART2 control register 4	0x00
0x00 5248		UART2_CR5	UART2 control register 5	0x00
0x00 5249		UART2_CR6	UART2 control register 6	0x00
0x00 524A		UART2_GTR	UART2 guard time register	0x00
0x00 524B		UART2_PSCR	UART2 prescaler register	0x00
0x00 524C to 0x00 524F		Reserved area (4 bytes)		
0x00 5250	TIM1	TIM1_CR1	TIM1 control register 1	0x00
0x00 5251		TIM1_CR2	TIM1 control register 2	0x00

Address	Block	Register label	Register name	Reset status
0x00 5252		TIM1_SMCR	TIM1 slave mode control register	0x00
0x00 5253		TIM1_ETR	TIM1 external trigger register	0x00
0x00 5254		TIM1_IER	TIM1 interrupt enable register	0x00
0x00 5255		TIM1_SR1	TIM1 status register 1	0x00
0x00 5256		TIM1_SR2	TIM1 status register 2	0x00
0x00 5257		TIM1_EGR	TIM1 event generation register	0x00
0x00 5258		TIM1_CCMR1	TIM1 capture/ compare mode register 1	0x00
0x00 5259		TIM1_CCMR2	TIM1 capture/compare mode register 2	0x00
0x00 525A		TIM1_CCMR3	TIM1 capture/ compare mode register 3	0x00
0x00 525B		TIM1_CCMR4	TIM1 capture/compare mode register 4	0x00
0x00 525C		TIM1_CCER1	TIM1 capture/ compare enable register 1	0x00
0x00 525D		TIM1_CCER2	TIM1 capture/compare enable register 2	0x00
0x00 525E		TIM1_CNTRH	TIM1 counter high	0x00
0x00 525F		TIM1_CNTRL	TIM1 counter low	0x00
0x00 5260		TIM1_PSCRH	TIM1 prescaler register high	0x00
0x00 5261		TIM1_PSCRL	TIM1 prescaler register low	0x00

Address	Block	Register label	Register name	Reset status
0x00 5262		TIM1_ARRH	TIM1 auto-reload register high	0xFF
0x00 5263		TIM1_ARRL	TIM1 auto-reload register low	0xFF
0x00 5264		TIM1_RCR	TIM1 repetition counter register	0x00
0x00 5265		TIM1_CCR1H	TIM1 capture/ compare register 1 high	0x00
0x00 5266		TIM1_CCR1L	TIM1 capture/ compare register 1 low	0x00
0x00 5267		TIM1_CCR2H	TIM1 capture/ compare register 2 high	0x00
0x00 5268		TIM1_CCR2L	TIM1 capture/ compare register 2 low	0x00
0x00 5269		TIM1_CCR3H	TIM1 capture/ compare register 3 high	0x00
0x00 526A		TIM1_CCR3L	TIM1 capture/ compare register 3 low	0x00
0x00 526B		TIM1_CCR4H	TIM1 capture/ compare register 4 high	0x00
0x00 526C		TIM1_CCR4L	TIM1 capture/ compare register 4 low	0x00
0x00 526D		TIM1_BKR	TIM1 break register	0x00
0x00 526E		TIM1_DTR	TIM1 dead-time register	0x00
0x00 526F		TIM1_OISR	TIM1 output idle state register	0x00
0x00 5270 to 0x00 52FF	Reserved area (147 bytes)			
0x00 5300	TIM2	TIM2_CR1	TIM2 control register 1	0x00

Address	Block	Register label	Register name	Reset status
0x00 5301		TIM2_IER	TIM2 interrupt enable register	0x00
0x00 5302		TIM2_SR1	TIM2 status register 1	0x00
0x00 5303		TIM2_SR2	TIM2 status register 2	0x00
0x00 5304		TIM2_EGR	TIM2 event generation register	0x00
0x00 5305		TIM2_CCMR1	TIM2 capture/ compare mode register 1	0x00
0x00 5306		TIM2_CCMR2	TIM2 capture/ compare mode register 2	0x00
0x00 5307		TIM2_CCMR3	TIM2 capture/ compare mode register 3	0x00
0x00 5308		TIM2_CCER1	TIM2 capture/ compare enable register 1	0x00
0x00 5309		TIM2_CCER2	TIM2 capture/ compare enable register 2	0x00
0x00 530A		TIM2_CNTRH	TIM2 counter high	0x00
0x00 530B		TIM2_CNTRL	TIM2 counter low	0x00
0x00 530C		TIM2_PSCR	TIM2 prescaler register	0x00
0x00 530D		TIM2_ARRH	TIM2 auto-reload register high	0xFF
0x00 530E		TIM2_ARRL	TIM2 auto-reload register low	0xFF
0x00 530F		TIM2_CCR1H	TIM2 capture/ compare register 1 high	0x00
0x00 5310		TIM2_CCR1L	TIM2 capture/ compare register 1 low	0x00

Address	Block	Register label	Register name	Reset status
0x00 5311		TIM2_CCR2H	TIM2 capture/ compare reg. 2 high	0x00
0x00 5312		TIM2_CCR2L	TIM2 capture/ compare register 2 low	0x00
0x00 5313		TIM2_CCR3H	TIM2 capture/ compare register 3 high	0x00
0x00 5314		TIM2_CCR3L	TIM2 capture/ compare register 3 low	0x00
0x00 5315 to 0x00 531F	Reserved area (11 bytes)			
0x00 5320	TIM3	TIM3_CR1	TIM3 control register 1	0x00
0x00 5321		TIM3_IER	TIM3 interrupt enable register	0x00
0x00 5322		TIM3_SR1	TIM3 status register 1	0x00
0x00 5323		TIM3_SR2	TIM3 status register 2	0x00
0x00 5324		TIM3_EGR	TIM3 event generation register	0x00
0x00 5325		TIM3_CCMR1	TIM3 capture/ compare mode register 1	0x00
0x00 5326		TIM3_CCMR2	TIM3 capture/ compare mode register 2	0x00
0x00 5327		TIM3_CCER1	TIM3 capture/ compare enable register 1	0x00
0x00 5328		TIM3_CNTRH	TIM3 counter high	0x00
0x00 5329		TIM3_CNTRL	TIM3 counter low	0x00
0x00 532A		TIM3_PSCR	TIM3 prescaler register	0x00

Address	Block	Register label	Register name	Reset status
0x00 532B		TIM3_ARRH	TIM3 auto-reload register high	0xFF
0x00 532C		TIM3_ARRL	TIM3 auto-reload register low	0xFF
0x00 532D		TIM3_CCR1H	TIM3 capture/ compare register 1 high	0x00
0x00 532E		TIM3_CCR1L	TIM3 capture/ compare register 1 low	0x00
0x00 532F		TIM3_CCR2H	TIM3 capture/ compare register 2 high	0x00
0x00 5330		TIM3_CCR2L	TIM3 capture/ compare register 2 low	0x00
0x00 5331 to 0x00 533F	Reserved area (15 bytes)			
0x00 5340	TIM4	TIM4_CR1	TIM4 control register 1	0x00
0x00 5341		TIM4_IER	TIM4 interrupt enable register	0x00
0x00 5342		TIM4_SR	TIM4 status register	0x00
0x00 5343		TIM4_EGR	TIM4 event generation register	0x00
0x00 5344		TIM4_CNTR	TIM4 counter	0x00
0x00 5345		TIM4_PSCR	TIM4 prescaler register	0x00
0x00 5346		TIM4_ARR	TIM4 auto-reload register	0xFF
0x00 5347 to 0x00 53DF	Reserved area (153 bytes)			
0x00 53E0 to 0x00 53F3	ADC1	ADC_DBxR	ADC data buffer registers	0x00

Address	Block	Register label	Register name	Reset status
0x00 53F4 to 0x00 53FF	Reserved area (12 bytes)			
0x00 5400	ADC1	ADC_CSR	ADC control/ status register	0x00
0x00 5401		ADC_CR1	ADC configuration register 1	0x00
0x00 5402		ADC_CR2	ADC configuration register 2	0x00
0x00 5403		ADC_CR3	ADC configuration register 3	0x00
0x00 5404		ADC_DRH	ADC data register high	0xFF
0x00 5405		ADC_DRL	ADC data register low	0xFF
0x00 5406		ADC_TDRH	ADC Schmitt trigger disable register high	0x00
0x00 5407		ADC_TDRL	ADC Schmitt trigger disable register low	0x00
0x00 5408		ADC_HTRH	ADC high threshold register high	0x03
0x00 5409		ADC_HTRL	ADC high threshold register low	0xFF
0x00 540A		ADC_LTRH	ADC low threshold register high	0x00
0x00 540B		ADC_LTRL	ADC low threshold register low	0x00
0x00 540C		ADC_AWSRH	ADC analog watchdog status register high	0x00
0x00 540D		ADC_AWSRL	ADC analog watchdog status register low	0x00

Address	Block	Register label	Register name	Reset status
0x00 540E		ADC_AWCRH	ADC analog watchdog control register high	0x00
0x00 540F		ADC_AWCRL	ADC analog watchdog control register low	0x00
0x00 5410 to 0x00 57FF	Reserved area (1008 bytes)			

⁽¹⁾ Depends on the previous reset source.

⁽²⁾ Write only register.

6.2.3 CPU/SWIM/debug module/interrupt controller registers

Table 10: CPU/SWIM/debug module/interrupt controller registers

Address	Block	Register label	Register name	Reset status
0x00 7F00	CPU ⁽¹⁾	A	Accumulator	0x00
0x00 7F01		PCE	Program counter extended	0x00
0x00 7F02		PCH	Program counter high	0x00
0x00 7F03		PCL	Program counter low	0x00
0x00 7F04		XH	X index register high	0x00
0x00 7F05		XL	X index register low	0x00
0x00 7F06		YH	Y index register high	0x00
0x00 7F07		YL	Y index register low	0x00
0x00 7F08		SPH	Stack pointer high	0x07
0x00 7F09		SPL	Stack pointer low	0xFF

Address	Block	Register label	Register name	Reset status
0x00 7F0A		CCR	Condition code register	0x28
0x00 7F0B to 0x00 7F5F	Reserved area (85 bytes)			
0x00 7F60	CPU	CFG_GCR	Global configuration register	0x00
0x00 7F70	ITC	ITC_SPR1	Interrupt software priority register 1	0xFF
0x00 7F71		ITC_SPR2	Interrupt software priority register 2	0xFF
0x00 7F72		ITC_SPR3	Interrupt software priority register 3	0xFF
0x00 7F73		ITC_SPR4	Interrupt software priority register 4	0xFF
0x00 7F74		ITC_SPR5	Interrupt software priority register 5	0xFF
0x00 7F75		ITC_SPR6	Interrupt software priority register 6	0xFF
0x00 7F76		ITC_SPR7	Interrupt software priority register 7	0xFF
0x00 7F77		ITC_SPR8	Interrupt software priority register 8	0xFF
0x00 7F78 to 0x00 7F79	Reserved area (2 bytes)			
0x00 7F80	SWIM	SWIM_CSR	SWIM control status register	0x00
0x00 7F81 to 0x00 7F8F	Reserved area (15 bytes)			
0x00 7F90	DM	DM_BK1RE	DM breakpoint 1 register extended byte	0xFF
0x00 7F91		DM_BK1RH	DM breakpoint 1 register high byte	0xFF
0x00 7F92		DM_BK1RL	DM breakpoint 1 register low byte	0xFF

Address	Block	Register label	Register name	Reset status
0x00 7F93		DM_BK2RE	DM breakpoint 2 register extended byte	0xFF
0x00 7F94		DM_BK2RH	DM breakpoint 2 register high byte	0xFF
0x00 7F95		DM_BK2RL	DM breakpoint 2 register low byte	0xFF
0x00 7F96		DM_CR1	DM debug module control register 1	0x00
0x00 7F97		DM_CR2	DM debug module control register 2	0x00
0x00 7F98		DM_CSR1	DM debug module control/status register 1	0x10
0x00 7F99		DM_CSR2	DM debug module control/status register 2	0x00
0x00 7F9A		DM_ENFCTR	DM enable function register	0xFF
0x00 7F9B to 0x00 7F9F	Reserved area (5 bytes)			

⁽¹⁾ Accessible by debug module only

7 Interrupt vector mapping

Table 11: Interrupt mapping

IRQ no.	Source block	Description	Wakeup from halt mode	Wakeup from active-halt mode	Vector address
	RESET	Reset	Yes	Yes	0x00 8000
	TRAP	Software interrupt	-	-	0x00 8004
0	TLI	External top level interrupt	-	-	0x00 8008
1	AWU	Auto wake up from halt	-	Yes	0x00 800C
2	CLK	Clock controller	-	-	0x00 8010
3	EXTI0	Port A external interrupts	Yes ⁽¹⁾	Yes ⁽¹⁾	0x00 8014
4	EXTI1	Port B external interrupts	Yes	Yes	0x00 8018
5	EXTI2	Port C external interrupts	Yes	Yes	0x00 801C
6	EXTI3	Port D external interrupts	Yes	Yes	0x00 8020
7	EXTI4	Port E external interrupts	Yes	Yes	0x00 8024
8					0x00 8028
9		Reserved	-	-	0x00 802C
10	SPI	End of transfer	Yes	Yes	0x00 8030
11	TIM1	TIM1 update/ overflow/ underflow/ trigger/ break	-	-	0x00 8034
12	TIM1	TIM1 capture/ compare	-	-	0x00 8038
13	TIM2	TIM update/ overflow	-	-	0x00 803C
14	TIM2	TIM capture/ compare	-	-	0x00 8040

IRQ no.	Source block	Description	Wakeup from halt mode	Wakeup from active-halt mode	Vector address
15	TIM3	Update/ overflow	-	-	0x00 8044
16	TIM3	Capture/ compare	-	-	0x00 8048
17		Reserved	-	-	0x00 804C
18		Reserved	-	-	0x00 8050
19	I ² C	I ² C interrupt	Yes	Yes	0x00 8054
20	UART2	Tx complete	-	-	0x00 8058
21	UART2	Receive register DATA FULL	-	-	0x00 805C
22	ADC1	ADC1 end of conversion/ analog watchdog interrupt	-	-	0x00 8060
23	TIM4	TIM update/ overflow	-	-	0x00 8064
24	Flash	EOP/ WR_PG_DIS	-	-	0x00 8068
Reserved					0x00 806C to 0x00 807C

⁽¹⁾ Except PA1

8 Option bytes

Option bytes contain configurations for device hardware features as well as the memory protection of the device. They are stored in a dedicated block of the memory. Except for the ROP (read-out protection) byte, each option byte has to be stored twice, in a regular form (OPTx) and a complemented one (NOPTx) for redundancy.

Option bytes can be modified in ICP mode (via SWIM) by accessing the EEPROM address shown in the table below.

Option bytes can also be modified 'on the fly' by the application in IAP mode, except the ROP option that can only be modified in ICP mode (via SWIM).

Refer to the STM8S Flash programming manual (PM0051) and STM8 SWIM communication protocol and debug module user manual (UM0470) for information on SWIM programming procedures.

Table 12: Option bytes

Addr.	Option name	Option byte no.	Option bits								Factory default setting
			7	6	5	4	3	2	1	0	
0x4800	Read-out protection (ROP)	OPT0	ROP [7:0]								00h
0x4801	User boot code(UBC)	OPT1	UBC [7:0]								00h
0x4802		NOPT1	NUBC [7:0]								FFh
0x4803	Alternate function remapping (AFR)	OPT2	AFR7	AFR6	AFR5	AFR4	AFR3	AFR2	AFR1	AFR0	00h
0x4804		NOPT2	NAFR7	NAFR6	NAFR5	NAFR4	NAFR3	NAFR2	NAFR1	NAFR0	FFh
0x4805h	Miscell. option	OPT3	Reserved			HSI TRIM	LSI_EN	IWDG_HW	WWDG_HW	WWDG_HALT	00h
0x4806		NOPT3	Reserved			NHSI TRIM	NLSI_EN	NIWDG_HW	NWWDG_HW	NWWDG_HALT	FFh
0x4807	Clock option	OPT4	Reserved			EXT CLK	CKAWU_SEL	PRS C1	PRS C0	00h	
0x4808		NOPT4	Reserved			NEXT CLK	NCKA_WUSEL	NPRSC1	NPRSC0	FFh	
0x4809	HSE clock startup	OPT5	HSECNT [7:0]								00h
0x480A		NOPT5	NHSECNT [7:0]								FFh
0x480B	Reserved	OPT6	Reserved								00h

Addr.	Option name	Option byte no.	Option bits								Factory default setting
			7	6	5	4	3	2	1	0	
0x480C		NOPT6	Reserved								FFh
0x480D	Reserved	OPT7	Reserved								00h
0x480E		NOPT7	Reserved								FFh
0x487E	Bootloader	OPTBL	BL[7:0]								00h
0x487F		NOPTBL	NBL[7:0]								FFh

Table 13: Option byte description

Option byte no.	Description
OPT0	<p>ROP[7:0] Memory readout protection (ROP)</p> <p>AAh: Enable readout protection (write access via SWIM protocol)</p> <p><i>Note: Refer to the family reference manual (RM0016) section on Flash/EEPROM memory readout protection for details.</i></p>
OPT1	<p>UBC[7:0] User boot code area</p> <p>0x00: no UBC, no write-protection</p> <p>0x01: Page 0 to 1 defined as UBC, memory write-protected</p> <p>0x02: Page 0 to 3 defined as UBC, memory write-protected</p> <p>0x03: Page 0 to 4 defined as UBC, memory write-protected</p> <p>...</p> <p>0x3E: Pages 0 to 63 defined as UBC, memory write-protected</p> <p>Other values: Reserved</p> <p><i>Note: Refer to the family reference manual (RM0016) section on Flash write protection for more details.</i></p>
OPT2	<p>AFR[7:0]</p> <p>Refer to following table for the alternate function remapping descriptions of bits [7:2].</p>
OPT3	<p>HSITRIM:High speed internal clock trimming register size</p> <p>0: 3-bit trimming supported in CLK_HSITRIMR register</p> <p>1: 4-bit trimming supported in CLK_HSITRIMR register</p>

Option byte no.	Description
	<p>LSI_EN: Low speed internal clock enable 0: LSI clock is not available as CPU clock source 1: LSI clock is available as CPU clock source</p> <p>IWDG_HW: Independent watchdog 0: IWDG Independent watchdog activated by software 1: IWDG Independent watchdog activated by hardware</p> <p>WWDG_HW: Window watchdog activation 0: WWDG window watchdog activated by software 1: WWDG window watchdog activated by hardware</p> <p>WWDG_HALT: Window watchdog reset on halt 0: No reset generated on halt if WWDG active 1: Reset generated on halt if WWDG active</p>
OPT4	<p>EXTCLK: External clock selection 0: External crystal connected to OSCIN/OSCOUT 1: External clock signal on OSCIN</p> <p>CKAWUSEL: Auto wake-up unit/clock 0: LSI clock source selected for AWU 1: HSE clock with prescaler selected as clock source for for AWU</p> <p>PRSC[1:0] AWU clock prescaler 0x: 16 MHz to 128 kHz prescaler 10: 8 MHz to 128 kHz prescaler 11: 4 MHz to 128 kHz prescaler</p>
OPT5	<p>HSECNT[7:0]: HSE crystal oscillator stabilization time 0x00: 2048 HSE cycles 0xB4: 128 HSE cycles 0xD2: 8 HSE cycles 0xE1: 0.5 HSE cycles</p>

Option byte no.	Description
OPT6	Reserved
OPT7	Reserved
OPTBL	<p>BL[7:0] Bootloader option byte</p> <p>For STM8S products, this option is checked by the boot ROM code after reset. Depending on the content of addresses 0x487E, 0x487F, and 0x8000 (reset vector), the CPU jumps to the bootloader or to the reset vector. Refer to the UM0560 (STM8L/S bootloader manual) for more details.</p> <p>For STM8L products, the bootloader option bytes are on addresses 0xXXXX and 0xXXXX+1 (2 bytes). These option bytes control whether the bootloader is active or not. For more details, refer to the UM0560 (STM8L/S bootloader manual) for more details.</p>

Table 14: Description of alternate function remapping bits [7:0] of OPT2

Option byte no.	Description ⁽¹⁾
OPT2	<p>AFR7 Alternate function remapping option 7 0: AFR7 remapping option inactive: Default alternate function⁽²⁾. 1: Port D4 alternate function = BEEP.</p> <p>AFR6 Alternate function remapping option 6 0: AFR6 remapping option inactive: Default alternate functions⁽²⁾. 1: Port B5 alternate function = I²C_SDA; port B4 alternate function = I²C_SCL.</p> <p>AFR5 Alternate function remapping option 5 0: AFR5 remapping option inactive: Default alternate functions⁽²⁾. 1: Port B3 alternate function = TIM1_ETR; port B2 alternate function = TIM1_NCC3; port B1 alternate function = TIM1_CH2N; port B0 alternate function = TIM1_CH1N.</p> <p>AFR4 Alternate function remapping option 4 0: AFR4 remapping option inactive: Default alternate function⁽²⁾. 1: Port D7 alternate function = TIM1_CH4.</p> <p>AFR3 Alternate function remapping option 3 0: AFR3 remapping option inactive: Default alternate function⁽²⁾. 1: Port D0 alternate function = TIM1_BKIN.</p> <p>AFR2 Alternate function remapping option 2</p>

Option byte no.	Description ⁽¹⁾
	<p>0: AFR2 remapping option inactive: Default alternate function⁽²⁾.</p> <p>1: Port D0 alternate function = CLK_CCO. Note: AFR2 option has priority over AFR3 if both are activated.</p> <p>AFR1 Alternate function remapping option 1</p> <p>0: AFR1 remapping option inactive: Default alternate functions⁽²⁾.</p> <p>1: Port A3 alternate function = TIM3_CH1; port D2 alternate function TIM2_CH3.</p> <p>AFR0 Alternate function remapping option 0</p> <p>0: AFR0 remapping option inactive: Default alternate function⁽²⁾.</p> <p>1: Port D3 alternate function = ADC_ETR.</p>

⁽¹⁾ Do not use more than one remapping option in the same port.

⁽²⁾ Refer to pinout description.

9 Unique ID

The devices feature a 96-bit unique device identifier which provides a reference number that is unique for any device and in any context. The 96 bits of the identifier can never be altered by the user.

The unique device identifier can be read in single bytes and may then be concatenated using a custom algorithm.

The unique device identifier is ideally suited:

- For use as serial numbers
- For use as security keys to increase the code security in the program memory while using and combining this unique ID with software cryptographic primitives and protocols before programming the internal memory.
- To activate secure boot processes

Table 15: Unique ID registers (96 bits)

Address	Content description	Unique ID bits							
		7	6	5	4	3	2	1	0
0x48CD	X co-ordinate on the wafer	U_ID[7:0]							
0x48CE		U_ID[15:8]							
0x48CF	Y co-ordinate on the wafer	U_ID[23:16]							
0x48D0		U_ID[31:24]							
0x48D1	Wafer number	U_ID[39:32]							
0x48D2	Lot number	U_ID[47:40]							
0x48D3		U_ID[55:48]							
0x48D4		U_ID[63:56]							
0x48D5		U_ID[71:64]							
0x48D6		U_ID[79:72]							
0x48D7		U_ID[87:80]							
0x48D8		U_ID[95:88]							

10 Electrical characteristics

10.1 Parameter conditions

Unless otherwise specified, all voltages are referred to V_{SS} .

10.1.1 Minimum and maximum values

Unless otherwise specified the minimum and maximum values are guaranteed in the worst conditions of ambient temperature, supply voltage and frequencies by tests in production on 100 % of the devices with an ambient temperature at $T_A = 25\text{ °C}$ and $T_A = T_{Amax}$ (given by the selected temperature range).

Data based on characterization results, design simulation and/or technology characteristics are indicated in the table footnotes and are not tested in production. Based on characterization, the minimum and maximum values refer to sample tests and represent the mean value plus or minus three times the standard deviation (mean $\pm 3 \Sigma$).

10.1.2 Typical values

Unless otherwise specified, typical data are based on $T_A = 25\text{ °C}$, $V_{DD} = 5\text{ V}$. They are given only as design guidelines and are not tested.

Typical ADC accuracy values are determined by characterization of a batch of samples from a standard diffusion lot over the full temperature range, where 95% of the devices have an error less than or equal to the value indicated (mean $\pm 2 \Sigma$).

10.1.3 Typical curves

Unless otherwise specified, all typical curves are given only as design guidelines and are not tested.

10.1.4 Typical current consumption

For typical current consumption measurements, V_{DD} , V_{DDIO} and V_{DDA} are connected together in the configuration shown in the following figure.

Figure 8: Supply current measurement conditions

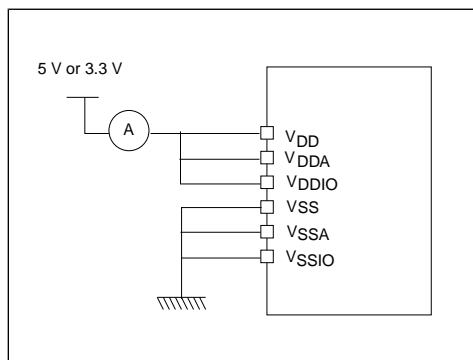

10.1.5 Loading capacitor

The loading conditions used for pin parameter measurement are shown in the following figure.

Figure 9: Pin loading conditions

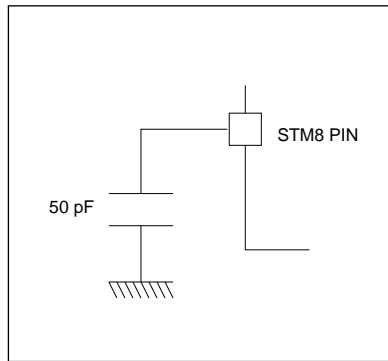

10.1.6 Pin input voltage

The input voltage measurement on a pin of the device is described in the following figure.

Figure 10: Pin input voltage

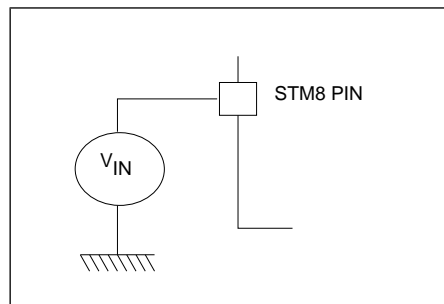

10.2 Absolute maximum ratings

Stresses above those listed as ‘absolute maximum ratings’ may cause permanent damage to the device. This is a stress rating only and functional operation of the device under these conditions is not implied. Exposure to maximum rating conditions for extended periods may affect device reliability.

Table 16: Voltage characteristics

Symbol	Ratings	Min	Max	Unit
$V_{DDx} - V_{SS}$	Supply voltage (including V_{DDA} and V_{DDIO}) ⁽¹⁾	-0.3	6.5	V
V_{IN}	Input voltage on true open drain pins (PE1, PE2) ⁽²⁾	$V_{SS} - 0.3$	6.5	

Symbol	Ratings	Min	Max	Unit
	Input voltage on any other pin ⁽²⁾	$V_{SS} - 0.3$	$V_{DD} + 0.3$	
$ V_{DDx} - V_{DD} $	Variations between different power pins		50	mV
$ V_{SSx} - V_{SS} $	Variations between all the different ground pins		50	
V_{ESD}	Electrostatic discharge voltage	see <i>Absolute maximum ratings (electrical sensitivity)</i>		

⁽¹⁾ All power (V_{DD} , V_{DDIO} , V_{DDA}) and ground (V_{SS} , V_{SSIO} , V_{SSA}) pins must always be connected to the external power supply

⁽²⁾ $I_{INJ(PIN)}$ must never be exceeded. This is implicitly insured if V_{IN} maximum is respected. If V_{IN} maximum cannot be respected, the injection current must be limited externally to the $I_{INJ(PIN)}$ value. A positive injection is induced by $V_{IN} > V_{DD}$ while a negative injection is induced by $V_{IN} < V_{SS}$. For true open-drain pads, there is no positive injection current, and the corresponding V_{IN} maximum must always be respected

Table 17: Current characteristics

Symbol	Ratings	Max. ⁽¹⁾	Unit
I_{VDD}	Total current into V_{DD} power lines (source) ⁽²⁾	60	mA
I_{VSS}	Total current out of V_{SS} ground lines (sink) ⁽²⁾	60	
I_{IO}	Output current sunk by any I/O and control pin	20	
	Output current source by any I/Os and control pin	20	
ΣI_{IO}	Total output current sourced (sum of all I/O and control pins) for devices with two V_{DDIO} pins ⁽³⁾	200	
	Total output current sourced (sum of all I/O and control pins) for devices with one V_{DDIO} pin ⁽³⁾	100	
	Total output current sunk (sum of all I/O and control pins) for devices with two V_{SSIO} pins ⁽³⁾	160	
	Total output current sunk (sum of all I/O and control pins) for devices with one V_{SSIO} pin ⁽³⁾	80	

Symbol	Ratings	Max. ⁽¹⁾	Unit
$I_{INJ(PIN)}$ ^{(4) (5)}	Injected current on NRST pin	±4	
	Injected current on OSCIN pin	±4	
	Injected current on any other pin ⁽⁶⁾	±4	
$\Sigma I_{INJ(PIN)}$ ⁽⁴⁾	Total injected current (sum of all I/O and control pins) ⁽⁶⁾	±20	

(1) Data based on characterization results, not tested in production.

(2) All power (V_{DD} , V_{DDIO} , V_{DDA}) and ground (V_{SS} , V_{SSIO} , V_{SSA}) pins must always be connected to the external supply.

(3) I/O pins used simultaneously for high current source/sink must be uniformly spaced around the package between the V_{DDIO}/V_{SSIO} pins.

(4) $I_{INJ(PIN)}$ must never be exceeded. This is implicitly insured if V_{IN} maximum is respected. If V_{IN} maximum cannot be respected, the injection current must be limited externally to the $I_{INJ(PIN)}$ value. A positive injection is induced by $V_{IN} > V_{DD}$ while a negative injection is induced by $V_{IN} < V_{SS}$. For true open-drain pads, there is no positive injection current, and the corresponding V_{IN} maximum must always be respected

(5) Negative injection disturbs the analog performance of the device. See note in [I2C interface characteristics](#).

(6) When several inputs are submitted to a current injection, the maximum $\Sigma I_{INJ(PIN)}$ is the absolute sum of the positive and negative injected currents (instantaneous values). These results are based on characterization with $\Sigma I_{INJ(PIN)}$ maximum current injection on four I/O port pins of the device.

Table 18: Thermal characteristics

Symbol	Ratings	Value	Unit
T_{STG}	Storage temperature range	-65 to 150	°C
T_J	Maximum junction temperature	150	

10.3 Operating conditions

The device must be used in operating conditions that respect the parameters in the table below. In addition, full account must be taken of all physical capacitor characteristics and tolerances.

Table 19: General operating conditions

Symbol	Parameter	Conditions	Min	Max	Unit
f_{CPU}	Internal CPU clock frequency		0	16	MHz
$V_{\text{DD}}/V_{\text{DD_IO}}$	Standard operating voltage		2.95	5.5	V
$V_{\text{CAP}}^{(1)}$	C_{EXT} : capacitance of external capacitor		470	3300	nF
	ESR of external capacitor	at 1 MHz (2)	-	0.3	Ohm
	ESL of external capacitor		-	15	nH
$P_{\text{D}}^{(3)}$	Power dissipation at $T_{\text{A}} = 85^{\circ}\text{C}$ for suffix 6 or $T_{\text{A}} = 125^{\circ}\text{C}$ for suffix 3	44 and 48-pin devices, with output on eight standard ports, two high sink ports and two open drain ports simultaneously ⁽⁴⁾	-	443	mW
		32-pin package, with output on eight standard ports and two high sink ports simultaneously ⁽⁴⁾	-	360	
T_{A}	Ambient temperature for 6 suffix version	Maximum power dissipation	-40	85	$^{\circ}\text{C}$
	Ambient temperature for 3 suffix version	Maximum power dissipation	-40	125	
T_{J}	Junction temperature range	6 suffix version	-40	105	
		3 suffix version	-40	130	

⁽¹⁾Care should be taken when selecting the capacitor, due to its tolerance, as well as the parameter dependency on temperature, DC bias and frequency in addition to other factors. The parameter maximum value must be respected for the full application range.

(2) This frequency of 1 MHz as a condition for VCAP parameters is given by design of internal regulator.

(3) To calculate $P_{Dmax}(T_A)$, use the formula $P_{Dmax} = (T_{Jmax} - T_A)/\Theta_{JA}$ (see [Thermal characteristics](#)) with the value for T_{Jmax} given in the current table and the value for Θ_{JA} given in [Thermal characteristics](#).

(4) Refer to [Thermal characteristics](#)

Figure 11: f_{CPUmax} versus V_{DD}

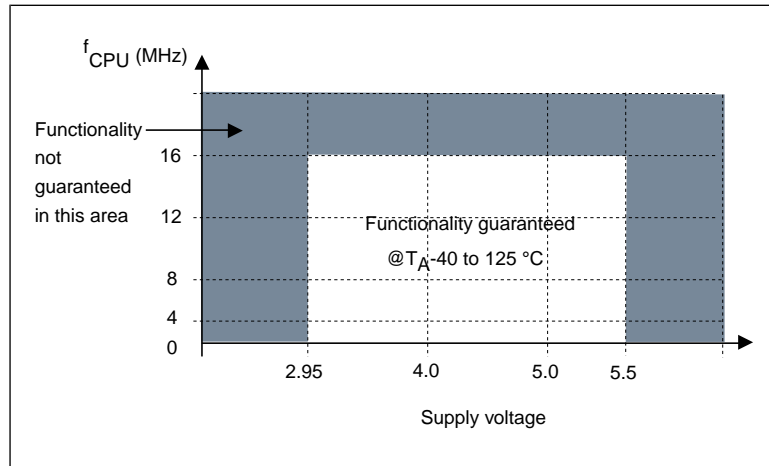

Table 20: Operating conditions at power-up/power-down

Symbol	Parameter	Conditions	Min	Typ	Max	Unit
t_{VDD}	V_{DD} rise time rate		2.0 ⁽¹⁾		∞	$\mu\text{s/V}$
	V_{DD} fall time rate		2.0 ⁽¹⁾		∞	
t_{TEMP}	Reset releasedelay	V_{DD} rising			1.7 ⁽¹⁾	ms
V_{IT+}	Power-on reset threshold		2.65	2.8	2.95	V
V_{IT-}	Brown-out reset threshold		2.58	2.7	2.88	
$V_{HYS(BOR)}$	Brown-out reset hysteresis			70		mV

(1) Guaranteed by design, not tested in production.

10.3.1 VCAP external capacitor

Stabilization for the main regulator is achieved connecting an external capacitor C_{EXT} to the V_{CAP} pin. C_{EXT} is specified in the Operating conditions section. Care should be taken to limit the series inductance to less than 15 nH.

Figure 12: External capacitor C_{EXT}

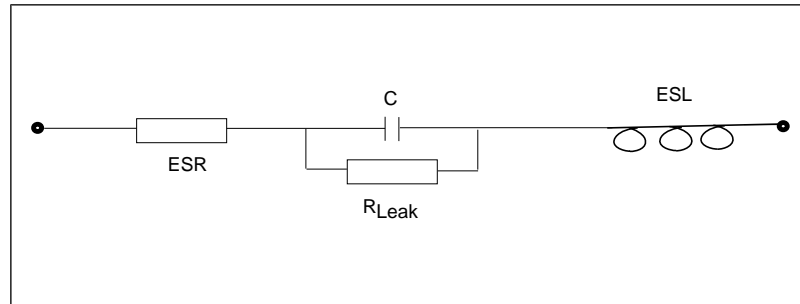

1. ESR is the equivalent series resistance and ESL is the equivalent inductance.

10.3.2 Supply current characteristics

The current consumption is measured as described in [Pin input voltage](#).

10.3.2.1 Total current consumption in run mode

Table 21: Total current consumption with code execution in run mode at $V_{DD} = 5 V$

Symbol	Parameter	Conditions		Typ	Max ⁽¹⁾	Unit
$I_{DD(RUN)}$	Supply current in run mode, code executed from RAM	$f_{CPU} = f_{MASTER} = 16 \text{ MHz}$	HSE crystal osc. (16 MHz)	3.2		mA
			HSE user ext. clock (16 MHz)	2.6	3.2	
			HSI RC osc. (16 MHz)	2.5	3.2	
		$f_{CPU} = f_{MASTER}/128 = 125 \text{ kHz}$	HSE user ext. clock (16 MHz)	1.6	2.2	
			HSI RC osc. (16 MHz)	1.3	2.0	

Symbol	Parameter	Conditions		Typ	Max ⁽¹⁾	Unit
		$f_{CPU} = f_{MASTER}/128 = 15.625 \text{ kHz}$	HSI RC osc. (16 MHz/8)	0.75		
		$f_{CPU} = f_{MASTER} = 128 \text{ kHz}$	LSI RC osc. (128 kHz)	0.55		
$I_{DD(RUN)}$	Supply current in run mode, code executed from Flash	$f_{CPU} = f_{MASTER} = 16 \text{ MHz}$	HSE crystal osc. (16 MHz)	7.7		
			HSE user ext. clock (16 MHz)	7.0	8.0	
			HSI RC osc. (16 MHz)	7.0	8.0	
		$f_{CPU} = f_{MASTER} = 2 \text{ MHz}$	HSI RC osc. (16 MHz/8) ⁽²⁾	1.5		
		$f_{CPU} = f_{MASTER}/128 = 125 \text{ kHz}$	HSI RC osc. (16 MHz)	1.35	2.0	
		$f_{CPU} = f_{MASTER}/128 = 15.625 \text{ kHz}$	HSI RC osc. (16 MHz/8)	0.75		
		$f_{CPU} = f_{MASTER} = 128 \text{ kHz}$	LSI RC osc. (128 kHz)	0.6		

(1) Data based on characterization results, not tested in production.

(2) Default clock configuration measured with all peripherals off.

Table 22: Total current consumption with code execution in run mode at $V_{DD} = 3.3 \text{ V}$

Symbol	Parameter	Conditions		Typ	Max ⁽¹⁾	Unit
$I_{DD(RUN)}$	Supply current in run	$f_{CPU} = f_{MASTER} = 16 \text{ MHz}$	HSE crystal osc. (16 MHz)	2.8		mA

Symbol	Parameter	Conditions	Typ	Max ⁽¹⁾	Unit	
	mode, code executed from RAM		HSE user ext. clock (16 MHz)	2.6	3.2	
			HSI RC osc. (16 MHz)	2.5	3.2	
		$f_{CPU} = f_{MASTER}/128 = 125 \text{ kHz}$		HSE user ext. clock (16 MHz)	1.6	2.2
				HSI RC osc. (16 MHz)	1.3	2.0
		$f_{CPU} = f_{MASTER}/128 = 15.625 \text{ kHz}$		HSI RC osc. (16 MHz/8)	0.75	
		$f_{CPU} = f_{MASTER} = 128 \text{ kHz}$		LSI RC osc. (128 kHz)	0.55	
	Supply current in run mode, code executed from Flash	$f_{CPU} = f_{MASTER} = 16 \text{ MHz}$		HSE crystal osc. (16 MHz)	7.3	
				HSE user ext. clock (16 MHz)	7.0	8.0
				HSI RC osc. (16 MHz)	7.0	8.0
		$f_{CPU} = f_{MASTER} = 2 \text{ MHz}$		HSI RC osc. (16 MHz/8) ⁽²⁾	1.5	
		$f_{CPU} = f_{MASTER}/128 = 125 \text{ kHz}$		HSI RC osc. (16 MHz)	1.35	2.0
		$f_{CPU} = f_{MASTER}/128 = 15.625 \text{ kHz}$		HSI RC osc. (16 MHz/8)	0.75	

Symbol	Parameter	Conditions	Typ	Max ⁽¹⁾	Unit
		$f_{CPU} = f_{MASTER} = 128 \text{ kHz}$ LSI RC osc. (128 kHz)	0.6		

(1) Data based on characterization results, not tested in production.

(2) Default clock configuration measured with all peripherals off.

10.3.2.2 Total current consumption in wait mode

Table 23: Total current consumption in wait mode at $V_{DD} = 5 \text{ V}$

Symbol	Parameter	Conditions	Typ	Max ⁽¹⁾	Unit
$I_{DD(WFI)}$	Supply current in wait mode	$f_{CPU} = f_{MASTER} = 16 \text{ MHz}$ HSE crystal osc. (16 MHz)	2.15		mA
		HSE user ext. clock (16 MHz)	1.55	2.0	
		HSI RC osc. (16 MHz)	1.5	1.9	
		$f_{CPU} = f_{MASTER}/128 = 125 \text{ kHz}$ HSI RC osc. (16 MHz)	1.3		
		$f_{CPU} = f_{MASTER}/128 = 15.625 \text{ kHz}$ HSI RC osc. (16 MHz/8) ⁽²⁾	0.7		
		$f_{CPU} = f_{MASTER} = 128 \text{ kHz}$ LSI RC osc. (128 kHz)	0.5		

(1) Data based on characterization results, not tested in production.

(2) Default clock configuration measured with all peripherals off.

Table 24: Total current consumption in wait mode at $V_{DD} = 3.3\text{ V}$

Symbol	Parameter	Conditions		Typ	Max ⁽¹⁾	Unit
$I_{DD(WFI)}$	Supply current in wait mode	$f_{CPU} = f_{MASTER} = 16\text{ MHz}$	HSE crystal osc. (16 MHz)	1.75		mA
			HSE user ext. clock (16 MHz)	1.55	2.0	
			HSI RC osc. (16 MHz)	1.5	1.9	
		$f_{CPU} = f_{MASTER}/128 = 125\text{ kHz}$	HSI RC osc. (16 MHz)	1.3		
		$f_{CPU} = f_{MASTER}/128 = 15.625\text{ kHz}$	HSI RC osc. (16 MHz/8) ⁽²⁾	0.7		
		$f_{CPU} = f_{MASTER} = 128\text{ kHz}$	LSI RC osc. (128 kHz)	0.5		

⁽¹⁾ Data based on characterization results, not tested in production.

⁽²⁾ Default clock configuration measured with all peripherals off.

10.3.2.3 Total current consumption in active halt mode

Table 25: Total current consumption in active halt mode at $V_{DD} = 5\text{ V}$

Symbol	Parameter	Conditions			Typ	Max at 85 °C ⁽¹⁾	Max at 125 °C ⁽¹⁾	Unit
		Main voltage regulator (MVR) ⁽²⁾	Flash mode ⁽³⁾	Clock source				
$I_{DD(AH)}$	Supply current in active halt mode	On	Operating mode	HSE crystal osc. (16 MHz)	1080			µA
				LSI RC osc.	200	320	400	

Symbol	Parameter	Conditions			Typ	Max at 85 °C ⁽¹⁾	Max at 125 °C ⁽¹⁾	Unit
		Main voltage regulator (MVR) ⁽²⁾	Flash mode ⁽³⁾	Clock source				
				(128 kHz)				
			Power-down mode	HSE crystal osc. (16 MHz)	1030			
				LSI RC osc. (128 kHz)	140	270	350	
		Off	Operating mode	LSI RC osc. (128 kHz)	68	120	220	
			Power-down mode		12	60	150	

⁽¹⁾ Data based on characterization results, not tested in production

⁽²⁾ Configured by the REGAH bit in the CLK_ICKR register.

⁽³⁾ Configured by the AHALT bit in the FLASH_CR1 register.

Table 26: Total current consumption in active halt mode at V_{DD} = 3.3 V

Symbol	Parameter	Conditions			Typ	Max at 85 °C ⁽¹⁾	Max at 125 °C ⁽¹⁾	Unit
		Main voltage regulator (MVR) ⁽²⁾	Flash mode ⁽³⁾	Clock source				
I _{DD(AH)}	Supply current in active halt mode	On	Operating mode	HSE crystal osc. (16 MHz)	680			µA
				LSI RC osc. (128 kHz)	200	320	400	

Symbol	Parameter	Conditions			Typ	Max at 85 °C ⁽¹⁾	Max at 125 °C ⁽¹⁾	Unit
		Main voltage regulator (MVR) ⁽²⁾	Flash mode ⁽³⁾	Clock source				
			Power-down mode	HSE crystal osc. (16 MHz)	630			
				LSI RC osc. (128 kHz)	140	270	350	
		Off	Operating mode	LSI RC osc. (128 kHz)	66	120	220	
			Power-down mode		10	60	150	

⁽¹⁾ Data based on characterization results, not tested in production.

⁽²⁾ Configured by the REGAH bit in the CLK_ICKR register.

⁽³⁾ Configured by the AHALT bit in the FLASH_CR1 register.

10.3.2.4 Total current consumption in halt mode

Table 27: Total current consumption in halt mode at V_{DD} = 5 V

Symbol	Parameter	Conditions	Typ	Max at 85 °C ⁽¹⁾	Max at 125 °C ⁽¹⁾	Unit
I _{DD(H)}	Supply current in halt mode	Flash in operating mode, HSI clock after wakeup	62	90	150	µA
		Flash in powerdown mode, HSI clock after wakeup	6.5	25	80	

⁽¹⁾ Data based on characterization results, not tested in production.

Table 28: Total current consumption in halt mode at $V_{DD} = 3.3\text{ V}$

Symbol	Parameter	Conditions	Typ	Max at 85 °C ⁽¹⁾	Max at 125 °C ⁽¹⁾	Unit
$I_{DD(H)}$	Supply current in halt mode	Flash in operating mode, HSI clock after wakeup	60	90	150	μA
		Flash in powerdown mode, HSI clock after wakeup	4.5	20	80	

⁽¹⁾ Data based on characterization results, not tested in production.

10.3.2.5 Low power mode wakeup times

Table 29: Wakeup times

Symbol	Parameter	Conditions	Typ	Max ⁽¹⁾	Unit		
$t_{WU(WFI)}$	Wakeup time from wait mode to run mode ⁽³⁾	0 to 16 MHz		See note ⁽²⁾	μs		
		$f_{CPU} = f_{MASTER} = 16\text{ MHz}$	0.56				
$t_{WU(AH)}$	Wakeup time active halt mode to run mode ⁽³⁾	MVR voltage regulator on ⁽⁴⁾	Flash in operating mode ⁽⁵⁾	HSI (after wakeup)		1 ⁽⁶⁾	2 ⁽⁶⁾
	Wakeup time active halt mode to run mode ⁽³⁾	MVR voltage regulator on ⁽⁴⁾	Flash in power-down mode ⁽⁵⁾	HSI (after wakeup)		3 ⁽⁶⁾	
	Wakeup time active halt mode to run mode ⁽³⁾	MVR voltage regulator off ⁽⁴⁾	Flash in operating mode ⁽⁵⁾	HSI (after wakeup)		48 ⁽⁶⁾	
	Wakeup time active halt mode to run mode ⁽³⁾	MVR voltage regulator off ⁽⁴⁾	Flash in power-down mode ⁽⁵⁾	HSI (after wakeup)		50 ⁽⁶⁾	
$t_{WU(H)}$	Wakeup time from halt mode to run	Flash in operating mode ⁽⁵⁾		52			
		Flash in power-down mode ⁽⁵⁾		54			

Symbol	Parameter	Conditions	Typ	Max ⁽¹⁾	Unit
	mode ⁽³⁾				

- (1) Data guaranteed by design, not tested in production.
- (2) $t_{WU(WFI)} = 2 \times 1/f_{master} + 7 \times 1/f_{CPU}$.
- (3) Measured from interrupt event to interrupt vector fetch.
- (4) Configured by the REGAH bit in the CLK_I CKR register.
- (5) Configured by the AHALT bit in the FLASH_CR1 register.
- (6) Plus 1 LSI clock depending on synchronization.

10.3.2.6 Total current consumption and timing in forced reset state

Table 30: Total current consumption and timing in forced reset state

Symbol	Parameter	Conditions	Typ	Max ⁽¹⁾	Unit
I _{DD(R)}	Supply current in reset state ⁽²⁾	V _{DD} = 5 V	500		μA
		V _{DD} = 3.3 V	400		
t _{RESETBL}	Reset pin release to vector fetch			150	μs

- (1) Data guaranteed by design, not tested in production.
- (2) Characterized with all I/Os tied to V_{SS}.

10.3.2.7 Current consumption of on-chip peripherals

Subject to general operating conditions for V_{DD} and T_A.

HSI internal RC/f_{CPU} = f_{MASTER} = 16 MHz.

Table 31: Peripheral current consumption

Symbol	Parameter	Typ.	Unit
I _{DD(TIM1)}	TIM1 supply current ⁽¹⁾	230	μA
I _{DD(TIM2)}	TIM2 supply current ⁽¹⁾	115	

Symbol	Parameter	Typ.	Unit
$I_{DD(TIM3)}$	TIM3 timer supply current ⁽¹⁾	90	
$I_{DD(TIM4)}$	TIM4 timer supply current ⁽¹⁾	30	
$I_{DD(UART2)}$	UART2 supply current ⁽²⁾	110	
$I_{DD(SPI)}$	SPI supply current ⁽²⁾	45	
$I_{DD(I^2C)}$	I ² C supply current ⁽²⁾	65	
$I_{DD(ADC1)}$	ADC1 supply current when converting ⁽³⁾	955	

⁽¹⁾ Data based on a differential I_{DD} measurement between reset configuration and timer counter running at 16 MHz. No IC/OC programmed (no I/O pads toggling). Not tested in production.

⁽²⁾ Data based on a differential I_{DD} measurement between the on-chip peripheral when kept under reset and not clocked and the on-chip peripheral when clocked and not kept under reset. No I/O pads toggling. Not tested in production.

⁽³⁾ Data based on a differential I_{DD} measurement between reset configuration and continuous A/D conversions. Not tested in production.

10.3.2.8 Current consumption curves

The following figures show typical current consumption measured with code executing in RAM.

Figure 13: Typ. $I_{DD(RUN)}$ vs. V_{DD} , HSE user external clock, $f_{CPU} = 16$ MHz

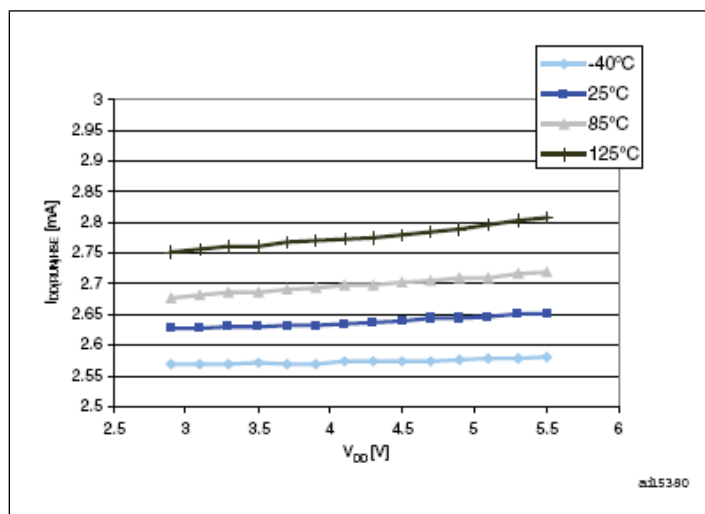

Figure 14: Typ. $I_{DD(RUN)}$ vs. f_{CPU} , HSE user external clock, $V_{DD} = 5\text{ V}$

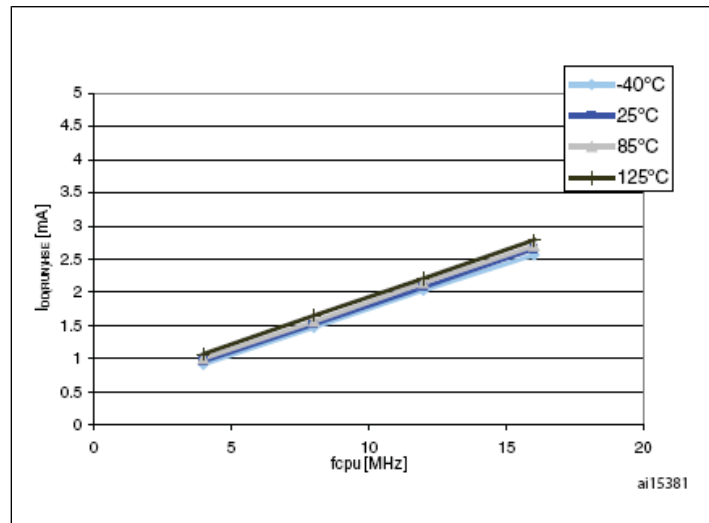

Figure 15: Typ. $I_{DD(RUN)}$ vs. V_{DD} , HSI RC osc, $f_{CPU} = 16\text{ MHz}$

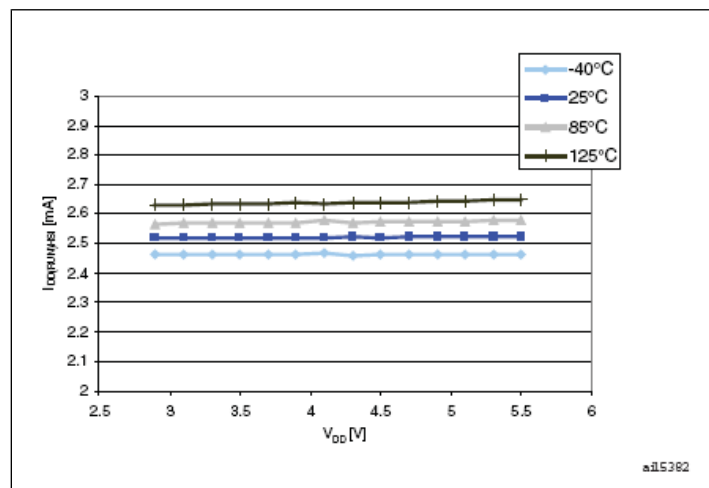

Figure 16: Typ. $I_{DD(WFI)}$ vs. V_{DD} , HSE user external clock, $f_{CPU} = 16$ MHz

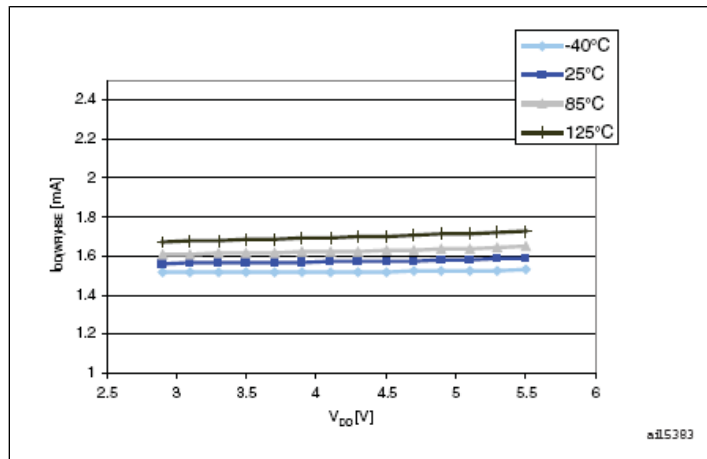

Figure 17: Typ. $I_{DD(WFI)}$ vs. f_{CPU} , HSE user external clock $V_{DD} = 5$ V

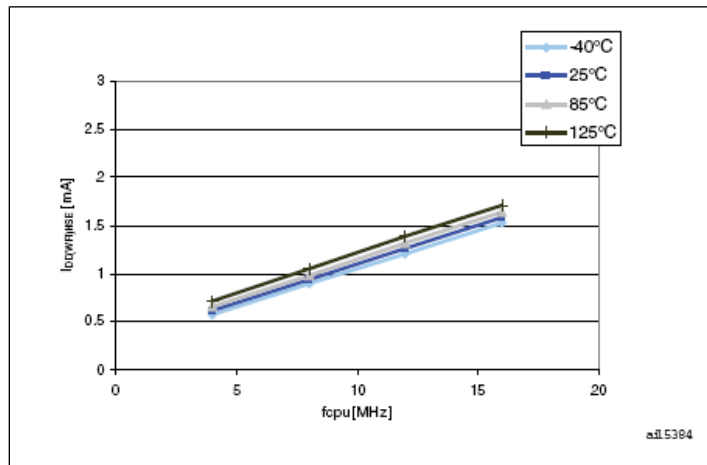
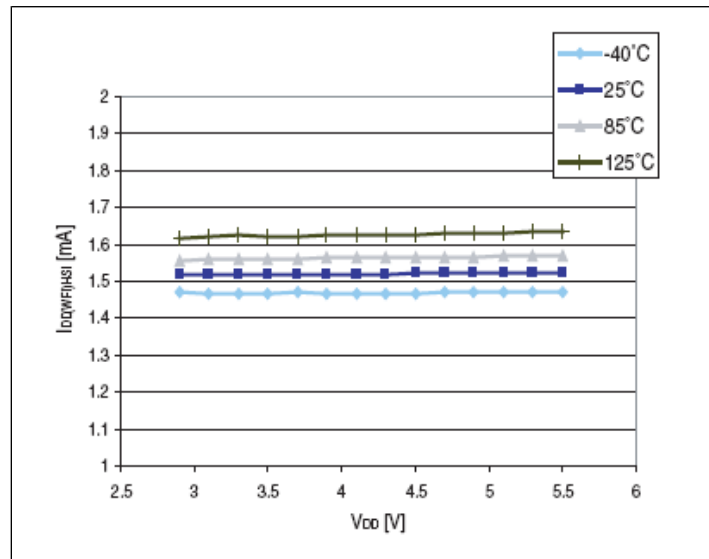

Figure 18: Typ. $I_{DD(WFI)}$ vs. V_{DD} , HSI RC osc, $f_{CPU} = 16$ MHz



10.3.3 External clock sources and timing characteristics

HSE user external clock

Subject to general operating conditions for V_{DD} and T_A .

Table 32: HSE user external clock characteristics

Symbol	Parameter	Conditions	Min	Max	Unit
f_{HSE_ext}	User external clock source frequency		0	16	MHz
$V_{HSEH}^{(1)}$	OSCIN input pin high level voltage		$0.7 \times V_{DD}$	$V_{DD} + 0.3$ V	V
$V_{HSEL}^{(1)}$	OSCIN input pin low level voltage		V_{SS}	$0.3 \times V_{DD}$	
I_{LEAK_HSE}	OSCIN input leakage current	$V_{SS} < V_{IN} < V_{DD}$	-1	+1	μ A

(1) Data based on characterization results, not tested in production.

Figure 19: HSE external clocksource

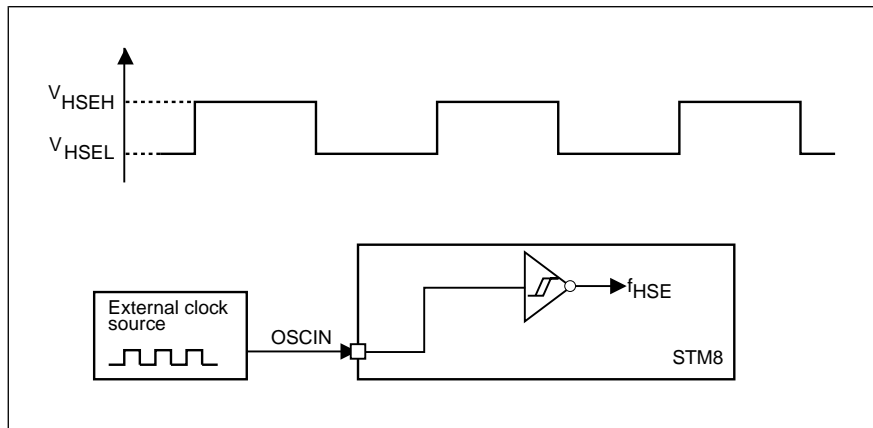

HSE crystal/ceramic resonator oscillator

The HSE clock can be supplied with a 1 to 16 MHz crystal/ceramic resonator oscillator. All the information given in this paragraph is based on characterization results with specified typical external components. In the application, the resonator and the load capacitors have to be placed as close as possible to the oscillator pins in order to minimize output distortion and start-up stabilization time. Refer to the crystal resonator manufacturer for more details (frequency, package, accuracy...).

Table 33: HSE oscillator characteristics

Symbol	Parameter	Conditions	Min	Typ	Max	Unit
f_{HSE}	External high speed oscillator frequency		1		16	MHz
R_F	Feedback resistor			220		kΩ
$C^{(1)}$	Recommended load capacitance ⁽²⁾				20	pF
$I_{DD(HSE)}$	HSE oscillator power consumption	$C = 20 \text{ pF},$ $f_{OSC} = 16 \text{ MHz}$			6 (startup) 1.6 (stabilized) ⁽³⁾	mA
		$C = 10 \text{ pF},$ $f_{OSC} = 16 \text{ MHz}$			6 (startup) 1.2 (stabilized) ⁽³⁾	
g_m	Oscillator transconductance		5			mA/V
$t_{SU(HSE)}^{(4)}$	Startup time	V_{DD} is stabilized		1		ms

⁽¹⁾ C is approximately equivalent to 2 x crystal Cload.

- (2) The oscillator selection can be optimized in terms of supply current using a high quality resonator with small R_m value. Refer to crystal manufacturer for more details
- (3) Data based on characterization results, not tested in production.
- (4) $t_{SU(HSE)}$ is the start-up time measured from the moment it is enabled (by software) to a stabilized 16 MHz oscillation is reached. This value is measured for a standard crystal resonator and it can vary significantly with the crystal manufacturer.

Figure 20: HSE oscillator circuit diagram

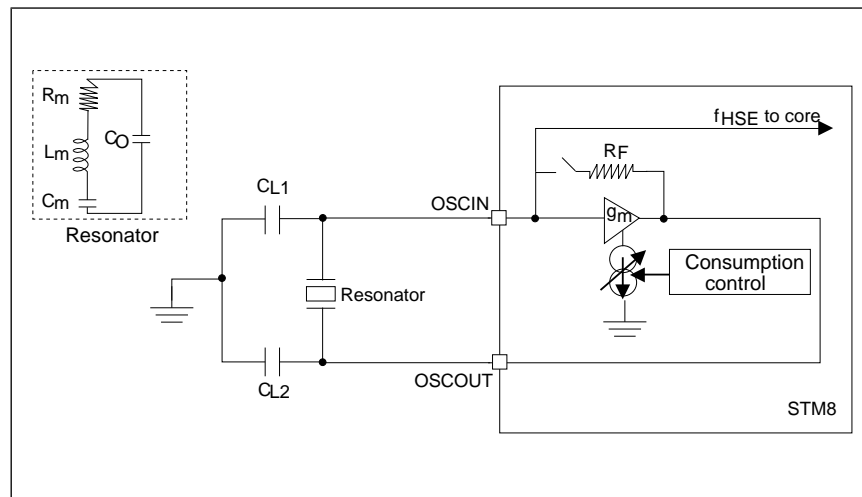

HSE oscillator critical g_m equation

$$g_{m\text{crit}} = (2 \times \pi \times f_{\text{HSE}})^2 \times R_m(2C_o + C)^2$$

R_m : Notional resistance (see crystal specification)

L_m : Notional inductance (see crystal specification)

C_m : Notional capacitance (see crystal specification)

C_o : Shunt capacitance (see crystal specification)

$C_{L1} = C_{L2} = C$: Grounded external capacitance

$g_m \gg g_{m\text{crit}}$

10.3.4 Internal clock sources and timing characteristics

Subject to general operating conditions for V_{DD} and T_A .

High speed internal RC oscillator (HSI)

Table 34: HSI oscillator characteristics

Symbol	Parameter	Conditions	Min	Typ	Max	Unit
f_{HSI}	Frequency			16		MHz

Symbol	Parameter	Conditions	Min	Typ	Max	Unit
ACC _{HSI}	Accuracy of HSI oscillator	User-trimmed with CLK_HSITRIMR register for given V _{DD} and T _A conditions ⁽¹⁾			1.0 ⁽²⁾	%
	Accuracy of HSI oscillator (factory calibrated)	V _{DD} = 5 V, T _A = 25°C ⁽³⁾	-1.0		1.0	
		V _{DD} = 5 V, 25 °C ≤ T _A ≤ 85 °C	-2.0		2.0	
		2.95 ≤ V _{DD} ≤ 5.5 V, -40 °C ≤ T _A ≤ 125 °C	-3.0 ⁽³⁾		3.0 ⁽³⁾	
t _{su(HSI)}	HSI oscillator wakeup time including calibration				1.0 ⁽²⁾	μs
I _{DD(HSI)}	HSI oscillator power consumption			170	250 ⁽³⁾	μA

- (1) Refer to application note.
- (2) Guaranteed by design, not tested in production.
- (3) Data based on characterization results, not tested in production.

Figure 21: Typical HSI accuracy at V_{DD} = 5 V vs 5 temperatures

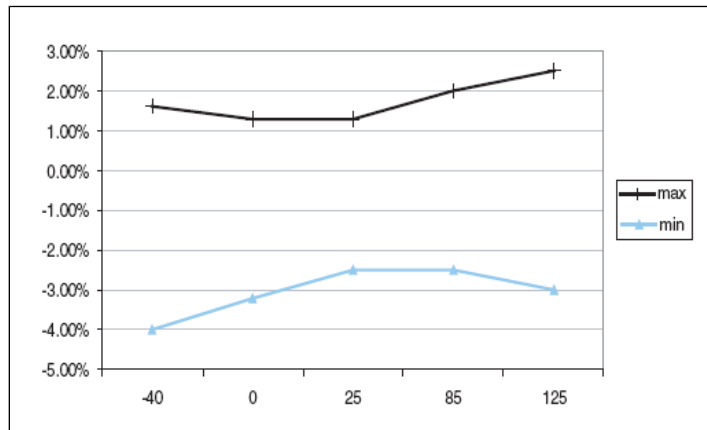
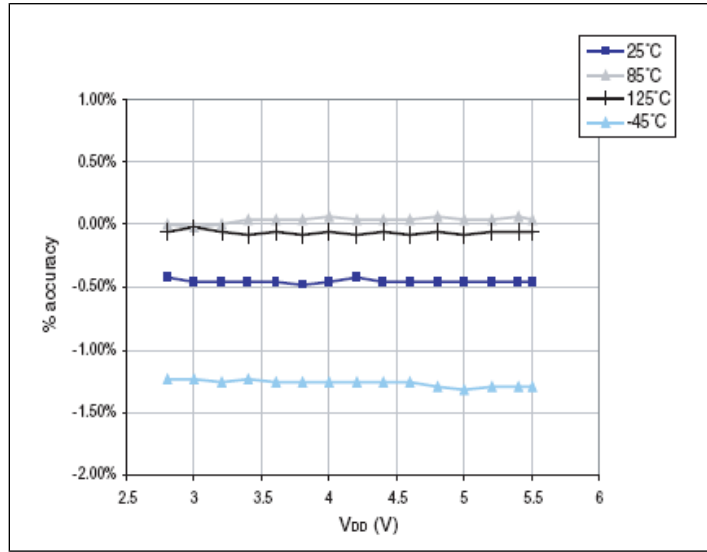

Figure 22: Typical HSI accuracy vs V_{DD} @ 4 temperatures



Low speed internal RC oscillator (LSI)

Subject to general operating conditions for V_{DD} and T_A.

Table 35: LSI oscillator characteristics

Symbol	Parameter	Min	Typ	Max	Unit
f _{LSI}	Frequency	110	128	146	kHz
t _{su(LSI)}	LSI oscillator wakeup time			7 ⁽¹⁾	µs
I _{DD(LSI)}	LSI oscillator power consumption		5		µA

⁽¹⁾ Guaranteed by design, not tested in production.

Figure 23: Typical LSI accuracy vs V_{DD} @ 4 temperatures

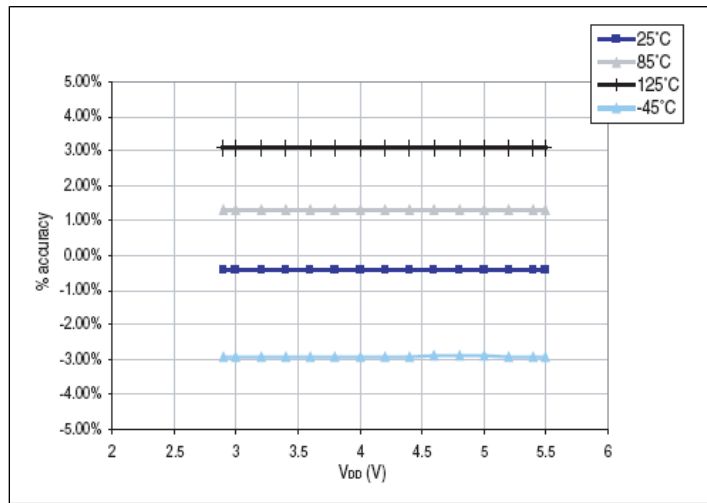

10.3.5 Memory characteristics

RAM and hardware registers

Table 36: RAM and hardware registers

Symbol	Parameter	Conditions	Min	Unit
V _{RM}	Data retention mode ⁽¹⁾	Halt mode (or reset)	V _{IT-max} ⁽²⁾	V

(1) Minimum supply voltage without losing data stored in RAM (in halt mode or under reset) or in hardware registers (only in halt mode). Guaranteed by design, not tested in production. refer to [Operating conditions](#) for the value of V_{IT-max}

(2) Refer to the Operating conditions section for the value of V_{IT-max}

Flash program memory/data EEPROM memory

General conditions: T_A = -40 to 125°C.

Table 37: Flash program memory/data EEPROM memory

Symbol	Parameter	Conditions	Min ⁽¹⁾	Typ	Max	Unit
V _{DD}	Operating voltage (all modes, execution/write/erase)	f _{CPU} ≤ 16 MHz	2.95		5.5	V
t _{prog}	Standard programming time (including erase) for byte/word/block (1 byte/4 bytes/128 bytes)			6.0	6.6	ms

Symbol	Parameter	Conditions	Min ⁽¹⁾	Typ	Max	Unit
	Fast programming time for 1 block (128 bytes)			3.0	3.3	ms
t_{erase}	Erase time for 1 block (128 bytes)			3.0	3.3	ms
N_{RW}	Erase/write cycles ⁽²⁾ (program memory)	$T_A = +85^\circ\text{C}$	10 k			cycles
	Erase/write cycles(data memory) ⁽²⁾	$T_A = +125^\circ\text{C}$	300 k	1.0M		
t_{RET}	Data retention (program memory) after 10k erase/write cycles at $T_A = +85^\circ\text{C}$	$T_{\text{RET}} = 55^\circ\text{C}$	20			years
	Data retention (data memory) after 10k erase/write cycles at $T_A = +85^\circ\text{C}$	$T_{\text{RET}} = 55^\circ\text{C}$	20			
	Data retention (data memory) after 300 k erase/write cycles at $T_A = +125^\circ\text{C}$	$T_{\text{RET}} = 85^\circ\text{C}$	1.0			
I_{DD}	Supply current (Flash programming or erasing for 1 to 128 bytes)			2.0		mA

(1) Data based on characterization results, not tested in production.

(2) The physical granularity of the memory is 4 bytes, so cycling is performed on 4 bytes even when a write/erase operation addresses a single byte.

10.3.6 I/O port pin characteristics

General characteristics

Subject to general operating conditions for V_{DD} and T_A unless otherwise specified. All unused pins must be kept at a fixed voltage: using the output mode of the I/O for example or an external pull-up or pull-down resistor.

Table 38: I/O static characteristics

Symbol	Parameter	Conditions	Min	Typ	Max	Unit
V_{IL}	Input low level voltage	$V_{\text{DD}} = 5\text{V}$	-0.3		$0.3 \times V_{\text{DD}}$	V

Symbol	Parameter	Conditions	Min	Typ	Max	Unit
V_{IH}	Input high level voltage		$0.7 \times V_{DD}$		$V_{DD} + 0.3$ V	V
V_{hys}	Hysteresis ⁽¹⁾			700		mV
R_{pu}	Pull-up resistor	$V_{DD} = 5$ V, $V_{IN} = V_{SS}$	30	55	80	k Ω
t_R, t_F	Rise and fall time(10 % - 90 %)	Fast I/Os load = 50 pF			35 ⁽³⁾	ns
		Standard and high sink I/OsLoad = 50 pF			125 ⁽³⁾	
		Fast I/Os load = 20 pF			20 ⁽³⁾	
		Standard and high sink I/OsLoad = 20 pF			50 ⁽³⁾	
I_{lkg}	Input leakage current, analog and digital	$V_{SS} \leq V_{IN} \leq V_{DD}$			± 1.0 ⁽²⁾	μ A
$I_{lkg\ ana}$	Analog input leakage current	$V_{SS} \leq V_{IN} \leq V_{DD}$			± 250 ⁽²⁾	nA
$I_{lkg(inj)}$	Leakage current in adjacent I/O ⁽²⁾	Injection current ± 4 mA			± 1.0 ⁽²⁾	μ A

⁽¹⁾ Hysteresis voltage between Schmitt trigger switching levels. Based on characterization results, not tested in production.

⁽²⁾ Data based on characterization results, not tested in production.

⁽³⁾Data guaranteed by design.

Figure 24: Typical V_{IL} and V_{IH} vs V_{DD} @ 4 temperatures

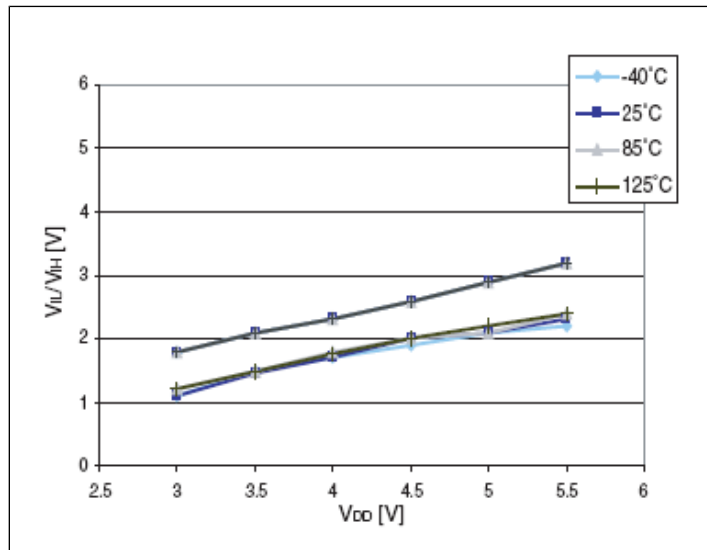

Figure 25: Typical pull-up resistance vs V_{DD} @ 4 temperatures

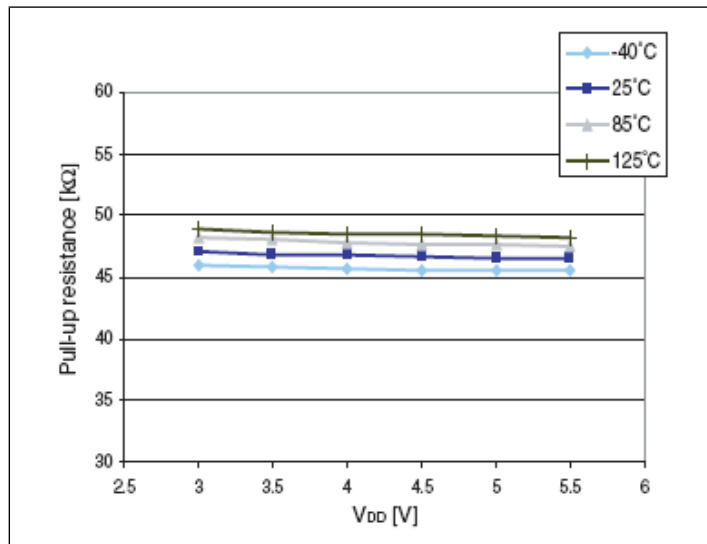
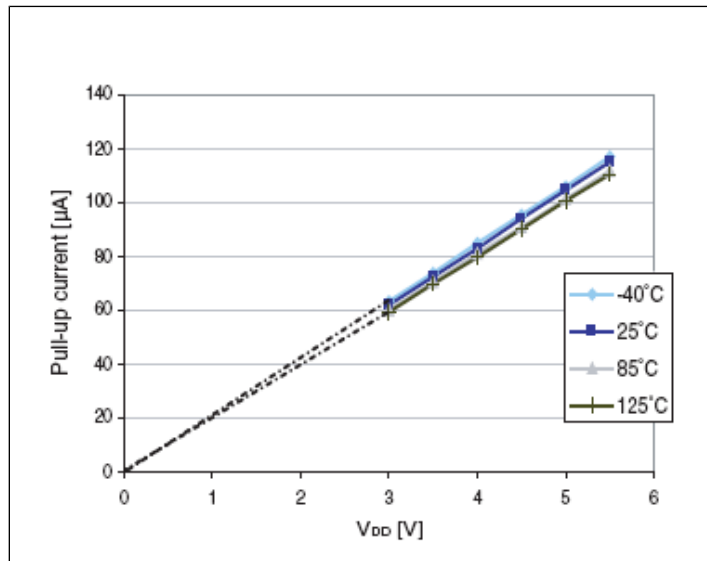

Figure 26: Typical pull-up current vs V_{DD} @ 4 temperatures



1. The pull-up is a pure resistor (slope goes through 0).

Table 39: Output driving current (standard ports)

Symbol	Parameter	Conditions	Min	Max	Unit
V_{OL}	Output low level with four pins sunk	$I_{IO} = 4 \text{ mA}$, $V_{DD} = 3.3 \text{ V}$		1.0 ⁽¹⁾	V
	Output low level with eight pins sunk	$I_{IO} = 10 \text{ mA}$, $V_{DD} = 5 \text{ V}$		2.0	
V_{OH}	Output high level with four pins sourced	$I_{IO} = 4 \text{ mA}$, $V_{DD} = 3.3 \text{ V}$	2.0 ⁽¹⁾		V
	Output high level with eight pins sourced	$I_{IO} = 10 \text{ mA}$, $V_{DD} = 5 \text{ V}$	2.4		

⁽¹⁾ Data based on characterization results, not tested in production

Table 40: Output driving current (true open drain ports)

Symbol	Parameter	Conditions	Max	Unit
V_{OL}	Output low level with two pins sunk	$I_{IO} = 10 \text{ mA}$, $V_{DD} = 3.3 \text{ V}$	1.5 ⁽¹⁾	V

Symbol	Parameter	Conditions	Max	Unit
		$I_{IO} = 10 \text{ mA}, V_{DD} = 5 \text{ V}$	1.0	
		$I_{IO} = 20 \text{ mA}, V_{DD} = 5 \text{ V}$	2.0 ⁽¹⁾	

⁽¹⁾ Data based on characterization results, not tested in production

Table 41: Output driving current (high sink ports)

Symbol	Parameter	Conditions	Min	Max	Unit
V_{OL}	Output low level with four pins sunk	$I_{IO} = 10 \text{ mA}, V_{DD} = 3.3 \text{ V}$		1.1 ⁽¹⁾	V
	Output low level with eight pins sunk	$I_{IO} = 10 \text{ mA}, V_{DD} = 5 \text{ V}$		0.9	
	Output low level with four pins sunk	$I_{IO} = 20 \text{ mA}, V_{DD} = 5 \text{ V}$		1.6 ⁽¹⁾	
V_{OH}	Output high level with four pins sourced	$I_{IO} = 10 \text{ mA}, V_{DD} = 3.3 \text{ V}$	1.9 ⁽¹⁾		
	Output high level with eight pins sourced	$I_{IO} = 10 \text{ mA}, V_{DD} = 5 \text{ V}$	3.8		
	Output high level with four pins sourced	$I_{IO} = 20 \text{ mA}, V_{DD} = 5 \text{ V}$	2.9 ⁽¹⁾		

⁽¹⁾ Data based on characterization results, not tested in production

10.3.7 Typical output level curves

The following figures show typical output level curves measured with output on a single pin.

Figure 27: Typ. V_{OL} @ $V_{DD} = 5\text{ V}$ (standard ports)

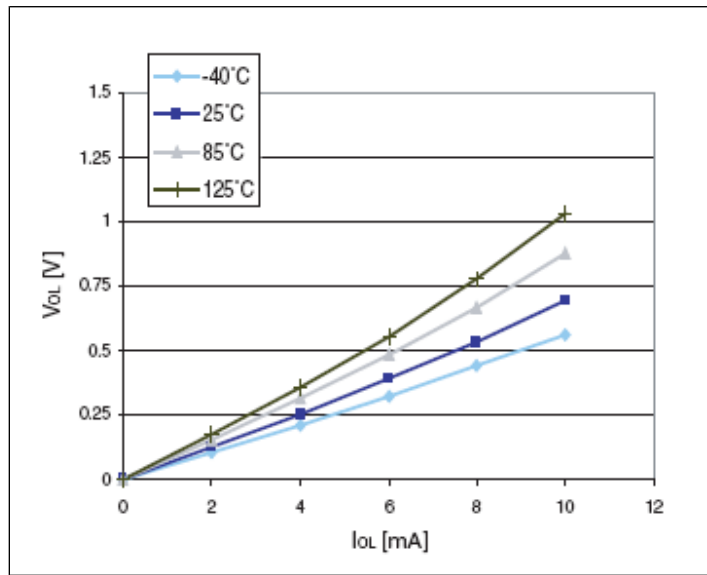

Figure 28: Typ. V_{OL} @ $V_{DD} = 3.3\text{ V}$ (standard ports)

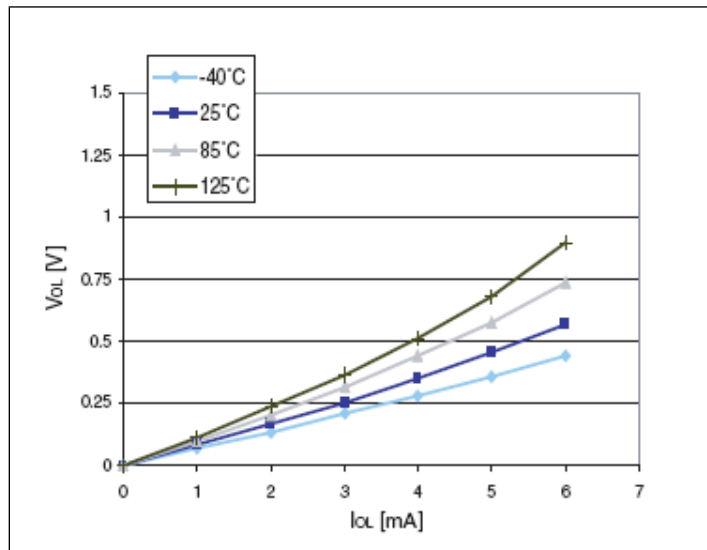

Figure 29: Typ. V_{OL} @ $V_{DD} = 5\text{ V}$ (true open drain ports)

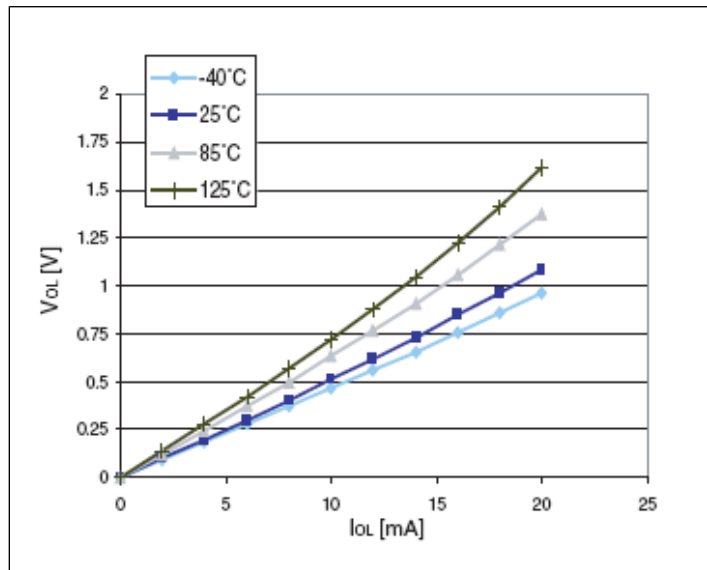

Figure 30: Typ. V_{OL} @ $V_{DD} = 3.3\text{ V}$ (true open drain ports)

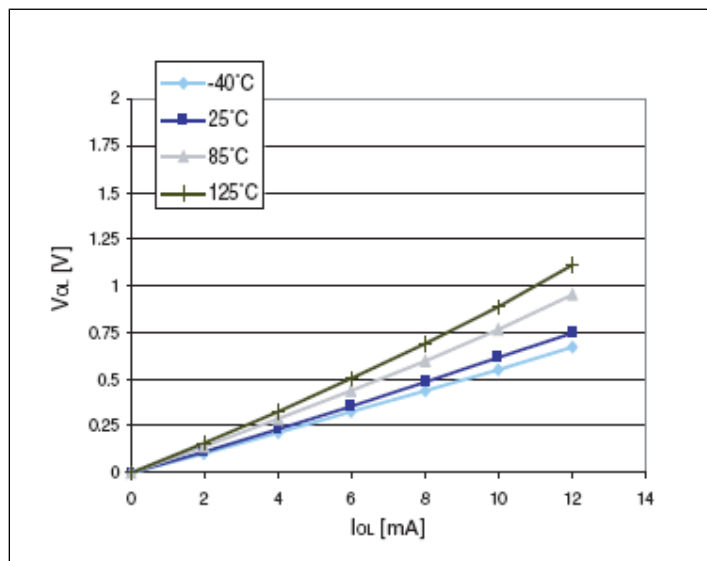

Figure 31: Typ. V_{OL} @ $V_{DD} = 5\text{ V}$ (high sink ports)

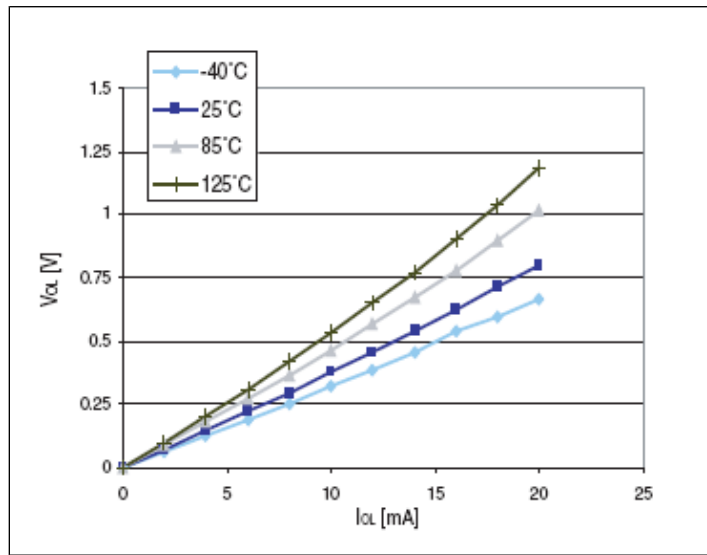

Figure 32: Typ. V_{OL} @ $V_{DD} = 3.3\text{ V}$ (high sink ports)

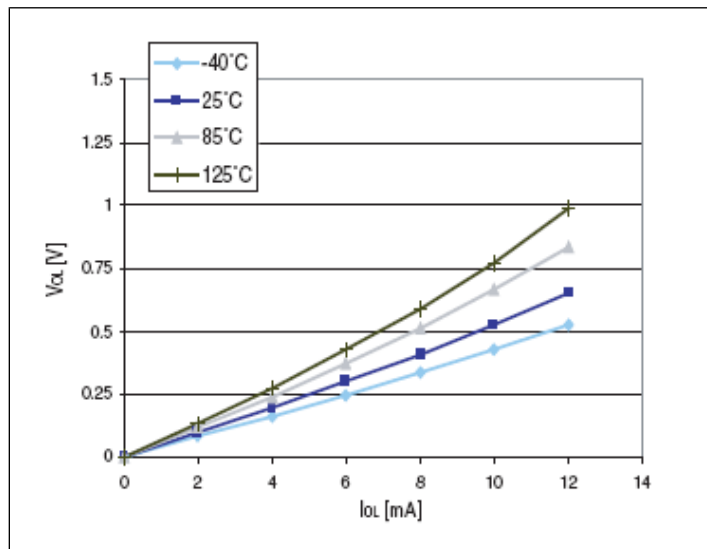

Figure 33: Typ. $V_{DD} - V_{OH}$ @ $V_{DD} = 5\text{ V}$ (standard ports)

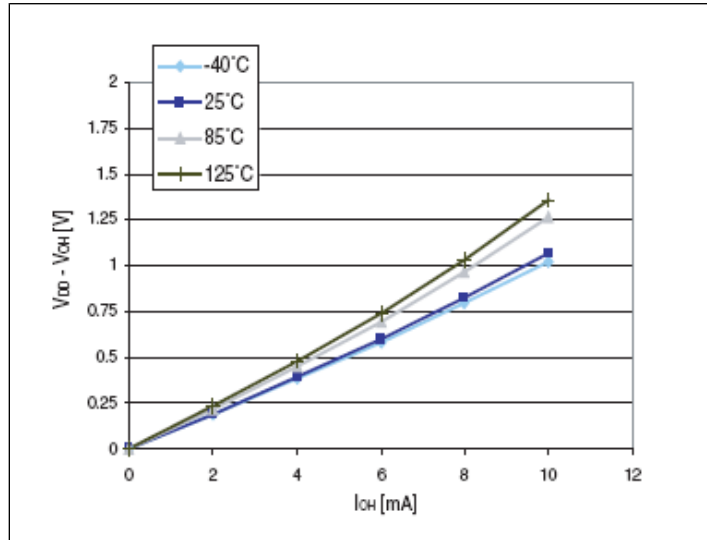

Figure 34: Typ. $V_{DD} - V_{OH}$ @ $V_{DD} = 3.3\text{ V}$ (standard ports)

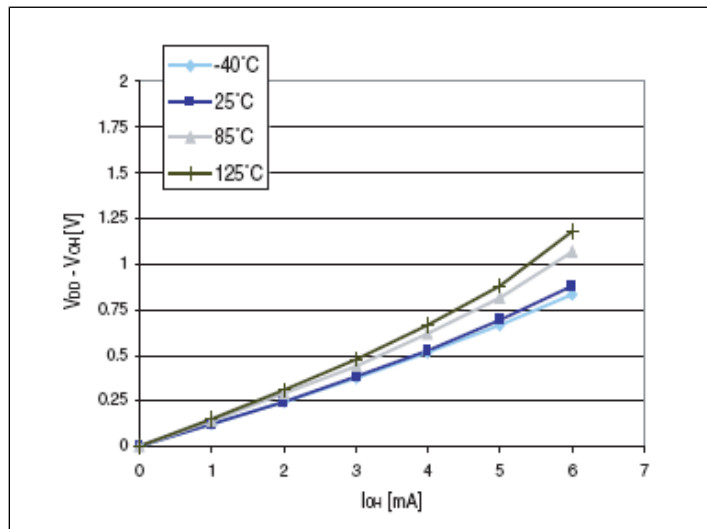

Figure 35: Typ. $V_{DD} - V_{OH}$ @ $V_{DD} = 5\text{ V}$ (high sink ports)

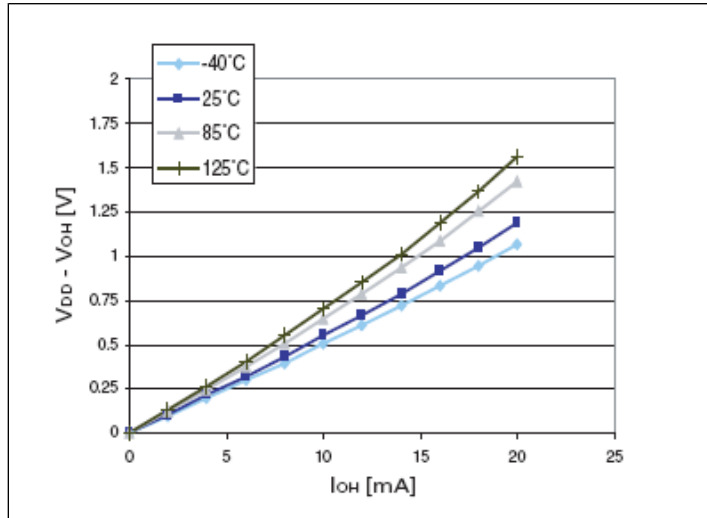
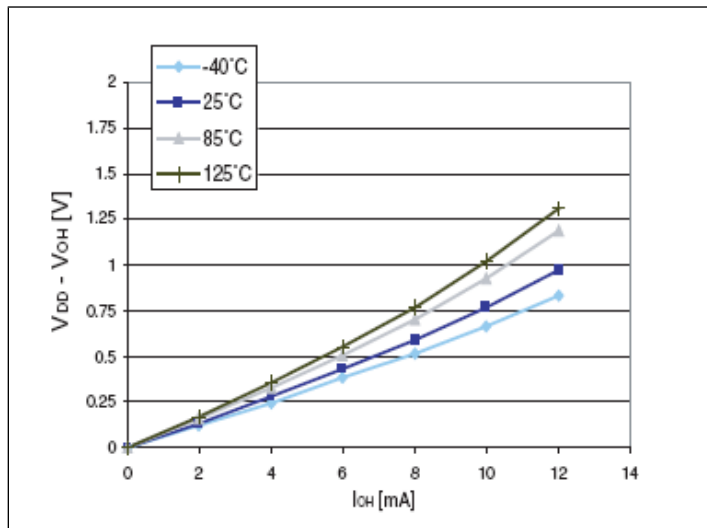

Figure 36: Typ. $V_{DD} - V_{OH}$ @ $V_{DD} = 3.3\text{ V}$ (high sink ports)



10.3.8 Reset pin characteristics

Subject to general operating conditions for V_{DD} and T_A unless otherwise specified.

Table 42: NRST pin characteristics

Symbol	Parameter	Conditions	Min	Typ	Max	Unit
$V_{IL(NRST)}$	NRST input low level voltage ⁽¹⁾		-0.3	-	$0.3 \times V_{DD}$	V
$V_{IH(NRST)}$	NRST input high	$I_{OL} = 2\text{ mA}$	$0.7 \times V_{DD}$	-	$V_{DD} + 0.3$	

Symbol	Parameter	Conditions	Min	Typ	Max	Unit
	level voltage ⁽¹⁾					
V _{OL(NRST)}	NRST output low level voltage ⁽¹⁾		-	-	0.5	
R _{PU(NRST)}	NRST pull-up resistor ⁽²⁾		30	55	80	kΩ
t _{i FP(NRST)}	NRST input filtered pulse ⁽³⁾		-	-	75	ns
t _{iN FP(NRST)}	NRST input not filtered pulse ⁽³⁾		500	-	-	
t _{OP(NRST)}	NRST output pulse ⁽³⁾		15	-	-	μs

(1) Data based on characterization results, not tested in production.

(2) The R_{PU} pull-up equivalent resistor is based on a resistive transistor

(3) Data guaranteed by design, not tested in production.

Figure 37: Typical NRST V_{IL} and V_{IH} vs V_{DD} @ 4 temperatures

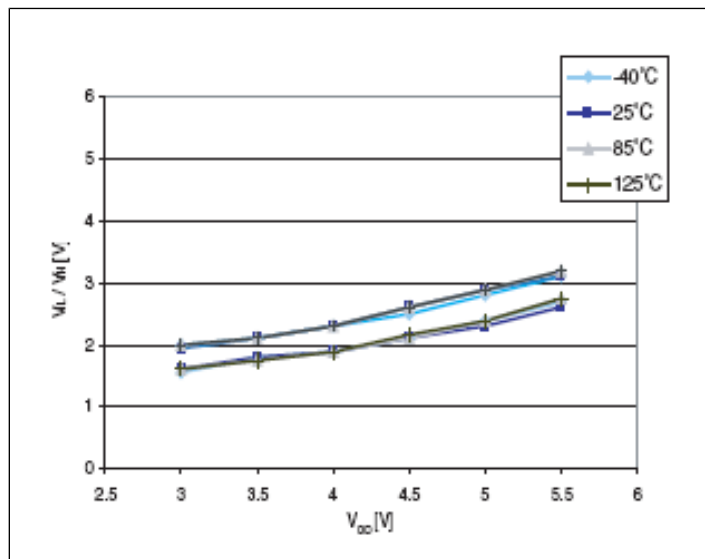

Figure 38: Typical NRST pull-up resistance vs V_{DD} @ 4 temperatures

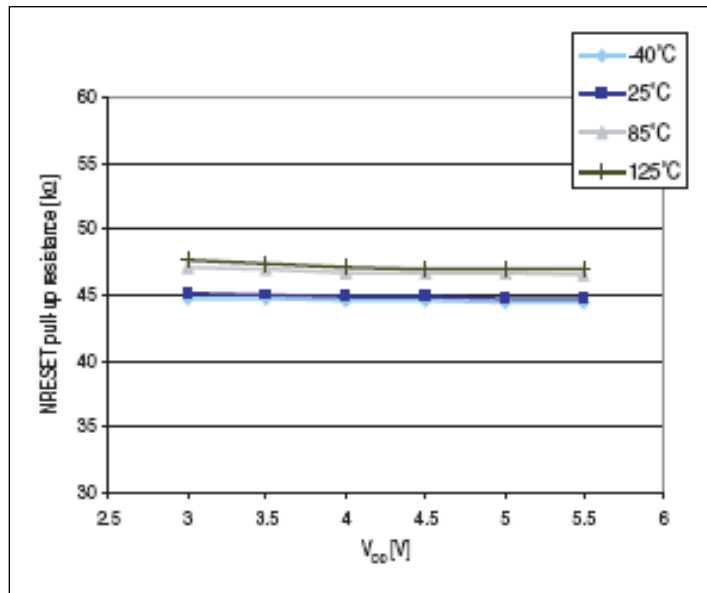
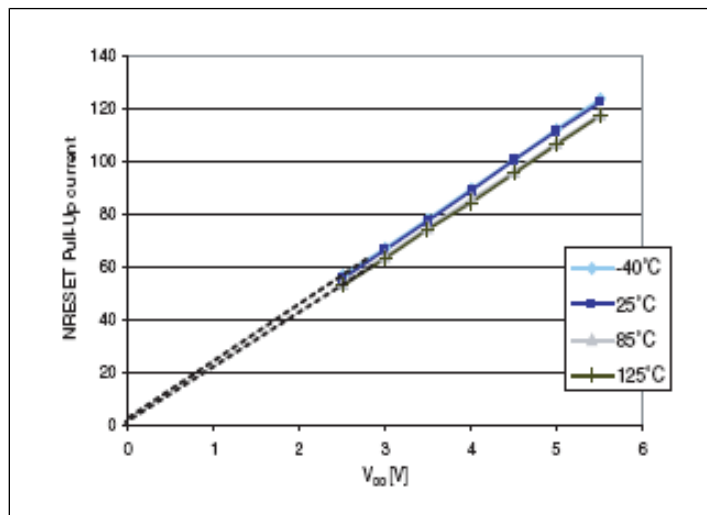

Figure 39: Typical NRST pull-up current vs V_{DD} @ 4 temperatures



The reset network shown in the following figure protects the device against parasitic resets. The user must ensure that the level on the NRST pin can go below $V_{IL(NRST)}$ max. (see [Table 38: I/O static characteristics](#)), otherwise the reset is not taken into account internally.

For power consumption sensitive applications, the external reset capacitor value can be reduced to limit the charge/discharge current. If NRST signal is used to reset external circuitry, attention must be taken to the charge/discharge time of the external capacitor to fulfill the external devices reset timing conditions. Minimum recommended capacity is 100 nF.

Figure 40: Recommended reset pin protection

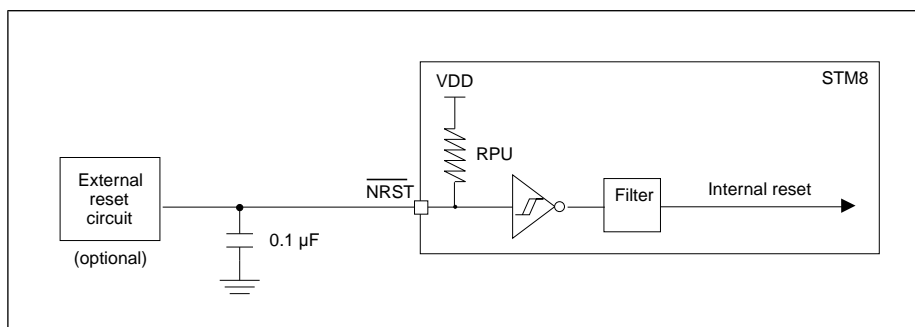

10.3.9 SPI serial peripheral interface

Unless otherwise specified, the parameters given in the following table are derived from tests performed under ambient temperature, f_{MASTER} frequency and V_{DD} supply voltage conditions.
 $t_{MASTER} = 1/f_{MASTER}$

Refer to I/O port characteristics for more details on the input/output alternate function characteristics (NSS, SCK, MOSI, MISO).

Table 43: SPI characteristics

Symbol	Parameter	Conditions	Min	Max	Unit
f_{SCK1}	SPI clock frequency	Master mode	0	8	MHz
$t_{c(SCK)}$		Slave mode	0	6	
$t_{r(SCK)}$ $t_{f(SCK)}$	SPI clock rise and fall time	Capacitive load: C = 30 pF		25	ns
$t_{su(NSS)}^{(1)}$	NSS setup time	Slave mode	4 x t_{MASTER}		ns
$t_{h(NSS)}^{(1)}$	NSS hold time	Slave mode	70		ns
$t_{w(SCKH)}^{(1)}$ $t_{w(SCKL)}^{(1)}$	SCK high and low time	Master mode	$t_{SCK}/2 - 15$	$t_{SCK}/2 + 15$	ns
$t_{su(MI)}^{(1)}$ $t_{su(SI)}^{(1)}$	Data input setup time	Master mode	5		ns
	Data input setup time	Slave mode	5		ns

Symbol	Parameter	Conditions	Min	Max	Unit
$t_{h(MI)}^{(1)}$ $t_{h(SI)}^{(1)}$	Data input hold time	Master mode	7		ns
	Data input hold time	Slave mode	10		ns
$t_{a(SO)}^{(1)(2)}$	Data output access time	Slave mode		3 x t_{MASTER}	ns
$t_{dis(SO)}^{(1)(3)}$	Data output disable time	Slave mode	25		ns
$t_{v(SO)}^{(1)}$	Data output valid time	Slave mode (after enable edge)		73	ns
$t_{v(MO)}^{(1)}$	Data output valid time	Master mode (after enable edge)		36	ns
$t_{h(SO)}^{(1)}$	Data output hold time	Slave mode (after enable edge)	28		ns
$t_{h(MO)}^{(1)}$		Master mode (after enable edge)	12		ns

(1) Values based on design simulation and/or characterization results, and not tested in production.

(2) Min time is for the minimum time to drive the output and the max time is for the maximum time to validate the data.

(3) Min time is for the minimum time to invalidate the output and the max time is for the maximum time to put the data in Hi-Z.

Figure 41: SPI timing diagram - slave mode and CPHA = 0

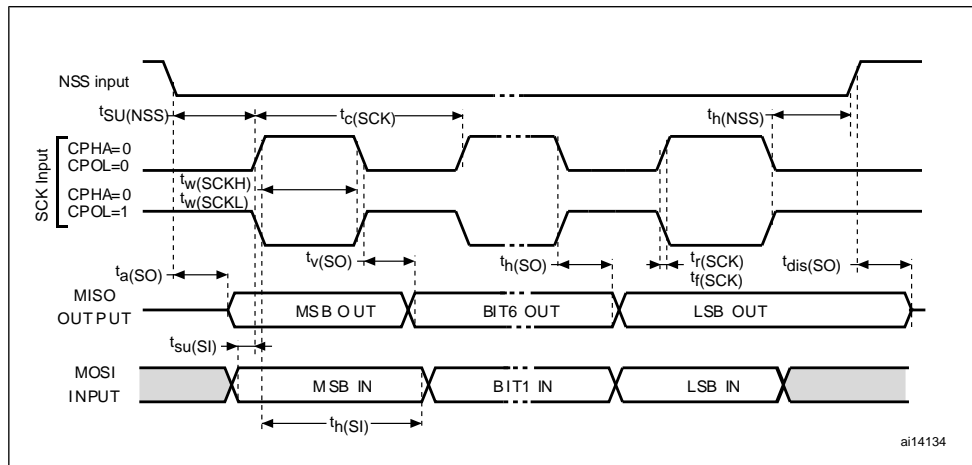
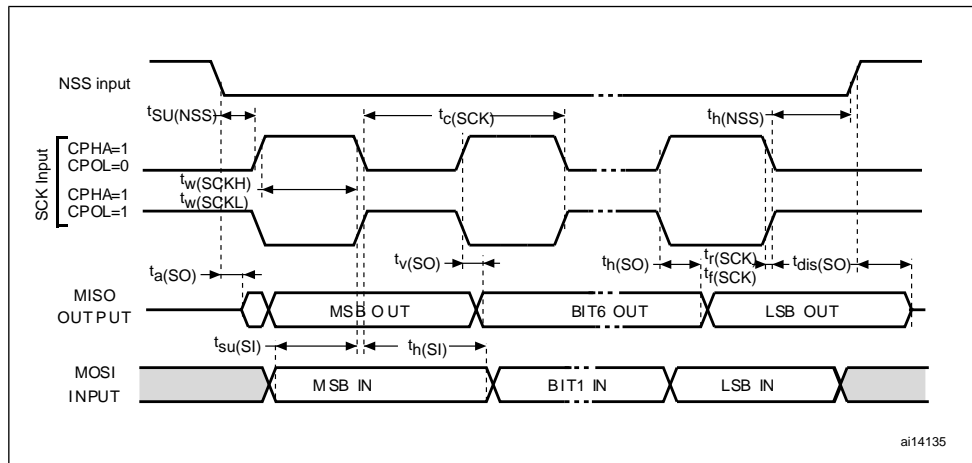
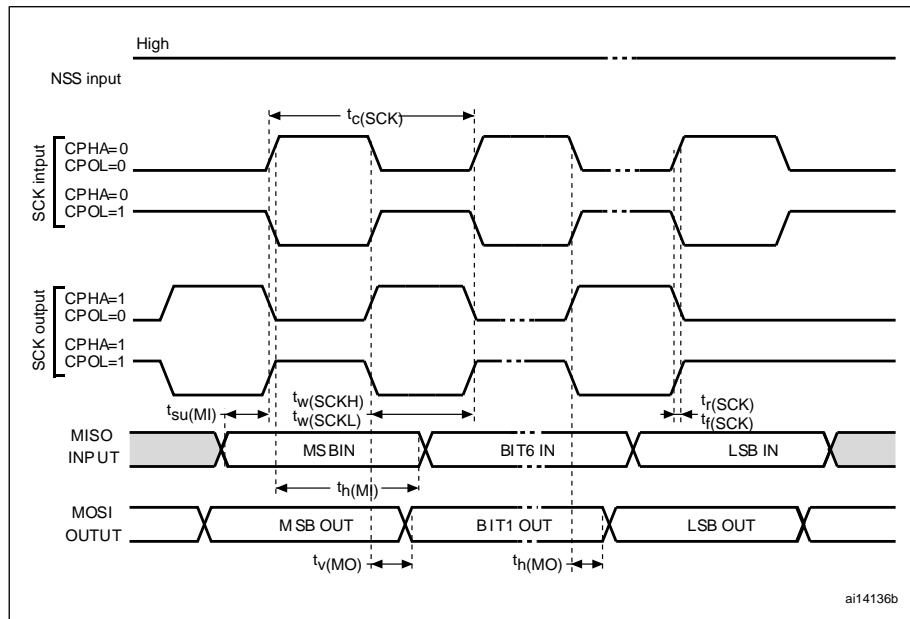

Figure 42: SPI timing diagram - slave mode and CPHA = 1⁽¹⁾



1. Measurement points are made at CMOS levels: 0.3 V_{DD} and 0.7 V_{DD} .

Figure 43: SPI timing diagram - master mode⁽¹⁾



1. Measurement points are made at CMOS levels: 0.3 V_{DD} and 0.7 V_{DD} .

10.3.10 I²C interface characteristics

Table 44: I²C characteristics

Symbol	Parameter	Standard mode I ² C		Fast mode I ² C ⁽¹⁾		Unit
		Min ⁽²⁾	Max ⁽²⁾	Min ⁽²⁾	Max ⁽²⁾	
$t_{w(SCLL)}$	SCL clock low time	4.7		1.3		μ s
$t_{w(SCLH)}$	SCL clock high time	4.0		0.6		μ s
$t_{su(SDA)}$	SDA setup time	250		100		ns
$t_{h(SDA)}$	SDA data hold time	0 ⁽³⁾		0 ⁽⁴⁾	900 ⁽³⁾	ns
$t_{r(SDA)}$ $t_{r(SCL)}$	SDA and SCL rise time		1000		300	ns
$t_{f(SDA)}$ $t_{f(SCL)}$	SDA and SCL fall time		300		300	ns

Symbol	Parameter	Standard mode I ² C		Fast mode I ² C ⁽¹⁾		Unit
		Min ⁽²⁾	Max ⁽²⁾	Min ⁽²⁾	Max ⁽²⁾	
t _{h(STA)}	START condition hold time	4.0		0.6		μs
t _{su(STA)}	Repeated START condition setup time	4.7		0.6		μs
t _{su(STO)}	STOP condition setup time	4.0		0.6		μs
t _{w(STO:STA)}	STOP to START condition time (bus free)	4.7		1.3		μs
C _b	Capacitive load for each bus line		400		400	pF

(1) f_{MASTER} must be at least 8 MHz to achieve max fast I²C speed (400kHz).

(2) Data based on standard I²C protocol requirement, not tested in production.

(3) The maximum hold time of the start condition has only to be met if the interface does not stretch the low time.

(4) The device must internally provide a hold time of at least 300 ns for the SDA signal in order to bridge the undefined region of the falling edge of SCL.

Figure 44: Typical application with I²C bus and timing diagram ⁽¹⁾

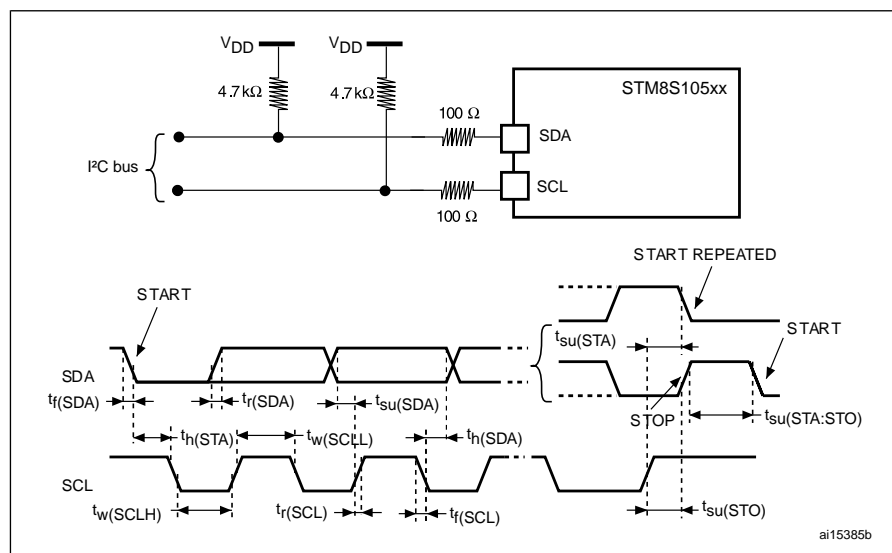

1. Measurement points are made at CMOS levels: 0.3 x V_{DD} and 0.7 x V_{DD}

10.3.11 10-bit ADC characteristics

Subject to general operating conditions for V_{DDA} , f_{MASTER} , and T_A unless otherwise specified.

Table 45: ADC characteristics

Symbol	Parameter	Conditions	Min	Typ	Max	Unit
f_{ADC}	ADC clock frequency	$V_{DDA} = 2.95$ to 5.5 V	1.0		4.0	MHz
		$V_{DDA} = 4.5$ to 5.5 V	1.0		6.0	
V_{DDA}	Analog supply		3.0		5.5	V
V_{REF+}	Positive reference voltage		2.75 ⁽¹⁾		V_{DDA}	V
V_{REF-}	Negative reference voltage		V_{SSA}		0.5 ⁽¹⁾	V
V_{AIN}	Conversion voltage range ⁽²⁾		V_{SSA}		V_{DDA}	V
		Devices with external V_{REF+}/V_{REF-} pins	V_{REF-}		V_{REF+}	V
C_{ADC}	Internal sample and hold capacitor			3.0		pF
t_S ⁽²⁾	Sampling time	$f_{ADC} = 4$ MHz	0.75			μ s
		$f_{ADC} = 6$ MHz	0.5			
t_{STAB}	Wakeup time from standby			7.0		μ s
t_{CONV}	Total conversion time (including sampling time, 10-bit resolution)	$f_{ADC} = 4$ MHz	3.5			μ s
		$f_{ADC} = 6$ MHz	2.33			μ s
			14			$1/f_{ADC}$

⁽¹⁾ Data guaranteed by design, not tested in production..

⁽²⁾ During the sample time the input capacitance C_{AIN} (3 pF max) can be charged/discharged by the external source. The internal resistance of the analog source must allow the capacitance to reach its final voltage level within t_S . After the end of the sample time t_S ,

changes of the analog input voltage have no effect on the conversion result. Values for the sample clock t_S depend on programming.

Table 46: ADC accuracy with $R_{AIN} < 10 \text{ k}\Omega$, $V_{DDA} = 5 \text{ V}$

Symbol	Parameter	Conditions	Typ	Max ⁽¹⁾	Unit
E _T	Total unadjusted error ⁽²⁾	f _{ADC} = 2 MHz	1.0	2.5	LSB
		f _{ADC} = 4 MHz	1.4	3.0	
		f _{ADC} = 6 MHz	1.6	3.5	
E _O	Offset error ⁽²⁾	f _{ADC} = 2 MHz	0.6	2.0	
		f _{ADC} = 4 MHz	1.1	2.5	
		f _{ADC} = 6 MHz	1.2	2.5	
E _G	Gain error ⁽²⁾	f _{ADC} = 2 MHz	0.2	2.0	
		f _{ADC} = 4 MHz	0.6	2.5	
		f _{ADC} = 6 MHz	0.8	2.5	
E _D	Differential linearity error ⁽²⁾	f _{ADC} = 2 MHz	0.7	1.5	
		f _{ADC} = 4 MHz	0.7	1.5	
		f _{ADC} = 6 MHz	0.8	1.5	
E _L	Integral linearity error ⁽²⁾	f _{ADC} = 2 MHz	0.6	1.5	
		f _{ADC} = 4 MHz	0.6	1.5	
		f _{ADC} = 6 MHz	0.6	1.5	

⁽¹⁾ Data based on characterisation results, not tested in production.

⁽²⁾ ADC accuracy vs. negative injection current: Injecting negative current on any of the analog input pins should be avoided as this significantly reduces the accuracy of the conversion being performed on another analog input. It is recommended to add a Schottky diode (pin to ground) to standard analog pins which may potentially inject negative current.

Any positive injection current within the limits specified for $I_{INJ(PIN)}$ and $\Sigma I_{INJ(PIN)}$ in the I/O port pin characteristics section does not affect the ADC accuracy.

Table 47: ADC accuracy with $R_{AIN} < 10 \text{ k}\Omega$, R_{AIN} , $V_{DDA} = 3.3 \text{ V}$

Symbol	Parameter	Conditions	Typ	Max ⁽¹⁾	Unit
E _T	Total unadjusted error ⁽²⁾	f _{ADC} = 2 MHz	1.1	2.0	LSB
		f _{ADC} = 4 MHz	1.6	2.5	
E _O	Offset error ⁽²⁾	f _{ADC} = 2 MHz	0.7	1.5	
		f _{ADC} = 4 MHz	1.3	2.0	
E _G	Gain error ⁽²⁾	f _{ADC} = 2 MHz	0.2	1.5	
		f _{ADC} = 4 MHz	0.5	2.0	
E _D	Differential linearity error ⁽²⁾	f _{ADC} = 2 MHz	0.7	1.0	
		f _{ADC} = 4 MHz	0.7	1.0	
E _L	Integral linearity error ⁽²⁾	f _{ADC} = 2 MHz	0.6	1.5	
		f _{ADC} = 4 MHz	0.6	1.5	

⁽¹⁾ Data based on characterisation results, not tested in production.

⁽²⁾ ADC accuracy vs. negative injection current: Injecting negative current on any of the analog input pins should be avoided as this significantly reduces the accuracy of the conversion being performed on another analog input. It is recommended to add a Schottky diode (pin to ground) to standard analog pins which may potentially inject negative current. Any positive injection current within the limits specified for $I_{INJ(PIN)}$ and $\Sigma I_{INJ(PIN)}$ in *I/O port pin characteristics* does not affect the ADC accuracy.

Figure 45: ADC accuracy characteristics

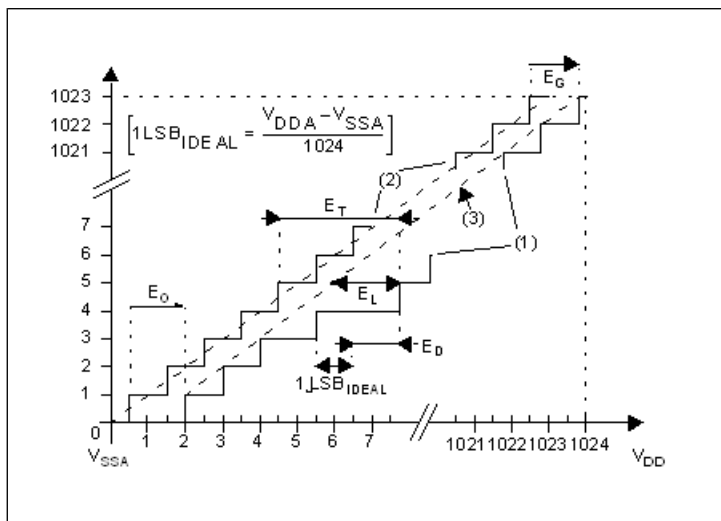

1. Example of an actual transfer curve.
2. The ideal transfer curve
3. End point correlation line

E_T = Total unadjusted error: maximum deviation between the actual and the ideal transfer curves.

E_O = Offset error: deviation between the first actual transition and the first ideal one.

E_G = Gain error: deviation between the last ideal transition and the last actual one.

E_D = Differential linearity error: maximum deviation between actual steps and the ideal one.

E_L = Integral linearity error: maximum deviation between any actual transition and the end point correlation line.

Figure 46: Typical application with ADC

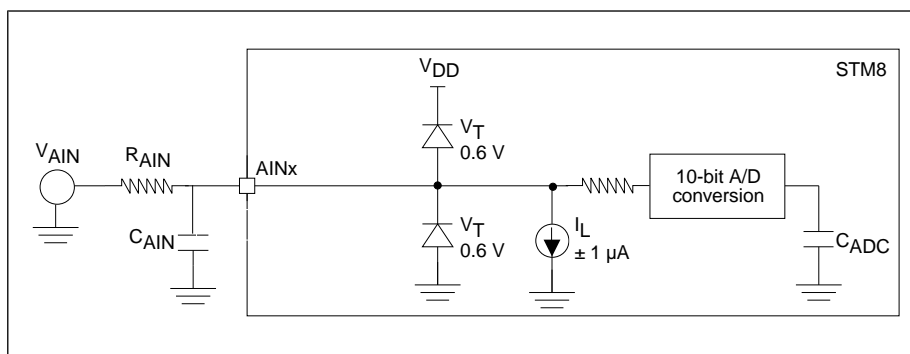

10.3.12 EMC characteristics

Susceptibility tests are performed on a sample basis during product characterization.

10.3.12.1 Functional EMS (electromagnetic susceptibility)

While executing a simple application (toggling 2 LEDs through I/O ports), the product is stressed by two electromagnetic events until a failure occurs (indicated by the LEDs).

- FESD: Functional electrostatic discharge (positive and negative) is applied on all pins of the device until a functional disturbance occurs. This test conforms with the IEC 61000-4-2 standard.
- FTB: A burst of fast transient voltage (positive and negative) is applied to V_{DD} and V_{SS} through a 100 pF capacitor, until a functional disturbance occurs. This test conforms with the IEC 61000-4-4 standard.

A device reset allows normal operations to be resumed. The test results are given in the table below based on the EMS levels and classes defined in application note AN1709 (EMC design guide for STMicrocontrollers).

10.3.12.2 Designing hardened software to avoid noise problems

EMC characterization and optimization are performed at component level with a typical application environment and simplified MCU software. It should be noted that good EMC performance is highly dependent on the user application and the software in particular.

Therefore it is recommended that the user applies EMC software optimization and prequalification tests in relation with the EMC level requested for his application.

Software recommendations

The software flowchart must include the management of runaway conditions such as:

- Corrupted program counter
- Unexpected reset
- Critical data corruption (control registers...)

Prequalification trials

Most of the common failures (unexpected reset and program counter corruption) can be recovered by applying a low state on the NRST pin or the oscillator pins for 1 second.

To complete these trials, ESD stress can be applied directly on the device, over the range of specification values. When unexpected behavior is detected, the software can be hardened to prevent unrecoverable errors occurring. See application note AN1015 (Software techniques for improving microcontroller EMC performance).

Table 48: EMS data

Symbol	Parameter	Conditions	Level/class
V_{FESD}	Voltage limits to be applied on any I/O pin to induce a functional disturbance	$V_{DD} = 5\text{ V}$, $T_A = 25\text{ °C}$, $f_{MASTER} = 16\text{ MHz}$, conforming to IEC 1000-4-2	2/B ⁽¹⁾
V_{EFTB}	Fast transient voltage burst limits to be applied through 100 pF on V_{DD}	$V_{DD} = 5\text{ V}$, $T_A = 25\text{ °C}$, $f_{MASTER} = 16\text{ MHz}$, conforming to IEC 1000-4-4	4/A ⁽¹⁾

Symbol	Parameter	Conditions	Level/class
	and V _{SS} pins to induce a functional disturbance		

⁽¹⁾Data obtained with HSI clock configuration, after applying HW recommendations described in AN2860 (EMC guidelines for STM8S microcontrollers).

10.3.12.3 Electromagnetic interference (EMI)

Emission tests conform to the IEC61967-2 standard for test software, board layout and pin loading.

Table 49: EMI data

Symbol	Parameter	Conditions				Unit
		General conditions	Monitored frequency band	Max f _{HSE} /f _{CPU} ⁽¹⁾		
				8 MHz/ 8 MHz	8 MHz/ 16 MHz	
S _{EMI}	Peak level	V _{DD} = 5 V, T _A = +25 °C, LQFP48 package conforming to IEC61967-2	0.1 MHz to 30 MHz	13	14	dBμV
			30 MHz to 130 MHz	23	19	
			130 MHz to 1 GHz	-4.0	-4.0	
	SAE EMI level		2.0	1.5	—	

⁽¹⁾ Data based on characterization results, not tested in production.

10.3.12.4 Absolute maximum ratings (electrical sensitivity)

Based on two different tests (ESD and LU) using specific measurement methods, the product is stressed in order to determine its performance in terms of electrical sensitivity. For more details, refer to the application note AN1181.

10.3.12.5 Electrostatic discharge (ESD)

Electrostatic discharges (3 positive then 3 negative pulses separated by 1 second) are applied to the pins of each sample according to each pin combination. The sample size depends on the number of supply pins in the device (3 parts*(n+1) supply pin). This test conforms to the JESD22-A114A/A115A standard. For more details, refer to the application note AN1181.

Table 50: ESD absolute maximum ratings

Symbol	Ratings	Conditions	Class	Maximum value ⁽¹⁾	Unit
V _{ESD(HBM)}	Electrostatic discharge voltage (Human body model)	T _A = +25°C, conforming to JESD22-A114	A	2000	V
V _{ESD(CDM)}	Electrostatic discharge voltage (Charge device model)	T _A =+25°C, conforming to JESD22-C101	IV	1000	V

⁽¹⁾ Data based on characterization results, not tested in production

10.3.12.6 Static latch-up

Two complementary static tests are required on 10 parts to assess the latch-up performance:

- A supply overvoltage (applied to each power supply pin)
- A current injection (applied to each input, output and configurable I/O pin) are performed on each sample.

This test conforms to the EIA/JESD 78 IC latch-up standard. For more details, refer to the application note AN1181.

Table 51: Electrical sensitivities

Symbol	Parameter	Conditions	Class ⁽¹⁾
LU	Static latch-up class	T _A = +25 °C	A
		T _A = +85 °C	A
		T _A = +125 °C	A

⁽¹⁾ Class description: A Class is an STMicroelectronics internal specification. All its limits are higher than the JEDEC specifications, that means when a device belongs to class A it exceeds the JEDEC standard. B class strictly covers all the JEDEC criteria (international standard).

11 Package information

In order to meet environmental requirements, ST offers these devices in different grades of ECOPACK[®] packages, depending on their level of environmental compliance. ECOPACK[®] specifications, grade definitions and product status are available at: www.st.com. ECOPACK[®] is an ST trademark.

11.1 48-pin LQFP package mechanical data

Figure 47: 48-pin low profile quad flat package (7 x 7)

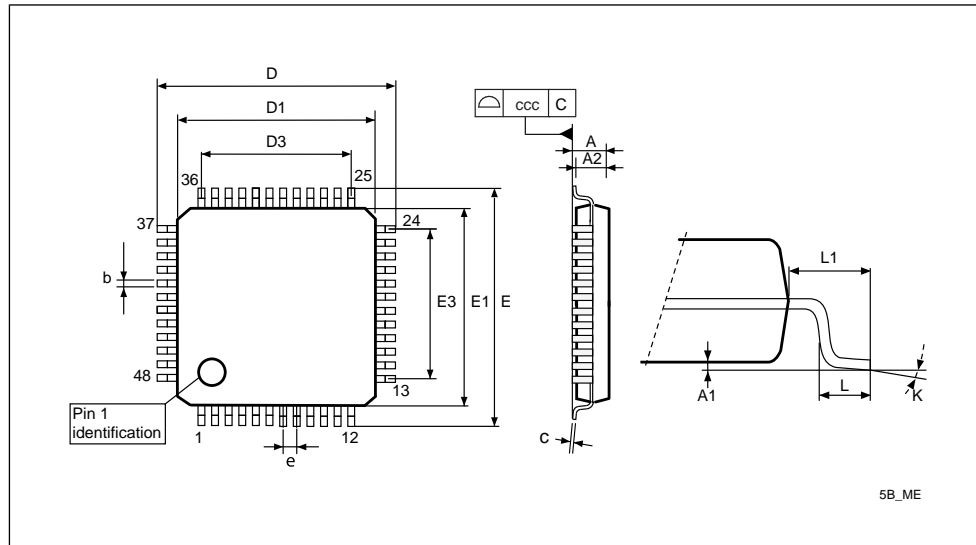

Table 52: 48-pin low profile quad flat package mechanical data

Dim.	mm			inches ⁽¹⁾		
	Min	Typ	Max	Min	Typ	Max
A			1.600			0.0630
A1	0.050		0.150	0.0020		0.0059
A2	1.350	1.400	1.450	0.0531	0.0551	0.0571
b	0.170	0.220	0.270	0.0067	0.0087	0.0106
c	0.090		0.200	0.0035		0.0079
D	8.800	9.000	9.200	0.3465	0.3543	0.3622

Dim.	mm			inches ⁽¹⁾		
	Min	Typ	Max	Min	Typ	Max
D1	6.800	7.000	7.200	0.2677	0.2756	0.2835
D3		5.500			0.2165	
E	8.800	9.000	9.200	0.3465	0.3543	0.3622
E1	6.800	7.000	7.200	0.2677	0.2756	0.2835
E3		5.500			0.2165	
e		0.500			0.0197	
L	0.450	0.600	0.750	0.0177	0.0236	0.0295
L1		1.000			0.0394	
k	0°	3.5°	7.0°	0°	3.5°	7.0°
ccc			0.080			0.0031

⁽¹⁾ Values in inches are converted from mm and rounded to 4 decimal digits

11.2 44-pin LQFP package mechanical data

Figure 48: 44-pin low profile quad flat package

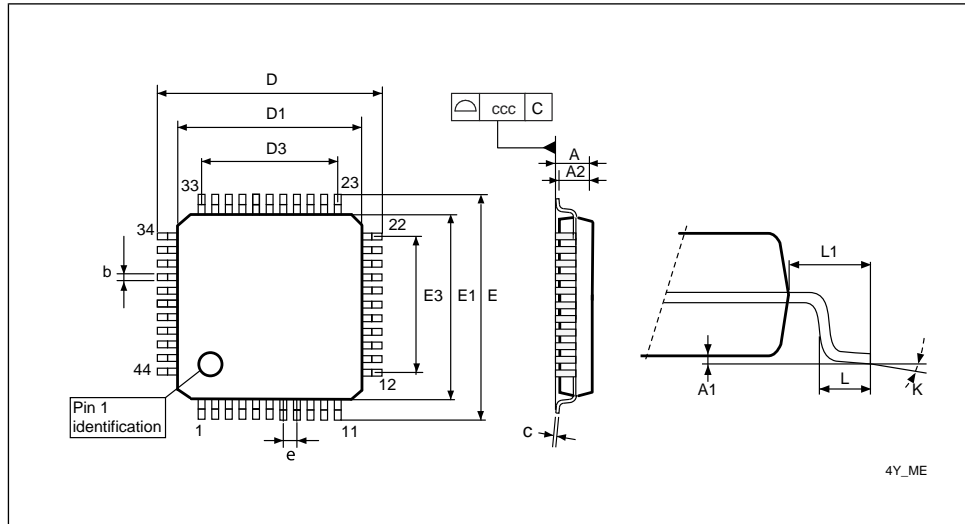

Table 53: 44-pin low profile quad flat package mechanical data

Dim.	mm			inches ⁽¹⁾		
	Min	Typ	Max	Min	Typ	Max
A			1.600			0.0630
A1	0.050		0.150	0.0020		0.0059
A2	1.350	1.400	1.450	0.0531	0.0551	0.0571
b	0.300	0.370	0.450	0.0118	0.0146	0.0177
c	0.090		0.200	0.0035		0.0079
D	11.800	12.000	12.200	0.4646	0.4724	0.4803
D1	9.800	10.000	10.200	0.3858	0.3937	0.4016
D3		8.000			0.3150	
E	11.800	12.000	12.200	0.4646	0.4724	0.4803

Dim.	mm			inches ⁽¹⁾		
	Min	Typ	Max	Min	Typ	Max
E1	9.800	10.000	10.200	0.3858	0.3937	0.4016
E3		8.000			0.3150	
e		0.800			0.0315	
L	0.450	0.600	0.750	0.0177	0.0236	0.0295
L1		1.000			0.0394	
k	0.0°	3.5°	7.0°	0.0°	3.5°	7.0°
ccc			0.100			0.0039

(1) Values in inches are converted from mm and rounded to 4 decimal digits

11.3 32-pin LQFP package mechanical data

Figure 49: 32-pin low profile quad flat package (7 x 7)

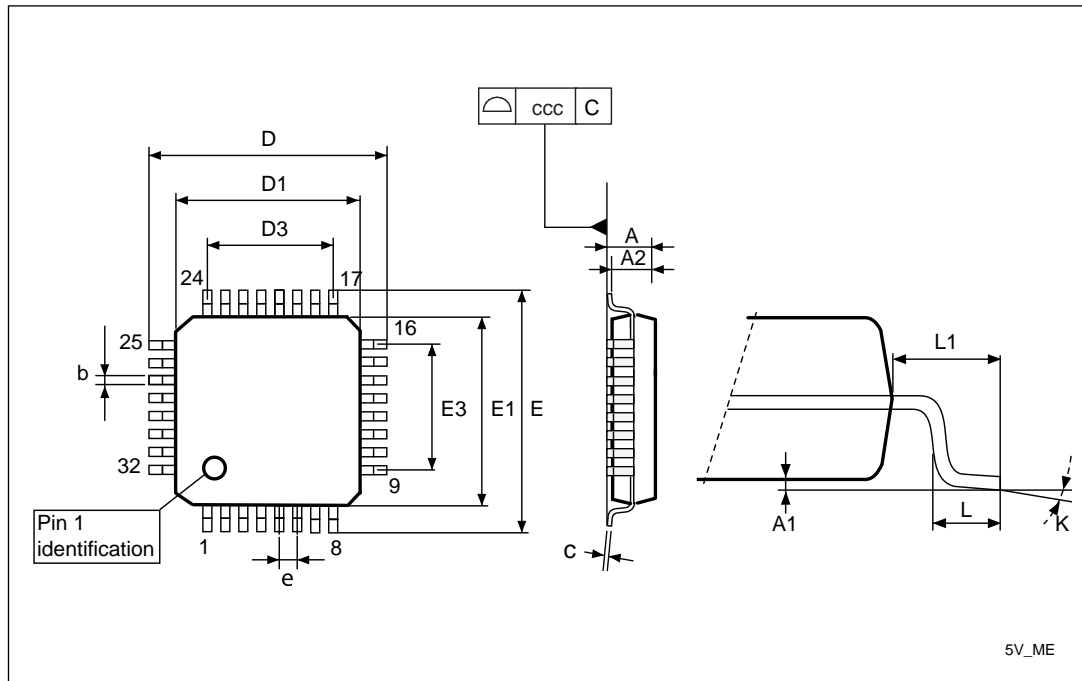

Table 54: 32-pin low profile quad flat package mechanical data

Dim.	mm			inches ⁽¹⁾		
	Min	Typ	Max	Min	Typ	Max
A			1.600			0.0630
A1	0.050		0.150	0.0020		0.0059
A2	1.350	1.400	1.450	0.0531	0.0551	0.0571
b	0.300	0.370	0.450	0.0118	0.0146	0.0177
c	0.090		0.200	0.0035		0.0079
D	8.800	9.000	9.200	0.3465	0.3543	0.3622
D1	6.800	7.000	7.200	0.2677	0.2756	0.2835
D3		5.600			0.2205	
E	8.800	9.000	9.200	0.3465	0.3543	0.3622
E1	6.800	7.000	7.200	0.2677	0.2756	0.2835
E3		5.600			0.2205	
e		0.800			0.0315	
L	0.450	0.600	0.750	0.0177	0.0236	0.0295
L1		1.000			0.0394	
k	0°	3.5°	7.0°	0°	3.5°	7.0°
ccc			0.100			0.0039

⁽¹⁾ Values in inches are converted from mm and rounded to 4 decimal digits

11.4 32-lead UFQFPN package mechanical data

Figure 50: 32-lead, ultra thin, fine pitch quad flat no-lead package (5 x 5)

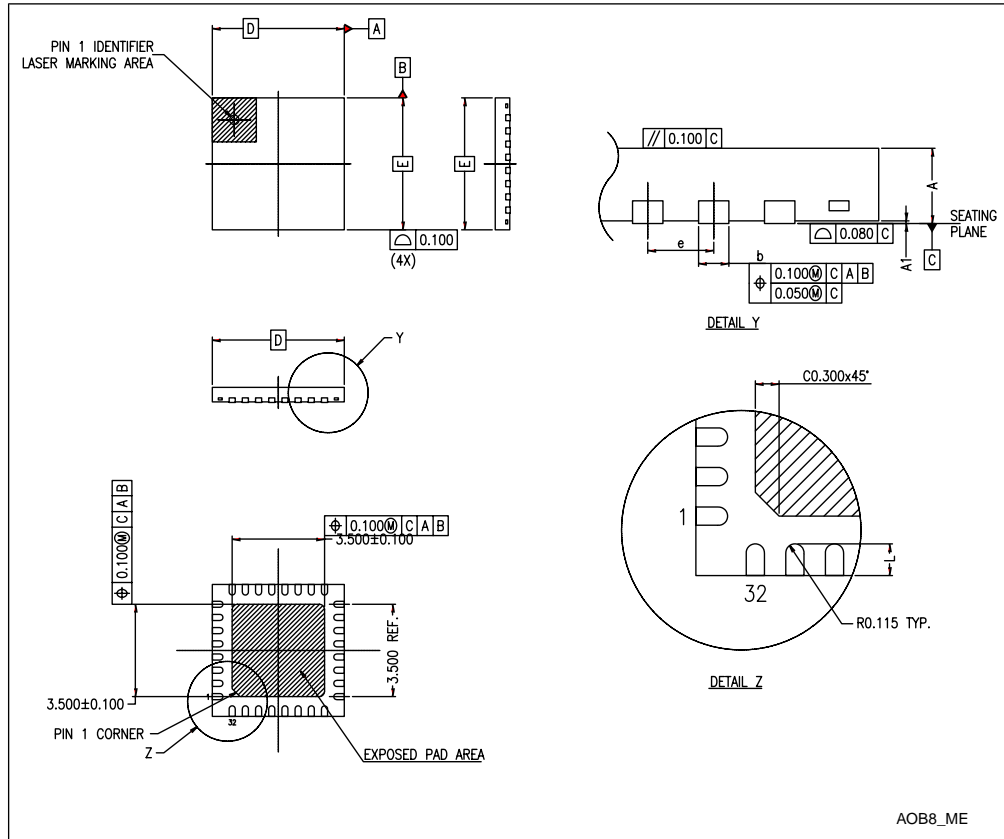

1. Drawing is not to scale.
2. All leads/pads should be soldered to the PCB to improve the lead/pad solder joint life.
3. There is an exposed die pad on the underside of the UFQFPN package. It is recommended to connect and solder this backside pad to PCB ground.
4. Dimensions are in millimeters.

Table 55: 32-lead, ultra thin, fine pitch quad flat no-lead package mechanical data

Dim.	mm			inches ⁽¹⁾		
	Min	Typ	Max	Min	Typ	Max
A	0.500	0.550	0.600	0.0197	0.0217	0.0236
A1	0	0.020	0.050		0.0008	0.0020
A3		0.200			0.0079	
b	0.180	0.250	0.300	0.0071	0.0098	0.0118

Dim.	mm			inches ⁽¹⁾		
	Min	Typ	Max	Min	Typ	Max
D	4.850	5.000	5.150	0.1909	0.1969	0.2028
D2	3.200	3.450	3.700	0.1260		0.1457
E	4.850	5.000	5.150	0.1909	0.1969	0.2028
E2	3.200	3.450	3.700	0.1260	0.1358	0.1457
e		0.500			0.0197	
L	0.300	0.400	0.500	0.0118	0.0157	0.0197
ddd			0.080			0.0031

⁽¹⁾ Values in inches are converted from mm and rounded to 4 decimal digits.

11.5 SDIP32 package mechanical data

Figure 51: 32-lead shrink plastic DIP (400 ml) package

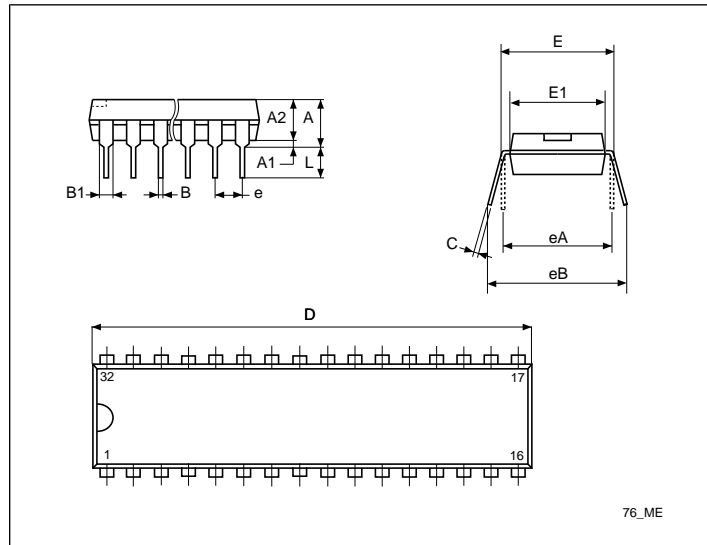

Table 56: 32-lead shrink plastic DIP (400 ml) package mechanical data

Dim.	mm			inches ⁽¹⁾		
	Min	Typ	Max	Min	Typ	Max
A	3.556	3.759	5.080	0.1400	0.1480	0.2000

Dim.	mm			inches ⁽¹⁾		
	Min	Typ	Max	Min	Typ	Max
A1	0.508			0.0200		
A2	3.048	3.556	4.572	0.1200	0.1400	0.1800
B	0.356	0.457	0.584	0.0140	0.0180	0.0230
B1	0.762	1.016	1.397	0.0300	0.0400	0.0550
C	0.203	0.254	0.356	0.0079	0.0100	0.0140
D	27.430	27.940	28.450	1.0799	1.1000	1.1201
E	9.906	10.410	11.050	0.3900	0.4098	0.4350
E1	7.620	8.890	9.398	0.3000	0.3500	0.3700
e		1.778			0.0700	
eA		10.160			0.4000	
eB			12.700			0.5000
L	2.540	3.048	3.810	0.1000	0.1200	0.1500

⁽¹⁾ Values in inches are converted from mm and rounded to 4 decimal digits

12 Thermal characteristics

The maximum chip junction temperature (T_{Jmax}) must never exceed the values given in [Operating conditions](#)

The maximum chip-junction temperature, T_{Jmax} , in degrees Celsius, may be calculated using the following equation:

$$T_{Jmax} = T_{Amax} + (P_{Dmax} \times \Theta_{JA})$$

Where:

- T_{Amax} is the maximum ambient temperature in °C
- Θ_{JA} is the package junction-to-ambient thermal resistance in °C/W
- P_{Dmax} is the sum of P_{INTmax} and $P_{I/Omax}$ ($P_{Dmax} = P_{INTmax} + P_{I/Omax}$)
- P_{INTmax} is the product of I_{DD} and V_{DD} , expressed in Watts. This is the maximum chip internal power.
- $P_{I/Omax}$ represents the maximum power dissipation on output pins Where: $P_{I/Omax} = \sum (V_{OL} * I_{OL}) + \sum ((V_{DD} - V_{OH}) * I_{OH})$, taking into account the actual V_{OL}/I_{OL} and V_{OH}/I_{OH} of the I/Os at low and high level in the application.

Table 57: Thermal characteristics⁽¹⁾

Symbol	Parameter	Value	Unit
Θ_{JA}	Thermal resistance junction-ambient LQFP 48 - 7 x 7 mm	57	°C/W
Θ_{JA}	Thermal resistance junction-ambient LQFP 44 - 10 x 10 mm	54	°C/W
Θ_{JA}	Thermal resistance junction-ambient LQFP 32 - 7 x 7 mm	60	°C/W
Θ_{JA}	Thermal resistance junction-ambient UFQFPN 32 - 5 x 5 mm	38	°C/W
Θ_{JA}	Thermal resistance junction-ambient SDIP 32 - 400 mils	60	°C/W

1. Thermal resistances are based on JEDEC JESD51-2 with 4-layer PCB in a natural convection environment.

12.1 Reference document

JESD51-2 integrated circuits thermal test method environment conditions - natural convection (still air). Available from www.jedec.org.

12.2 Selecting the product temperature range

When ordering the microcontroller, the temperature range is specified in the order code.

The following example shows how to calculate the temperature range needed for a given application.

Assuming the following application conditions:

- Maximum ambient temperature $T_{Amax} = 82\text{ }^{\circ}\text{C}$ (measured according to JESD51-2)
- $I_{DDmax} = 15\text{ mA}$, $V_{DD} = 5.5\text{ V}$
- Maximum 8 standard I/Os used at the same time in output at low level with $I_{OL} = 10\text{ mA}$, $V_{OL} = 2\text{ V}$
- Maximum 4 high sink I/Os used at the same time in output at low level with $I_{OL} = 20\text{ mA}$, $V_{OL} = 1.5\text{ V}$
- Maximum 2 true open drain I/Os used at the same time in output at low level with $I_{OL} = 20\text{ mA}$, $V_{OL} = 2\text{ V}$

$$P_{INTmax} = 15\text{ mA} \times 5.5\text{ V} = 82.5\text{ mW}$$

$$P_{IOmax} = (10\text{ mA} \times 2\text{ V} \times 8) + (20\text{ mA} \times 2\text{ V} \times 2) + (20\text{ mA} \times 1.5\text{ V} \times 4) = 360\text{ mW}$$

This gives: $P_{INTmax} = 82.5\text{ mW}$ and $P_{IOmax} = 360\text{ mW}$:

$$P_{Dmax} = 82.5\text{ mW} + 360\text{ mW}$$

$$\text{Thus: } P_{Dmax} = 443\text{ mW}$$

T_{Jmax} for LQFP32 can be calculated as follows, using the thermal resistance Θ_{JA} :

$$T_{Jmax} = 82\text{ }^{\circ}\text{C} + (60\text{ }^{\circ}\text{C/W} \times 443\text{ mW}) = 82\text{ }^{\circ}\text{C} + 27\text{ }^{\circ}\text{C} = 109\text{ }^{\circ}\text{C}$$

This is within the range of the suffix 3 version parts ($-40 < T_J < 131\text{ }^{\circ}\text{C}$). In this case, parts must be ordered at least with the temperature range suffix 3.

13 Ordering information

Figure 52: STM8S105xx access line ordering information scheme

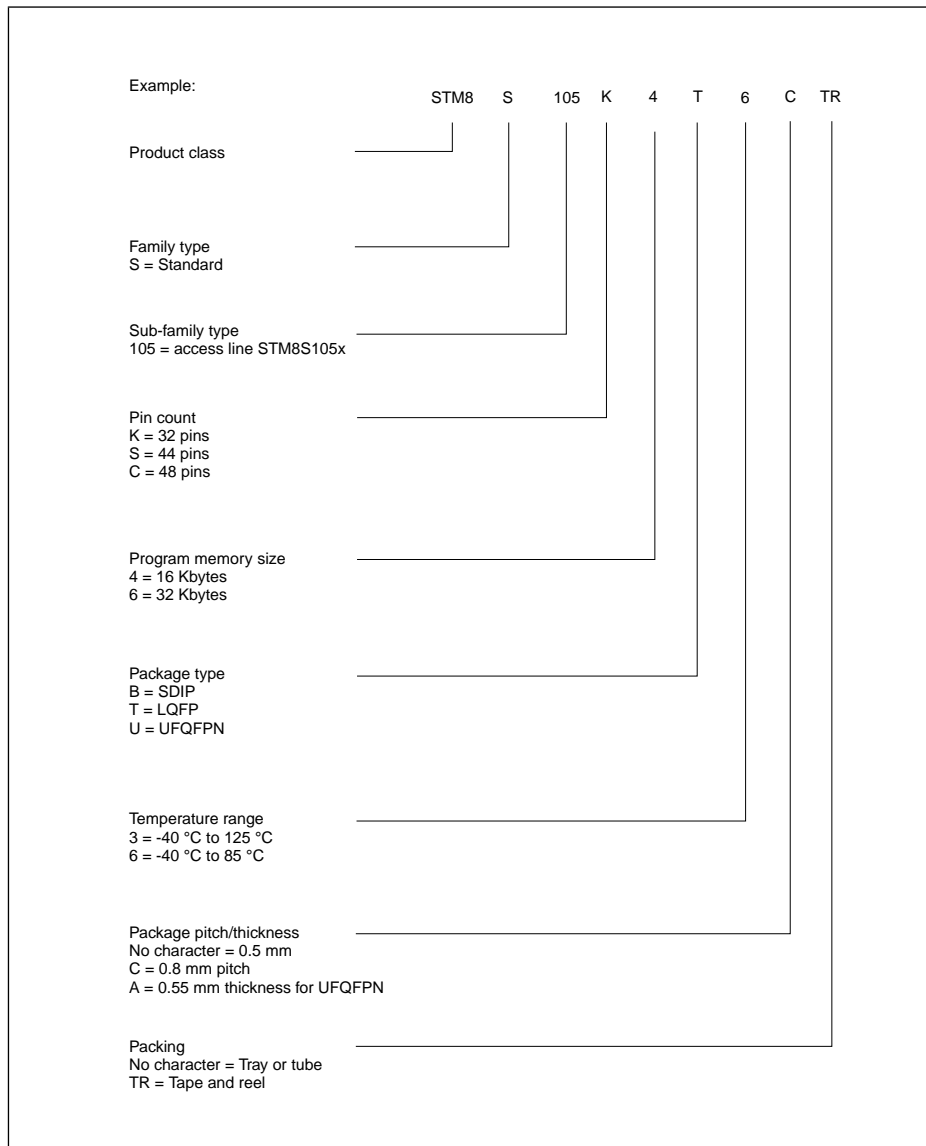

1. For a list of available options (e.g. memory size, package) and orderable part numbers or for further information on any aspect of this device, please go to www.st.com or contact the ST sales office nearest to you.

13.1 STM8S105 FASTROM microcontroller option list

(last update: September 2010)

Customer
Address

Contact
Phone no.
Reference FASTROM code ^a

Preferable format for programing code is .Hex (.s19 is accepted)

If data EEPROM programing is required, a seperate file must be sent with the requested data.

 **Important:** See the option byte section in the datasheet for authorized option byte combinations and a detailed explanation.

Device type/memory size/package (check only one option)

FASTROM device	16 Kbyte	32 Kbyte
LQFP32	<input type="checkbox"/> STM8S105K4	<input type="checkbox"/> STM8S105K6
LQFP44	<input type="checkbox"/> STM8S105S4	<input type="checkbox"/> STM8S105S6
LQFP48	<input type="checkbox"/> STM8S105C4	<input type="checkbox"/> STM8S105C6

Conditioning (check only one option)

Tape & reel or Tray

Special marking (check only one option)

No Yes

Authorized characters are letters, digits, '.', '-', '/' and spaces only. Maximum character counts are:

LQFP32: 2 lines of 7 characters max: " _____ " and " _____ "

LQFP44: 2 lines of 7 characters max: " _____ " and " _____ "

LQFP48: 2 lines of 8 characters max: " _____ " and " _____ "

Temperature range

-40°C to +85°C or -40°C to +125°C

Padding value for unused program memory (check only one option)

<input type="checkbox"/> 0xFF	Fixed value
<input type="checkbox"/> 0x83	TRAP instruction opcode
<input type="checkbox"/> 0x75	Illegal opcode (causes a reset when executed)

OPT0 memory readout protection (check only one option)

Disable or Enable

OPT1 user boot code area (UBC)

0x(_) fill in the hexadecimal value, referring to the datasheet and the binary format below.

UBC, bit0	<input type="checkbox"/> 0: Reset
-----------	-----------------------------------

^a FASTROM code name is assigned by STMicroelectronics.

	<input type="checkbox"/> 1: Set
UBC bit1	<input type="checkbox"/> 0: Reset <input type="checkbox"/> 1: Set
UBC bit2	<input type="checkbox"/> 0: Reset <input type="checkbox"/> 1: Set
UBC bit3	<input type="checkbox"/> 0: Reset <input type="checkbox"/> 1: Set
UBC bit4	<input type="checkbox"/> 0: Reset <input type="checkbox"/> 1: Set
UBC bit5	<input type="checkbox"/> 0: Reset <input type="checkbox"/> 1: Set

OPT2 alternate function remapping

AFR0 (check only one option)	<input type="checkbox"/> 0: Remapping option inactive. Default alternate functions used. Refer to pinout description. <input type="checkbox"/> 1: Port D3 alternate function = ADC_ETR
AFR1 (check only one option)	<input type="checkbox"/> 0: Remapping option inactive. Default alternate functions used. Refer to pinout description. <input type="checkbox"/> 1: Port A3 alternate function = TIM3_CH1, port D2 alternate function = TIM2_CH3.
AFR2 (check only one option)	<input type="checkbox"/> 0: Remapping option inactive. Default alternate functions used. Refer to pinout description. <input type="checkbox"/> 1: Port D0 alternate function = CLK_CCO.  Note: If both AFR2 and AFR3 are activated, AFR2 option has priority over AFR3.
AFR3 (check only one option)	<input type="checkbox"/> 0: Remapping option inactive. Default alternate functions used. Refer to pinout description. <input type="checkbox"/> 1: Port D0 alternate function = TIM1_BKIN.
AFR4 (check only one option)	<input type="checkbox"/> 0: Remapping option inactive. Default alternate functions used. Refer to pinout description. <input type="checkbox"/> 1: Port D7 alternate function = TIM1_CH4.
AFR5 (check only one option)	<input type="checkbox"/> 0: Remapping option inactive. Default alternate functions used. Refer to pinout description.

	<input type="checkbox"/> 1: Port B3 alternate function = TIM1_ETR, port B2 alternate function = TIM1_NCC3, port B1 alternate function = TIM1_CH2N, port B0 alternate function = TIM1_CH1N.
AFR6 (check only one option)	<input type="checkbox"/> 0: Remapping option inactive. Default alternate functions used. Refer to pinout description <input type="checkbox"/> 1: Port B5 alternate function = I2C_SDA, port B4 alternate function = I2C_SCL.
AFR7 (check only one option)	<input type="checkbox"/> 0: Remapping option inactive. Default alternate functions used. Refer to pinout description. <input type="checkbox"/> 1: Port D4 alternate function = BEEP.

OPT3 watchdog

WWDG_HALT (check only one option)	<input type="checkbox"/> 0: No reset generated on halt if WWDG active. <input type="checkbox"/> 1: Reset generated on halt if WWDG active.
WWDG_HW (check only one option)	<input type="checkbox"/> 0: WWDG activated by software. <input type="checkbox"/> 1: WWDG activated by hardware.
IWDG_HW (check only one option)	<input type="checkbox"/> 0: IWDG activated by software. <input type="checkbox"/> 1: IWDG activated by hardware.
LSI_EN (check only one option)	<input type="checkbox"/> 0: LSI clock is not available as CPU clock source. <input type="checkbox"/> 1: LSI clock is available as CPU clock source.
HSITRIM (check only one option)	<input type="checkbox"/> 0: 3-bit trimming supported in CLK_HSITRIMR register. <input type="checkbox"/> 1: 4-bit trimming supported in CLK_HSITRIMR register.

OPT4 wakeup

PRSC (check only one option)	<input type="checkbox"/> for 16 MHz to 128 kHz prescaler. <input type="checkbox"/> for 8 MHz to 128 kHz prescaler. <input type="checkbox"/> for 4 MHz to 128 kHz prescaler.
CKAWUSEL (check only one option)	<input type="checkbox"/> 0: LSI clock source selected for AWU. <input type="checkbox"/> 1: HSE clock with prescaler selected as clock source for AWU.
EXTCLK (check only one option)	<input type="checkbox"/> 0: External crystal connected to OSCIN/OSCOU. <input type="checkbox"/> 1: External clock signal on OSCIN.

OPT5 crystal oscillator stabilization HSECNT (check only one option)

- 2048 HSE cycles
- 128 HSE cycles
- 8 HSE cycles
- 0.5 HSE cycles

OPT6 is reserved

OPT7 is reserved

OPTBL bootloader option byte (check only one option)

Refer to the UM0560 (STM8L/S bootloader manual) for more details.

- Disable (00h)
- Enable (55h)

Comments:
Supply operating range in the application:
Notes:
Date:
Signature:

14 STM8 development tools

Development tools for the STM8 microcontrollers include the full-featured STice emulation system supported by a complete software tool package including C compiler, assembler and integrated development environment with high-level language debugger. In addition, the STM8 is to be supported by a complete range of tools including starter kits, evaluation boards and a low-cost in-circuit debugger/programmer.

14.1 Emulation and in-circuit debugging tools

The STice emulation system offers a complete range of emulation and in-circuit debugging features on a platform that is designed for versatility and cost-effectiveness. In addition, STM8 application development is supported by a low-cost in-circuit debugger/programmer.

The STice is the fourth generation of full featured emulators from STMicroelectronics. It offers new advanced debugging capabilities including profiling and coverage to help detect and eliminate bottlenecks in application execution and dead code when fine tuning an application.

In addition, STice offers in-circuit debugging and programming of STM8 microcontrollers via the STM8 single wire interface module (SWIM), which allows non-intrusive debugging of an application while it runs on the target microcontroller.

For improved cost effectiveness, STice is based on a modular design that allows you to order exactly what you need to meet your development requirements and to adapt your emulation system to support existing and future ST microcontrollers.

STice key features

- Occurrence and time profiling and code coverage (new features)
- Advanced breakpoints with up to 4 levels of conditions
- Data breakpoints
- Program and data trace recording up to 128 KB records
- Read/write on the fly of memory during emulation
- In-circuit debugging/programming via SWIM protocol
- 8-bit probe analyzer
- 1 input and 2 output triggers
- Power supply follower managing application voltages between 1.62 to 5.5 V
- Modularity that allows you to specify the components you need to meet your development requirements and adapt to future requirements
- Supported by free software tools that include integrated development environment (IDE), programming software interface and assembler for STM8.

14.2 Software tools

STM8 development tools are supported by a complete, free software package from STMicroelectronics that includes ST Visual Develop (STVD) IDE and the ST Visual Programmer (STVP) software interface. STVD provides seamless integration of the Cosmic and Raisonance C compilers for STM8, which are available in a free version that outputs up to 16 Kbytes of code.

14.2.1 STM8 toolset

STM8 toolset with STVD integrated development environment and STVP programming software is available for free download at www.st.com/mcu. This package includes:

ST Visual Develop – Full-featured integrated development environment from ST, featuring

- Seamless integration of C and ASM toolsets
- Full-featured debugger
- Project management
- Syntax highlighting editor
- Integrated programming interface
- Support of advanced emulation features for STice such as code profiling and coverage

ST Visual Programmer (STVP) – Easy-to-use, unlimited graphical interface allowing read, write and verify of your STM8 microcontroller's Flash program memory, data EEPROM and option bytes. STVP also offers project mode for saving programming configurations and automating programming sequences.

14.2.2 C and assembly toolchains

Control of C and assembly toolchains is seamlessly integrated into the STVD integrated development environment, making it possible to configure and control the building of your application directly from an easy-to-use graphical interface.

Available toolchains include:

- **Cosmic C compiler for STM8** – Available in a free version that outputs up to 16 Kbytes of code. For more information, see www.cosmic-software.com.
- **Raisonance C compiler for STM8** – Available in a free version that outputs up to 16 Kbytes of code. For more information, see www.raisonance.com.
- **STM8 assembler linker** – Free assembly toolchain included in the STVD toolset, which allows you to assemble and link your application source code.

14.3 Programming tools

During the development cycle, STice provides in-circuit programming of the STM8 Flash microcontroller on your application board via the SWIM protocol. Additional tools are to include a low-cost in-circuit programmer as well as ST socket boards, which provide dedicated programming platforms with sockets for programming your STM8.

For production environments, programmers will include a complete range of gang and automated programming solutions from third-party tool developers already supplying programmers for the STM8 family.

15 Revision history

Table 58: Document revision history

Date	Revision	Changes
05-Jun-2008	1	Initial release.
23-Jun-2008	2	Corrected number of high sink outputs to 9 in I/Os on <i>Features</i> . Updated part numbers in <i>Table 2: STM8S105xx access line features</i> .
12-Aug-2008	3	Updated part numbers in <i>Table 2: STM8S105xx access line features</i> . USART renamed UART1, LINUART renamed UART2. Added Table 7: Pin-to-pin comparison of pin 7 to 12 in 32-pin access line devices.
17-Sep-2008	4	Removed STM8S102xx and STM8S104xx root part numbers corresponding to devices without data EEPROM. Updated STM8S103 pinout in Section 5.2 on page 29. Added low and medium density Flash memory categories. Added Note 1 in <i>Table 17: Current characteristics</i> . Updated <i>Table 12: Option bytes</i> .
05-Feb-2009	5	Updated STM8S103 pinout in Section 5.2 on page 29 Updated number of High Sink I/Os in pinout. TSSOP20 pinout modified (PD4 moved to pin 1 etc.) Added WFQFN20 package Updated <i>Option bytes</i> . Added <i>Memory and register map</i> .
27-Feb-2009	6	Removed STM8S103x products (separate STM8S103 datasheet created) Updated <i>Electrical characteristics</i> .
12-May-2009	7	Added SDIP32 silhouette and package to <i>Features</i> and <i>SDIP32 package mechanical data</i> ; updated <i>Pinout and pin description</i> . Updated V _{DD} range (2.95 V to 5.5 V) on <i>Features</i> . Amended name of package VQFPN32

Date	Revision	Changes
		<p>Added Table 5 on page 22 .</p> <p>Updated <i>Auto wakeup counter</i>.</p> <p>Updated pins 25, 30, and 31 in <i>Pinout and pin description</i>.</p> <p>Removed Table 7: Pin-to-pin comparison of pin 7 to 12 in 32-pin access line devices.</p> <p>Added <i>Table 14: Description of alternate function remapping bits [7:0] of OPT2</i>.</p> <p><i>Electrical characteristics</i>: Updated VCAP specifications; updated Table 15, Table 18, Table 20, Table 21, Table 22, Table 23, Table 24, Table 25, Table 26, Table 27, Table 29, Table 35, and Table 42; added current consumption curves ; removed Figure 20: typical HSE frequency vs fcpu @ 4 temperatures; updated Figure 13, Figure 14, Figure 15, Figure 16 and Figure 17 ; modified HSI accuracy in Table 33 ; added Figure 44 ; modified fSCK, tV(SO) and tV(MO) in Table 42 ; updated figures and tables of High speed internal RC oscillator (HSI) ; replaced Figure 23, Figure 24, Figure 26, and Figure 39 .</p> <p><i>Package information</i>: Updated <i>Table 57: Thermal characteristics(1)</i> and removed Table 57: Junction temperature range. Updated <i>Figure 52: STM8S105xx access line ordering information scheme</i>.</p>
10-Jun-2009	8	<p>Document status changed from “preliminary data” to “datasheet”.</p> <p>Standardized name of the VFQFPN package.</p> <p>Removed ‘wpu’ from I2C pins in <i>Pinout and pin description</i></p>
21-Apr-2010	9	<p>Added UFQFPN32 package silhouette to the title page.</p> <p><i>Features</i>: added unique ID.</p> <p><i>Clock controller</i>: updated bit positions for TIM2 and TIM3.</p> <p><i>Beeper</i>: added information about availability of the beeper output port through option bit AFR7.</p> <p><i>Analog-to-digital converter (ADC1)</i>: added a note concerning additional AIN12 analog input.</p> <p><i>STM8S105 pinouts and pin description</i>: added UFQFPN32 package details; updated default alternate function of PB2/AIN2[TIM1_CH3N] pin in the "Pin description for STM8S105 microcontrollers" table.</p> <p><i>Option bytes</i>: added description of STM8L bootloader option bytes to the option byte description table.</p>

Date	Revision	Changes
		<p>Added <i>Unique ID</i></p> <p><i>Operating conditions</i>: added introductory text; removed low power dissipation condition for T_A, replaced "C_{EXT}" by "VCAP", and added ESR and ESL data in table "general operating conditions".</p> <p><i>Total current consumption in halt mode</i>: replaced max value of $I_{DD(H)}$ at 85 °C from 20 μA to 25 μA for the condition "Flash in powerdown mode, HSI clock after wakeup in the table "total current consumption in halt mode at $V_{DD} = 5$ V.</p> <p><i>Low power mode wakeup times</i>: added first condition (0 to 16 MHz) for the $t_{WU(WFI)}$ parameter in the table "wakeup times".</p> <p><i>Internal clock sources and timing characteristics</i>: In the table "HSI oscillator characteristics", replaced min and max values of "ACC_{HSI} factory calibrated parameter" and removed footnote 4 concerning further characterization of results.</p> <p><i>Functional EMS (electromagnetic susceptibility)</i>: IEC 1000 replaced with IEC 61000.</p> <p><i>Designing hardened software to avoid noise problems</i>: IEC 1000 replaced with IEC 61000.</p> <p><i>Electromagnetic interference (EMI)</i>: SAE J 1752/3 replaced with IEC61967-2.</p> <p><i>Thermal characteristics</i>: Replaced the thermal resistance junction ambient temperature of LQFP32 7X7 mm from 59 °C to 60 °C in the thermal characteristics table.</p> <p>Added <i>32-lead UFQFPN package mechanical data</i>.</p> <p>Added <i>STM8S105 FASTROM microcontroller option list</i>.</p>
21-Sep-2010	10	<p><i>Table 5: Legend/abbreviations for pinout tables</i> : updated "reset state"; removed "HS", (T), and "[]".</p> <p><i>Table 6: Pin description for STM8S105 microcontrollers</i>: added footnotes to the PF4 and PD1 pins.</p> <p><i>Table 8: I/O port hardware register map</i>: changed reset status of P_x_IDR from 0x00 to 0xXX.</p> <p><i>Table 9: General hardware register map</i>: Standardized all address and reset state values; updated the reset state values of the RST_SR, CLK_SWCR, CLK_HSITRIMR, CLK_SWIMCCR, IWDG_KR, UART2_DR, and ADC_DRx registers; replaced reserved address "0x00 5248" with the UART2_CR5.</p> <p><i>Figure 40: Recommended reset pin protection</i>: replaced 0.01 μF with 0.1 μF</p>

Date	Revision	Changes
		<p>Updated Figure 44: Typical application with I2C bus and timing diagram (1) .</p> <p>Updated footnote 1 in Table 46: ADC accuracy with RAIN < 10 kΩ , VDDA= 5 V and Table 47: ADC accuracy with RAIN < 10 kΩ RAIN, VDDA = 3.3 V .</p> <p>STM8S105 FASTROM microcontroller option list: removed bits 6 and 7 from OPT1 user boot code area (UBC); added "disable" to 00h and "enable" to 55h of OPTBL bootloader option byte.</p> <p>Figure 50: 32-lead, ultra thin, fine pitch quad flat no-lead package (5 x 5): replaced note 1 and added note 2.</p>
04-Apr-2012	11	<p>Removed VFQFPN32 package.</p> <p>Modified Description.</p> <p>Remove weak pull-up input for PE1 and PE2 in Table 6: Pin description for STM8S105 microcontrollers</p> <p>Updated Table 11: Interrupt mapping for TIM2 and TIM4.</p> <p>Updated notes related to V_{CAP} in Table 19: General operating conditions.</p> <p>Added values of t_R/t_F for 50 pF load capacitance, and updated note in Table 38: I/O static characteristics.</p> <p>Updated typical and maximum values of R_{PU} in Table 38: I/O static characteristics and Table 42: NRST pin characteristics.</p> <p>Changed SCK input to SCK output in SPI serial peripheral interface</p> <p>Added Θ_{JA} for UFQFPN32 and SDIP32 in Table 57: Thermal characteristics(1) , and updated Selecting the product temperature range</p>
28-Jun-2012	12	<p>Added UFQFPN package thickness in Figure 52: STM8S105xx access line ordering information scheme.</p>

Please Read Carefully

Information in this document is provided solely in connection with ST products. STMicroelectronics NV and its subsidiaries ("ST") reserve the right to make changes, corrections, modifications or improvements, to this document, and the products and services described herein at anytime, without notice.

All ST products are sold pursuant to ST's terms and conditions of sale.

Purchasers are solely responsible for the choice, selection and use of the ST products and services described herein, and ST assumes no liability whatsoever relating to the choice, selection or use of the ST products and services described herein.

No license, express or implied, by estoppel or otherwise, to any intellectual property rights is granted under this document. If any part of this document refers to any third party products or services it shall not be deemed a license grant by ST for the use of such third party products or services, or any intellectual property contained therein or considered as a warranty covering the use in any manner whatsoever of such third party products or services or any intellectual property contained therein.

UNLESS OTHERWISE SET FORTH IN ST'S TERMS AND CONDITIONS OF SALE ST DISCLAIMS ANY EXPRESS OR IMPLIED WARRANTY WITH RESPECT TO THE USE AND/OR SALE OF ST PRODUCTS INCLUDING WITHOUT LIMITATION IMPLIED WARRANTIES OF MERCHANTABILITY, FITNESS FOR A PARTICULAR PURPOSE (AND THEIR EQUIVALENTS UNDER THE LAWS OF ANY JURISDICTION), OR INFRINGEMENT OF ANY PATENT, COPYRIGHT OR OTHER INTELLECTUAL PROPERTY RIGHT.

UNLESS EXPRESSLY APPROVED IN WRITING BY TWO AUTHORIZED ST REPRESENTATIVES, ST PRODUCTS ARE NOT RECOMMENDED, AUTHORIZED OR WARRANTED FOR USE IN MILITARY, AIR CRAFT, SPACE, LIFE SAVING, OR LIFE SUSTAINING APPLICATIONS, NOR IN PRODUCTS OR SYSTEMS WHERE FAILURE OR MALFUNCTION MAY RESULT IN PERSONAL INJURY, DEATH, OR SEVERE PROPERTY OR ENVIRONMENTAL DAMAGE. ST PRODUCTS WHICH ARE NOT SPECIFIED AS "AUTOMOTIVE GRADE" MAY ONLY BE USED IN AUTOMOTIVE APPLICATIONS AT USER'S OWN RISK.

Resale of ST products with provisions different from the statements and/or technical features set forth in this document shall immediately void any warranty granted by ST for the ST product or service described herein and shall not create or extend in any manner whatsoever, any liability of ST.

ST and the ST logo are trademarks or registered trademarks of ST in various countries.

Information in this document supersedes and replaces all information previously supplied.

The ST logo is a registered trademark of STMicroelectronics. All other names are the property of their respective owners.

© 2012 STMicroelectronics - All rights reserved

STMicroelectronics group of companies

Australia - Belgium - Brazil - Canada - China - Czech Republic - Finland - France - Germany - Hong Kong - India - Israel - Italy - Japan - Malaysia - Malta - Morocco - Philippines - Singapore - Spain - Sweden - Switzerland - United Kingdom - United States of America

www.st.com