



STM6321/6322 STM6821/6822/6823/6824/6825

5-Pin Supervisor with Watchdog Timer and Push-button Reset

Features

- Precision V_{CC} Monitoring of 5, 3.3, 3, or 2.5V Power Supplies
- \overline{RST} Outputs (Active-low, Push-pull or Open Drain)
- RST Outputs (Active-high, Push-pull)
- Reset Pulse Width of 1.4ms, 200ms and 240ms (typ) ^(a)
- Watchdog Timeout Period of 1.6s (typ) ^(a)
- Manual Reset Input (\overline{MR})
- Low Supply Current - 3 μ A (typ)
- Guaranteed \overline{RST} (RST) Assertion down to $V_{CC} = 1.0V$
- Operating Temperature: -40 to 85°C (Industrial Grade)
- RoHS Compliance
Lead-free Components are Compliant with the RoHS Directive.

Figure 1. Package

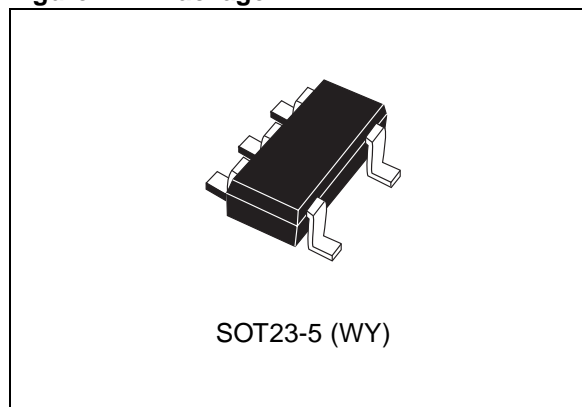

Table 1. Device Options

Part Number	Watchdog Input	Manual Reset Input	Reset Output		
			Active-Low (Push-pull)	Active-High (Push-pull)	Active-Low (Open Drain)
STM6321	✓			✓	✓
STM6322		✓		✓	✓
STM6821	✓	✓		✓	
STM6822	✓	✓			✓
STM6823	✓	✓	✓		
STM6824	✓		✓	✓	
STM6825		✓	✓	✓	

a. Other t_{rec} and watchdog timings are offered. Minimum order quantities may apply. Contact local sales office for availability.

Contents

1	Summary Description	5
1.1	Pin Descriptions	7
1.1.1	Active-low, Push-pull Reset Output ($\overline{\text{RST}}$) - STM6822/6823/6824/6825	7
1.1.2	Active-low, Open Drain Reset Output ($\overline{\text{RST}}$) - STM6321/6322/6822	7
1.1.3	Push-button Reset Input ($\overline{\text{MR}}$)	7
1.1.4	Watchdog Input (WDI)	7
1.1.5	Active-High Reset Output (RST)	7
2	Operation	10
2.1	Reset Output	10
2.2	Open Drain $\overline{\text{RST}}$ Output	10
2.3	Push-button Reset Input (STM6322/6821/6822/6823/6825)	11
2.4	Watchdog Input (STM6321/6821/6822/6823/6824)	11
2.5	Applications Information	11
2.5.1	Watchdog Input Current	11
2.5.2	Ensuring a Valid Reset Output Down to $V_{\text{CC}} = 0\text{V}$	11
2.6	Interfacing to Microprocessors with Bi-directional Reset Pins	12
3	Typical Operating Characteristics	13
4	Maximum Rating	18
5	DC and AC Parameters	19
6	Package Mechanical	22
7	Part Numbering	23
8	Revision History	25

List of Tables

Table 1.	Device Options	1
Table 2.	Signal Names	5
Table 3.	Pin Functions	7
Table 4.	Absolute Maximum Ratings	18
Table 5.	Operating and AC Measurement Conditions	19
Table 6.	DC and AC Characteristics	20
Table 7.	SOT23-5 – 5-lead Small Outline Transistor Package Mechanical Data	22
Table 8.	Ordering Information Scheme	23
Table 9.	Marking Description	24
Table 10.	Document Revision History	25

List of Figures

Figure 1.	Package	1
Figure 2.	Logic Diagram (STM6821/6822/6823)	5
Figure 3.	Logic Diagram (STM6321/6322/6824/6825)	5
Figure 4.	STM6822/6823 SOT23-5 Connections	6
Figure 5.	STM6821 SOT23-5 Connections	6
Figure 6.	STM6322/6825 SOT23-5 Connections	6
Figure 7.	STM6321/6824 SOT23-5 Connections	6
Figure 8.	Block Diagram (STM6821/6822/6823)	8
Figure 9.	Block Diagram (STM6321/6824)	8
Figure 10.	Block Diagram (STM6322/6825)	8
Figure 11.	Hardware Hookup	9
Figure 12.	STM6321/6322/6822 Open Drain $\overline{\text{RST}}$ Output with Multiple Supplies	10
Figure 13.	Ensuring $\overline{\text{RST}}$ Valid to $V_{\text{CC}} = 0$, (Active-Low Push-pull Outputs)	12
Figure 14.	Ensuring RST Valid to $V_{\text{CC}} = 0$, (Active-High, Push-pull Outputs)	12
Figure 15.	Interfacing to Microprocessors with Bi-directional Reset I/O	12
Figure 16.	V_{CC} -to-Reset Output Delay vs. Temperature	13
Figure 17.	Supply Current vs. Temperature	13
Figure 18.	$\overline{\text{MR}}$ -to-Reset Output Delay vs. Temperature	14
Figure 19.	Normalized Power-up t_{rec} vs. Temperature	14
Figure 20.	Normalized Reset Threshold Voltage vs. Temperature	15
Figure 21.	Normalized Power-up Watchdog Time-Out Period	15
Figure 22.	Voltage Output Low vs. I_{SINK}	16
Figure 23.	Voltage Output High vs. I_{SOURCE}	16
Figure 24.	Maximum Transient Duration vs. Reset Threshold Overdrive	17
Figure 25.	AC Testing Input/Output Waveforms	19
Figure 26.	$\overline{\text{MR}}$ Timing Waveform	19
Figure 27.	Watchdog Timing	19
Figure 28.	SOT23-5 – 5-lead Small Outline Transistor Package Mechanical Drawing	22

1 Summary Description

The STM6xxx Supervisors are self-contained devices which provide microprocessor supervisory functions. A precision voltage reference and comparator monitors the V_{CC} input for an out-of-tolerance condition. When an invalid V_{CC} condition occurs, the reset output (\overline{RST}) is forced low (or high in the case of RST). These devices also offer a watchdog timer (except for STM6322/6825) and/or a push-button (\overline{MR}) reset input.

These devices are available in a standard 5-pin SOT23 package.

Figure 2. Logic Diagram (STM6821/6822/6823)

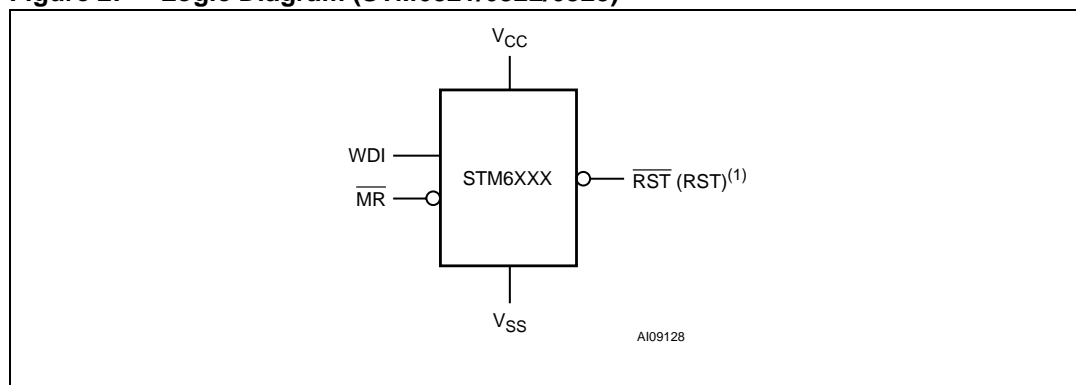

1. For STM6821 only.

Figure 3. Logic Diagram (STM6321/6322/6824/6825)

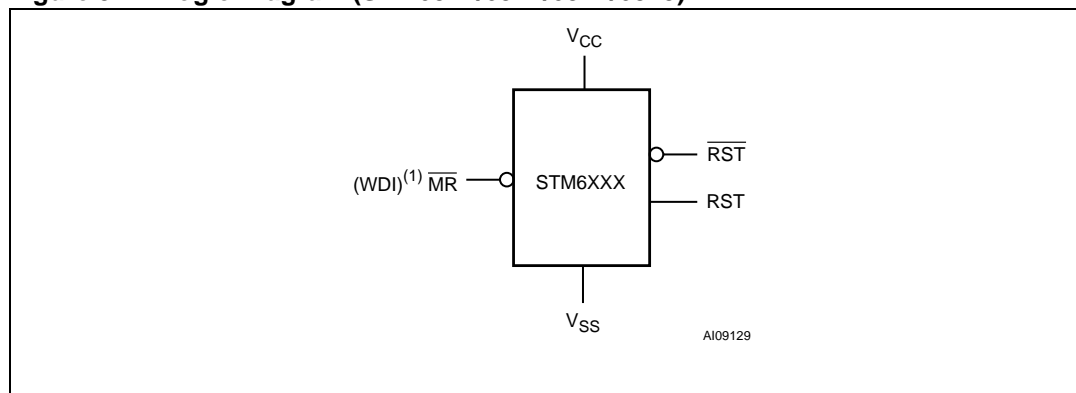

1. For STM6321/6824.

Table 2. Signal Names

\overline{MR}	Push-button Reset Input
WDI	Watchdog Input
\overline{RST}	Active-Low Reset Output
RST	Active-High Reset Output
V_{CC}	Supply Voltage
V_{SS}	Ground

Figure 4. STM6822/6823 SOT23-5 Connections

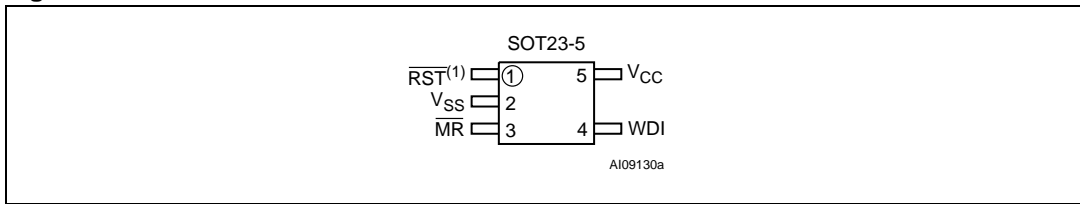

1. Open drain for STM6822.

Figure 5. STM6821 SOT23-5 Connections

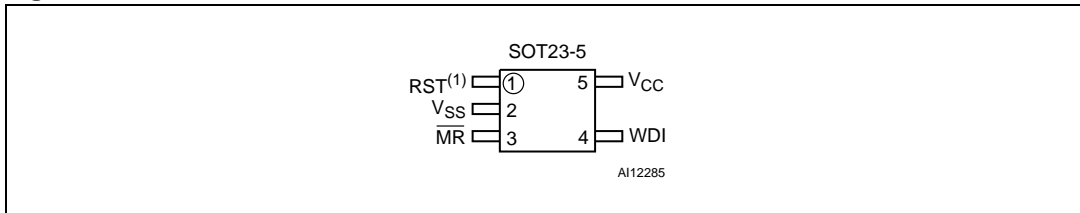

1. Push-pull only.

Figure 6. STM6322/6825 SOT23-5 Connections

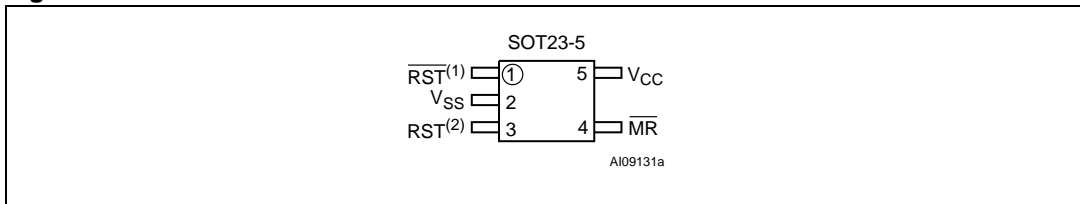

1. Open drain for STM6322.
2. Push-pull only.

Figure 7. STM6321/6824 SOT23-5 Connections

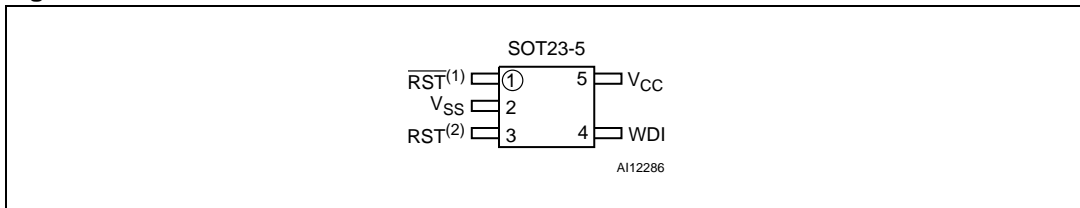

1. Open drain for STM6321.
2. Push-pull only.

1.1 Pin Descriptions

1.1.1 Active-low, Push-pull Reset Output (\overline{RST}) - STM6822/6823/6824/6825

Pulses low when triggered, and stays low whenever V_{CC} is below the reset threshold or when \overline{MR} is a logic low. It remains low for t_{rec} after either V_{CC} rises above the reset threshold, the watchdog triggers a reset, or \overline{MR} goes from low to high.

1.1.2 Active-low, Open Drain Reset Output (\overline{RST}) - STM6321/6322/6822

Pulses low when triggered, and stays low whenever V_{CC} is below the reset threshold or when \overline{MR} is a logic low. It remains low for t_{rec} after either V_{CC} rises above the reset threshold, the watchdog triggers a reset, or \overline{MR} goes from low to high. Connect a pull-up resistor to supply voltage.

1.1.3 Push-button Reset Input (\overline{MR})

A logic low on \overline{MR} asserts the reset output. Reset remains asserted as long as \overline{MR} is low and for t_{rec} after \overline{MR} returns high. This active-low input has an internal 52k Ω pull-up. It can be driven from a TTL or CMOS logic line, or shorted to ground with a switch. Leave open if unused.

1.1.4 Watchdog Input (WDI)

If WDI remains high or low for at least 1.6s, the internal watchdog timer expires and reset is asserted. The internal watchdog timer clears while reset is asserted or when WDI sees a rising or falling edge. The watchdog function **CAN** be disabled if WDI is left unconnected or is connected to a tri-state buffer output.

1.1.5 Active-High Reset Output (RST)

Active-high, push-pull reset output; inverse of \overline{RST} .

Table 3. Pin Functions

Pin				Name	Function
STM6822 STM6823	STM6821	STM6321 STM6824	STM6322 STM6825		
1	—	1	1	\overline{RST}	Active-Low Reset Output
3	3	—	4	\overline{MR}	Push-button Reset Input
4	4	4	—	WDI	Watchdog Input
—	1	3	3	RST	Active-High Reset Output
5	5	5	5	V_{CC}	Supply Voltage
2	2	2	2	V_{SS}	Ground

Figure 8. Block Diagram (STM6821/6822/6823)

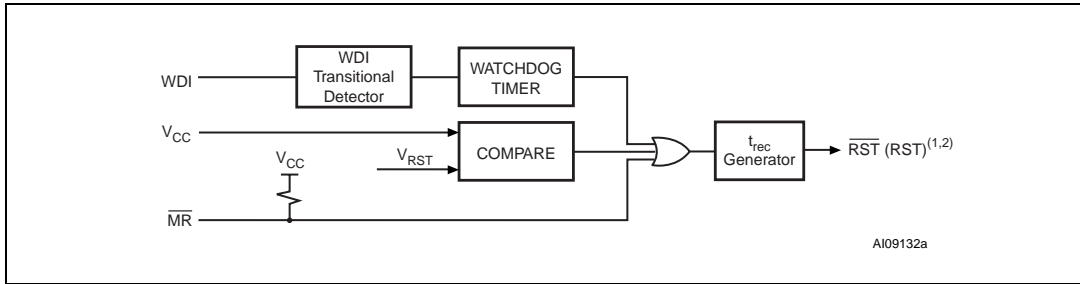

1. Push-pull for STM6823, open drain for STM6822.
2. Active-high (push-pull) for STM6821.

Figure 9. Block Diagram (STM6321/6824)

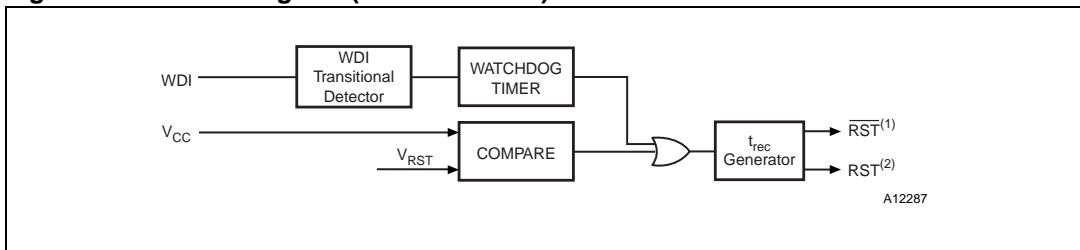

3. Active-low (open drain) for STM6321, active-low (push-pull) for STM6824.
4. Push-pull only.

Figure 10. Block Diagram (STM6322/6825)

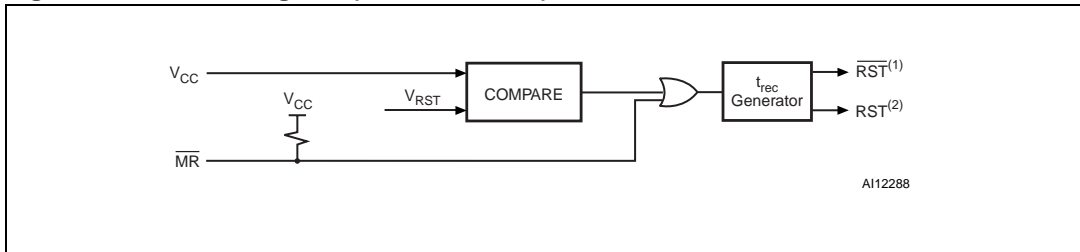

1. Active-low (open drain) for STM6322, active-low (push-pull) for STM6825.
2. Push-pull only.

Figure 11. Hardware Hookup

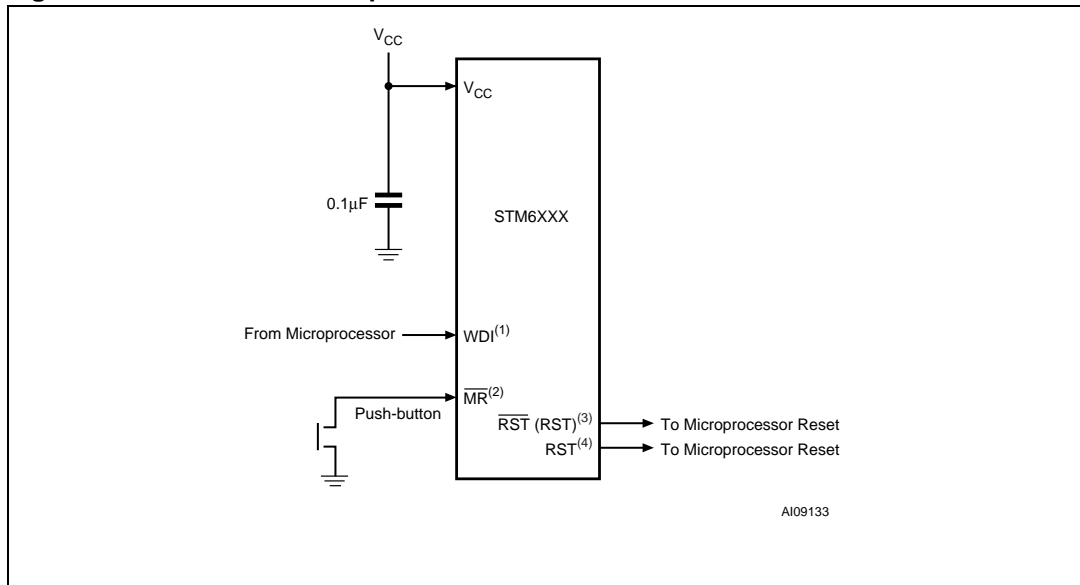

1. For STM6321/6821/6822/6823/6824
2. For STM6322/6821/6822/6823/6825
3. For STM6821/ (RST output only)
4. For STM6321/6322/6824/6825 (both RST and $\overline{\text{RST}}$ outputs)

2 Operation

2.1 Reset Output

The STM6xxx Supervisor asserts a reset signal to the MCU whenever V_{CC} goes below the reset threshold (V_{RST}), a watchdog time-out occurs, or when the Push-button Reset Input (\overline{MR}) is taken low. Reset is guaranteed valid for $V_{CC} < V_{RST}$ down to $V_{CC} = 1V$ for $T_A = 0^\circ C$ to $85^\circ C$.

During power-up, once V_{CC} exceeds the reset threshold an internal timer keeps reset low for the reset time-out period, t_{rec} . After this interval reset is de-asserted.

Each time \overline{RST} is asserted, it stays low for at least the reset time-out period (t_{rec}). Any time V_{CC} goes below the reset threshold the internal timer clears. The reset timer starts when V_{CC} returns above the reset threshold.

2.2 Open Drain \overline{RST} Output

The STM6321/6322/6822 have an active-low, open drain reset output. This output structure will sink current when \overline{RST} is asserted. Connect a pull-up resistor from \overline{RST} to any supply voltage up to 6V (see [Figure 12](#)). Select a resistor value large enough to register a logic low, and small enough to register a logic high while supplying all input current and leakage paths connected to the reset output line. A 10k Ω pull-up resistor is sufficient in most applications.

Figure 12. STM6321/6322/6822 Open Drain \overline{RST} Output with Multiple Supplies

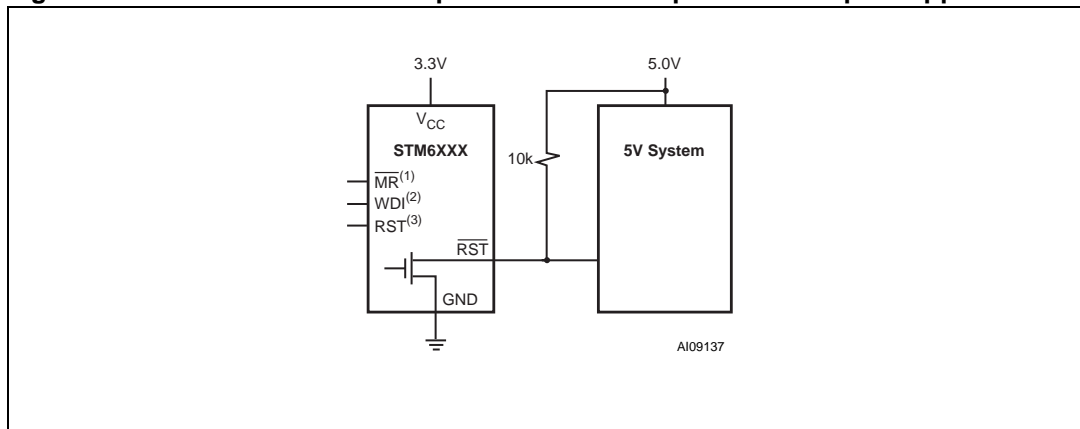

1. STM6322/6822
2. STM6321/6822
3. STM6321/6322

2.3 Push-button Reset Input (STM6322/6821/6822/6823/6825)

A logic low on \overline{MR} asserts reset. Reset remains asserted while \overline{MR} is low, and for t_{rec} (see [Figure 26 on page 19](#)) after it returns high. The MR input has an internal 52k Ω pull-up resistor, allowing it to be left open if not used. This input can be driven with TTL/CMOS-logic levels or with open-drain/collector outputs. Connect a normally open momentary switch from \overline{MR} to GND to create a manual reset function; external debounce circuitry is not required. If \overline{MR} is driven from long cables or the device is used in a noisy environment, connect a 0.1 μ F capacitor from \overline{MR} to GND to provide additional noise immunity. \overline{MR} may float, or be tied to V_{CC} when not used.

2.4 Watchdog Input (STM6321/6821/6822/6823/6824)

The watchdog timer can be used to detect an out-of-control MCU. If the MCU does not toggle the Watchdog Input (WDI) within t_{WD} (1.6sec), the reset is asserted. The internal watchdog timer is cleared by either:

1. a reset pulse, or
2. by toggling WDI (high-to-low or low-to-high), which can detect pulses as short as 50ns.

The timer remains cleared and does not count for as long as reset is asserted. As soon as reset is released, the timer starts counting.

Note: The watchdog function may be disabled by floating WDI or tri-stating the driver connected to WDI. When tri-stated or disconnected, the maximum allowable leakage current is 10 μ A and the maximum allowable load capacitance is 200pF.

2.5 Applications Information

2.5.1 Watchdog Input Current

The WDI input is internally driven through a buffer and series resistor from the watchdog counter. For minimum watchdog input current (minimum overall power consumption), leave WDI low for the majority of the watchdog time-out period. When high, WDI can draw as much as 160 μ A. Pulsing WDI high at a low duty cycle will reduce the effect of the large input current. When WDI is left unconnected, the watchdog timer is serviced within the watchdog time-out period by a low-high-low pulse from the counter chain.

2.5.2 Ensuring a Valid Reset Output Down to $V_{CC} = 0V$

The STM6xxx Supervisors are guaranteed to operate properly down to $V_{CC} = 1V$. In applications that require valid reset levels down to $V_{CC} = 0$, a pull-down resistor to active-low outputs (push/pull only, see [Figure 13 on page 12](#)) and a pull-up resistor to active-high outputs (push/pull only, see [Figure 14 on page 12](#)) will ensure that the reset line is valid while the reset output can no longer sink or source current. This scheme does not work with the open drain outputs of the STM6321/6322/6822.

The resistor value used is not critical, but it must be large enough not to load the reset output when V_{CC} is above the reset threshold. For most applications, 100k Ω is adequate.

Figure 13. Ensuring $\overline{\text{RST}}$ Valid to $V_{CC} = 0$, (Active-Low Push-pull Outputs)

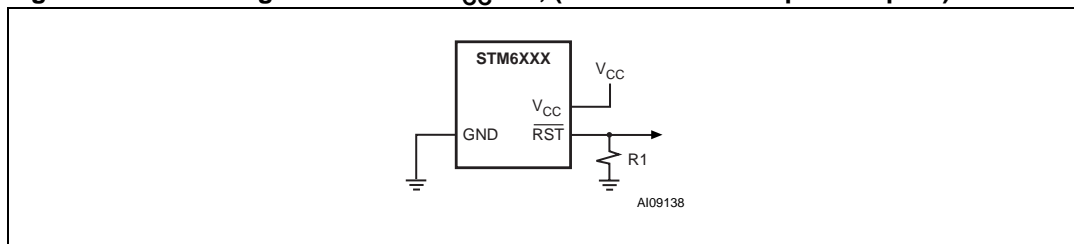
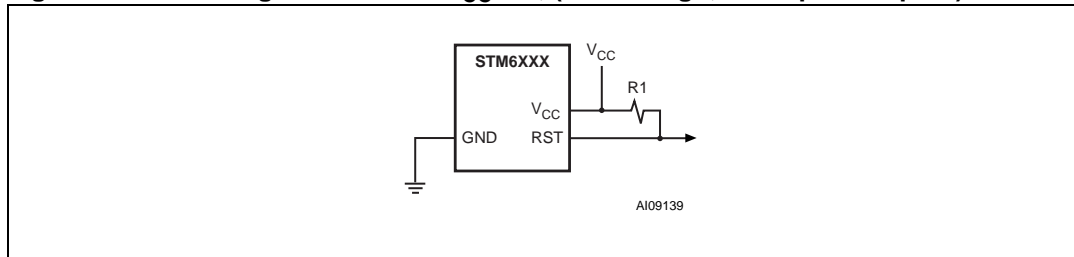

Figure 14. Ensuring RST Valid to $V_{CC} = 0$, (Active-High, Push-pull Outputs)



1. This configuration does not work on open drain outputs of the STM6321/6322/6822.

2.6 Interfacing to Microprocessors with Bi-directional Reset Pins

Microprocessors with bi-directional reset pins can contend with the STM6321/6322/6821/6822/6823/6824/6825 reset output. For example, if the reset output is driven high and the microprocessor wants to pull it low, signal contention will result. To prevent this from occurring, connect a 4.7kΩ resistor between the reset output and the microprocessor's reset I/O as in [Figure 15](#).

Figure 15. Interfacing to Microprocessors with Bi-directional Reset I/O

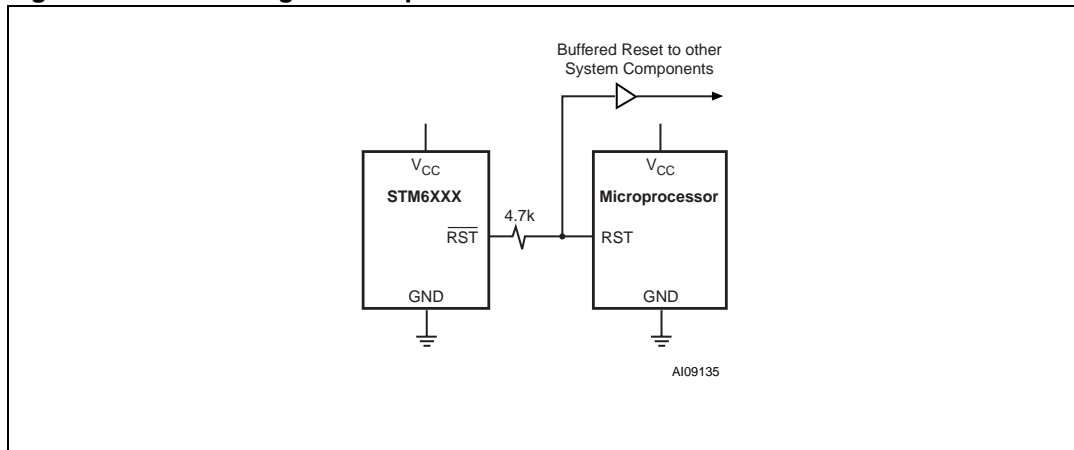

3 Typical Operating Characteristics

Figure 16. V_{CC} -to-Reset Output Delay vs. Temperature

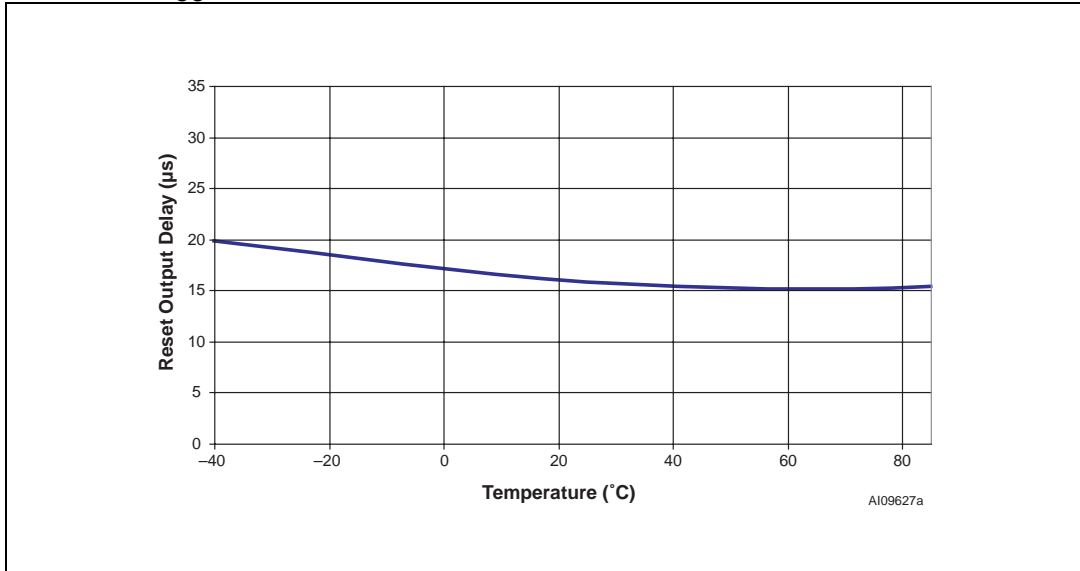

Figure 17. Supply Current vs. Temperature

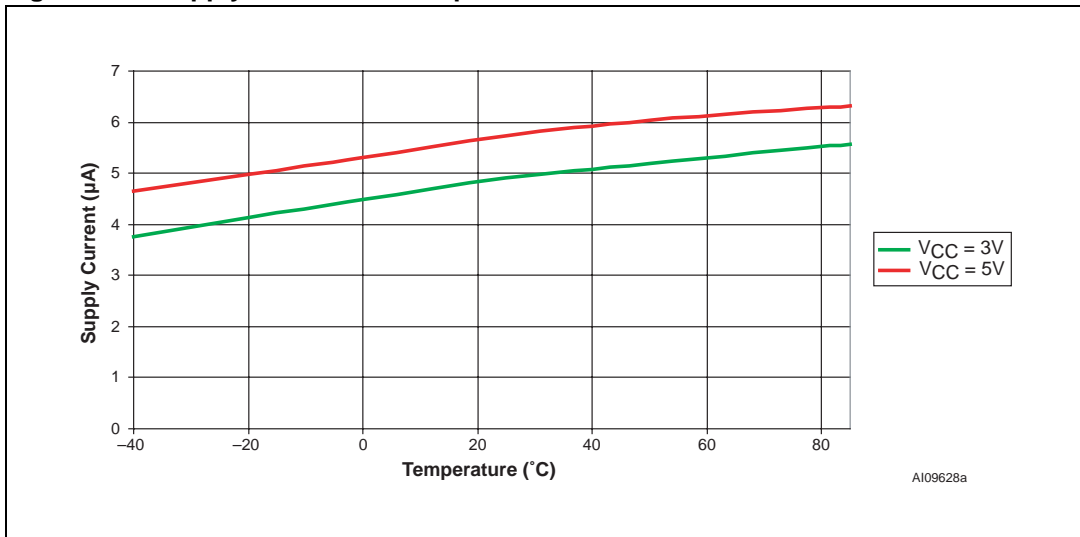

Figure 18. \overline{MR} -to-Reset Output Delay vs. Temperature

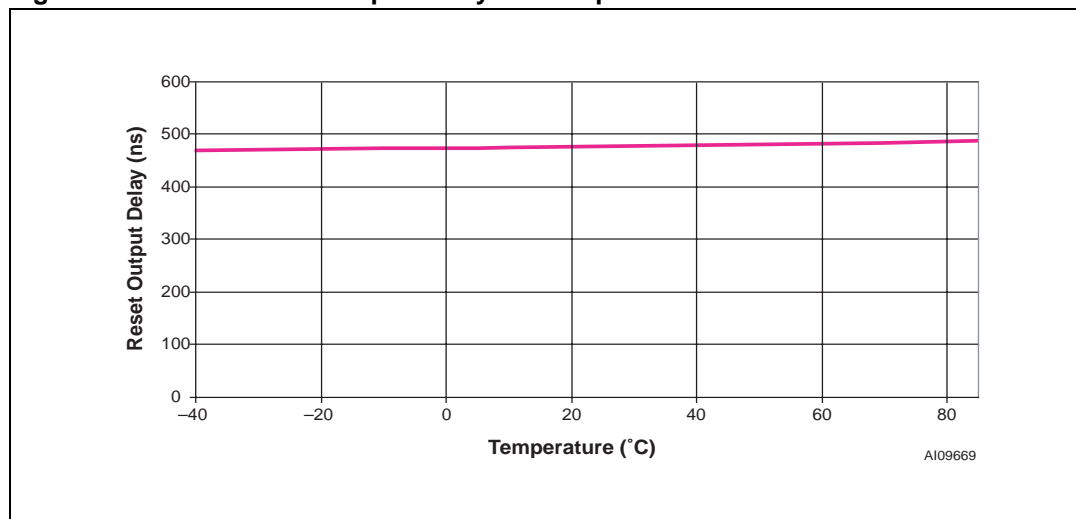

Figure 19. Normalized Power-up t_{rec} vs. Temperature

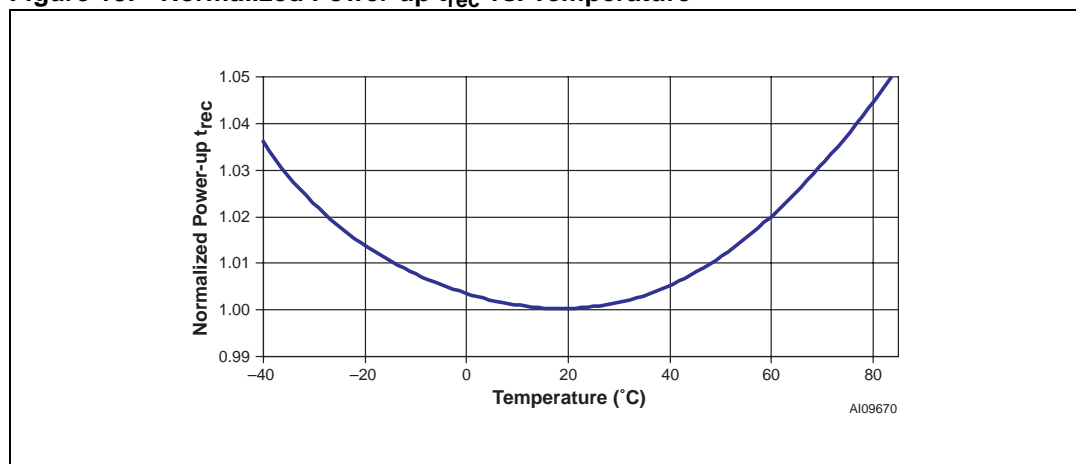

Figure 20. Normalized Reset Threshold Voltage vs. Temperature

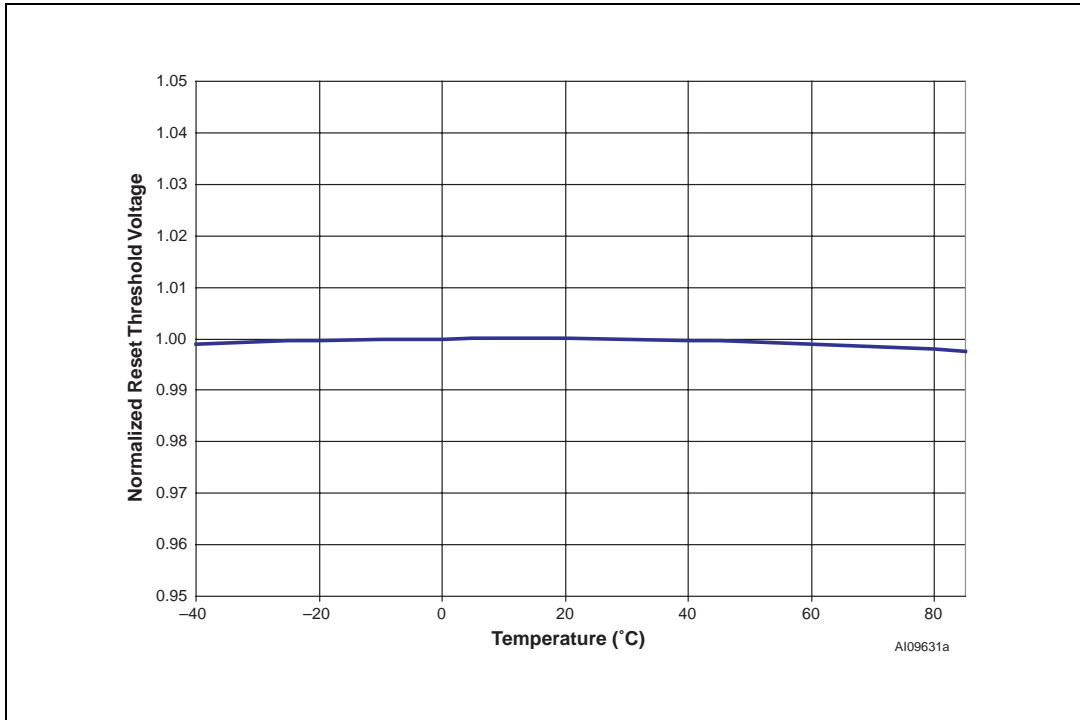

Figure 21. Normalized Power-up Watchdog Time-Out Period

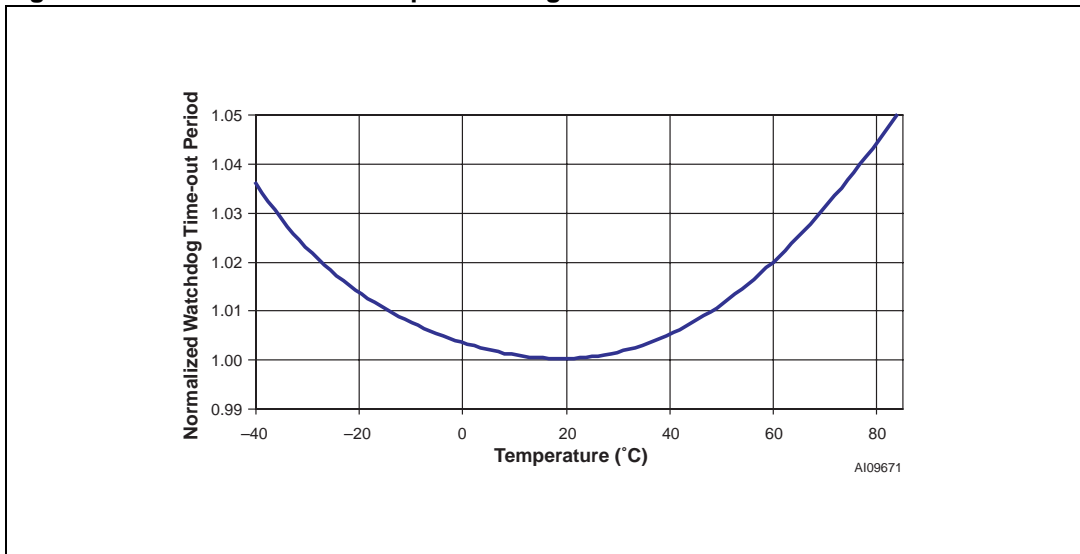

Figure 22. Voltage Output Low vs. I_{SINK}

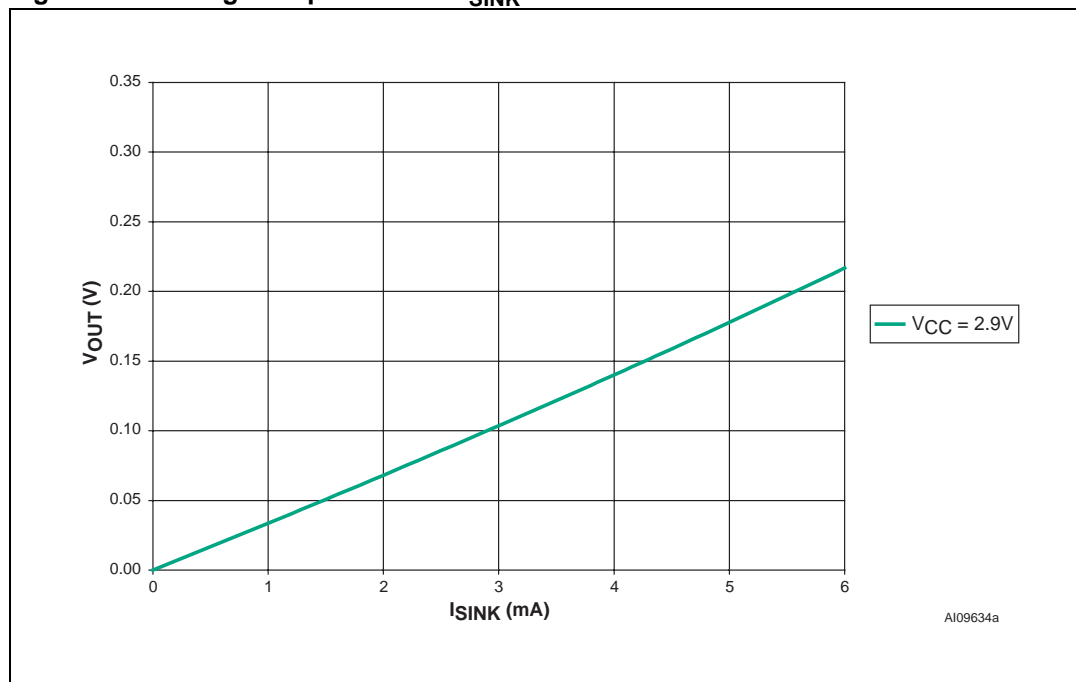

Figure 23. Voltage Output High vs. I_{SOURCE}

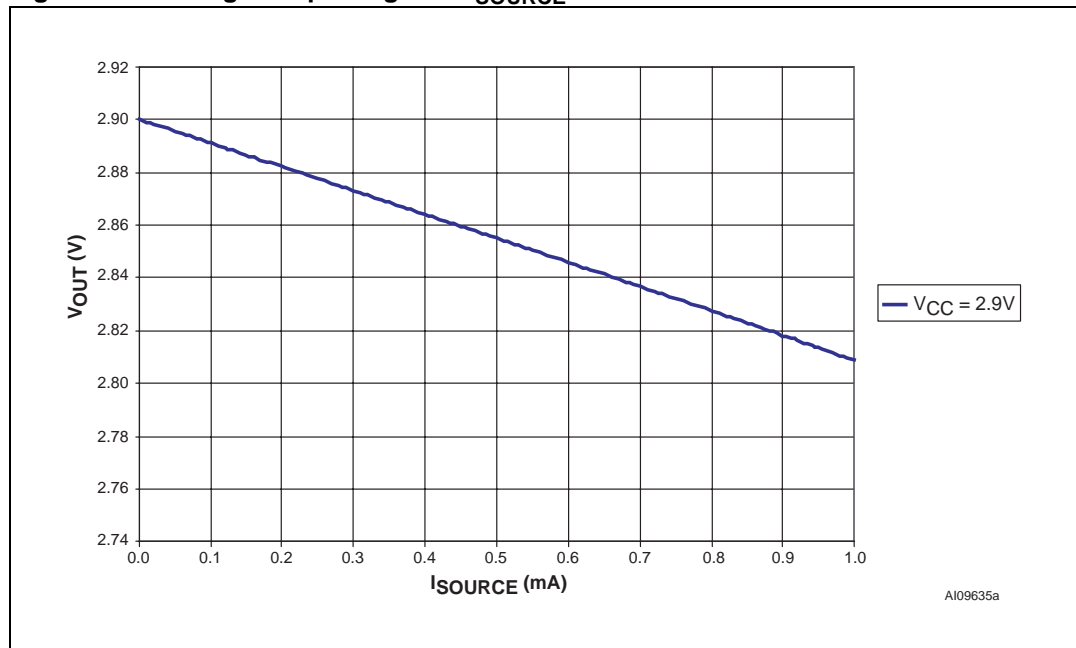
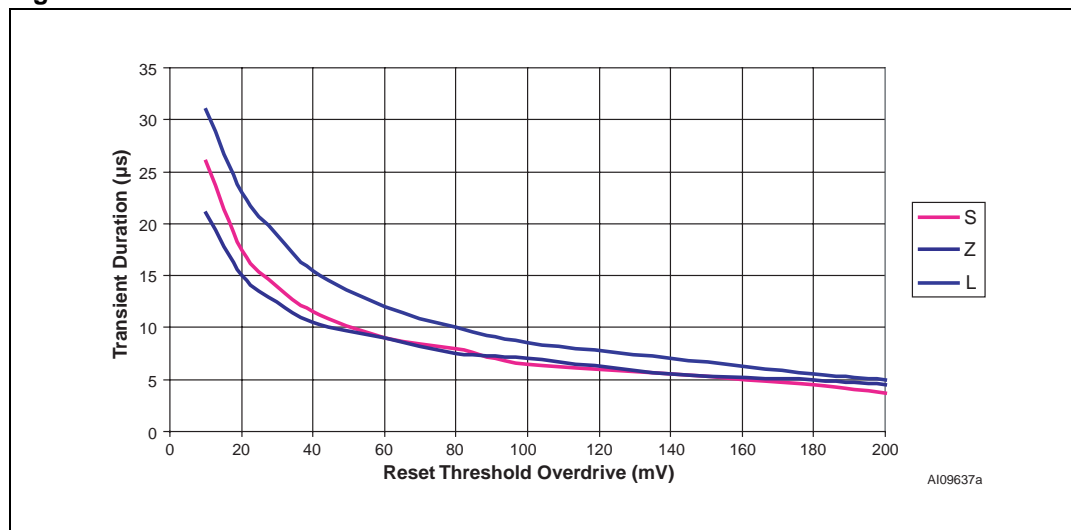

Figure 24. Maximum Transient Duration vs. Reset Threshold Overdrive



4 Maximum Rating

Stressing the device above the rating listed in the [Table 4](#) may cause permanent damage to the device. These are stress ratings only and operation of the device at these or any other conditions above those indicated in the Operating sections of this specification is not implied. Exposure to Absolute Maximum Rating conditions for extended periods may affect device reliability. Refer also to the STMicroelectronics SURE Program and other relevant quality documents.

Table 4. Absolute Maximum Ratings

Symbol	Parameter	Value	Unit
T_{STG}	Storage Temperature (V_{CC} Off)	-55 to 150	°C
$T_{SLD}^{(1)}$	Lead Solder Temperature for 10 seconds	260	°C
V_{IO}	Input or Output Voltage	-0.3 to $V_{CC} + 0.3$	V
V_{CC}	Supply Voltage	-0.3 to 7.0	V
I_O	Output Current	20	mA
P_D	Power Dissipation	320	mW

1. Reflow at peak temperature of 260°C (total thermal budget not to exceed 245°C for greater than 30 seconds).

5 DC and AC Parameters

This section summarizes the operating measurement conditions, and the DC and AC characteristics of the device. The parameters in the DC and AC characteristics Tables that follow, are derived from tests performed under the Measurement Conditions summarized in [Table 5](#). Designers should check that the operating conditions in their circuit match the operating conditions when relying on the quoted parameters.

Table 5. Operating and AC Measurement Conditions

Parameter	STM6xxx	Unit
V _{CC} Supply Voltage	1.0 to 5.5	V
Ambient Operating Temperature (T _A)	-40 to 85	°C
Input Rise and Fall Times	≤5	ns
Input Pulse Voltages	0.2 to 0.8V _{CC}	V
Input and Output Timing Ref. Voltages	0.3 to 0.7V _{CC}	V

Figure 25. AC Testing Input/Output Waveforms

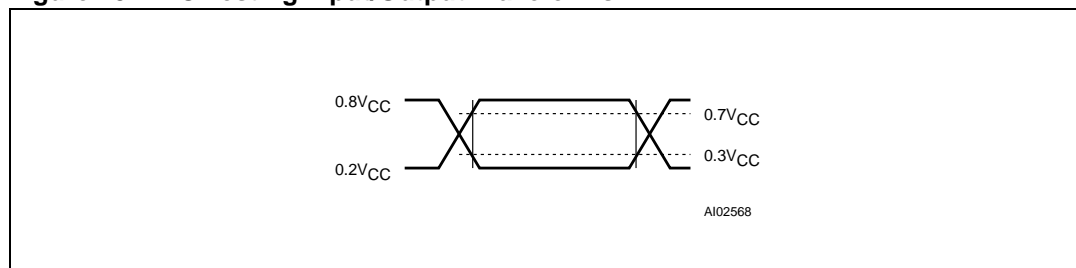
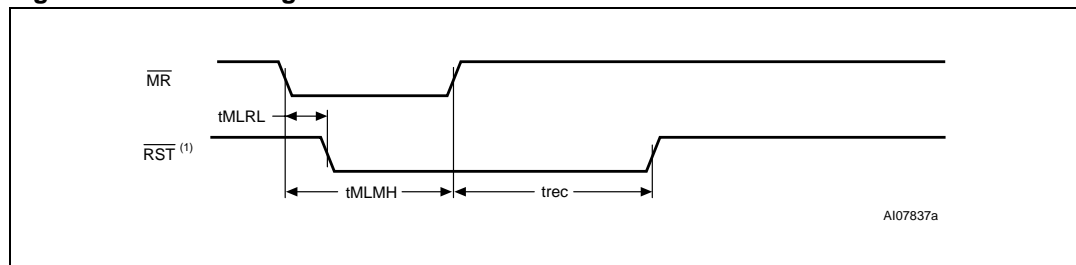

Figure 26. MR Timing Waveform



1. RST for STM6322/6821/6825.

Figure 27. Watchdog Timing

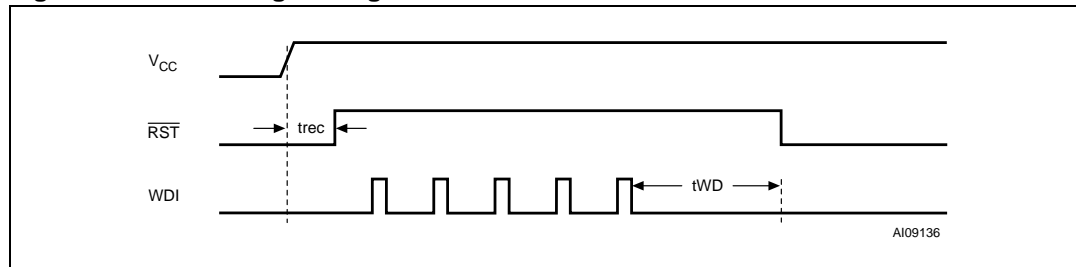

Table 6. DC and AC Characteristics

Sym	Alternative	Description	Test Condition (1)	Min	Typ	Max	Unit
V _{CC}		Operating Voltage		1.2 (2)		5.5	V
I _{CC}		V _{CC} Supply Current ($\overline{\text{MR}}$ and WDI unconnected)	T/S/R/Z (V _{CC} < 3.6V)		4	12	μA
			L/M (V _{CC} < 5.5V)		6	17	μA
		V _{CC} Supply Current ($\overline{\text{MR}}$ unconnected; STM6322/6825)	T/S/R/Z (V _{CC} < 3.6V)		3	8	μA
			L/M (V _{CC} < 5.5V)		3	12	μA
I _{LI}		Input Leakage Current	0V = V _{IN} = V _{CC}	-1		+1	μA
		Input Leakage Current (WDI) ⁽³⁾	WDI = V _{CC} , time average		120	160	μA
			WDI = GND, time average		-20	-15	μA
I _{LO}		Open Drain Reset Output Leakage Current	V _{CC} > V _{RST} , Reset not asserted	-1		+1	μA
V _{IH}		Input High Voltage ($\overline{\text{MR}}$)	V _{RST} > 4.0V	2.0			V
			V _{RST} < 4.0V	0.7V _{CC}			V
V _{IH}		Input High Voltage (WDI) ⁽⁴⁾	V _{RST} (max) < V _{CC} < 5.5V	0.7V _{CC}			V
V _{IL}		Input Low Voltage ($\overline{\text{MR}}$)	V _{RST} > 4.0V			0.8	V
			V _{RST} < 4.0V			0.3V _{CC}	V
V _{IL}		Input Low Voltage (WDI) ⁽⁴⁾	V _{RST} (max) < V _{CC} < 5.5V			0.3V _{CC}	V
V _{OL}		Output Low Voltage ($\overline{\text{RST}}$; Push-pull or Open Drain)	V _{CC} ≥ 1.0V, I _{SINK} = 50μA, Reset asserted			0.3	V
			V _{CC} ≥ 1.2V, I _{SINK} = 100μA, Reset asserted			0.3	V
			V _{CC} ≥ 2.7V, I _{SINK} = 1.2mA, Reset asserted			0.3	V
			V _{CC} ≥ 4.5V, I _{SINK} = 3.2mA, Reset asserted			0.4	V
		Output Low Voltage (RST; Push-pull Only)	V _{CC} ≥ 2.7V, I _{SINK} = 1.2mA, Reset not asserted			0.3	V
			V _{CC} ≥ 4.5V, I _{SINK} = 3.2mA, Reset not asserted			0.4	V
V _{OH}		Output High Voltage ($\overline{\text{RST}}$)	V _{CC} ≥ 2.7V, I _{SOURCE} = 500μA, Reset not asserted	0.8V _{CC}			V
			V _{CC} ≥ 4.5V, I _{SOURCE} = 800μA, Reset not asserted	0.8V _{CC}			V
		Output High Voltage (RST)	V _{CC} ≥ 1.0V, I _{SOURCE} = 1μA, Reset asserted (0°C to 85°C)	0.8V _{CC}			V
			V _{CC} ≥ 1.5V, I _{SOURCE} = 100μA, Reset asserted	0.8V _{CC}			V
			V _{CC} ≥ 2.55V, I _{SOURCE} = 500μA, Reset asserted	0.8V _{CC}			V
		V _{CC} ≥ 4.25V, I _{SOURCE} = 800μA, Reset asserted	0.8V _{CC}			V	

Sym	Alternative	Description	Test Condition (1)	Min	Typ	Max	Unit	
Reset Thresholds								
V _{RST} ⁽⁵⁾		Reset Threshold	STM6xxxL	25°C	4.561	4.630	4.699	V
				-40 to 85°C	4.514		4.746	V
			STM6xxxM	25°C	4.314	4.390	4.446	V
				-40 to 85°C	4.270		4.490	V
			STM6xxxT	25°C	3.040	3.080	3.110	V
				-40 to 85°C	3.000		3.150	V
			STM6xxxS	25°C	2.890	2.930	2.960	V
				-40 to 85°C	2.857		3.000	V
			STM6xxxR	25°C	2.590	2.630	2.660	V
				-40 to 85°C	2.564		2.696	V
			STM6xxxZ ⁽⁶⁾	25°C	2.280	2.320	2.350	V
				-40 to 85°C	2.250		2.380	V
		Reset Threshold Hysteresis	L/M versions			10	mV	
			T/S/R/Z versions			5	mV	
		V _{CC} to $\overline{\text{RST}}$ Delay (V _{RST} - V _{CC} = 100mV, V _{CC} falling at 1mV/μs)			20		μs	
t _{rec} ⁽⁷⁾		Reset Pulse Width	A	1	1.4	2	ms	
			Blank	140	200	280	ms	
			J	240	280	480	ms	
		Reset Threshold Temperature Coefficient			40		ppm/°C	
Push-button Reset Input								
t _{MLMH}	t _{MR}	$\overline{\text{MR}}$ Pulse Width		1			μs	
t _{MLRL}	t _{MRD}	$\overline{\text{MR}}$ to $\overline{\text{RST}}$ Output Delay			500		ns	
		$\overline{\text{MR}}$ Glitch Immunity			100		ns	
		$\overline{\text{MR}}$ Pull-up Resistor		35	52	75	kΩ	
Watchdog Timer								
t _{WD} ⁽⁷⁾		Watchdog Timeout Period		1.12	1.60	2.24	s	
		WDI Pulse Width		50			ns	

- Valid for Ambient Operating Temperature: T_A = -40 to 85°C; V_{CC} = 4.5 to 5.5V for "L/M" versions; V_{CC} = 2.7 to 3.6V for "T/S/R" versions; and V_{CC} = 2.1 to 2.75V for "Z" version (except where noted).
- V_{CC} (min) = 1.0V for TA = 0 to +85°C.
- WDI input is designed to be driven by a three-state output device. To float WDI, the "high-impedance mode" of the output device must have a maximum leakage current of 10μA and a maximum output capacitance of 200pF. The output device must also be able to source and sink at least 200μA when active.
- WDI is internally serviced within the watchdog period if WDI is left unconnected.
- The leakage current measured on the RST pin is tested with the reset asserted (output high impedance).
- Contact local sales office for availability.
- Other t_{rec} and watchdog timings are offered. Minimum order quantities may apply. Contact local sales office for availability.

6 Package Mechanical

Figure 28. SOT23-5 – 5-lead Small Outline Transistor Package Mechanical Drawing

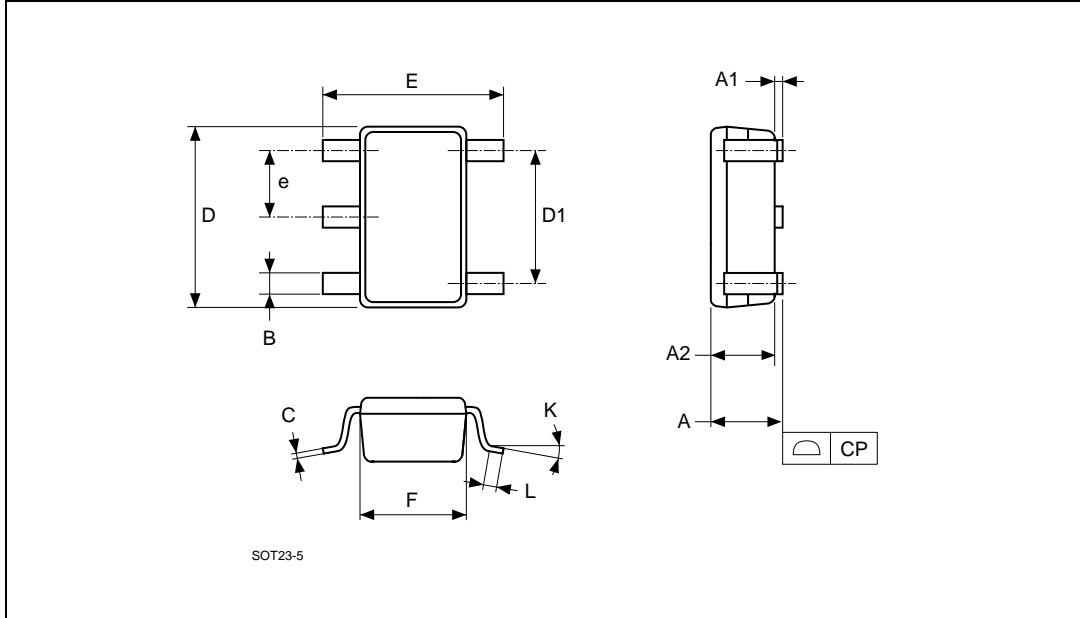

1. Drawing is not to scale.

Table 7. SOT23-5 – 5-lead Small Outline Transistor Package Mechanical Data

Symb	mm			inches		
	Typ	Min	Max	Typ	Min	Max
A	1.200	0.900	1.450	0.0472	0.0354	0.0571
A1			0.150			0.0059
A2	1.050	0.900	1.300	0.0413	0.0354	0.0512
B	0.400	0.350	0.500	0.0157	0.0138	0.0197
C	0.150	0.090	0.200	0.0059	0.0035	0.0079
D	2.900	2.800	3.000	0.1142	0.1102	0.1181
D1	1.900			0.0748		
E	2.800	2.600	3.000	0.1102	0.1024	0.1181
e	0.950			0.0374		
F	1.600	1.500	1.750	0.0630	0.0591	0.0689
K		0	10		0	10
L	0.350	0.100	0.600	0.0138	0.0039	0.0236

7 Part Numbering

Table 8. Ordering Information Scheme

Example:	STM6xxx	L	WY	6	E
Device Type					
STM6xxx					
Reset Threshold Voltage					
L: $V_{RST} = 4.514$ to $4.746V$					
M: $V_{RST} = 4.270$ to $4.490V$					
T: $V_{RST} = 3.000$ to $3.150V$					
S: $V_{RST} = 2.850$ to $3.000V$					
R: $V_{RST} = 2.564$ to $2.696V$					
Z: $V_{RST} = 2.250$ to $2.380V$ ⁽¹⁾					
Reset Pulse Width ⁽²⁾					
A: $t_{rec} = 1$ to $2ms$					
Blank: $t_{rec} = 140$ to $280ms$					
J: $t_{rec} = 240$ to $480ms$					
Package					
WY = SOT23-5					
Temperature Range					
6 = -40 to $85^{\circ}C$					
Shipping Method					
E = ECOPACK Package, Tubes					
F = ECOPACK Package, Tape & Reel					

1. Contact local sales office for availability.
2. Contact local sales office for availability. Other t_{rec} and watchdog timings are offered. Minimum order quantities may apply. Contact local sales office for availability.

For other options, or for more information on any aspect of this device, please contact the ST Sales Office nearest you.

Table 9. Marking Description

Part Number	Reset Threshold (V)	Reset Pulse Width (ms)	Topside Marking
STM6321MAWY6F	4.390	1.4	5CRx
STM6321LWY6F	4.630	200	5AUx
STM6321MWY6F	4.390	200	5AVx
STM6321TWY6F	3.080	200	5AWx
STM6321SWY6F	2.930	200	5AXx
STM6321RWY6F	2.630	200	5AYx
STM6322LWY6F	4.630	200	5BAx
STM6322MWY6F	4.390	200	5BBx
STM6322TWY6F	3.080	200	5BCx
STM6322SWY6F	2.930	200	5BDx
STM6322RWY6F	2.630	200	5BEx
STM6821LWY6F	4.630	200	5BGx
STM6821MWY6F	4.390	200	5BHx
STM6821TWY6F	3.080	200	5BJx
STM6821SWY6F	2.930	200	5BKx
STM6821RWY6F	2.630	200	5BLx
STM6822LWY6F	4.630	200	5BNx
STM6822MWY6F	4.390	200	5BPx
STM6822TWY6F	3.080	200	5BQx
STM6822SWY6F	2.930	200	5BRx
STM6822RWY6F	2.630	200	5BSx
STM6823LWY6F	4.630	200	5BUx
STM6823MWY6F	4.390	200	5BVx
STM6823TWY6F	3.080	200	5BWx
STM6823SWY6F	2.930	200	5BXx
STM6823RWY6F	2.630	200	5BYx
STM6824LWY6F	4.630	200	5CAx
STM6824MWY6F	4.390	200	5CBx
STM6824TWY6F	3.080	200	5CCx
STM6824SWY6F	2.930	200	5CDx
STM6824RWY6F	2.630	200	5CEx
STM6825LWY6F	4.630	200	5CGx
STM6825MWY6F	4.390	200	5CHx
STM6825TWY6F	3.080	200	5CJx
STM6825SWY6F	2.930	200	5CKx
STM6825RWY6F	2.630	200	5CLx
STM6823TJWY6F	3.080	280	5CQx
STM6823SJWY6F	2.930	280	5CRx
STM6823RJWY6F	2.630	280	5CSx

Note: Where "x" = Assembly Work Week (A to Z), such that "A" = WW01-02, "B" = WW03-04, and so forth.

8 Revision History

Table 10. Document Revision History

Date	Revision	Changes
August 25, 2004	1.0	First Draft
15-Dec-04	2.0	Update characteristics (Figure 16 , 17 , 18 ; Table 6 , and 8)
10-Mar-05	3.0	Document promoted to Datasheet status
17-Jun-05	4.0	Package marking update (Table 9)
11-Apr-06	5	Update characteristics, Lead-free text, availability (Figure 4 , 5 , 6 , 7 , 8 , 9 , and 10 ; Table 1 , 6 , 8 , and 9)
11-Aug-2006	6	Update Summary Description , Table 8 , and 9 .

Please Read Carefully:

Information in this document is provided solely in connection with ST products. STMicroelectronics NV and its subsidiaries ("ST") reserve the right to make changes, corrections, modifications or improvements, to this document, and the products and services described herein at any time, without notice.

All ST products are sold pursuant to ST's terms and conditions of sale.

Purchasers are solely responsible for the choice, selection and use of the ST products and services described herein, and ST assumes no liability whatsoever relating to the choice, selection or use of the ST products and services described herein.

No license, express or implied, by estoppel or otherwise, to any intellectual property rights is granted under this document. If any part of this document refers to any third party products or services it shall not be deemed a license grant by ST for the use of such third party products or services, or any intellectual property contained therein or considered as a warranty covering the use in any manner whatsoever of such third party products or services or any intellectual property contained therein.

UNLESS OTHERWISE SET FORTH IN ST'S TERMS AND CONDITIONS OF SALE ST DISCLAIMS ANY EXPRESS OR IMPLIED WARRANTY WITH RESPECT TO THE USE AND/OR SALE OF ST PRODUCTS INCLUDING WITHOUT LIMITATION IMPLIED WARRANTIES OF MERCHANTABILITY, FITNESS FOR A PARTICULAR PURPOSE (AND THEIR EQUIVALENTS UNDER THE LAWS OF ANY JURISDICTION), OR INFRINGEMENT OF ANY PATENT, COPYRIGHT OR OTHER INTELLECTUAL PROPERTY RIGHT.

UNLESS EXPRESSLY APPROVED IN WRITING BY AN AUTHORIZED ST REPRESENTATIVE, ST PRODUCTS ARE NOT RECOMMENDED, AUTHORIZED OR WARRANTED FOR USE IN MILITARY, AIR CRAFT, SPACE, LIFE SAVING, OR LIFE SUSTAINING APPLICATIONS, NOR IN PRODUCTS OR SYSTEMS WHERE FAILURE OR MALFUNCTION MAY RESULT IN PERSONAL INJURY, DEATH, OR SEVERE PROPERTY OR ENVIRONMENTAL DAMAGE. ST PRODUCTS WHICH ARE NOT SPECIFIED AS "AUTOMOTIVE GRADE" MAY ONLY BE USED IN AUTOMOTIVE APPLICATIONS AT USER'S OWN RISK.

Resale of ST products with provisions different from the statements and/or technical features set forth in this document shall immediately void any warranty granted by ST for the ST product or service described herein and shall not create or extend in any manner whatsoever, any liability of ST.

ST and the ST logo are trademarks or registered trademarks of ST in various countries.

Information in this document supersedes and replaces all information previously supplied.

The ST logo is a registered trademark of STMicroelectronics. All other names are the property of their respective owners.

© 2006 STMicroelectronics - All rights reserved

STMicroelectronics group of companies

Australia - Belgium - Brazil - Canada - China - Czech Republic - Finland - France - Germany - Hong Kong - India - Israel - Italy - Japan - Malaysia - Malta - Morocco - Singapore - Spain - Sweden - Switzerland - United Kingdom - United States of America

www.st.com