



life.augmented

Releasing your creativity

STM32F0 series

Mainstream 32-bit MCUs



- F0 inside STM32 Family 3
- 9 product series - 32 product lines 3
- STM32 F0 Entry-level MCU 4
- STM32F0 product lines 4
- STM32F0x0 Value line 5
- STM32F0 Value line portfolio 5
- STM32F030 block diagram 5
- STM32F0x1 line 6
- STM32F0x1 portfolio 6
- STM32F091 block diagram 6
- STM32F0x2 line 7
- STM32F0x2 portfolio 7
- STM32F072 block diagram 7
- STM32F0x8 line 8
- STM32F0x8 portfolio 8
- 1.8 V STM32 bridges mobile platform subsystems 8
- STM32F0 Ecosystem 9
- STM32 Nucleo expansion boards 10
- Achieving SIL2/3 with STM32F0 10



By choosing one of ST's microcontrollers for your embedded application, you gain from our leading expertise in MCU architecture, technology, multi-source manufacturing and long term supply.

The STM32 portfolio offers an extraordinary variety of options, now including ARM® Cortex®-M cores (M0, M0+, M3, M4 and M7), giving developers flexibility to find the perfect STM32 for their applications. Particular attention is paid to accommodate porting of applications from one device to another. The binary compatibility combined with the similar pinout assignment, hardware IPs proliferation and higher level programming language makes the development job far more convenient when dealing with the STM32 families.

9 PRODUCT SERIES - 32 PRODUCT LINES

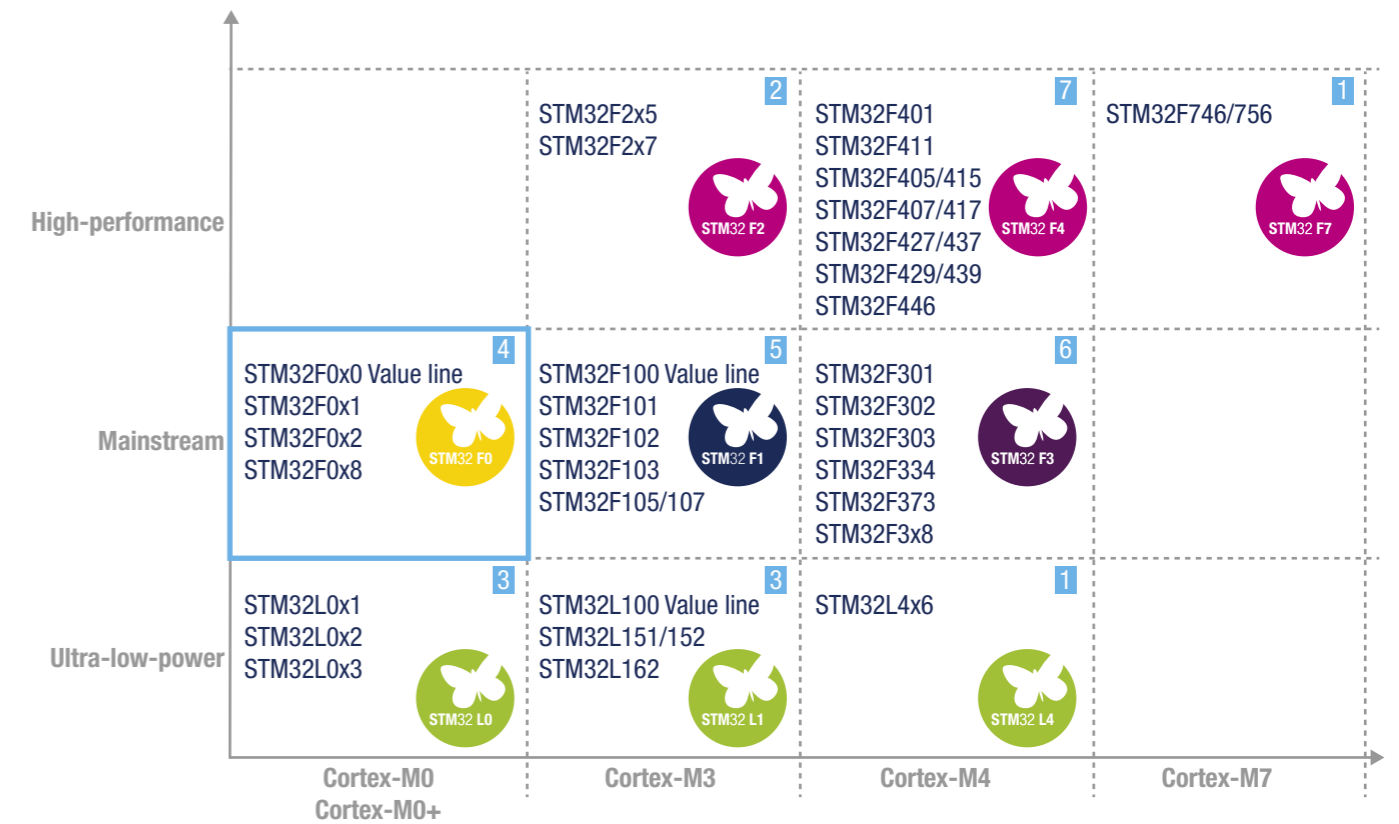

■ Number of lines

The Mainstream family addresses a large variety of needs found in general-purpose applications, while the STM32 portfolio offers the possibility to boost performance with more MIPS or improve ultra-low power values. The STM32F0 series is the entry level of the three series of the Mainstream family, where price effectiveness and simplicity are primary requirements. The pin compatibility with STM32F1 or STM32F3 series makes navigation across the board extremely convenient.



The STM32F0 series with a Cortex®-M0 core addresses cost-sensitive designs originally served by 8- or 16-bit microcontrollers. The "STM32 at 32 cents" offer is a clear illustration of this capability.

STM32 F0 Entry-level MCU

The STM32F0 series is well balanced for efficiency

Devices in ST's ARM Cortex-M0-based STM32F0 series deliver 32-bit performance while featuring the essentials of the STM32 family and are particularly suited for cost-sensitive applications. STM32F0 MCUs combine real-time performance, low-power operation, and the advanced architecture and peripherals of the STM32 platform.

- The STM32F0x0 Value line is highly competitive in traditional 8-bit and 16-bit markets
- The STM32F0x1 line provides a high integration of functions and covers a wide range of memory sizes and packages
- The STM32F0x2 line provides rich connectivity with a crystal-less USB 2.0 interface
- The STM32F0x8 line operating at 1.8V ± 8% is well suited for use in portable consumer applications



STM32F0 PRODUCT LINES

- Cortex-M0 – 48 MHz**
- Reset POR/PDR
 - 2x watchdogs
 - Hardware CRC
 - Internal RC
 - Crystal oscillators
 - PLL
 - RTC calendar
 - 16- and 32-bit timers
 - 1x12-bit ADC
 - Temperature sensor
 - Multiple channel DMA
 - Single wire debug
 - Unique ID

| Product line | FLASH (KB) | RAM (KB) | Power supply | 20-byte backup data | 12-bit DAC Comp. | Touch sense | Up to 2xSPI/ I ² S, 2xI ² C | USART | CEC | CAN | USB |
|-----------------------------------|------------|----------|--------------|---------------------|---------------------|-------------|---|-------|-----|-----|------------------|
| STM32F0x0 Value line | 16 to 256 | 4 to 32 | 2.4 to 3.6 V | | | | • | 6 | | | • |
| STM32F0x1 Access line | 16 to 256 | 4 to 32 | 2.0 to 3.6 V | • | • | • | • | 8 | • | • | |
| STM32F0x2 USB line | 16 to 128 | 4 to 16 | 2.0 to 3.6 V | • | • | • | • | 4 | • | • | • (crystal-less) |
| STM32F0x8 Low voltage line | 32 to 256 | 4 to 32 | 1.8 V +/- 8% | • | • | • | • | 8 | • | | • (crystal-less) |

www.st.com/stm32f0

The same system block is common within the STM32F0 family. Migration across the lines is facilitated as the same peripherals, IP-set and pinouts are shared.

By construction, the parameters are guaranteed over all voltage ranges, eliminating performance degradation due to unstable supply voltages.

With very flexible power consumption settings, developers can adjust the working modes on the fly, ensuring a fine control of the device.

TYPICAL CONSUMPTION VALUES ACROSS STM32F0 POWER MODES

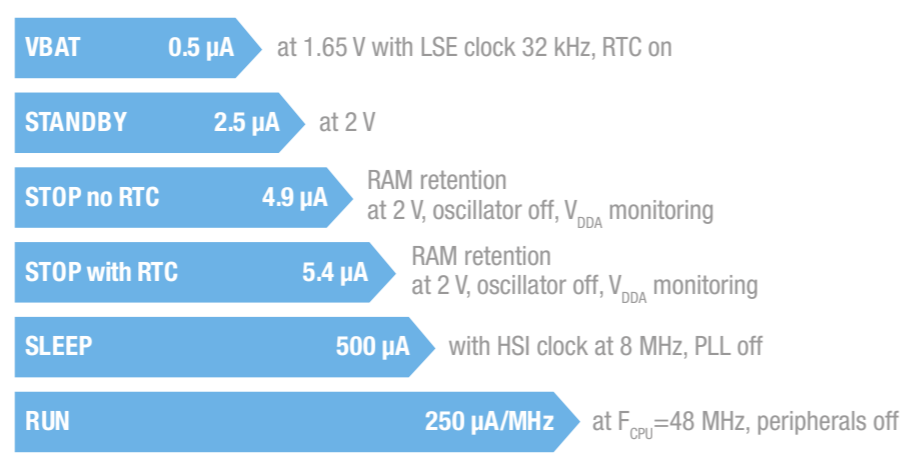

STM32F0x0 Value line

The STM32F0x0 features an ARM Cortex-M0 core and runs at speeds up to 48 MHz

The STM32F0x0 Value line covers the main needs for memory and pin count combinations with fewer devices to increase focus on the overall cost efficiency of your projects. Application designers starting with the STM32F0x0 benefit from being able to upgrade to any of the devices in the powerful STM32 portfolio at any time with an extraordinary degree of reusability of tools and application software.

STM32F0 VALUE LINE PORTFOLIO

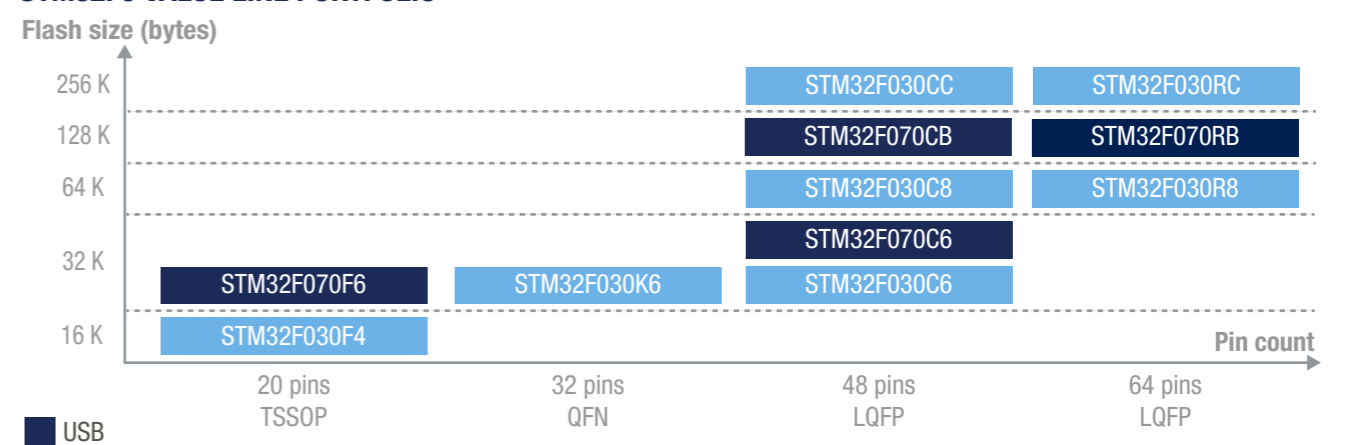

Economy of scales realized by reducing the quantity of variances directly benefit our customers.

Respecting the most stringent quality requirements, the Value line is produced in high volume, making the supply chain and inventory management less costly for our customers.

STM32F030 BLOCK DIAGRAM

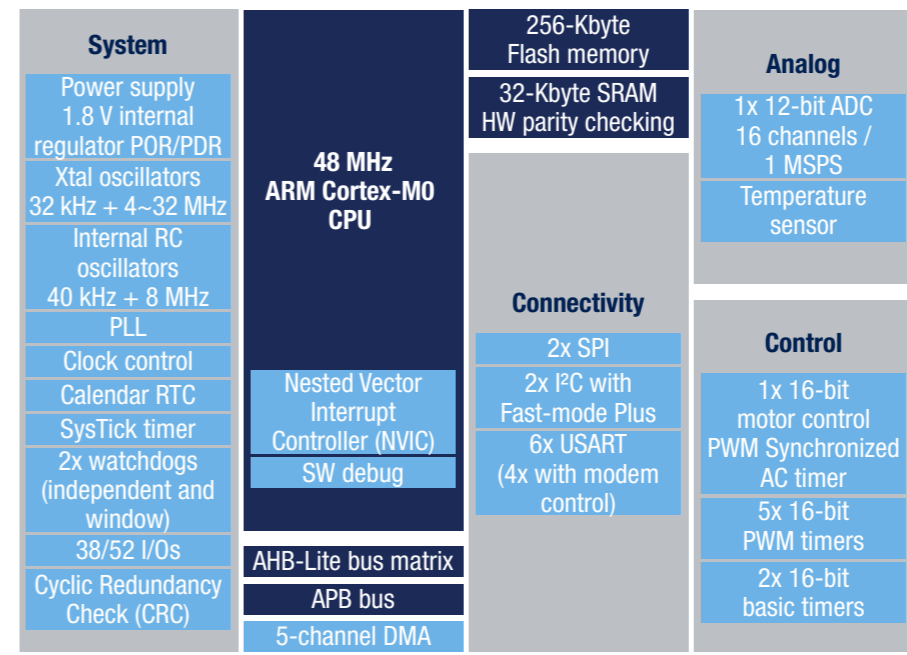

The system block is very similar to other STM32F0 lines, making the extension for additional voltage range or functionality more convenient.

Upward compatibility with STM32F0x1 and F0x2 devices is guaranteed from a hardware and software viewpoint.



STM32F0x1 offers better user experience with high integration

STM32F0x1 devices are intended to address 8- and 16-bit applications where satisfactory performance is required, for example in home-entertainment products, appliances and industrial equipment. The portfolio covers from 16 to 256 Kbytes of on-chip Flash memory, up to 32 Kbytes of SRAM, and several communication interfaces including USART, SPI, I²S, I²C, CAN, HDMI CEC and 16-bit PWM standard or motor control dedicated timers.

The latest addition to ST's STM32F0x1 series, the STM32F091, comes with up to eight USARTs. Its 256 Kbytes of on-chip Flash memory and 32 Kbytes of SRAM enable the implementation of high level languages such as a Java stack.

STM32F0x1 PORTFOLIO

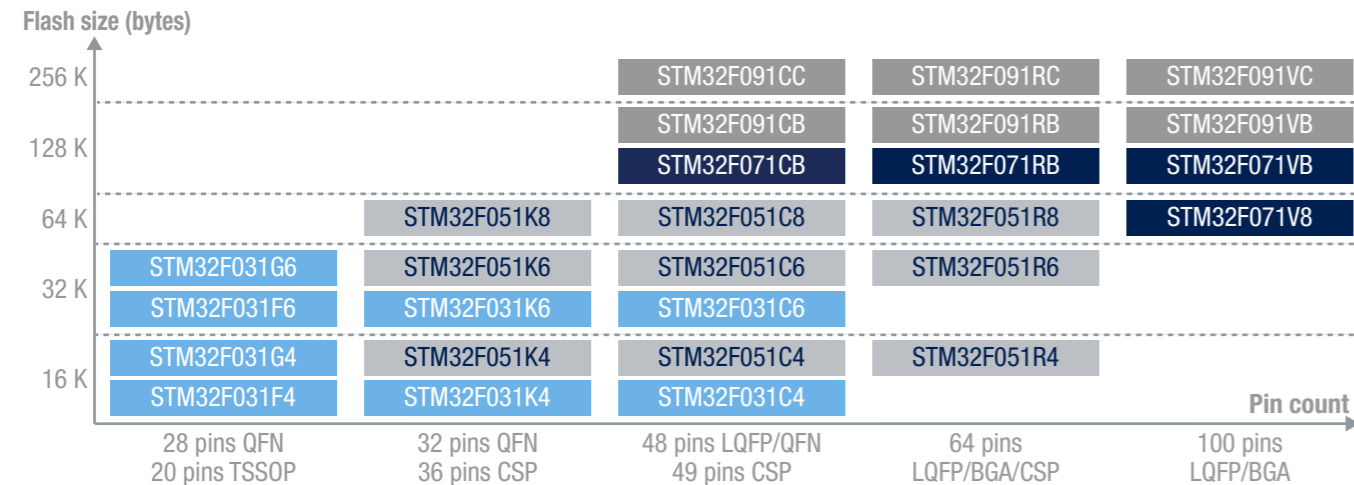

Flexible hardware selection with a 48-pin package covering from 256 Kbytes all the way down to 16 Kbytes of program memory.

STM32F091 BLOCK DIAGRAM

| System | 48 MHz ARM Cortex-M0 CPU | 256-Kbyte Flash memory | Analog |
|---|---|--|------------------------------------|
| Power supply 1.8 V internal regulator POR/PDR/PVD | Nested Vector Interrupt Controller (NVIC) SW debug | 32-Kbyte SRAM HW parity checking | 1x 12-bit DAC 2-channel |
| Xtal oscillators 32 kHz + 4~32 MHz | | 20-byte backup data | 1x 12-bit ADC 16 channels / 1 MSPS |
| Internal RC oscillators 40 kHz + 8 MHz | | Connectivity | 2x analog comparator |
| Internal RC oscillator 48 MHz (auto trimming on ext. synchro) PLL | | | HDMI CEC |
| Clock control | 2x SPI (with I ² S mode) | | Control |
| Calendar RTC | 2x I ² C with Fast-mode Plus | 1x 16-bit motor control PWM Synchronized AC timer | |
| SysTick timer | 1x CAN | 1x 32-bit timers | |
| 2x watchdogs (independent and window) | AHB-Lite bus matrix | 8x USART (4x with modem control, 3x with LIN, smartcard, IrDA) | 5x 16-bit PWM timers |
| 38/52/88 I/Os | APB bus | | 2x 16-bit basic timers |
| Cyclic Redundancy Check (CRC) | 12-channel DMA | | |
| | Touch-sensing Up to 24 keys | | |

The STM32F0x1 line gives developers the opportunity to maintain the whole development configuration as the system block remains unchanged.

Adjusting the peripheral selection according to hardware or software needs has never been so easy.



STM32F0x2 crystal-less USB 2.0 FS and CAN interfaces

These new STM32F0 devices are the first 32-bit Cortex-M0 MCUs in the industry offering a crystal-less USB 2.0 FS interface with a link power management (LPM) feature and compliant with battery charger detection (BCD) specification 1.2, thus eliminating the need for an external crystal oscillator to generate the precision clock required by the USB protocol. Together with the support of CAN, USART, I²C, SPI (I²S) and HDMI CEC interfaces, the new STM32F0 devices enable product developers to increase system integration, reduce costs, and exceed the traditional price performance limitations imposed by older, proprietary 8-bit or 16-bit microcontrollers for USB device or controller applications.

The STM32F0x2 series provides from 16 to 128 Kbytes of Flash memory in 20- to 100-pin packages. These popular package styles are the perfect fit for PC or mobile applications and accessories.

STM32F0x2 PORTFOLIO

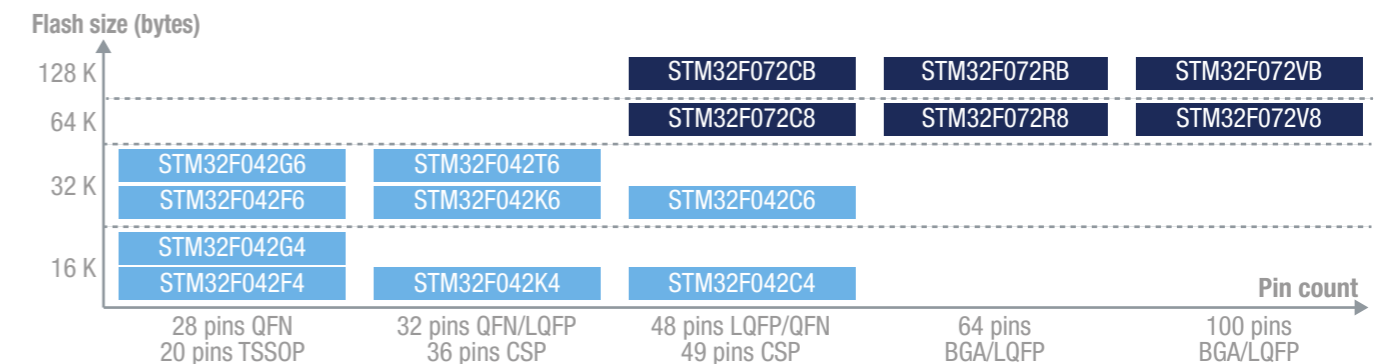

The STM32F0x2 has a built-in USB DFU bootloader.

Designers can program blank STM32F0x2 devices in a newly-assembled board or upgrade the application firmware during development or pre-production via USB without the need of specific programming tools or cables.

STM32F072 BLOCK DIAGRAM

| System | 48 MHz ARM Cortex-M0 CPU | 128-Kbyte Flash memory | Analog |
|---|---|--|------------------------------------|
| Power supply 1.8 V internal regulator POR/PDR/PVD | Nested Vector Interrupt Controller (NVIC) SW debug | 16-Kbyte SRAM HW parity checking | 1x 12-bit DAC 2-channel |
| Xtal oscillators 32 kHz + 4~32 MHz | | 20-byte backup data | 1x 12-bit ADC 16 channels / 1 MSPS |
| Internal RC oscillators 40 kHz + 8 MHz | | Connectivity | 2x analog comparator |
| Internal RC oscillator 48 MHz (auto trimming on ext. synchro) PLL | | | HDMI CEC |
| Clock control | 2x SPI (with I ² S mode) | | Control |
| Calendar RTC | 2x I ² C with Fast-mode Plus | 1x 16-bit motor control PWM Synchronized AC timer | |
| SysTick timer | 1x CAN | 1x 32-bit timers | |
| 2x watchdogs (independent and window) | AHB-Lite bus matrix | 4x USART with modem control (2x with LIN, smartcard, IrDA) | 5x 16-bit PWM timers |
| 37/51/87 I/Os | APB bus | | 2x 16-bit basic timers |
| Cyclic Redundancy Check (CRC) | 12-channel DMA | | |
| | Touch-sensing Up to 24 keys | | |

The combination of the USB Full Speed device interface together with a large variety of analog and digital peripherals make the design more compact and more integrated.

To simplify development for non-USB experts, we provide a free USB Full-Speed Device Library as well as a set of examples and a demo based on various audio, CCID, CDC, HID, VCP, and MSC classes.



The STM32F0x8 low voltage 1.8 V family

The STM32F0x8 line operates at 1.8 V ± 8%. It is well suited for use in portable consumer applications such as smartphones, accessories and media devices, and allows designers to take advantage of the same features as the STM32F0 series with no compromise or degradation in processing performance when operating at lower voltages.

The combination of a 1.8 V digital supply voltage, a separate I/O voltage supply rail and an independent analog domain is an advantage in heterogeneous system architectures, leading to simplified system design and connected cost savings. The STM32F0x8 devices are ideal low-voltage companion microcontrollers, allowing to maintain a wide analog dynamic range or to directly connect USB devices.

STM32F0x8 PORTFOLIO

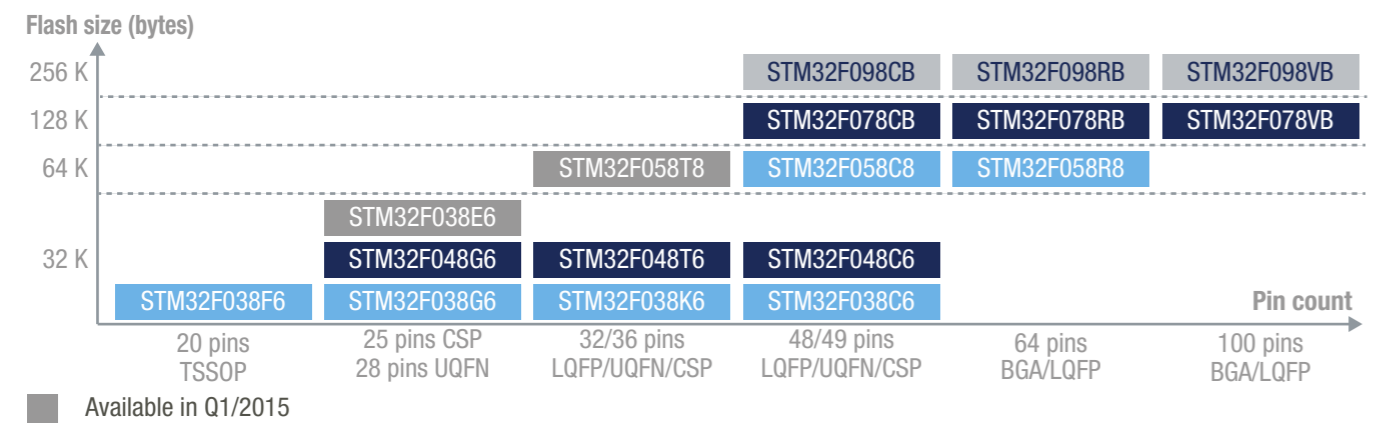

1.8 V STM32 BRIDGES MOBILE PLATFORM SUBSYSTEMS

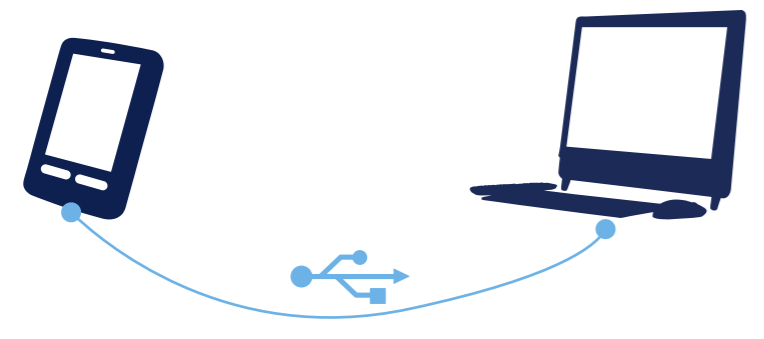

A single device will accept various voltage levels, bridging heterogeneous hardware implementation without the need for voltage level shifters.

1.8V STM32

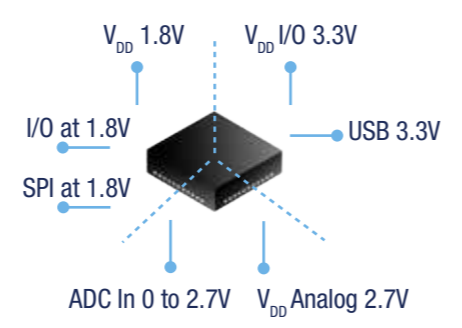

Hardware tools

Various types of development boards let you get started with STM32F0 products.

The STM32 Nucleo boards provide an affordable and flexible way for users to try out new ideas and build prototypes with a wide choice of specialized expansion boards. The Discovery kits let developers quickly explore key features of STM32F0 products, while the evaluation boards highlight all MCU functions. All these development boards include an integrated debugger programmer as well as ready-to-use software examples helping developers to promptly get started.

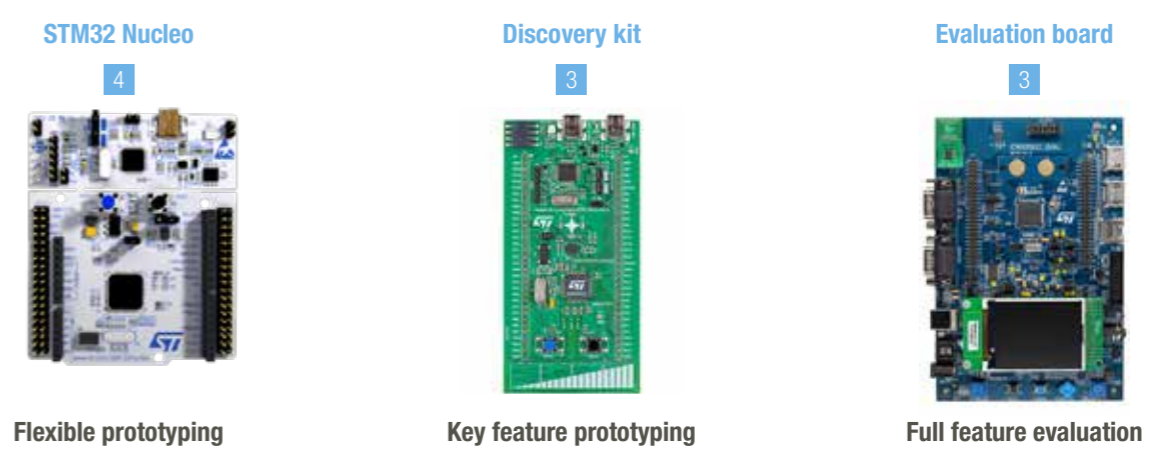

■ Number of hardware tools
www.st.com/stm32evaltools

STM32 NUCLEO

- Open platform with a single STM32 MCU and integrated debugger/programmer.
- At least one board per main series STM32F030, F070/72 and F091.
- 2 types of connectors for unlimited expansion possibilities.
- Support for multiple IDEs and mbed online tools.
- \$10.32 recommended resale price.
www.st.com/stm32nucleo

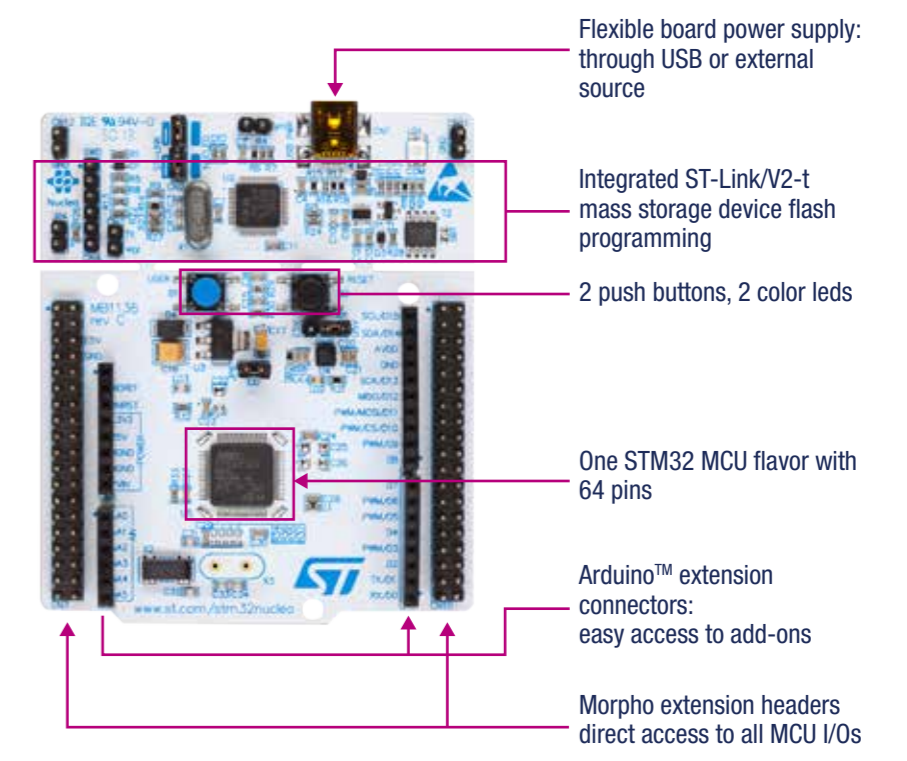

STM32 NUCLEO EXPANSION BOARDS

- Expansion boards allow you to add specialized functions (sense, connectivity...) with companion chips through Arduino™ or Morpho connectors.
- The portability of associated software components let you target several STM32 MCUs.

www.st.com/x-nucleo

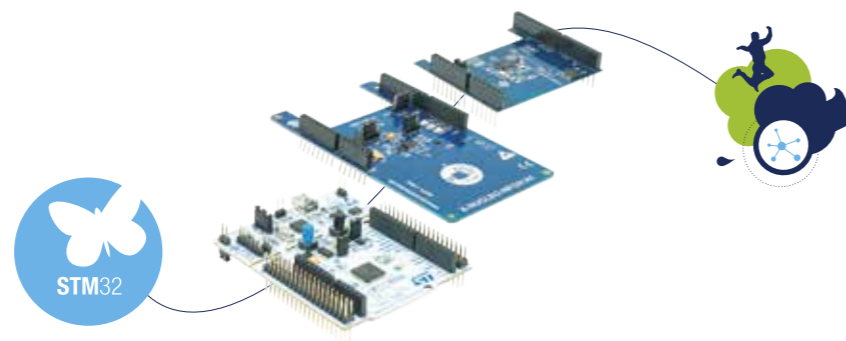

Software development tools offer

ST suggests a 3-step approach for standard development in C: configuration and generation, compile and debug, and then monitoring.

- Configure the microcontroller using the STM32CubeMX tool.
 - Optionally generate code depending on user choices, if STM32CubeF0 embedded software is used.
- Develop the application, compile and debug using integrated development environments (IDEs) from our partners: IAR, ARM/Keil*, Ac6*, Atollic, Altium, **CooCox***, Emprog, Hitex, iSystem, Keolabs/Raisonance, Rowley or Segger.
- Monitor the application while it is running without affecting application behavior (non-intrusive) with STMStudio www.st.com/stmstudio

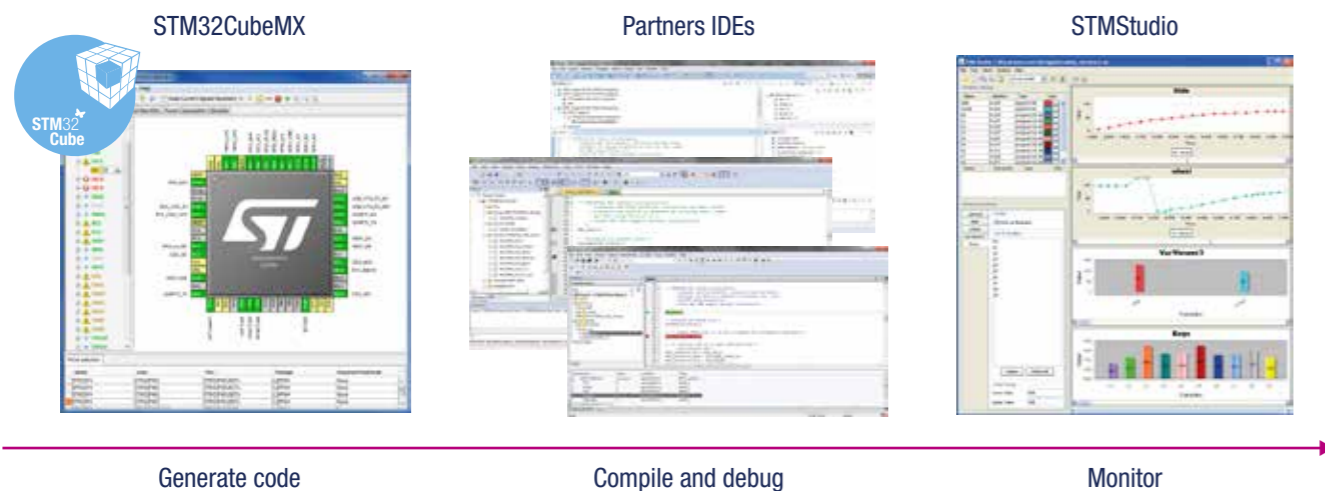

* Free IDE

ACHIEVING SIL2/3 WITH STM32F0

Quickly achieve IEC 61508 Safety Integrity Level (SIL) certification with STM32F0 Functional Safety Package developed in partnership with Yogitech :

- STM32F0 Safety Manual : a user guide including detailed list of safety requirements and examples
- fRSTL_stm32f0 library : a set of ready to use, verified and application independent Software Test Libraries
Visit www.yogitech.com

www.st.com/stm32safety

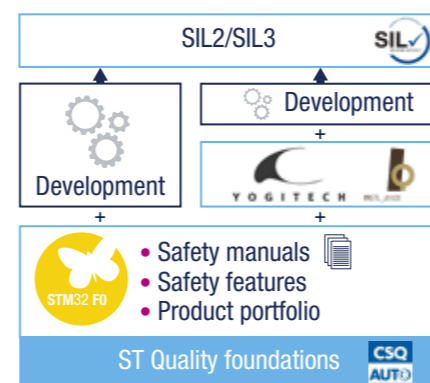

Recommendations for choosing embedded software

When choosing between a strategy for code optimization or portability, here are some recommendations:

- STM32Snippets**: a collection of examples, optimized for direct access to registers
 - Best option for users looking for size and performance optimization.
 - It is also a good choice for 8-bit MCU users wishing to start on a 32-bit MCU, granting access to a level of control very close to hardware, with a very well-fit footprint.
 - STM32Snippets** examples are also included in STM32F0 MCU reference manuals
- Standard Peripheral Library: for portability at the STM32 series level. For instance, easy portability within the STM32F0 series
 - Good tradeoff for users willing to remain within the STM32F0 series.
- STM32Cube** embedded software: for portability at the entire STM32 family level. Easing the reuse of applications from one STM32 MCU to another
 - Correct choice for users who may want to easily port their application to another STM32 MCU
 - Benefits from the full features of the STM32CubeMX tool on the PC, enabling access to code generation based on the user configuration and STM32CubeF0 embedded software
- CMSIS** Driver and mbed abstraction layer: an abstraction layer for any ARM® Cortex®-M based microcontroller
- Solutions outside the microcontroller world**: STM32Java, .Net Micro framework, or Matlab/Simulink

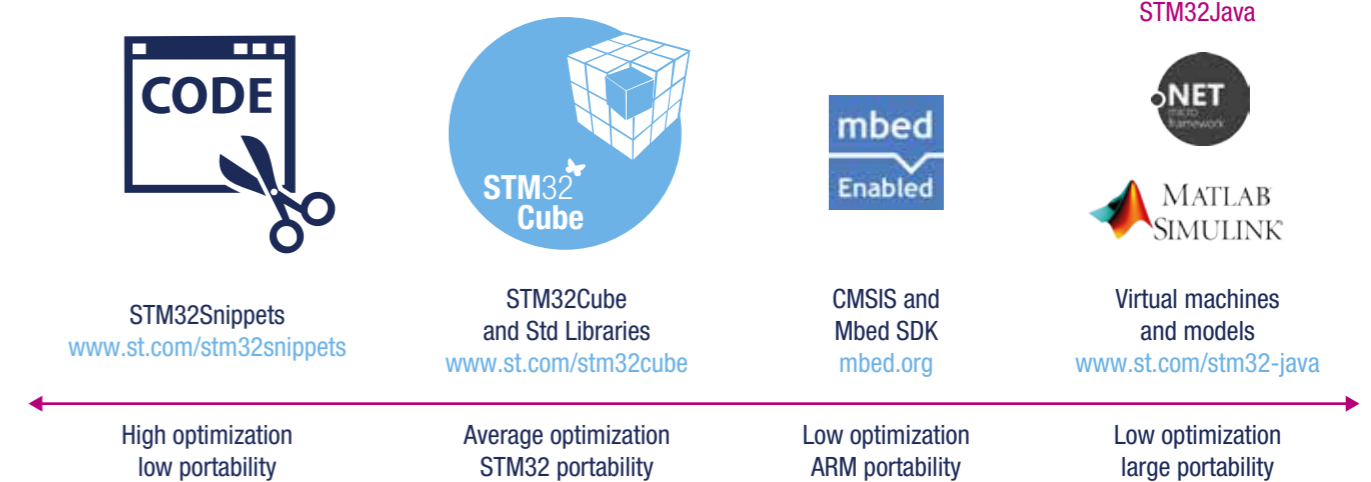

Collaterals

www.st.com is a valuable source of information and support with a documentation repository, forums, video and social media that help provide solutions for any issues or challenges that you may encounter. The existing community around ARM Cortex cores is already big enough that developers will likely find existing solutions or examples ready to be imported.

Please download our mobile version of the ST MCU Finder which makes MCU selection easy. It is available for Apple, Windows and Android mobile platforms.

st.com



ST MCU finder
www.st.com/stmcfinder



Various social media

-  [ST forums on microcontrollers](#)
-  facebook.com/stm32
-  twitter.com/@ST_World
-  youtube.com/STonlineMedia
-  Mbed.org



STM32F0 shortcuts

- www.st.com/stm32f0
- www.st.com/stm32f0x1
- www.st.com/stm32evaltools
- www.st.com/stm32discovery
- www.st.com/stm32nucleo

- www.st.com/stm32embeddedsoftware
- www.st.com/stm32snippets
- www.st.com/stm32cube
- mbed.org
- www.st.com/stm32-java

- www.st.com/stmcfinder
- www.st.com/stmstudio
- www.yogitech.com
- www.st.com/x-nucleo

