



STP120NF10, STB120NF10 STF120NF10, STW120NF10

N-channel 100 V, 0.009 Ω , 110 A STripFET™ II Power MOSFET
in TO-247, TO-220, D²PAK, TO-220FP

Features

Type	V _{DSS}	R _{DS(on) max}	I _D
STW120NF10	100V	<0.0105 Ω	110 A
STP120NF10			110 A
STB120NF10			110 A
STF120NF10			41 A

- Exceptional dv/dt capability
- 100% avalanche tested
- Application oriented characterization

Application

- Switching applications

Description

These devices are N-channel Power MOSFET realized with STMicroelectronics unique STripFET™ process has specifically been designed to minimize the on-resistance. It is therefore suitable as primary switch in advanced high-efficiency, high-frequency isolated DC-DC converters for telecom and computer application. It is also intended for any applications with low gate drive requirements.

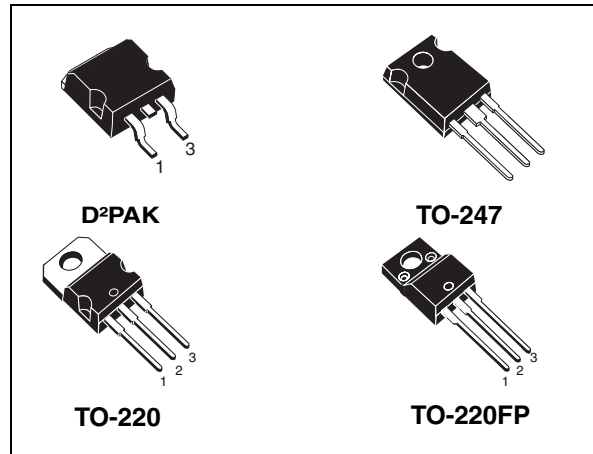

Figure 1. Internal schematic diagram

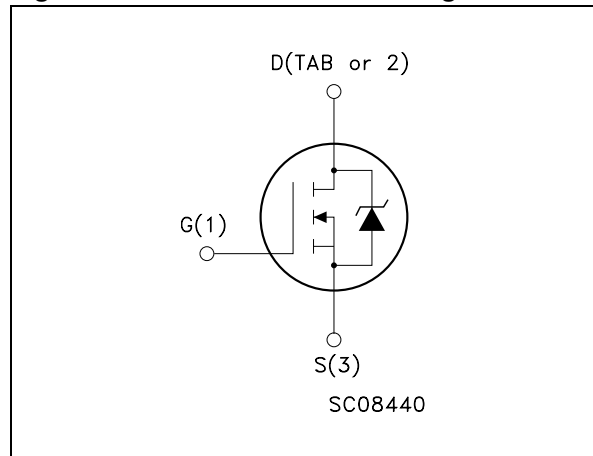

Table 1. Device summary

Order codes	Marking	Packages	Packaging
STB120NF10	B120NF10	D ² PAK	Tape and reel
STF120NF10	120NF10	TO-220FP	Tube
STP120NF10	P120NF10	TO-220	
STW120NF10	W120NF10	TO-247	

Contents

1	Electrical ratings	3
2	Electrical characteristics	4
2.1	Electrical characteristics (curves)	6
3	Test circuits	9
4	Package mechanical data	10
5	Packaging mechanical data	18
6	Revision history	20

1 Electrical ratings

Table 2. Absolute maximum ratings

Symbol	Parameter	Value		Unit
		TO-220, TO-247, D ² PAK	TO-220FP	
V _{DS}	Drain-source voltage (V _{GS} = 0)	100		V
V _{GS}	Gate-source voltage	± 20		V
I _D	Drain current (continuous) at T _C = 25 °C	110	41 ⁽¹⁾	A
I _D	Drain current (continuous) at T _C = 100 °C	77	29 ⁽¹⁾	A
I _{DM} ⁽²⁾	Drain current (pulsed)	440	164 ⁽¹⁾	A
P _{TOT}	Total dissipation at T _C = 25 °C	312	45	W
	Derating factor	2.08	0.30	W/°C
dv/dt ⁽³⁾	Peak diode recovery voltage slope	10		V/ns
E _{AS} ⁽⁴⁾	Single pulse avalanche energy	550		mJ
T _J T _{stg}	Operating junction temperature Storage temperature	-55 to 175		°C

- Limited only by maximum temperature allowed.
- Pulse width limited by safe operating area.
- I_{SD} ≤ 120 A, di/dt ≤ 300 A/μs, V_{DD} = 80%V_{(BR)DSS}
- Starting T_j = 25 °C, I_D = 60 A, V_{DD} = 50 V

Table 3. Thermal resistance

Symbol	Parameter	Value				Unit
		TO-220	TO-247	D ² PAK	TO-220FP	
R _{thj-case}	Thermal resistance junction-case max	0.48			3.33	°C/W
R _{thj-amb}	Thermal resistance junction-ambient max	62.5			62.5	°C/W
R _{thj-pcb} ⁽¹⁾	Thermal resistance junction-pcb max			35		°C/W
T _L	Maximum lead temperature for soldering purpose	300			300	°C

- When mounted on 1inch² FR-4 board, 2 oz Cu

2 Electrical characteristics

($T_{CASE} = 25\text{ °C}$ unless otherwise specified)

Table 4. On/off states

Symbol	Parameter	Test conditions	Min.	Typ.	Max.	Unit
$V_{(BR)DSS}$	Drain-source breakdown voltage	$I_D = 250\ \mu\text{A}$, $V_{GS} = 0$	100			V
I_{DSS}	Zero gate voltage drain current ($V_{GS} = 0$)	$V_{DS} = \text{Max rating}$, $V_{DS} = \text{Max rating @ } 125\text{°C}$			1 10	μA μA
I_{GSS}	Gate body leakage current ($V_{DS} = 0$)	$V_{GS} = \pm 20\ \text{V}$			± 100	nA
$V_{GS(th)}$	Gate threshold voltage	$V_{DS} = V_{GS}$, $I_D = 250\ \mu\text{A}$	2		4	V
$R_{DS(on)}$	Static drain-source on resistance	$V_{GS} = 10\text{V}$, $I_D = 60\ \text{A}$ ⁽¹⁾		0.009	0.0105	Ω

1. For TO-220FP $I_D = 40\ \text{A}$

Table 5. Dynamic

Symbol	Parameter	Test conditions	Min.	Typ.	Max.	Unit
g_{fs} ⁽¹⁾	Forward transconductance	$V_{DS} = 25\ \text{V}$, $I_D = 60\ \text{A}$	-	90		S
C_{iss}	Input capacitance	$V_{DS} = 25\ \text{V}$, $f = 1\ \text{MHz}$, $V_{GS} = 0$	-	5200		pF
C_{oss}	Output capacitance					
C_{rss}	Reverse transfer capacitance					
Q_g	Total gate charge	$V_{DD} = 80\ \text{V}$, $I_D = 120\ \text{A}$	-	172	233	nC
Q_{gs}	Gate-source charge	$V_{GS} = 10\ \text{V}$				
Q_{gd}	Gate-drain charge	(see Figure 16)				

1. Pulsed: pulse duration=300 μs , duty cycle 1.5%

Table 6. Switching times

Symbol	Parameter	Test conditions	Min.	Typ.	Max.	Unit	
$t_{d(on)}$	Turn-on delay time	$V_{DD}=50\text{ V}$, $I_D=60\text{ A}$, $R_G=4.7\ \Omega$, $V_{GS}=10\text{ V}$ <i>(see Figure 15)</i>		25		ns	
t_r	Rise time			90		ns	
$t_{d(off)}$	Turn-off delay time				132		ns
t_f	Fall time				68		ns

Table 7. Source drain diode

Symbol	Parameter	Test conditions	Min.	Typ.	Max.	Unit
I_{SD}	Source-drain current		-		110	A
$I_{SDM}^{(1)}$	Source-drain current (pulsed)		-		440	A
$V_{SD}^{(2)}$	Forward on voltage	$I_{SD}=120\text{ A}$, $V_{GS}=0$	-		1.3	V
t_{rr}	Reverse recovery time	$I_{SD}=120\text{ A}$, $di/dt = 100\text{ A}/\mu\text{s}$, $V_{DD}=40\text{ V}$, $T_j=150\text{ }^\circ\text{C}$ <i>(see Figure 20)</i>		152		ns
Q_{rr}	Reverse recovery charge			760		nC
I_{RRM}	Reverse recovery current				10	

1. Pulse width limited by safe operating area
2. Pulsed: pulse duration=300 μs , duty cycle 1.5%

2.1 Electrical characteristics (curves)

Figure 2. Safe operating area

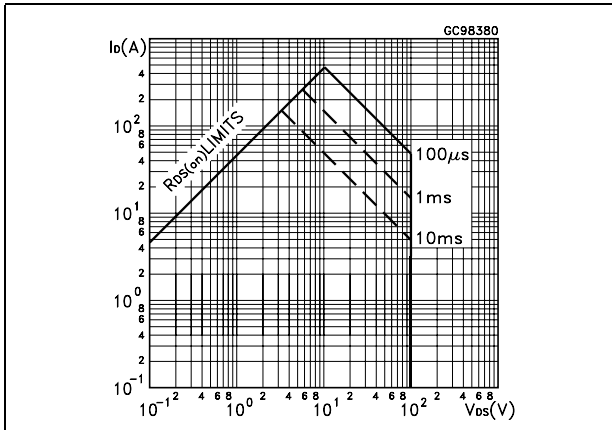

Figure 3. Thermal impedance

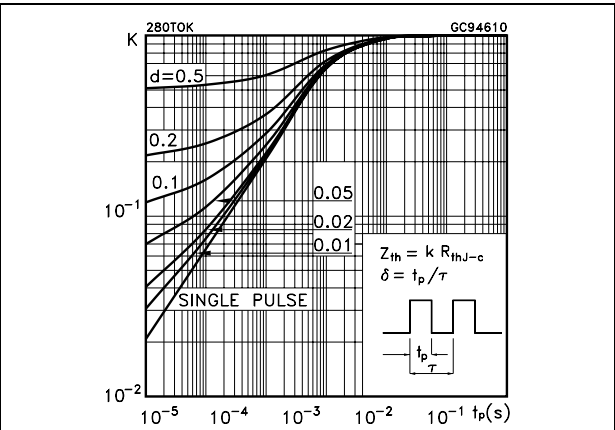

Figure 4. Safe operating area for TO-220FP

Figure 5. Thermal impedance for TO-220FP

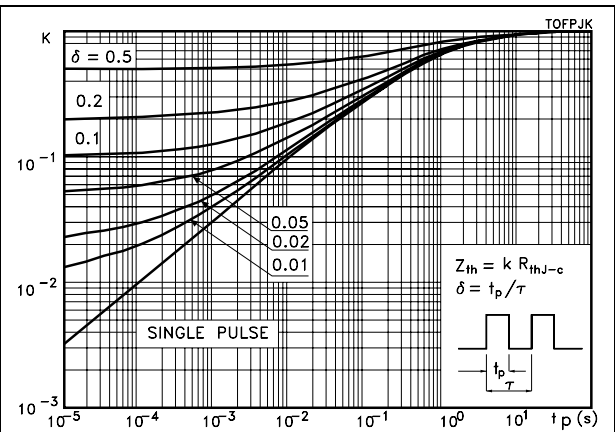
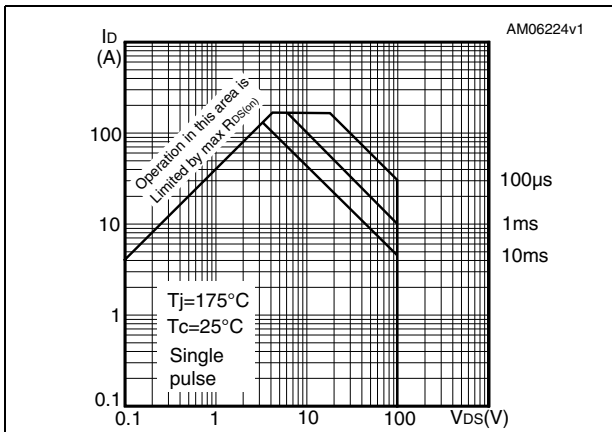

Figure 6. Output characteristics

Figure 7. Transfer characteristics

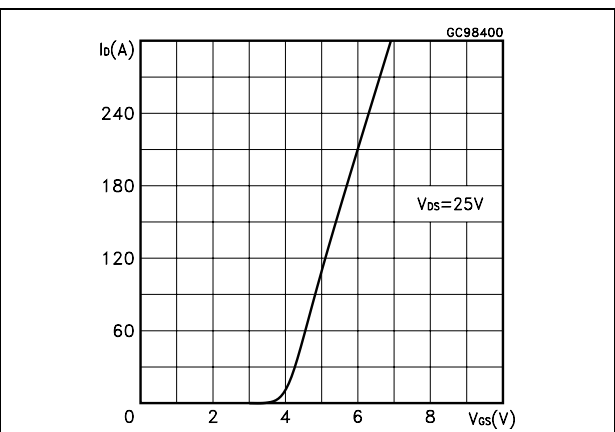
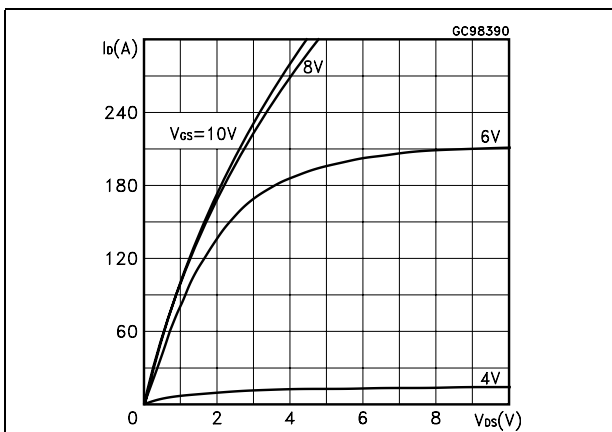

Figure 8. Normalized B_{VDSS} vs temperature

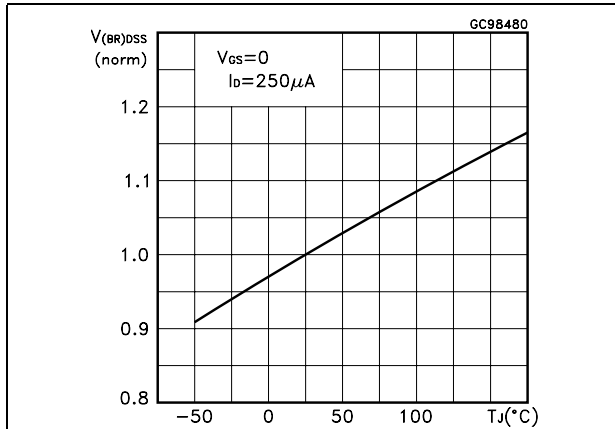

Figure 9. Static drain-source on resistance

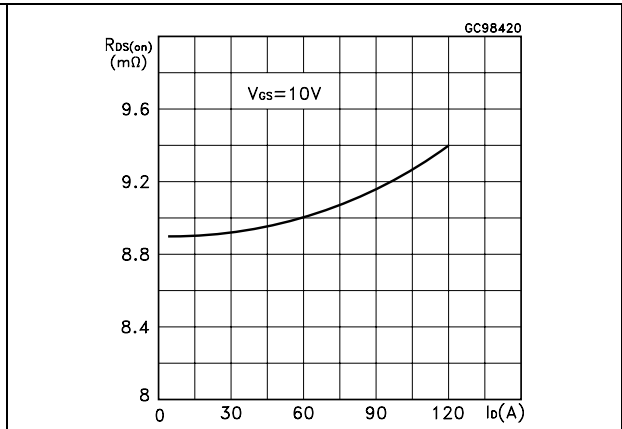

Figure 10. Gate charge vs gate-source voltage

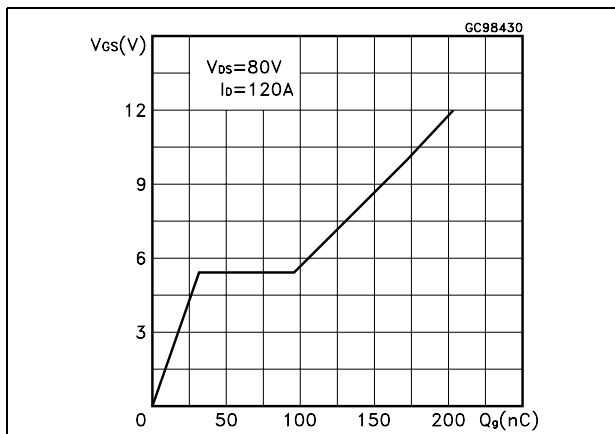

Figure 11. Capacitance variations

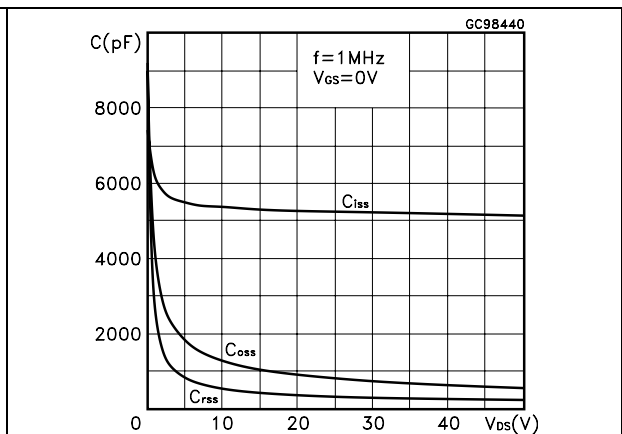

Figure 12. Normalized gate threshold voltage vs temperature

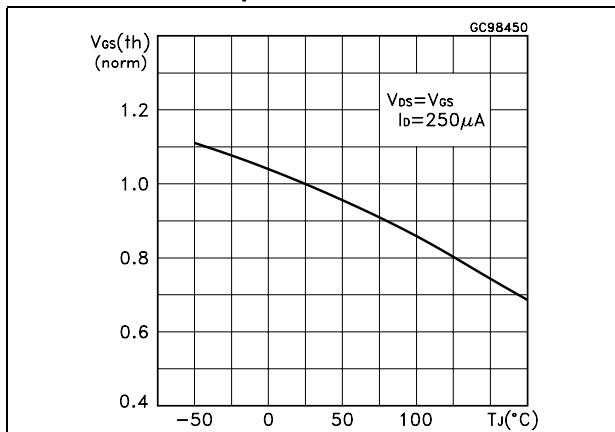

Figure 13. Normalized on resistance vs temperature

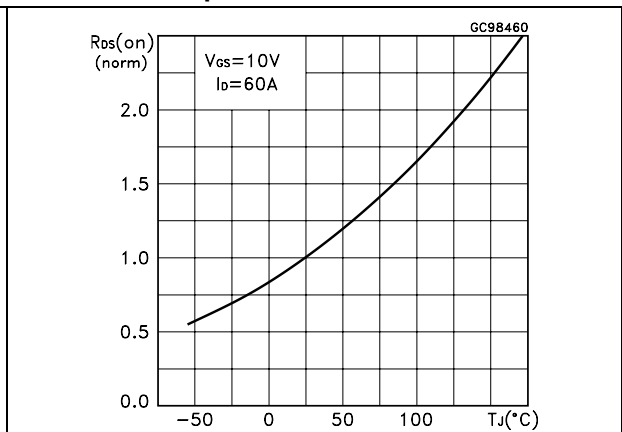
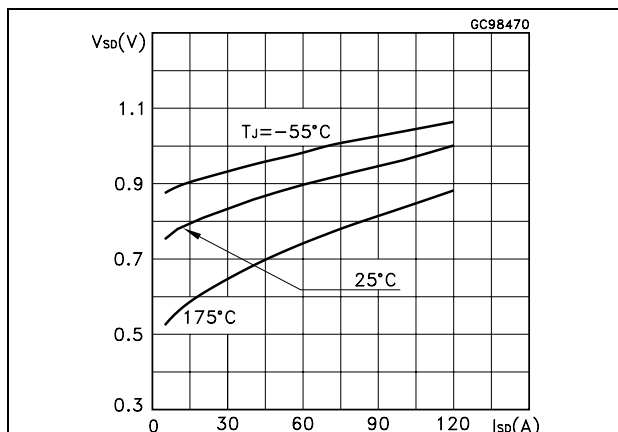
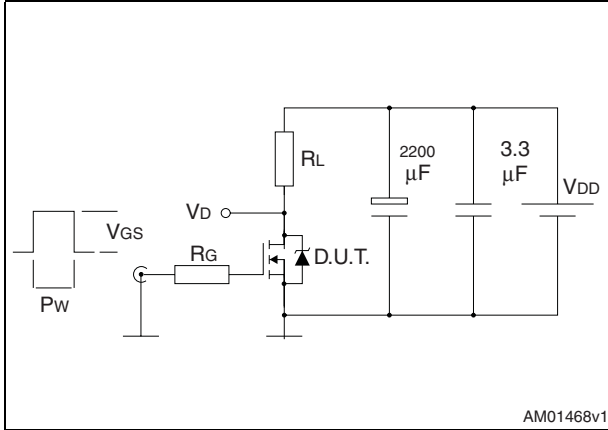

Figure 14. Source-drain diode forward characteristics



3 Test circuits

Figure 15. Switching times test circuit for resistive load



AM01468v1

Figure 16. Gate charge test circuit

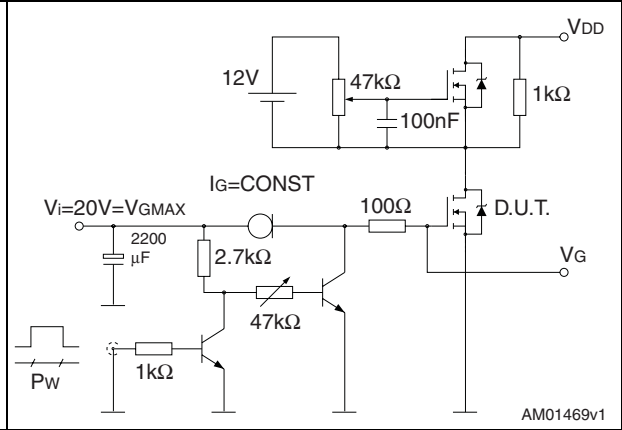

AM01469v1

Figure 17. Test circuit for inductive load switching and diode recovery times

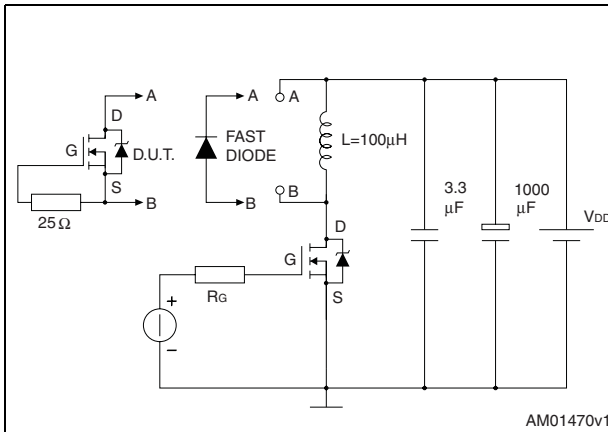

AM01470v1

Figure 18. Unclamped inductive load test circuit

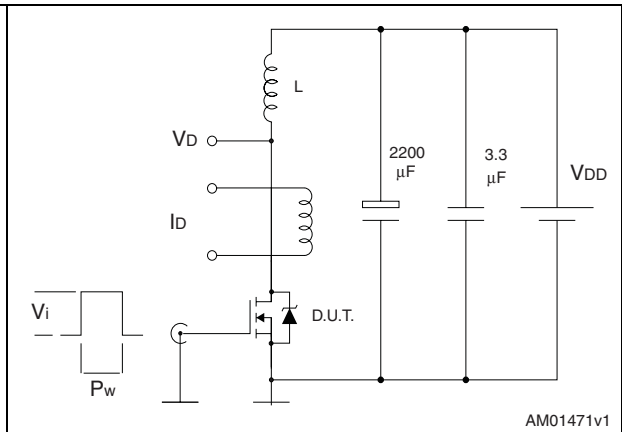

AM01471v1

Figure 19. Unclamped inductive waveform

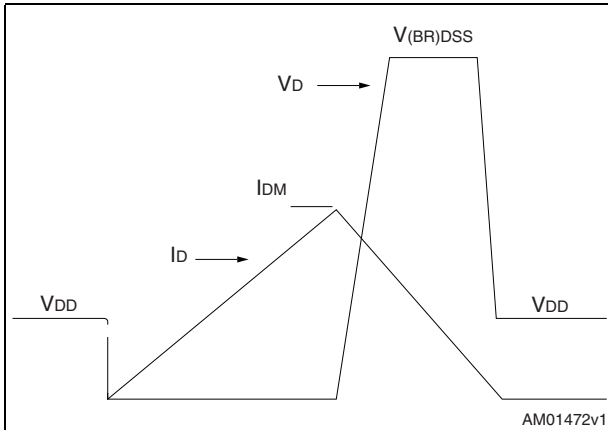

AM01472v1

Figure 20. Switching time waveform

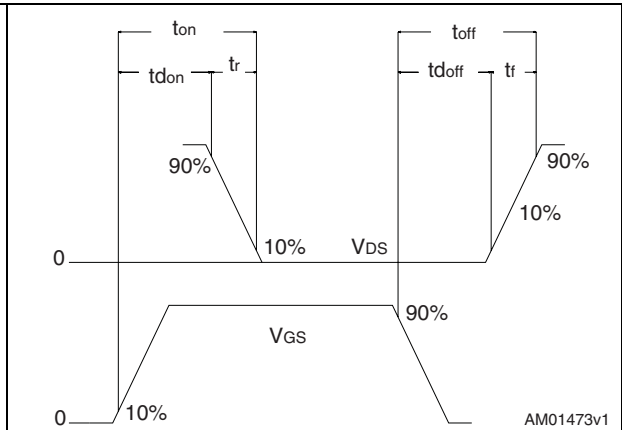

AM01473v1

4 Package mechanical data

In order to meet environmental requirements, ST offers these devices in different grades of ECOPACK® packages, depending on their level of environmental compliance. ECOPACK® specifications, grade definitions and product status are available at: www.st.com. ECOPACK is an ST trademark.

Table 8. TO-220FP mechanical data

Dim.	mm		
	Min.	Typ.	Max.
A	4.4		4.6
B	2.5		2.7
D	2.5		2.75
E	0.45		0.7
F	0.75		1
F1	1.15		1.70
F2	1.15		1.70
G	4.95		5.2
G1	2.4		2.7
H	10		10.4
L2		16	
L3	28.6		30.6
L4	9.8		10.6
L5	2.9		3.6
L6	15.9		16.4
L7	9		9.3
Dia	3		3.2

Figure 21. TO-220FP drawing

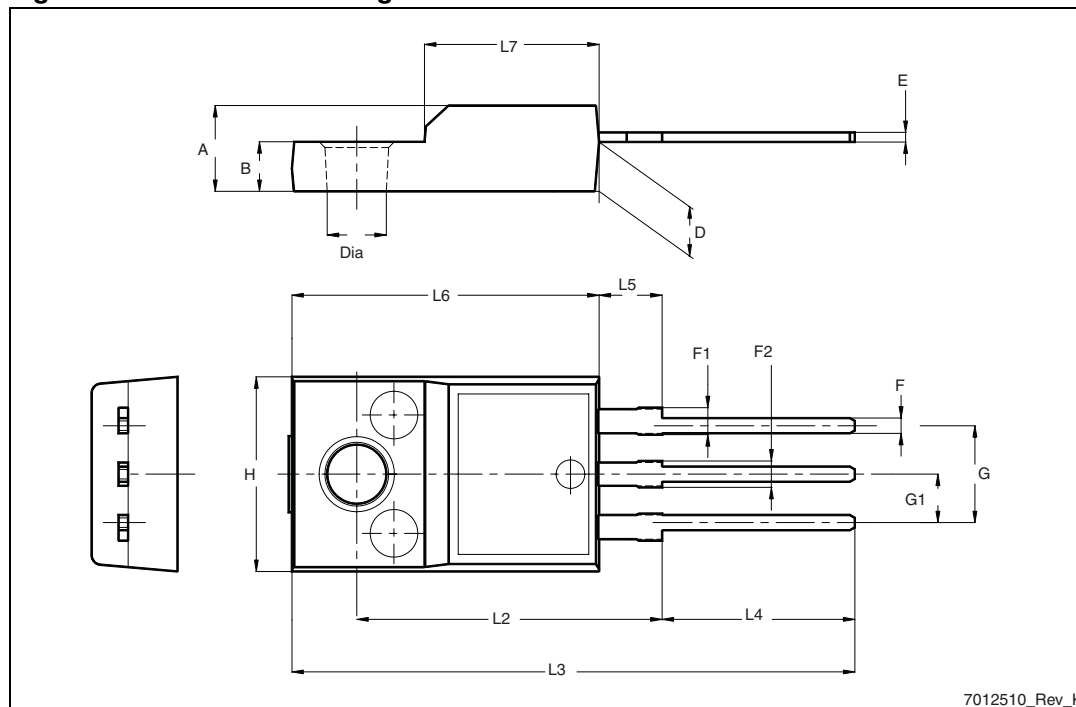

7012510_Rev_K

Table 9. D²PAK (TO-263) mechanical data

Dim.	mm		
	Min.	Typ.	Max.
A	4.40		4.60
A1	0.03		0.23
b	0.70		0.93
b2	1.14		1.70
c	0.45		0.60
c2	1.23		1.36
D	8.95		9.35
D1	7.50		
E	10		10.40
E1	8.50		
e		2.54	
e1	4.88		5.28
H	15		15.85
J1	2.49		2.69
L	2.29		2.79
L1	1.27		1.40
L2	1.30		1.75
R		0.4	
V2	0°		8°

Figure 22. D²PAK (TO-263) drawing

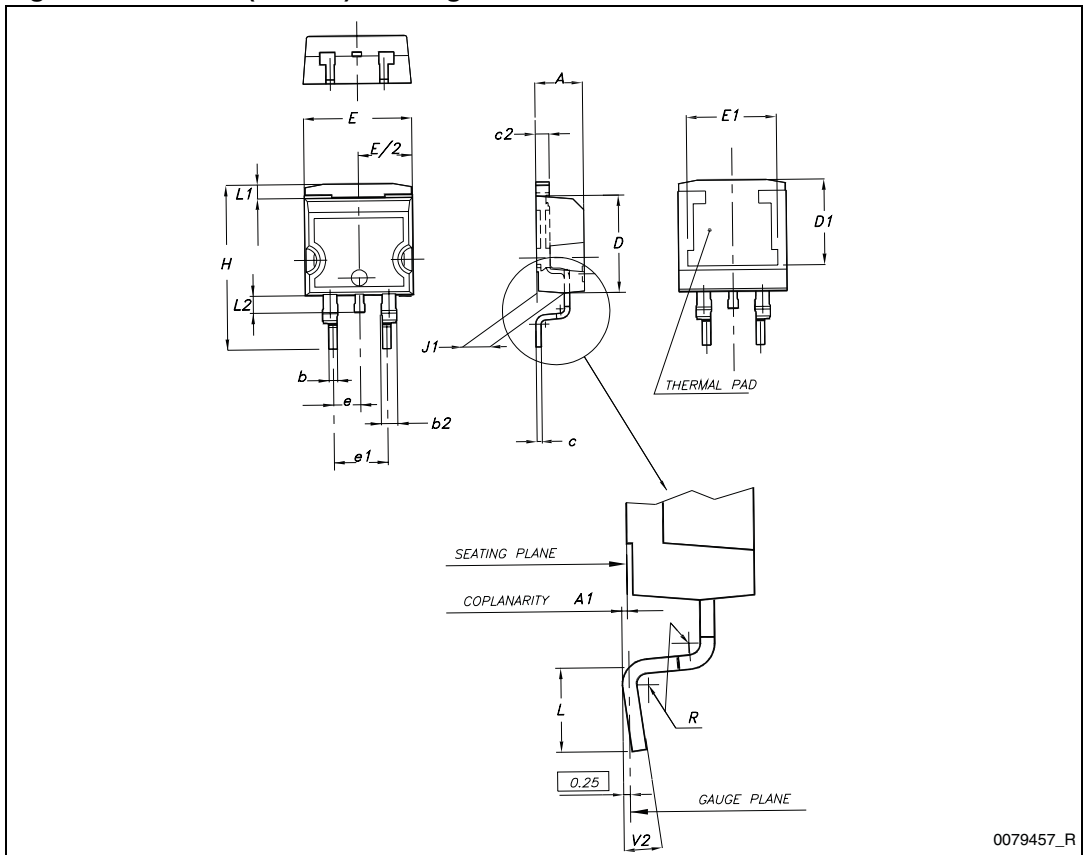
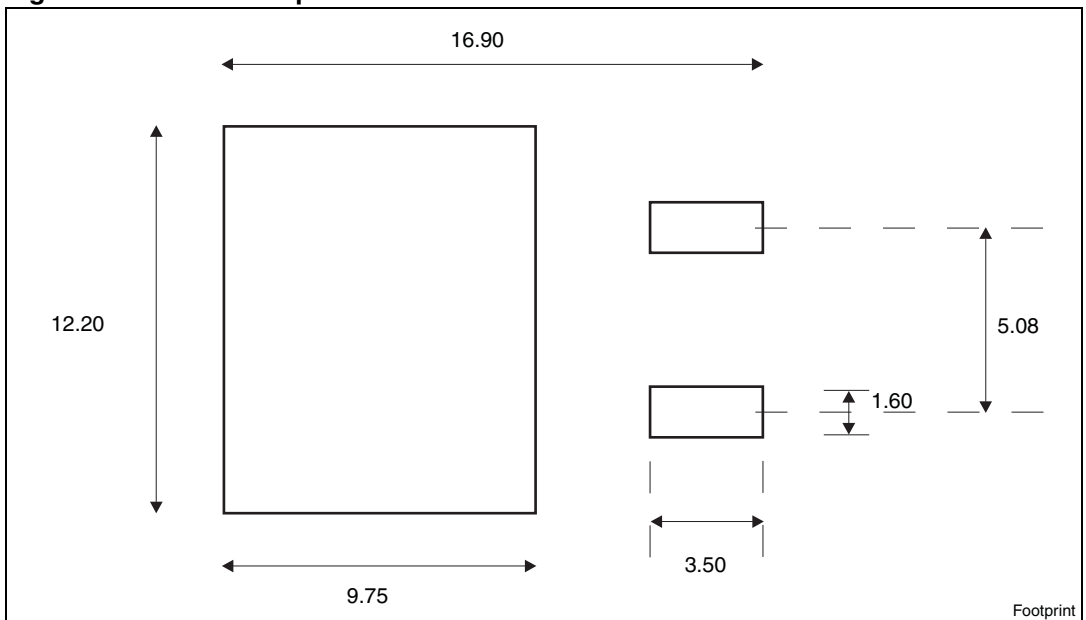

Figure 23. D²PAK footprint^(a)



a. All dimension are in millimeters

Table 10. TO-220 type A mechanical data

Dim.	mm		
	Min.	Typ.	Max.
A	4.40		4.60
b	0.61		0.88
b1	1.14		1.70
c	0.48		0.70
D	15.25		15.75
D1		1.27	
E	10		10.40
e	2.40		2.70
e1	4.95		5.15
F	1.23		1.32
H1	6.20		6.60
J1	2.40		2.72
L	13		14
L1	3.50		3.93
L20		16.40	
L30		28.90	
ØP	3.75		3.85
Q	2.65		2.95

Figure 24. TO-220 type A drawing

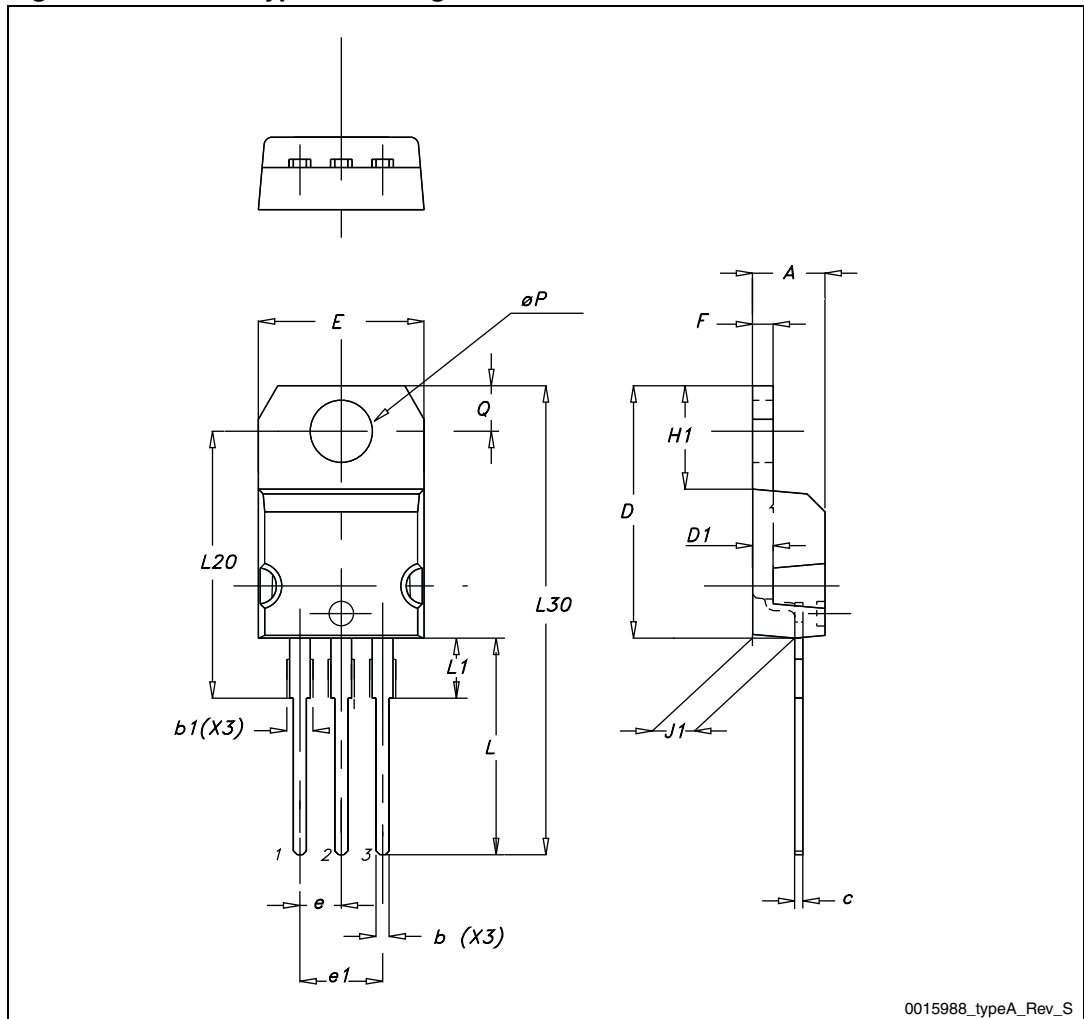
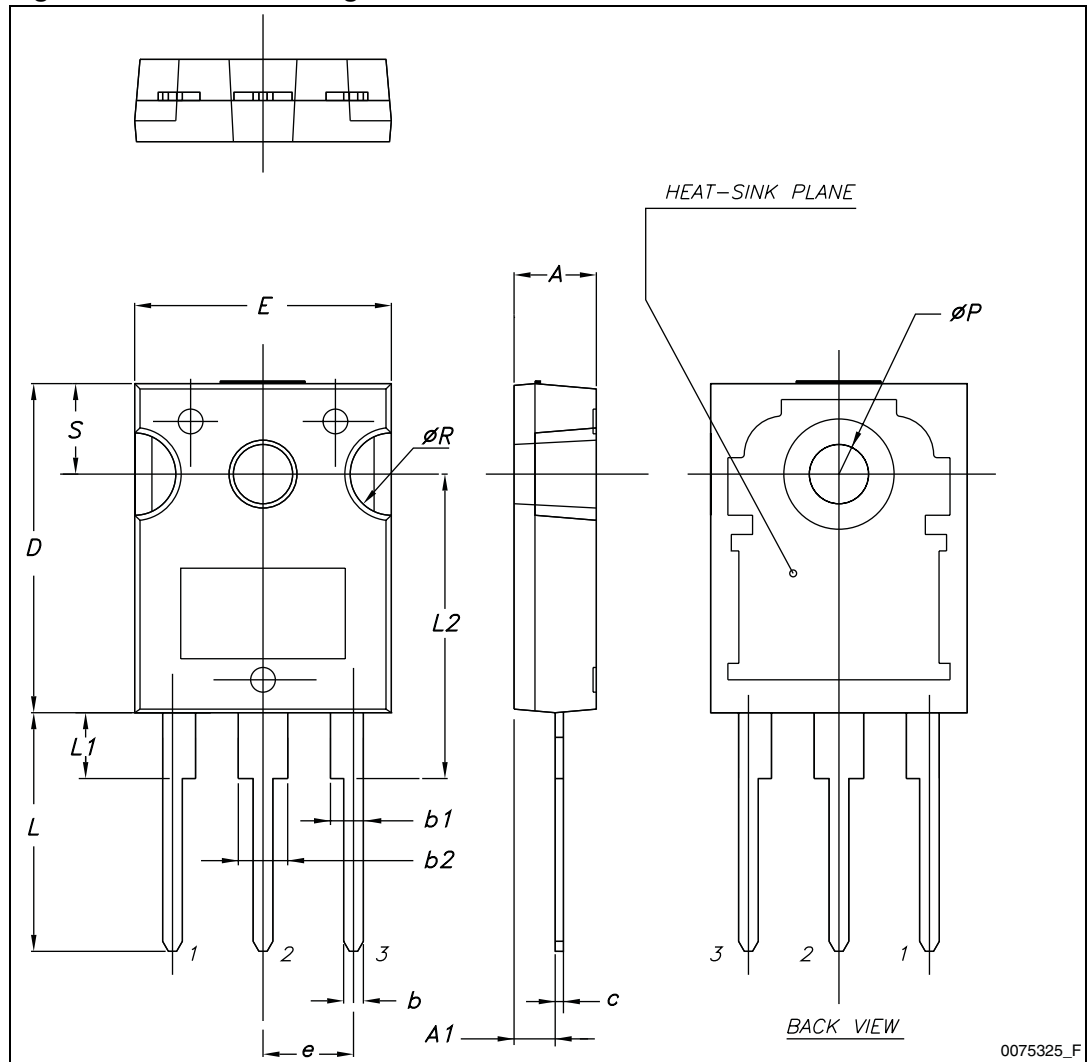

Table 11. TO-247 mechanical data

Dim.	mm		
	Min.	Typ.	Max.
A	4.85		5.15
A1	2.20		2.60
b	1.0		1.40
b1	2.0		2.40
b2	3.0		3.40
c	0.40		0.80
D	19.85		20.15
E	15.45		15.75
e		5.45	
L	14.20		14.80
L1	3.70		4.30
L2		18.50	
ØP	3.55		3.65
ØR	4.50		5.50
S		5.50	

Figure 25. TO-247 drawing



5 Packaging mechanical data

Table 12. D²PAK (TO-263) tape and reel mechanical data

Tape			Reel		
Dim.	mm		Dim.	mm	
	Min.	Max.		Min.	Max.
A0	10.5	10.7	A		330
B0	15.7	15.9	B	1.5	
D	1.5	1.6	C	12.8	13.2
D1	1.59	1.61	D	20.2	
E	1.65	1.85	G	24.4	26.4
F	11.4	11.6	N	100	
K0	4.8	5.0	T		30.4
P0	3.9	4.1			
P1	11.9	12.1	Base qty		1000
P2	1.9	2.1	Bulk qty		1000
R	50				
T	0.25	0.35			
W	23.7	24.3			

Figure 26. Tape

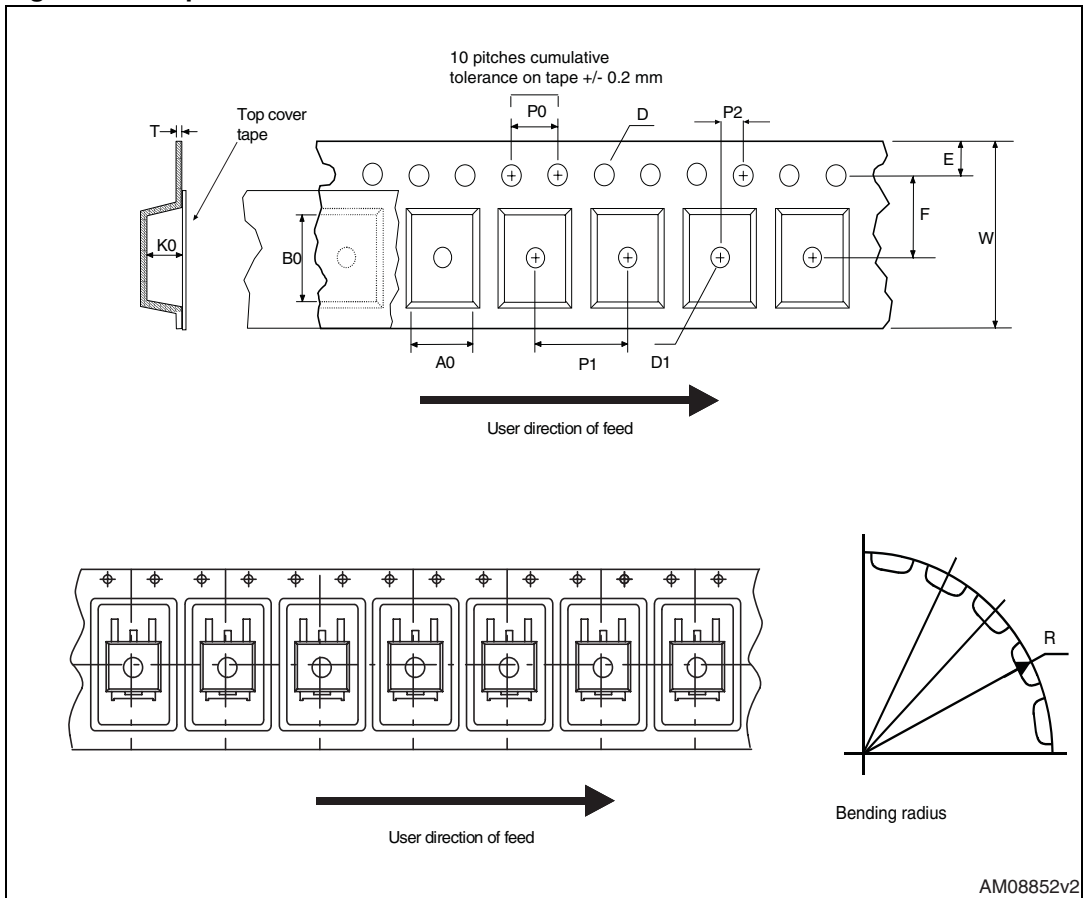
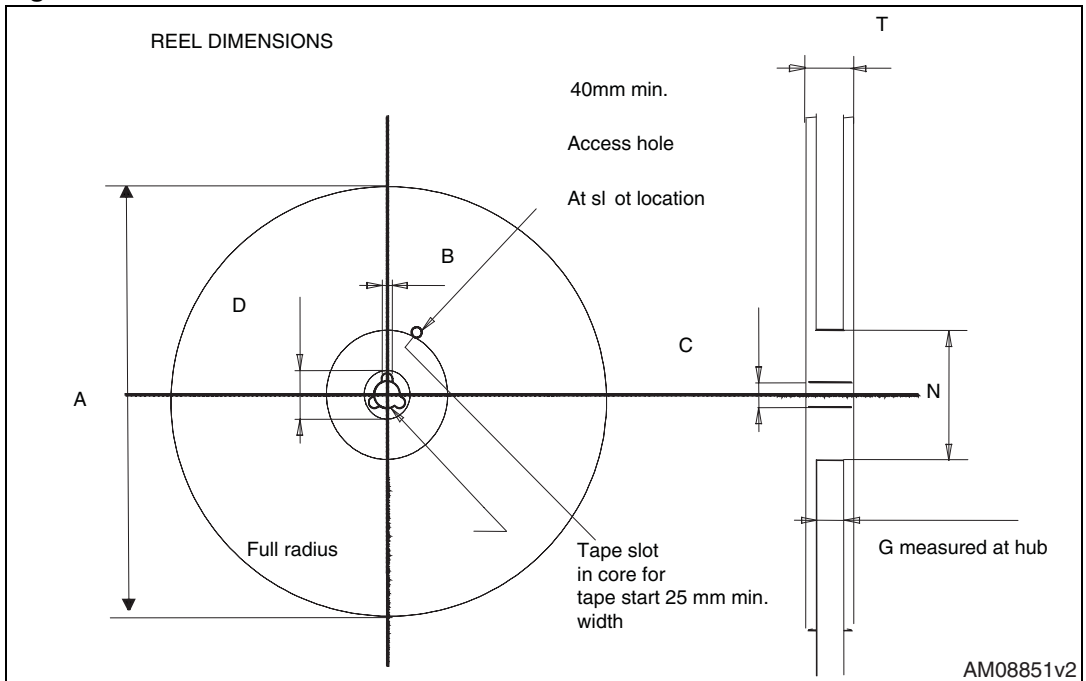

Figure 27. Reel



6 Revision history

Table 13. Revision history

Date	Revision	Changes
20-Mar-2006	2	Preliminary datasheet
31-Mar-2006	3	Typing error
19-Jun-2006	4	New template, no content change
28-Jun-2006	5	New I_D value on Table 2
05-Oct-2006	6	New value on Table 7
11-May-2011	7	Added new package and mechanicala data: TO-220FP.

Please Read Carefully:

Information in this document is provided solely in connection with ST products. STMicroelectronics NV and its subsidiaries ("ST") reserve the right to make changes, corrections, modifications or improvements, to this document, and the products and services described herein at any time, without notice.

All ST products are sold pursuant to ST's terms and conditions of sale.

Purchasers are solely responsible for the choice, selection and use of the ST products and services described herein, and ST assumes no liability whatsoever relating to the choice, selection or use of the ST products and services described herein.

No license, express or implied, by estoppel or otherwise, to any intellectual property rights is granted under this document. If any part of this document refers to any third party products or services it shall not be deemed a license grant by ST for the use of such third party products or services, or any intellectual property contained therein or considered as a warranty covering the use in any manner whatsoever of such third party products or services or any intellectual property contained therein.

UNLESS OTHERWISE SET FORTH IN ST'S TERMS AND CONDITIONS OF SALE ST DISCLAIMS ANY EXPRESS OR IMPLIED WARRANTY WITH RESPECT TO THE USE AND/OR SALE OF ST PRODUCTS INCLUDING WITHOUT LIMITATION IMPLIED WARRANTIES OF MERCHANTABILITY, FITNESS FOR A PARTICULAR PURPOSE (AND THEIR EQUIVALENTS UNDER THE LAWS OF ANY JURISDICTION), OR INFRINGEMENT OF ANY PATENT, COPYRIGHT OR OTHER INTELLECTUAL PROPERTY RIGHT.

UNLESS EXPRESSLY APPROVED IN WRITING BY AN AUTHORIZED ST REPRESENTATIVE, ST PRODUCTS ARE NOT RECOMMENDED, AUTHORIZED OR WARRANTED FOR USE IN MILITARY, AIR CRAFT, SPACE, LIFE SAVING, OR LIFE SUSTAINING APPLICATIONS, NOR IN PRODUCTS OR SYSTEMS WHERE FAILURE OR MALFUNCTION MAY RESULT IN PERSONAL INJURY, DEATH, OR SEVERE PROPERTY OR ENVIRONMENTAL DAMAGE. ST PRODUCTS WHICH ARE NOT SPECIFIED AS "AUTOMOTIVE GRADE" MAY ONLY BE USED IN AUTOMOTIVE APPLICATIONS AT USER'S OWN RISK.

Resale of ST products with provisions different from the statements and/or technical features set forth in this document shall immediately void any warranty granted by ST for the ST product or service described herein and shall not create or extend in any manner whatsoever, any liability of ST.

ST and the ST logo are trademarks or registered trademarks of ST in various countries.

Information in this document supersedes and replaces all information previously supplied.

The ST logo is a registered trademark of STMicroelectronics. All other names are the property of their respective owners.

© 2011 STMicroelectronics - All rights reserved

STMicroelectronics group of companies

Australia - Belgium - Brazil - Canada - China - Czech Republic - Finland - France - Germany - Hong Kong - India - Israel - Italy - Japan - Malaysia - Malta - Morocco - Philippines - Singapore - Spain - Sweden - Switzerland - United Kingdom - United States of America

www.st.com

