PIC16F684 Rev. A Silicon/Data Sheet Errata

The PIC16F684 parts you have received conform functionally to the Device Data Sheet (DS41202D), except for the anomalies described below.

Microchip intends to address all issues listed here in future revisions of the **PIC16F684 silicon**.

1. Module: Resets (when WDT times out)

If the OPTION_REG bits, PS<2:0>, are clear, multiple spurious Resets can occur when the WDT times out. These Resets can occur even when the PSA bit is clear, assigning the prescaler to the Timer0.

Work around

If a CLRWDT instruction is issued before the WDT times out and before the OPTION register is modified, this problem is eliminated.

Date Codes that pertain to this issue:

All engineering and production devices.

2. Module: Data EEPROM Memory

The EEIF flag may be cleared inadvertently when performing operations on the PIR1 register simultaneously with the completion of an EEPROM write. This condition occurs when the EEPROM write timer completes at the same moment that the PIR1 register operation is executed. Register operations are those that have the PIR1 register as the destination and include, but are not limited to, BSF, BCF, ANDWF, IORWF and XORWF.

Work around

1. Avoid operations on the PIR1 register when writing to the EEPROM memory.
2. Poll the WR bit (EECON1<1>) to determine when the write is complete.
3. Use a timer interrupt to catch any instances when the EEIF flag is inadvertently cleared. The timer interrupt should be set longer than 8 ms. If EEIF fails, then the timer interrupt occurs as a default time out. The WR and WRERR flags are checked as part of the timer interrupt service routine to verify the EEPROM write success.

4. If periodic interrupts are occurring in addition to the EEIF interrupts, then use a secondary flag to sense write completion. The secondary flag is set whenever EEPROM writes are active. An EEPROM write completion is indicated when the secondary flag is set and the WR flag is clear.

3. Module: ECCP with Auto-Shutdown (Silicon Rev. A4 and B2)

The PIC16F684 Rev. A4 silicon for the ECCP Auto-Shutdown is connected to the C1IF and C2IF flags. See Figures 8-2 and 8-3 on the following page.

Rev. A4's auto-shutdown connection to C1IF and C2IF causes the auto-shutdown to incorrectly operate synchronously. Additionally, reads of CMCON0 will incorrectly clear an auto-shutdown event.

Work around

Rev. A4 Silicon

- 1) Poll the CxOUT bit until it is low.
- 2) Read CMCON1 to precondition CxIF.
- 3) If CMCON0 is read while CxOUT is changing, repeat steps 1 and 2.

Fix

Rev. B2 Silicon

The Silicon Rev. B2 device (now shipping) has moved the auto-shutdown connection from CxIF to CxOUT. This will eliminate the synchronous shutdown and simplify the use of the comparator for a shutdown event. Figure 1 shows the function of auto-shutdown before and after the device revision.

PIC16F684

FIGURE 8-2: COMPARATOR C1 OUTPUT BLOCK DIAGRAM

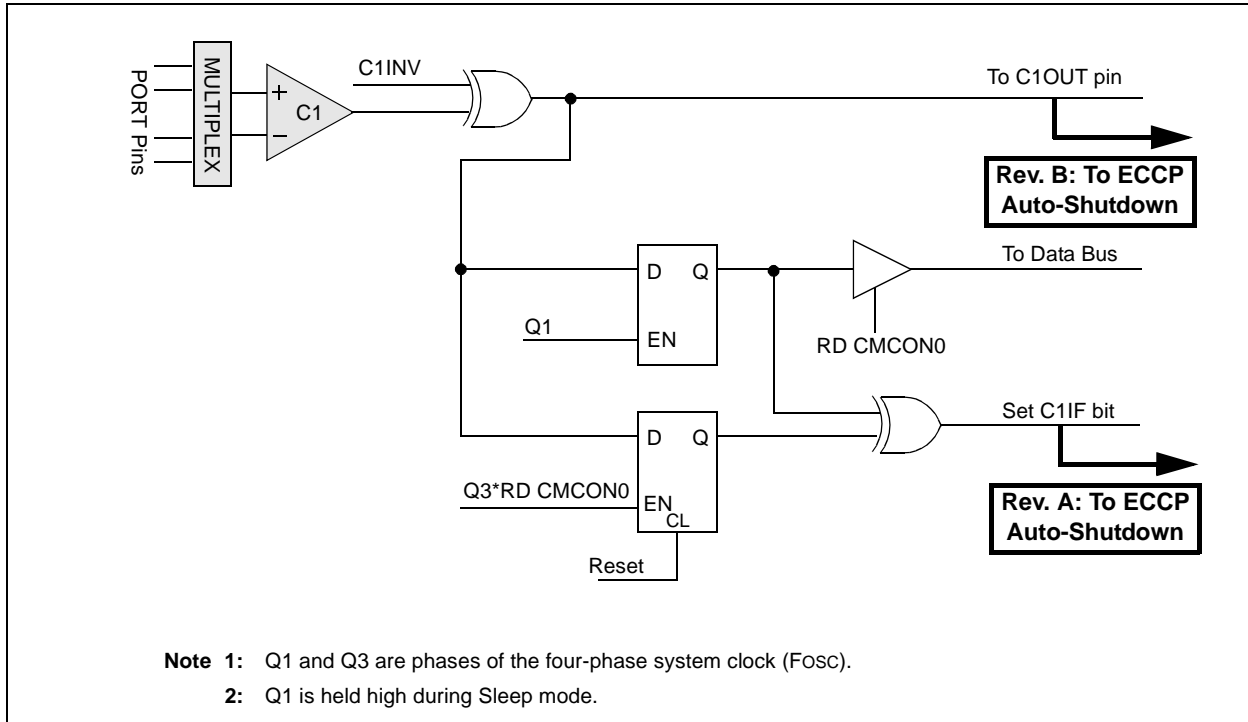

FIGURE 8-3: COMPARATOR C2 OUTPUT BLOCK DIAGRAM

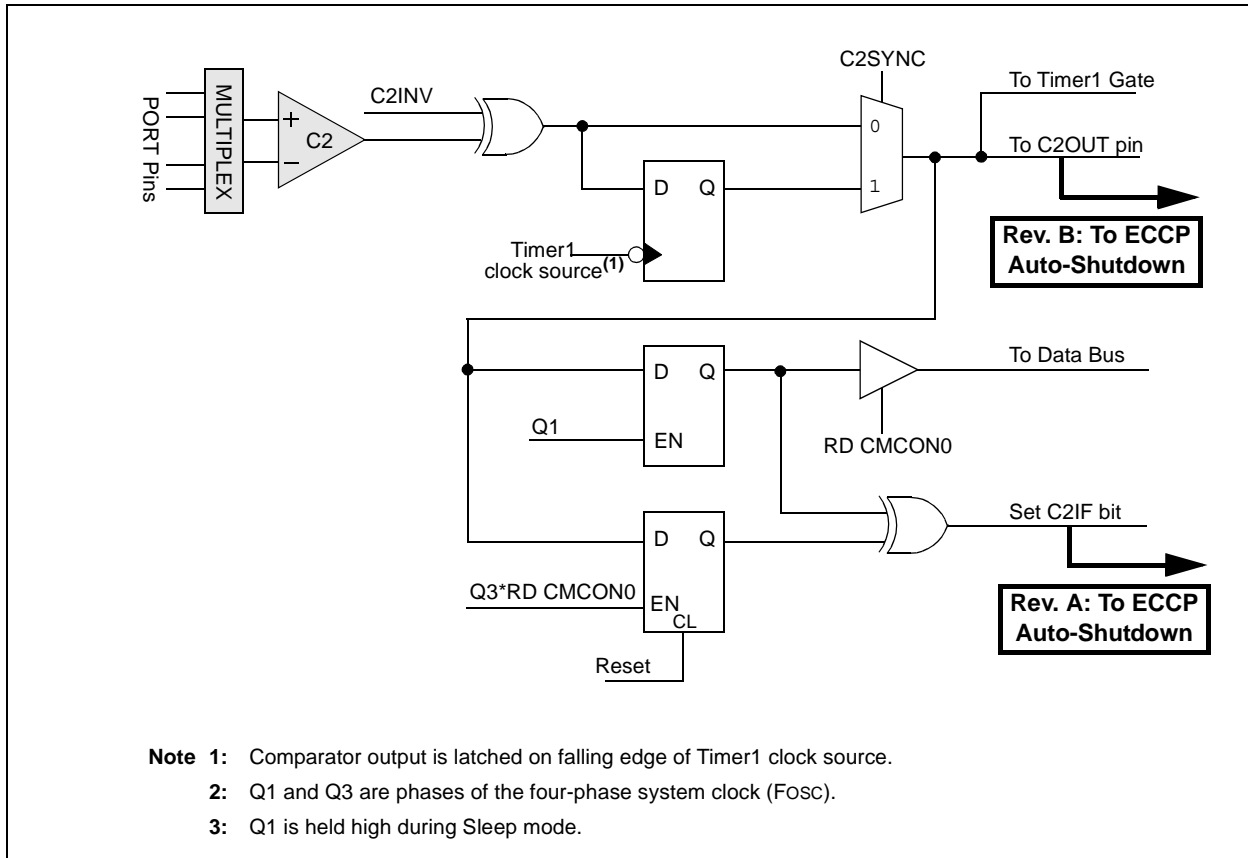
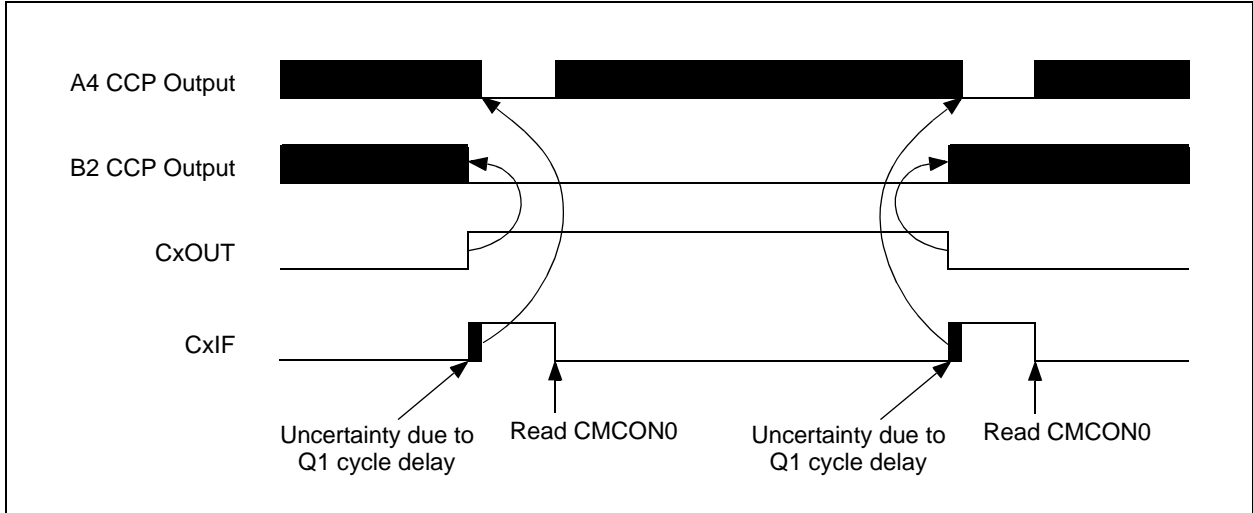

FIGURE 1: SILICON REVISION A4 VS. REVISION B2



PIC16F684

Clarifications/Corrections to the Data Sheet:

In the Device Data Sheet (41202D), the following clarifications and corrections should be noted.

N/A.

REVISION HISTORY

Rev A Document (7/2004)

First revision of this document. Changes made to Section 11.1.1, "CCP1 Pin Configuration".

Rev B Document (08/2004)

Issue 1 – When OPTION_REG bits, PS<2:0>, are clear, multiple spurious Resets can occur when the WDT times out.

Rev C Document (11/2004)

Added Module 2: "Data EEPROM Memory" for PIC16F684 silicon.

Rev D Document (7/2005)

Data Sheet Clarifications/Corrections Section: Added Module 2: New 4x4 QFN Package added.

Rev E Document (7/2006)

Added Module 3: ECCP with Auto-Shutdown (Silicon Rev. A4 and B2).

Clarifications/Corrections to the Data Sheet: Removed Items 1 and 2, which have been incorporated into the data sheet.

Note the following details of the code protection feature on Microchip devices:

- Microchip products meet the specification contained in their particular Microchip Data Sheet.
- Microchip believes that its family of products is one of the most secure families of its kind on the market today, when used in the intended manner and under normal conditions.
- There are dishonest and possibly illegal methods used to breach the code protection feature. All of these methods, to our knowledge, require using the Microchip products in a manner outside the operating specifications contained in Microchip's Data Sheets. Most likely, the person doing so is engaged in theft of intellectual property.
- Microchip is willing to work with the customer who is concerned about the integrity of their code.
- Neither Microchip nor any other semiconductor manufacturer can guarantee the security of their code. Code protection does not mean that we are guaranteeing the product as "unbreakable."

Code protection is constantly evolving. We at Microchip are committed to continuously improving the code protection features of our products. Attempts to break Microchip's code protection feature may be a violation of the Digital Millennium Copyright Act. If such acts allow unauthorized access to your software or other copyrighted work, you may have a right to sue for relief under that Act.

Information contained in this publication regarding device applications and the like is provided only for your convenience and may be superseded by updates. It is your responsibility to ensure that your application meets with your specifications. MICROCHIP MAKES NO REPRESENTATIONS OR WARRANTIES OF ANY KIND WHETHER EXPRESS OR IMPLIED, WRITTEN OR ORAL, STATUTORY OR OTHERWISE, RELATED TO THE INFORMATION, INCLUDING BUT NOT LIMITED TO ITS CONDITION, QUALITY, PERFORMANCE, MERCHANTABILITY OR FITNESS FOR PURPOSE. Microchip disclaims all liability arising from this information and its use. Use of Microchip devices in life support and/or safety applications is entirely at the buyer's risk, and the buyer agrees to defend, indemnify and hold harmless Microchip from any and all damages, claims, suits, or expenses resulting from such use. No licenses are conveyed, implicitly or otherwise, under any Microchip intellectual property rights.

Trademarks

The Microchip name and logo, the Microchip logo, Accuron, dsPIC, KEELOQ, microID, MPLAB, PIC, PICmicro, PICSTART, PRO MATE, PowerSmart, rfPIC, and SmartShunt are registered trademarks of Microchip Technology Incorporated in the U.S.A. and other countries.

AmpLab, FilterLab, Migratable Memory, MXDEV, MXLAB, SEEVAL, SmartSensor and The Embedded Control Solutions Company are registered trademarks of Microchip Technology Incorporated in the U.S.A.

Analog-for-the-Digital Age, Application Maestro, CodeGuard, dsPICDEM, dsPICDEM.net, dsPICworks, ECAN, ECONOMONITOR, FanSense, FlexROM, fuzzyLAB, In-Circuit Serial Programming, ICSP, ICEPIC, Linear Active Thermistor, Mindi, MiWi, MPASM, MPLIB, MPLINK, PICkit, PICDEM, PICDEM.net, PICLAB, PICtail, PowerCal, PowerInfo, PowerMate, PowerTool, REAL ICE, rfLAB, rfPICDEM, Select Mode, Smart Serial, SmartTel, Total Endurance, UNI/O, WiperLock and ZENA are trademarks of Microchip Technology Incorporated in the U.S.A. and other countries.

SQTP is a service mark of Microchip Technology Incorporated in the U.S.A.

All other trademarks mentioned herein are property of their respective companies.

© 2006, Microchip Technology Incorporated, Printed in the U.S.A., All Rights Reserved.

 Printed on recycled paper.

QUALITY MANAGEMENT SYSTEM
CERTIFIED BY DNV
== ISO/TS 16949:2002 ==

Microchip received ISO/TS-16949:2002 certification for its worldwide headquarters, design and wafer fabrication facilities in Chandler and Tempe, Arizona, Gresham, Oregon and Mountain View, California. The Company's quality system processes and procedures are for its PICmicro® 8-bit MCUs, KEELOQ® code hopping devices, Serial EEPROMs, microperipherals, nonvolatile memory and analog products. In addition, Microchip's quality system for the design and manufacture of development systems is ISO 9001:2000 certified.



WORLDWIDE SALES AND SERVICE

AMERICAS

Corporate Office
2355 West Chandler Blvd.
Chandler, AZ 85224-6199
Tel: 480-792-7200
Fax: 480-792-7277
Technical Support:
<http://support.microchip.com>
Web Address:
www.microchip.com

Atlanta
Alpharetta, GA
Tel: 770-640-0034
Fax: 770-640-0307

Boston
Westborough, MA
Tel: 774-760-0087
Fax: 774-760-0088

Chicago
Itasca, IL
Tel: 630-285-0071
Fax: 630-285-0075

Dallas
Addison, TX
Tel: 972-818-7423
Fax: 972-818-2924

Detroit
Farmington Hills, MI
Tel: 248-538-2250
Fax: 248-538-2260

Kokomo
Kokomo, IN
Tel: 765-864-8360
Fax: 765-864-8387

Los Angeles
Mission Viejo, CA
Tel: 949-462-9523
Fax: 949-462-9608

Santa Clara
Santa Clara, CA
Tel: 408-961-6444
Fax: 408-961-6445

Toronto
Mississauga, Ontario,
Canada
Tel: 905-673-0699
Fax: 905-673-6509

ASIA/PACIFIC

Asia Pacific Office
Suites 3707-14, 37th Floor
Tower 6, The Gateway
Harbour City, Kowloon
Hong Kong
Tel: 852-2401-1200
Fax: 852-2401-3431

Australia - Sydney
Tel: 61-2-9868-6733
Fax: 61-2-9868-6755

China - Beijing
Tel: 86-10-8528-2100
Fax: 86-10-8528-2104

China - Chengdu
Tel: 86-28-8676-6200
Fax: 86-28-8676-6599

China - Fuzhou
Tel: 86-591-8750-3506
Fax: 86-591-8750-3521

China - Hong Kong SAR
Tel: 852-2401-1200
Fax: 852-2401-3431

China - Qingdao
Tel: 86-532-8502-7355
Fax: 86-532-8502-7205

China - Shanghai
Tel: 86-21-5407-5533
Fax: 86-21-5407-5066

China - Shenyang
Tel: 86-24-2334-2829
Fax: 86-24-2334-2393

China - Shenzhen
Tel: 86-755-8203-2660
Fax: 86-755-8203-1760

China - Shunde
Tel: 86-757-2839-5507
Fax: 86-757-2839-5571

China - Wuhan
Tel: 86-27-5980-5300
Fax: 86-27-5980-5118

China - Xian
Tel: 86-29-8833-7250
Fax: 86-29-8833-7256

ASIA/PACIFIC

India - Bangalore
Tel: 91-80-4182-8400
Fax: 91-80-4182-8422

India - New Delhi
Tel: 91-11-4160-8631
Fax: 91-11-4160-8632

India - Pune
Tel: 91-20-2566-1512
Fax: 91-20-2566-1513

Japan - Yokohama
Tel: 81-45-471- 6166
Fax: 81-45-471-6122

Korea - Gumi
Tel: 82-54-473-4301
Fax: 82-54-473-4302

Korea - Seoul
Tel: 82-2-554-7200
Fax: 82-2-558-5932 or
82-2-558-5934

Malaysia - Penang
Tel: 60-4-646-8870
Fax: 60-4-646-5086

Philippines - Manila
Tel: 63-2-634-9065
Fax: 63-2-634-9069

Singapore
Tel: 65-6334-8870
Fax: 65-6334-8850

Taiwan - Hsin Chu
Tel: 886-3-572-9526
Fax: 886-3-572-6459

Taiwan - Kaohsiung
Tel: 886-7-536-4818
Fax: 886-7-536-4803

Taiwan - Taipei
Tel: 886-2-2500-6610
Fax: 886-2-2508-0102

Thailand - Bangkok
Tel: 66-2-694-1351
Fax: 66-2-694-1350

EUROPE

Austria - Wels
Tel: 43-7242-2244-3910
Fax: 43-7242-2244-393

Denmark - Copenhagen
Tel: 45-4450-2828
Fax: 45-4485-2829

France - Paris
Tel: 33-1-69-53-63-20
Fax: 33-1-69-30-90-79

Germany - Munich
Tel: 49-89-627-144-0
Fax: 49-89-627-144-44

Italy - Milan
Tel: 39-0331-742611
Fax: 39-0331-466781

Netherlands - Drunen
Tel: 31-416-690399
Fax: 31-416-690340

Spain - Madrid
Tel: 34-91-708-08-90
Fax: 34-91-708-08-91

UK - Wokingham
Tel: 44-118-921-5869
Fax: 44-118-921-5820