



MICROCHIP

PIC16C63A/65B/73B/74B

PIC16C63A/65B/73B/74B Data Sheet Errata

The PIC16C63A/65B/73B/74B parts you have received conform functionally to the Device Data Sheet (DS30605C), except for the anomalies described below.

None.

PIC16C63A/65B/73B/74B

Clarifications/Corrections to the Data Sheet:

In the Device Data Sheet (DS30605C), the following clarifications and corrections should be noted.

1. Module: SSP (SPI™ Mode)

In Section 10.2 (“SPI Mode”), Figure 10-1 and the note box immediately beneath it have been amended to better demonstrate the Peripheral OE line of the SSP module and describe its relationship to the TRISC<5> bit of PORTC.

Changes are indicated in **bold**.

Note 1: When the SPI module is in Slave mode with \overline{SS} pin control enabled (SSPCON<3:0> = 0100), the SPI module will reset if the \overline{SS} pin is set to VDD.

2: If the SPI is used in Slave mode with CKE = '1', then \overline{SS} pin control must be enabled.

3: When the SPI is in Slave mode with \overline{SS} pin control enabled (SSPCON<3:0> = 0100), the state of the \overline{SS} pin can affect the state read back from the TRISC<5> bit. The Peripheral OE signal from the SSP module into PORTC, controls the state that is read back from the TRISC<5> bit (see Section 5.3 for information on PORTC). If Read-Modify-Write instructions, such as BSF, are performed on the TRISC register while the \overline{SS} pin is high, this will cause the TRISC<5> bit to be set, thus disabling the SDO output.

FIGURE 10-1: SSP BLOCK DIAGRAM (SPI MODE)

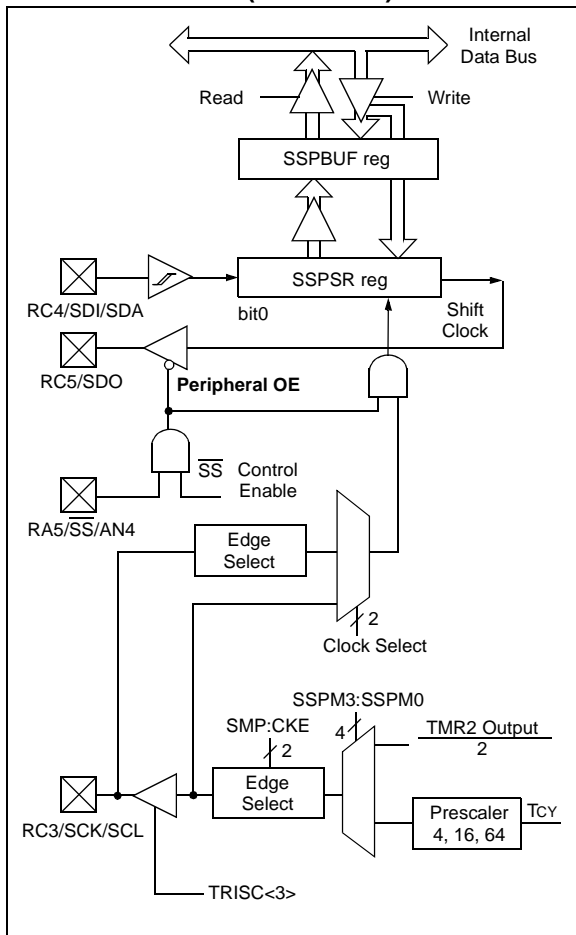

PIC16C63A/65B/73B/74B

2. Module: Packaging (Pinout and Product Identification)

PIC16C63A and PIC16C73B devices are now offered in 28-pin near chip-scale micro lead frame packages (commonly known as “QFN”). This packaging type has been added to the product line since the latest revision of the Device Data Sheet.

The addition of this option requires the following additions to the Device Data Sheet. The referenced figures and tables follow this text.

1. The “Pin Diagram” on page 2 of the Data Sheet is amended with the addition of the 28-pin QFN pinout, shown in Figure 1.

2. Table 3-1 of Section 3.0 (“Architectural Overview”) is replaced with an updated version that adds a column for QFN pin assignments. All new information is indicated in **bold**.
3. Section 18.1 (“Package Marking Information”) is amended to include a marking template and example for 28-pin QFN devices. These are shown in Figure 2.
4. Section 18.0 (“Package Information”) is amended to include the mechanical drawings of the 28-pin QFN package. These are shown in Figure 3 and Figure 4, respectively.
5. Table B-1 (“Device Differences”) is amended to include the 28-pin QFN for the PIC16C63A and PIC16C73B devices.

FIGURE 1: PINOUT DIAGRAM FOR PIC16C63A AND PIC16C73B, 28-PIN QFN

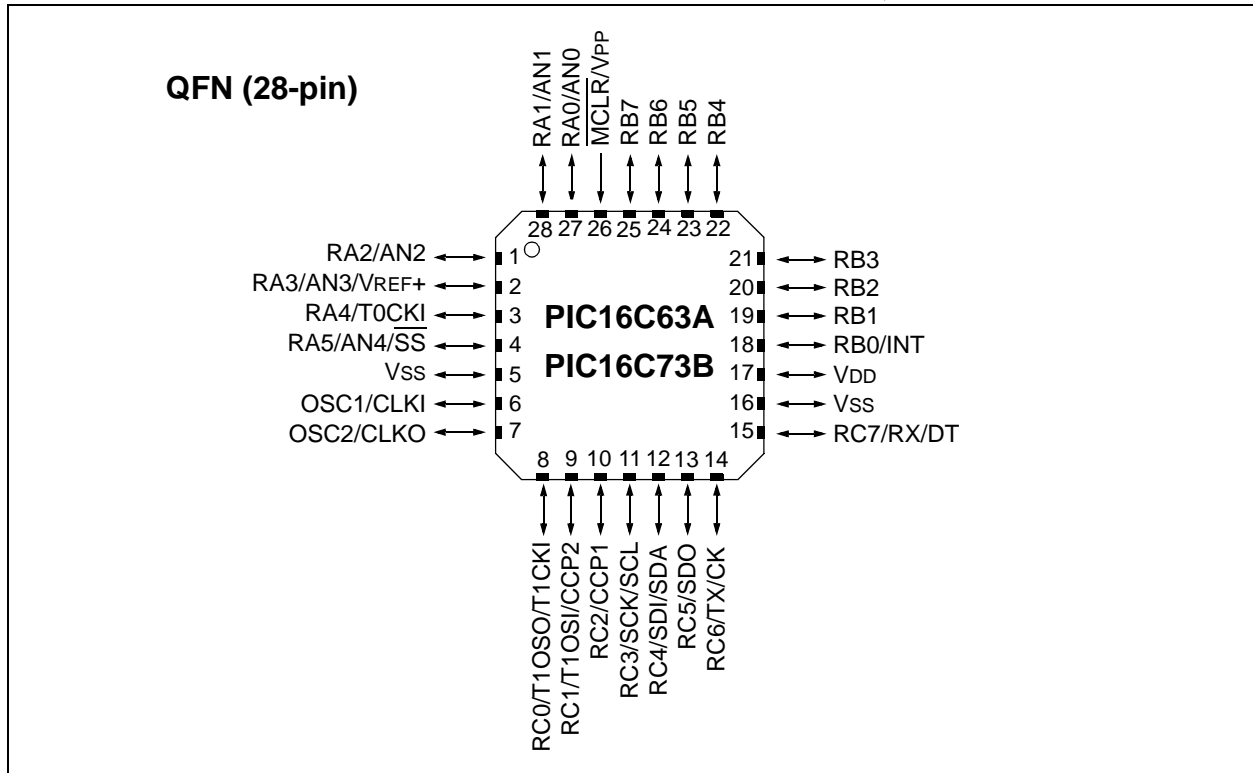
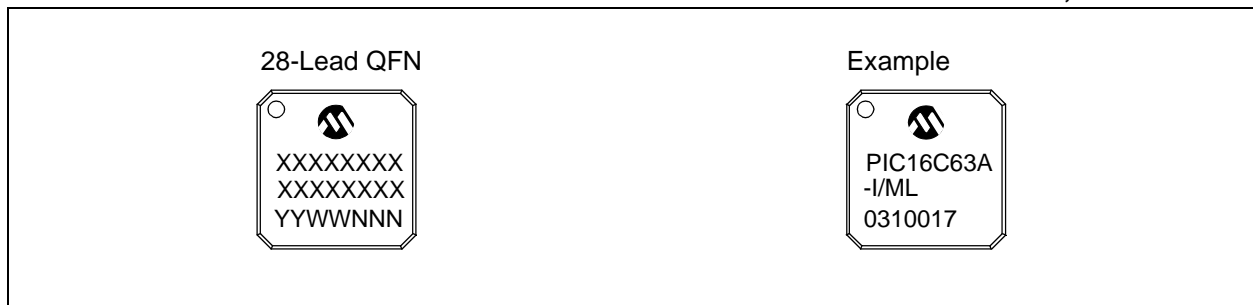

FIGURE 2: PACKAGE MARKING TEMPLATE FOR PIC16C63A AND PIC16C73B, 28-PIN QFN



PIC16C63A/65B/73B/74B

TABLE 3-1: PIC16C63A/73B PINOUT DESCRIPTION

Pin Name	DIP Pin#	SOIC Pin#	QFN Pin#	I/O/P Type	Buffer Type	Description
OSC1/CLKIN	9	9	6	I	ST/CMOS ⁽³⁾	Oscillator crystal input/external clock source input.
OSC2/CLKOUT	10	10	7	O	—	Oscillator crystal output. Connects to crystal or resonator in crystal oscillator mode. In RC mode, the OSC2 pin outputs CLKOUT which has 1/4 the frequency of OSC1, and denotes the instruction cycle rate.
MCLR/VPP	1	1	26	I/P	ST	Master clear (RESET) input or programming voltage input. This pin is an active low RESET to the device.
RA0/AN0 ⁽⁴⁾	2	2	27	I/O	TTL	<p>PORTA is a bidirectional I/O port.</p> <p>RA0 can also be analog input 0⁽⁴⁾.</p> <p>RA1 can also be analog input 1⁽⁴⁾.</p> <p>RA2 can also be analog input 2⁽⁴⁾.</p> <p>RA3 can also be analog input 3 or analog reference voltage⁽⁴⁾.</p> <p>RA4 can also be the clock input to the Timer0 module. Output is open drain type.</p> <p>RA5 can also be analog input 4⁽⁴⁾ or the slave select for the synchronous serial port.</p>
RA1/AN1 ⁽⁴⁾	3	3	28	I/O	TTL	
RA2/AN2 ⁽⁴⁾	4	4	1	I/O	TTL	
RA3/AN3/VREF ⁽⁴⁾	5	5	2	I/O	TTL	
RA4/T0CKI	6	6	3	I/O	ST	
RA5/SS/AN4 ⁽⁴⁾	7	7	4	I/O	TTL	
RB0/INT	21	21	18	I/O	TTL/ST ⁽¹⁾	<p>PORTB is a bidirectional I/O port. PORTB can be software programmed for internal weak pull-up on all inputs.</p> <p>RB0 can also be the external interrupt pin.</p> <p>Interrupt-on-change pin.</p> <p>Interrupt-on-change pin.</p> <p>Interrupt-on-change pin. Serial programming clock.</p> <p>Interrupt-on-change pin. Serial programming data.</p>
RB1	22	22	19	I/O	TTL	
RB2	23	23	20	I/O	TTL	
RB3	24	24	21	I/O	TTL	
RB4	25	25	22	I/O	TTL	
RB5	26	26	23	I/O	TTL	
RB6	27	27	24	I/O	TTL/ST ⁽²⁾	
RB7	28	28	25	I/O	TTL/ST ⁽²⁾	
RC0/T1OSO/T1CKI	11	11	8	I/O	ST	<p>PORTC is a bidirectional I/O port.</p> <p>RC0 can also be the Timer1 oscillator output or Timer1 clock input.</p> <p>RC1 can also be the Timer1 oscillator input or Capture2 input/Compare2 output/PWM2 output.</p> <p>RC2 can also be the Capture1 input/Compare1 output/PWM1 output.</p> <p>RC3 can also be the synchronous serial clock input/output for both SPI and I²C modes.</p> <p>RC4 can also be the SPI Data In (SPI mode) or data I/O (I²C mode).</p> <p>RC5 can also be the SPI Data Out (SPI mode).</p> <p>RC6 can also be the USART Asynchronous Transmit or Synchronous Clock.</p> <p>RC7 can also be the USART Asynchronous Receive or Synchronous Data.</p>
RC1/T1OSI/CCP2	12	12	9	I/O	ST	
RC2/CCP1	13	13	10	I/O	ST	
RC3/SCK/SCL	14	14	11	I/O	ST	
RC4/SDI/SDA	15	15	12	I/O	ST	
RC5/SDO	16	16	13	I/O	ST	
RC6/TX/CK	17	17	14	I/O	ST	
RC7/RX/DT	18	18	15	I/O	ST	
Vss	8, 19	8, 19	16	P	—	Ground reference for logic and I/O pins.
VDD	20	20	17	P	—	Positive supply for logic and I/O pins.

Legend: I = input O = output I/O = input/output P = power
 — = Not used TTL = TTL input ST = Schmitt Trigger input

- Note 1:** This buffer is a Schmitt Trigger input when configured as the external interrupt.
- 2:** This buffer is a Schmitt Trigger input when used in Serial Programming mode.
- 3:** This buffer is a Schmitt Trigger input when configured in RC Oscillator mode and a CMOS input otherwise.
- 4:** A/D module is not available in the PIC16C63A.

PIC16C63A/65B/73B/74B

FIGURE 3: 28-PIN QFN PACKAGE (DRAWING 1, PACKAGING)

28-Lead Plastic Quad Flat No Lead Package (ML) 6x6 mm Body, Punch Singulated (QFN)

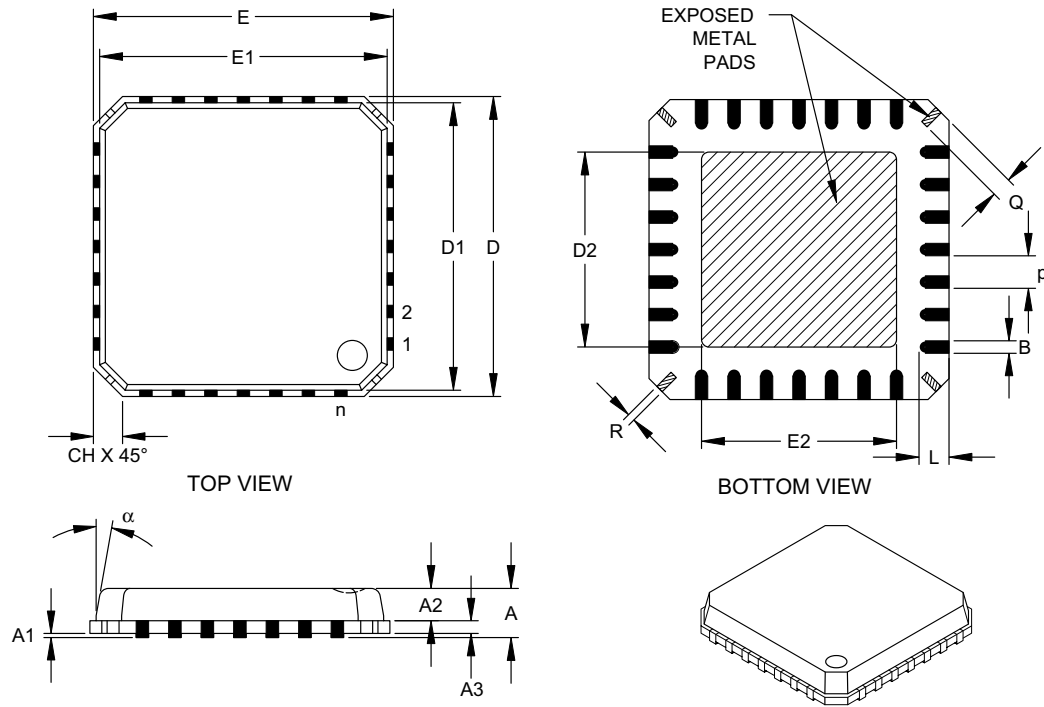

Dimension Limits	Units	INCHES			MILLIMETERS*		
		MIN	NOM	MAX	MIN	NOM	MAX
Number of Pins	n		28			28	
Pitch	p		.026 BSC			0.65 BSC	
Overall Height	A		.033	.039		0.85	1.00
Molded Package Thickness	A2		.026	.031		0.65	0.80
Standoff	A1	.000	.0004	.002	0.00	0.01	0.05
Base Thickness	A3		.008 REF			0.20 REF	
Overall Width	E		.236 BSC			6.00 BSC	
Molded Package Width	E1		.226 BSC			5.75 BSC	
Exposed Pad Width	E2	.140	.146	.152	3.55	3.70	3.85
Overall Length	D		.236 BSC			6.00 BSC	
Molded Package Length	D1		.226 BSC			5.75 BSC	
Exposed Pad Length	D2	.140	.146	.152	3.55	3.70	3.85
Lead Width	B	.009	.011	.014	0.23	0.28	0.35
Lead Length	L	.020	.024	.030	0.50	0.60	0.75
Tie Bar Width	R	.005	.007	.010	0.13	0.17	0.23
Tie Bar Length	Q	.012	.016	.026	0.30	0.40	0.65
Chamfer	CH	.009	.017	.024	0.24	0.42	0.60
Mold Draft Angle Top	α			12°			12°

*Controlling Parameter

Notes:

Dimensions D and E1 do not include mold flash or protrusions. Mold flash or protrusions shall not exceed .010" (0.254mm) per side.

JEDEC equivalent: mMO-220

Drawing No. C04-114

PIC16C63A/65B/73B/74B

FIGURE 4: 28-PIN QFN PACKAGE (DRAWING 2, PACKAGING)

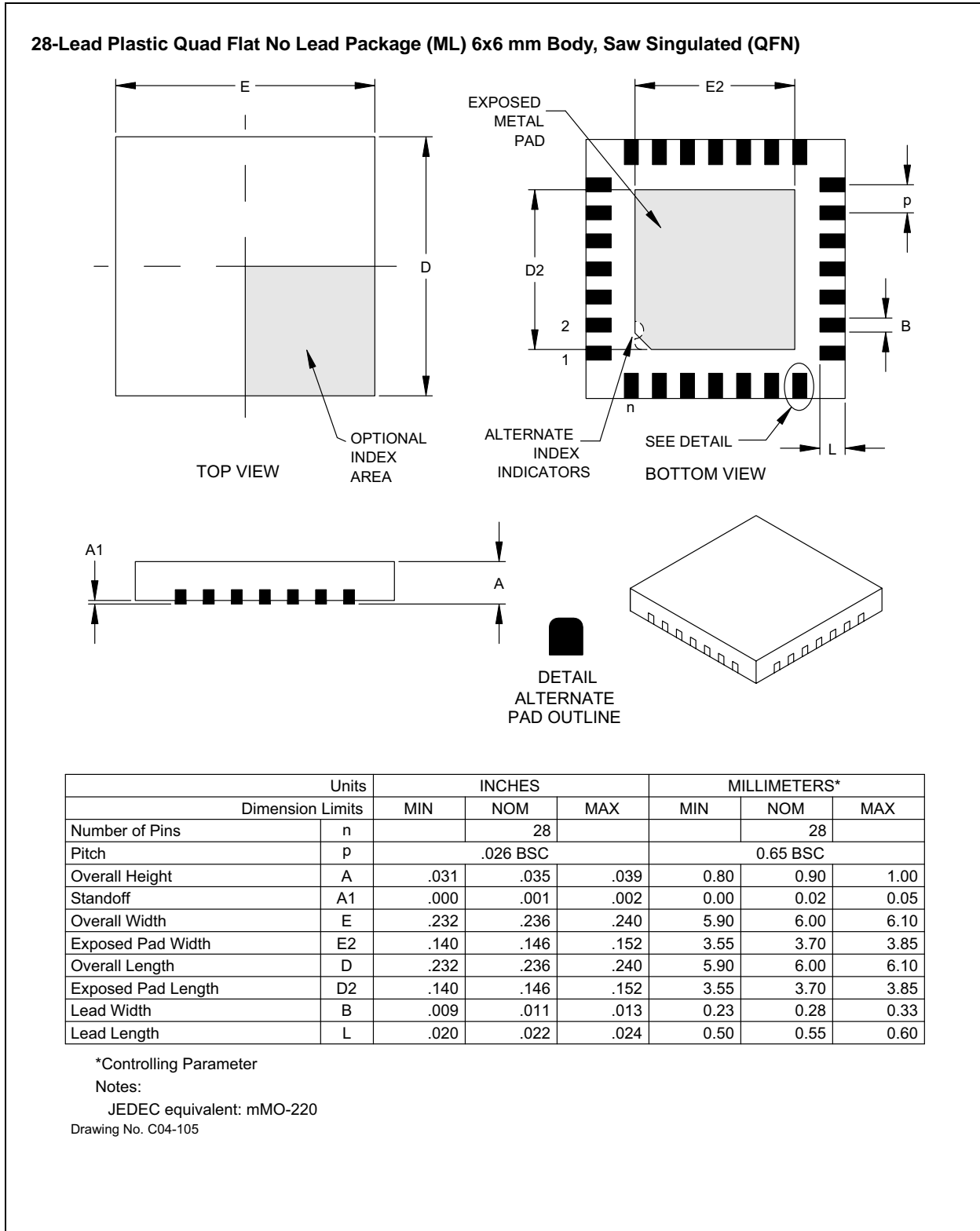

3. Module: RESET

Section 13.4.1 ("POWER-ON RESET (POR)") has been amended to clarify the minimum specifications required for $\overline{\text{MCLR}}$ in order to RESET the PIC16CXXX. The following paragraphs and figure have been added:

If a $\overline{\text{MCLR}}$ pulse occurs that is less than the minimum specification (parameter #30), improper device operation can occur.

If the minimum specification cannot be met, then an external circuit must be used to ensure that any pulse width less than the specification will be filtered before it reaches the $\overline{\text{MCLR}}$ pin.

A possible circuit to remedy this is shown in Figure 5. This circuit works by delaying the $\overline{\text{MCLR}}$ release following a power-up. If no delay is required, the capacitor may be omitted.

An alternative would be to use a supervisory circuit to control $\overline{\text{MCLR}}$.

Design validation should be performed to verify that the application works as expected.

FIGURE 5: $\overline{\text{MCLR}}$ EXTERNAL CIRCUIT

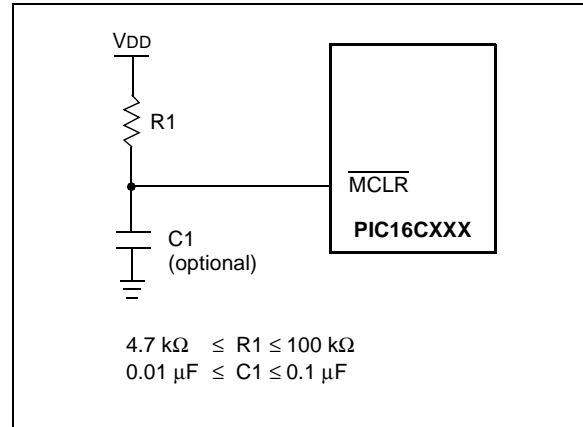

PIC16C63A/65B/73B/74B

REVISION HISTORY

Rev A Document (7/2003)

First revision of this document. Device Data Sheet Clarification issues 1 (SSP), 2 (Packaging) and 3 (RESET).

Note the following details of the code protection feature on Microchip devices:

- Microchip products meet the specification contained in their particular Microchip Data Sheet.
- Microchip believes that its family of products is one of the most secure families of its kind on the market today, when used in the intended manner and under normal conditions.
- There are dishonest and possibly illegal methods used to breach the code protection feature. All of these methods, to our knowledge, require using the Microchip products in a manner outside the operating specifications contained in Microchip's Data Sheets. Most likely, the person doing so is engaged in theft of intellectual property.
- Microchip is willing to work with the customer who is concerned about the integrity of their code.
- Neither Microchip nor any other semiconductor manufacturer can guarantee the security of their code. Code protection does not mean that we are guaranteeing the product as "unbreakable."

Code protection is constantly evolving. We at Microchip are committed to continuously improving the code protection features of our products. Attempts to break microchip's code protection feature may be a violation of the Digital Millennium Copyright Act. If such acts allow unauthorized access to your software or other copyrighted work, you may have a right to sue for relief under that Act.

Information contained in this publication regarding device applications and the like is intended through suggestion only and may be superseded by updates. It is your responsibility to ensure that your application meets with your specifications. No representation or warranty is given and no liability is assumed by Microchip Technology Incorporated with respect to the accuracy or use of such information, or infringement of patents or other intellectual property rights arising from such use or otherwise. Use of Microchip's products as critical components in life support systems is not authorized except with express written approval by Microchip. No licenses are conveyed, implicitly or otherwise, under any intellectual property rights.

Trademarks

The Microchip name and logo, the Microchip logo, dsPIC, KEELoQ, MPLAB, PIC, PICmicro, PICSTART, PRO MATE and PowerSmart are registered trademarks of Microchip Technology Incorporated in the U.S.A. and other countries.

FilterLab, microID, MXDEV, MXLAB, PICMASTER, SEEVAL and The Embedded Control Solutions Company are registered trademarks of Microchip Technology Incorporated in the U.S.A.

Accuron, Application Maestro, dsPICDEM, dsPICDEM.net, ECONOMONITOR, FanSense, FlexROM, fuzzyLAB, In-Circuit Serial Programming, ICSP, ICEPIC, microPort, Migratable Memory, MPASM, MPLIB, MPLINK, MPSIM, PICC, PICkit, PICDEM, PICDEM.net, PowerCal, PowerInfo, PowerMate, PowerTool, rLAB, rPIC, Select Mode, SmartSensor, SmartShunt, SmartTel and Total Endurance are trademarks of Microchip Technology Incorporated in the U.S.A. and other countries.

Serialized Quick Turn Programming (SQTP) is a service mark of Microchip Technology Incorporated in the U.S.A.

All other trademarks mentioned herein are property of their respective companies.

© 2003, Microchip Technology Incorporated, Printed in the U.S.A., All Rights Reserved.

 Printed on recycled paper.

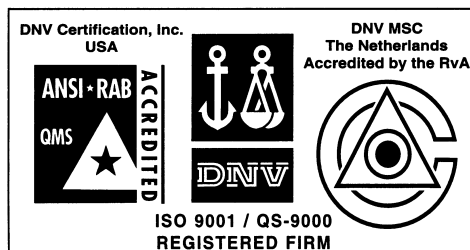

Microchip received QS-9000 quality system certification for its worldwide headquarters, design and wafer fabrication facilities in Chandler and Tempe, Arizona in July 1999 and Mountain View, California in March 2002. The Company's quality system processes and procedures are QS-9000 compliant for its PICmicro® 8-bit MCUs, KEELoQ® code hopping devices, Serial EEPROMs, microperipherals, non-volatile memory and analog products. In addition, Microchip's quality system for the design and manufacture of development systems is ISO 9001 certified.



WORLDWIDE SALES AND SERVICE

AMERICAS

Corporate Office

2355 West Chandler Blvd.
Chandler, AZ 85224-6199
Tel: 480-792-7200
Fax: 480-792-7277
Technical Support: 480-792-7627
Web Address: <http://www.microchip.com>

Atlanta

3780 Mansell Road, Suite 130
Alpharetta, GA 30022
Tel: 770-640-0034
Fax: 770-640-0307

Boston

2 Lan Drive, Suite 120
Westford, MA 01886
Tel: 978-692-3848
Fax: 978-692-3821

Chicago

333 Pierce Road, Suite 180
Itasca, IL 60143
Tel: 630-285-0071
Fax: 630-285-0075

Dallas

4570 Westgrove Drive, Suite 160
Addison, TX 75001
Tel: 972-818-7423
Fax: 972-818-2924

Detroit

Tri-Atria Office Building
32255 Northwestern Highway, Suite 190
Farmington Hills, MI 48334
Tel: 248-538-2250
Fax: 248-538-2260

Kokomo

2767 S. Albright Road
Kokomo, IN 46902
Tel: 765-864-8360
Fax: 765-864-8387

Los Angeles

18201 Von Karman, Suite 1090
Irvine, CA 92612
Tel: 949-263-1888
Fax: 949-263-1338

Phoenix

2355 West Chandler Blvd.
Chandler, AZ 85224-6199
Tel: 480-792-7966
Fax: 480-792-4338

San Jose

2107 North First Street, Suite 590
San Jose, CA 95131
Tel: 408-436-7950
Fax: 408-436-7955

Toronto

6285 Northam Drive, Suite 108
Mississauga, Ontario L4V 1X5, Canada
Tel: 905-673-0699
Fax: 905-673-6509

ASIA/PACIFIC

Australia

Suite 22, 41 Rawson Street
Epping 2121, NSW
Australia
Tel: 61-2-9868-6733
Fax: 61-2-9868-6755

China - Beijing

Unit 915
Bei Hai Wan Tai Bldg.
No. 6 Chaoyangmen Beidajie
Beijing, 100027, No. China
Tel: 86-10-85282100
Fax: 86-10-85282104

China - Chengdu

Rm. 2401-2402, 24th Floor,
Ming Xing Financial Tower
No. 88 TIDU Street
Chengdu 610016, China
Tel: 86-28-86766200
Fax: 86-28-86766599

China - Fuzhou

Unit 28F, World Trade Plaza
No. 71 Wusi Road
Fuzhou 350001, China
Tel: 86-591-7503506
Fax: 86-591-7503521

China - Hong Kong SAR

Unit 901-6, Tower 2, Metroplaza
223 Hing Fong Road
Kwai Fong, N.T., Hong Kong
Tel: 852-2401-1200
Fax: 852-2401-3431

China - Shanghai

Room 701, Bldg. B
Far East International Plaza
No. 317 Xian Xia Road
Shanghai, 200051
Tel: 86-21-6275-5700
Fax: 86-21-6275-5060

China - Shenzhen

Rm. 1812, 18/F, Building A, United Plaza
No. 5022 Binhe Road, Futian District
Shenzhen 518033, China
Tel: 86-755-82901380
Fax: 86-755-8295-1393

China - Shunde

Room 401, Hongjian Building
No. 2 Fengxiangnan Road, Ronggui Town
Shunde City, Guangdong 528303, China
Tel: 86-765-8395507 Fax: 86-765-8395571

China - Qingdao

Rm. B505A, Fullhope Plaza,
No. 12 Hong Kong Central Rd.
Qingdao 266071, China
Tel: 86-532-5027355 Fax: 86-532-5027205

India

Divyasree Chambers
1 Floor, Wing A (A3/A4)
No. 11, O'Shaughnessy Road
Bangalore, 560 025, India
Tel: 91-80-2290061 Fax: 91-80-2290062

Japan

Benex S-1 6F
3-18-20, Shinyokohama
Kohoku-Ku, Yokohama-shi
Kanagawa, 222-0033, Japan
Tel: 81-45-471-6166 Fax: 81-45-471-6122

Korea

168-1, Youngbo Bldg. 3 Floor
Samsung-Dong, Kangnam-Ku
Seoul, Korea 135-882
Tel: 82-2-554-7200 Fax: 82-2-558-5932 or
82-2-558-5934

Singapore

200 Middle Road
#07-02 Prime Centre
Singapore, 188980
Tel: 65-6334-8870 Fax: 65-6334-8850

Taiwan

Kaohsiung Branch
30F - 1 No. 8
Min Chuan 2nd Road
Kaohsiung 806, Taiwan
Tel: 886-7-536-4818
Fax: 886-7-536-4803

Taiwan

Taiwan Branch
11F-3, No. 207
Tung Hua North Road
Taipei, 105, Taiwan
Tel: 886-2-2717-7175 Fax: 886-2-2545-0139

EUROPE

Austria

Durisolstrasse 2
A-4600 Wels
Austria
Tel: 43-7242-2244-399
Fax: 43-7242-2244-393

Denmark

Regus Business Centre
Lautrup høj 1-3
Ballerup DK-2750 Denmark
Tel: 45-4420-9895 Fax: 45-4420-9910

France

Parc d'Activite du Moulin de Massy
43 Rue du Saule Trapu
Batiment A - 1er Etage
91300 Massy, France
Tel: 33-1-69-53-63-20
Fax: 33-1-69-30-90-79

Germany

Steinheilstrasse 10
D-85737 Ismaning, Germany
Tel: 49-89-627-144-0
Fax: 49-89-627-144-44

Italy

Via Quasimodo, 12
20025 Legnano (MI)
Milan, Italy
Tel: 39-0331-742611
Fax: 39-0331-466781

Netherlands

P. A. De Biesbosch 14
NL-5152 SC Drunen, Netherlands
Tel: 31-416-690399
Fax: 31-416-690340

United Kingdom

505 Eskdale Road
Winnersh Triangle
Wokingham
Berkshire, England RG41 5TU
Tel: 44-118-921-5869
Fax: 44-118-921-5820

07/28/03