

SN75476 THRU SN75478 DUAL PERIPHERAL DRIVERS

SLRS025A – DECEMBER 1976 – REVISED NOVEMBER 1995

- Characterized for Use to 300 mA
- No Output Latch-Up at 55 V (After Conducting 300 mA)
- High-Voltage Outputs (100 V Typ)
- Output Clamp Diodes for Transient Suppression (300 mA, 70 V)
- TTL- or MOS-Compatible Diode-Clamped Inputs
- pnp Transistor Inputs Reduce Input Current
- Standard Supply Voltage
- Suitable for Hammer-Driver Applications
- Plastic DIP (P) With Copper-Lead Frame Provides Cooler Operation and Improved Reliability

description

The SN75476 through SN75478 are dual peripheral drivers designed for use in systems that require high current, high voltage, and fast switching times. The SN75476, SN75477, and SN75478 provide AND, NAND, and OR drivers respectively. These devices have diode-clamped inputs as well as high-current, high-voltage clamp diodes on the outputs for inductive transient protection.

The SN75476, SN75477, and SN75478 drivers are characterized for operation from 0°C to 70°C.

schematics of inputs and outputs

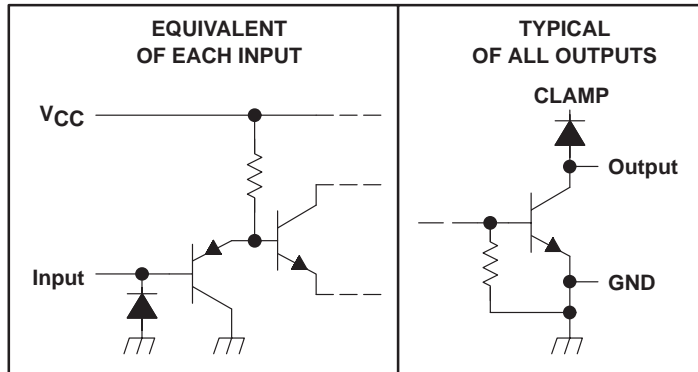

D OR P PACKAGE
(TOP VIEW)

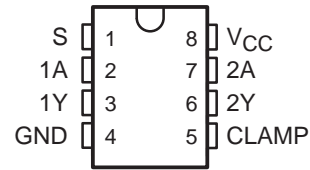

Function Tables

SN75476
(each AND driver)

INPUTS		OUTPUT
A	S	Y
H	H	H
L	X	L
X	L	L

SN75477
(each NAND driver)

INPUTS		OUTPUT
A	S	Y
H	H	L
L	X	H
X	L	H

SN75478
(each OR driver)

INPUTS		OUTPUT
A	S	Y
H	X	H
X	H	H
L	L	L

H = high level, L = low level
X = irrelevant

PRODUCTION DATA information is current as of publication date. Products conform to specifications per the terms of Texas Instruments standard warranty. Production processing does not necessarily include testing of all parameters.



Copyright © 1995, Texas Instruments Incorporated

SN75476 THRU SN75478 DUAL PERIPHERAL DRIVERS

SLRS025A – DECEMBER 1976 – REVISED NOVEMBER 1995

logic symbols†

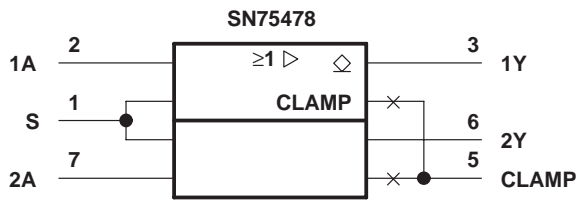
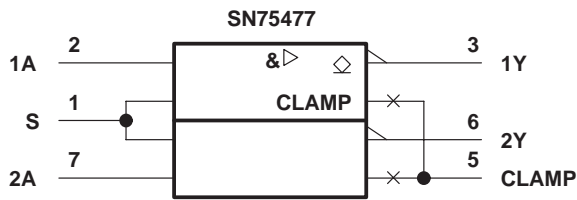
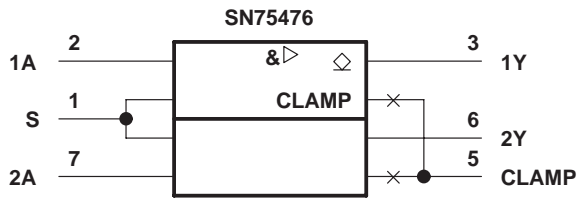

logic diagrams (positive logic)

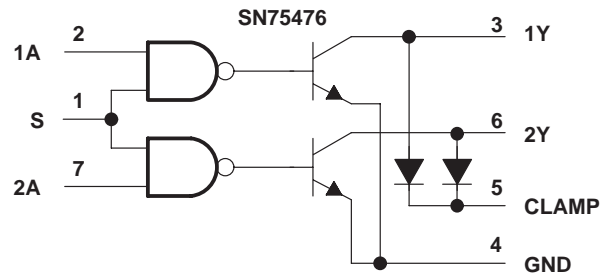

Positive Logic: $Y = AS$ or $\overline{A+S}$

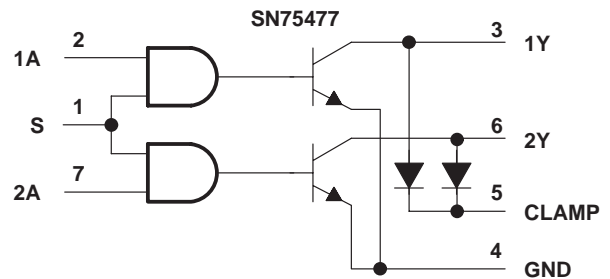

Positive Logic: $Y = \overline{AS}$ or $\overline{A+S}$

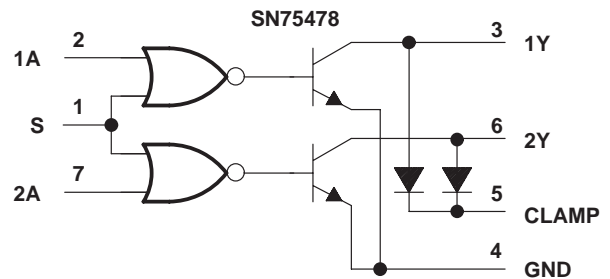

Positive Logic: $Y = A+S$ or $\overline{\overline{A} \overline{S}}$

† These symbols are in accordance with ANSI/IEEE Std 91-1984 and IEC publication 617-12.

SN75476 THRU SN75478 DUAL PERIPHERAL DRIVERS

SLRS025A – DECEMBER 1976 – REVISED NOVEMBER 1995

absolute maximum ratings over operating free-air temperature range (unless otherwise noted)

Supply voltage, V_{CC} (see Note 1)	7 V
Input voltage, V_I	5.5 V
Continuous output current (see Note 2)	400 mA
Peak output current: $t_w \leq 10$ ms, duty cycle $\leq 50\%$	500 mA
$t_w \leq 30$ ns, duty cycle $\leq 0.002\%$	3 A
Output clamp current, I_{OK}	400 mA
Continuous total power dissipation	See Dissipation Rating Table
Operating free-air temperature range, T_A	0°C to 70°C
Storage temperature range, T_{stg}	-65°C to 150°C
Lead temperature 1,6 mm (1/16 inch) from case for 10 seconds	260°C

- NOTES: 1. Voltage values are with respect to network GND.
2. Both halves of this dual circuit may conduct rated current simultaneously; however, power dissipation averaged over a short time interval must fall within the continuous power dissipation ratings.

DISSIPATION RATING TABLE

PACKAGE	$T_A \leq 25^\circ\text{C}$ POWER RATING	DERATING FACTOR ABOVE $T_A = 25^\circ\text{C}$	$T_A = 70^\circ\text{C}$ POWER RATING
D	725 mW	5.8 mW/°C	464 mW
P	1000 mW	8.0 mW/°C	640 mW

recommended operating conditions

	MIN	NOM	MAX	UNIT
Supply voltage, V_{CC}	4.5	5	5.5	V
High-level input voltage, V_{IH}	2			V
Low-level input voltage, V_{IL}			0.8	V
Operating free-air temperature, T_A	0		70	°C



SN75476 THRU SN75478 DUAL PERIPHERAL DRIVERS

SLRS025A – DECEMBER 1976 – REVISED NOVEMBER 1995

electrical characteristics over recommended operating free-air temperature range

PARAMETER		TEST CONDITIONS		MIN	TYP†	MAX	UNIT
V_{IK}	Input clamp voltage	$I_I = -12 \text{ mA}$		-0.95	-1.5		V
V_{OL}	Low-level output voltage	$V_{CC} = 4.5 \text{ V},$ $V_{IH} = 2 \text{ V},$ $V_{IL} = 0.8 \text{ V}$	$I_{OL} = 100 \text{ mA}$	0.16	0.3		V
			$I_{OL} = 175 \text{ mA}$	0.22	0.5		
			$I_{OL} = 300 \text{ mA}$	0.33	0.6		
$V_{O(BR)}$	Output breakdown voltage	$V_{CC} = 4.5 \text{ V},$	$I_{OH} = 100 \mu\text{A}$	70	100		V
$V_{R(K)}$	Output clamp reverse voltage	$V_{CC} = 4.5 \text{ V},$	$I_R = 100 \mu\text{A}$	70	100		V
$V_{F(K)}$	Output clamp forward voltage	$V_{CC} = 4.5 \text{ V},$	$I_F = 300 \text{ mA}$	0.8	1.15	1.6	V
I_{OH}	High-level output current	$V_{CC} = 4.5 \text{ V},$ $V_{IL} = 0.8 \text{ V},$	$V_{IH} = 2 \text{ V},$ $V_{OH} = 70 \text{ V}$		1	100	μA
I_{IH}	High-level input current	$V_{CC} = 5.5 \text{ V},$	$V_I = 5.5 \text{ V}$		0.01	10	μA
I_{IL}	Low-level input current	A input	$V_{CC} = 5.5 \text{ V},$ $V_I = 0.8 \text{ V}$		-80	-110	μA
		S input			-160	-220	
I_{CCH}	Supply current, outputs high	SN75476	$V_{CC} = 5.5 \text{ V}$	$V_I = 5 \text{ V}$	10	17	mA
		SN75477		$V_I = 0$	10	17	
		SN75478		$V_I = 5 \text{ V}$	10	17	
I_{CCL}	Supply current, outputs low	SN75476	$V_{CC} = 5.5 \text{ V}$	$V_I = 0$	54	75	mA
		SN75477		$V_I = 5 \text{ V}$	54	75	
		SN75478		$V_I = 0$	54	75	

† All typical values are at $V_{CC} = 5 \text{ V}, T_A = 25^\circ\text{C}$.

switching characteristics, $V_{CC} = 5 \text{ V}, T_A = 25^\circ\text{C}$

PARAMETER		TEST CONDITIONS		MIN	TYP	MAX	UNIT
t_{PLH}	Propagation delay time, low-to-high-level output	$C_L = 15 \text{ pF},$ $R_L = 100 \Omega,$ See Figure 1			200	350	ns
t_{PHL}	Propagation delay time, high-to-low-level output				200	350	ns
t_{TLH}	Transition time, low-to-high-level output				50	125	ns
t_{THL}	Transition time, high-to-low-level output				90	125	ns
V_{OH}	High-level output voltage after switching	$V_S = 55 \text{ V},$ See Figure 2	$I_O \approx 300 \text{ mA},$	$V_S - 18$			mV



PARAMETER MEASUREMENT INFORMATION

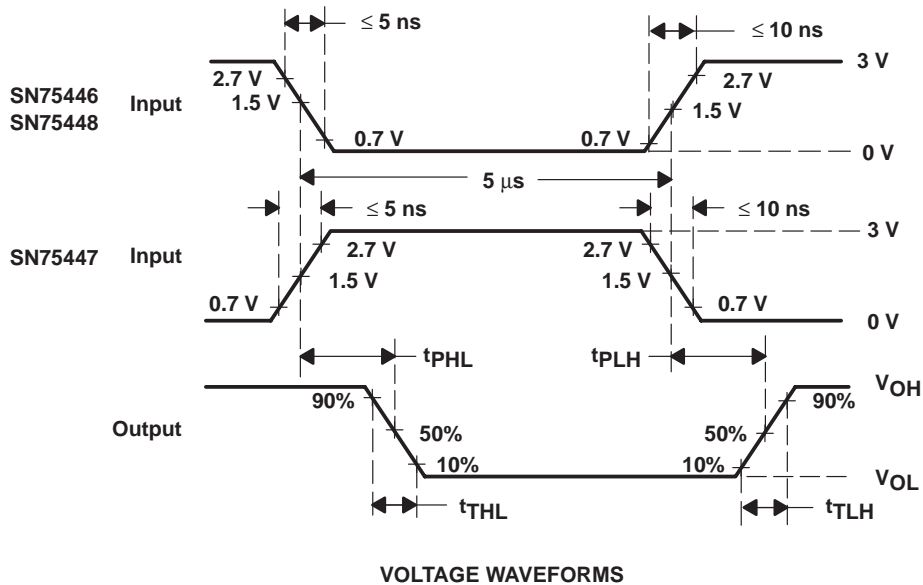
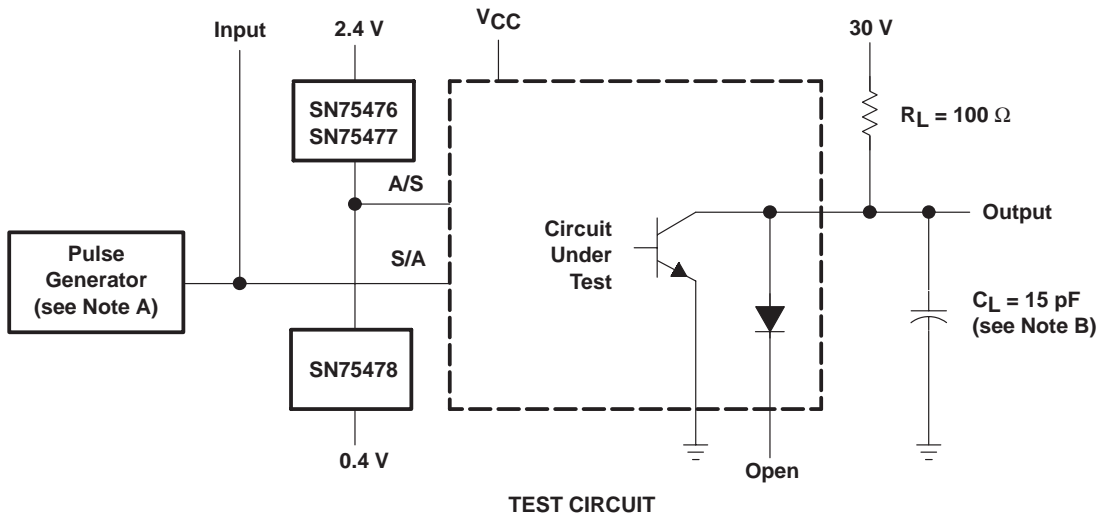

- NOTES: A. The pulse generator has the following characteristics: PRR = 100 kHz, $Z_O = 50 \Omega$.
 B. C_L includes probe and jig capacitance.

Figure 1. Test Circuit and Voltage Waveforms, Switching Characteristics

SN75476 THRU SN75478 DUAL PERIPHERAL DRIVERS

SLRS025A – DECEMBER 1976 – REVISED NOVEMBER 1995

PARAMETER MEASUREMENT INFORMATION

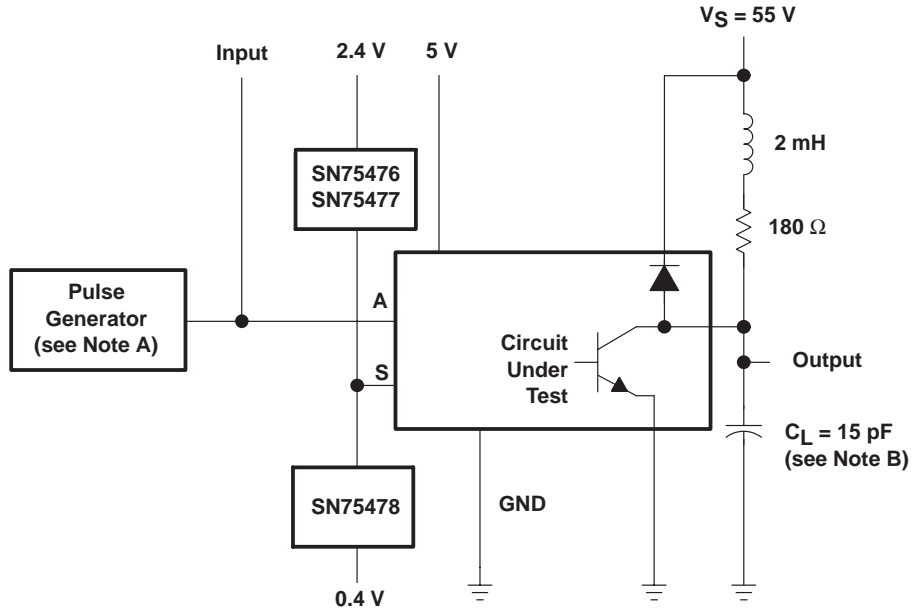

TEST CIRCUIT

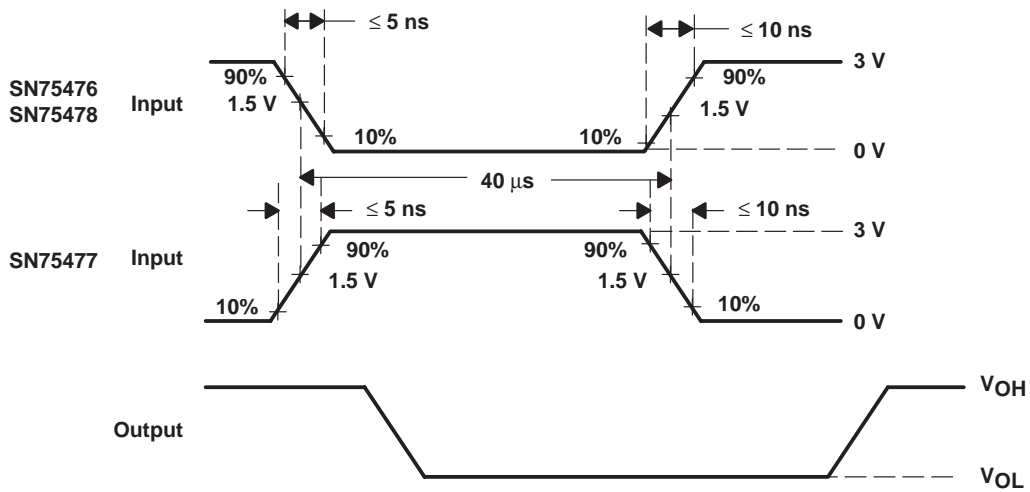

VOLTAGE WAVEFORMS

- NOTES: A. The pulse generator has the following characteristics: PRR = 12.5 kHz, $Z_0 = 50 \Omega$.
 B. C_L includes probe and jig capacitance.

Figure 2. Latch-Up Test Circuit and Voltage Waveforms

PACKAGING INFORMATION

Orderable Device	Status ⁽¹⁾	Package Type	Package Drawing	Pins	Package Qty	Eco Plan ⁽²⁾	Lead/Ball Finish	MSL Peak Temp ⁽³⁾
SN75476D	OBSOLETE	SOIC	D	8		TBD	Call TI	Call TI
SN75476DR	OBSOLETE	SOIC	D	8		TBD	Call TI	Call TI
SN75476P	OBSOLETE	PDIP	P	8		TBD	Call TI	Call TI
SN75477D	ACTIVE	SOIC	D	8	75	Green (RoHS & no Sb/Br)	CU NIPDAU	Level-1-260C-UNLIM
SN75477DE4	ACTIVE	SOIC	D	8	75	Green (RoHS & no Sb/Br)	CU NIPDAU	Level-1-260C-UNLIM
SN75477DR	ACTIVE	SOIC	D	8	2500	Green (RoHS & no Sb/Br)	CU NIPDAU	Level-1-260C-UNLIM
SN75477DRE4	ACTIVE	SOIC	D	8	2500	Green (RoHS & no Sb/Br)	CU NIPDAU	Level-1-260C-UNLIM
SN75477P	ACTIVE	PDIP	P	8	50	Pb-Free (RoHS)	CU NIPDAU	N / A for Pkg Type
SN75477PE4	ACTIVE	PDIP	P	8	50	Pb-Free (RoHS)	CU NIPDAU	N / A for Pkg Type
SN75478D	OBSOLETE	SOIC	D	8		TBD	Call TI	Call TI
SN75478P	ACTIVE	PDIP	P	8	50	Pb-Free (RoHS)	CU NIPDAU	N / A for Pkg Type
SN75478PE4	ACTIVE	PDIP	P	8	50	Pb-Free (RoHS)	CU NIPDAU	N / A for Pkg Type

⁽¹⁾ The marketing status values are defined as follows:

ACTIVE: Product device recommended for new designs.

LIFEBUY: TI has announced that the device will be discontinued, and a lifetime-buy period is in effect.

NRND: Not recommended for new designs. Device is in production to support existing customers, but TI does not recommend using this part in a new design.

PREVIEW: Device has been announced but is not in production. Samples may or may not be available.

OBSOLETE: TI has discontinued the production of the device.

⁽²⁾ Eco Plan - The planned eco-friendly classification: Pb-Free (RoHS), Pb-Free (RoHS Exempt), or Green (RoHS & no Sb/Br) - please check <http://www.ti.com/productcontent> for the latest availability information and additional product content details.

TBD: The Pb-Free/Green conversion plan has not been defined.

Pb-Free (RoHS): TI's terms "Lead-Free" or "Pb-Free" mean semiconductor products that are compatible with the current RoHS requirements for all 6 substances, including the requirement that lead not exceed 0.1% by weight in homogeneous materials. Where designed to be soldered at high temperatures, TI Pb-Free products are suitable for use in specified lead-free processes.

Pb-Free (RoHS Exempt): This component has a RoHS exemption for either 1) lead-based flip-chip solder bumps used between the die and package, or 2) lead-based die adhesive used between the die and leadframe. The component is otherwise considered Pb-Free (RoHS compatible) as defined above.

Green (RoHS & no Sb/Br): TI defines "Green" to mean Pb-Free (RoHS compatible), and free of Bromine (Br) and Antimony (Sb) based flame retardants (Br or Sb do not exceed 0.1% by weight in homogeneous material)

⁽³⁾ MSL, Peak Temp. -- The Moisture Sensitivity Level rating according to the JEDEC industry standard classifications, and peak solder temperature.

Important Information and Disclaimer: The information provided on this page represents TI's knowledge and belief as of the date that it is provided. TI bases its knowledge and belief on information provided by third parties, and makes no representation or warranty as to the accuracy of such information. Efforts are underway to better integrate information from third parties. TI has taken and continues to take reasonable steps to provide representative and accurate information but may not have conducted destructive testing or chemical analysis on incoming materials and chemicals. TI and TI suppliers consider certain information to be proprietary, and thus CAS numbers and other limited information may not be available for release.

In no event shall TI's liability arising out of such information exceed the total purchase price of the TI part(s) at issue in this document sold by TI to Customer on an annual basis.

P (R-PDIP-T8)

PLASTIC DUAL-IN-LINE

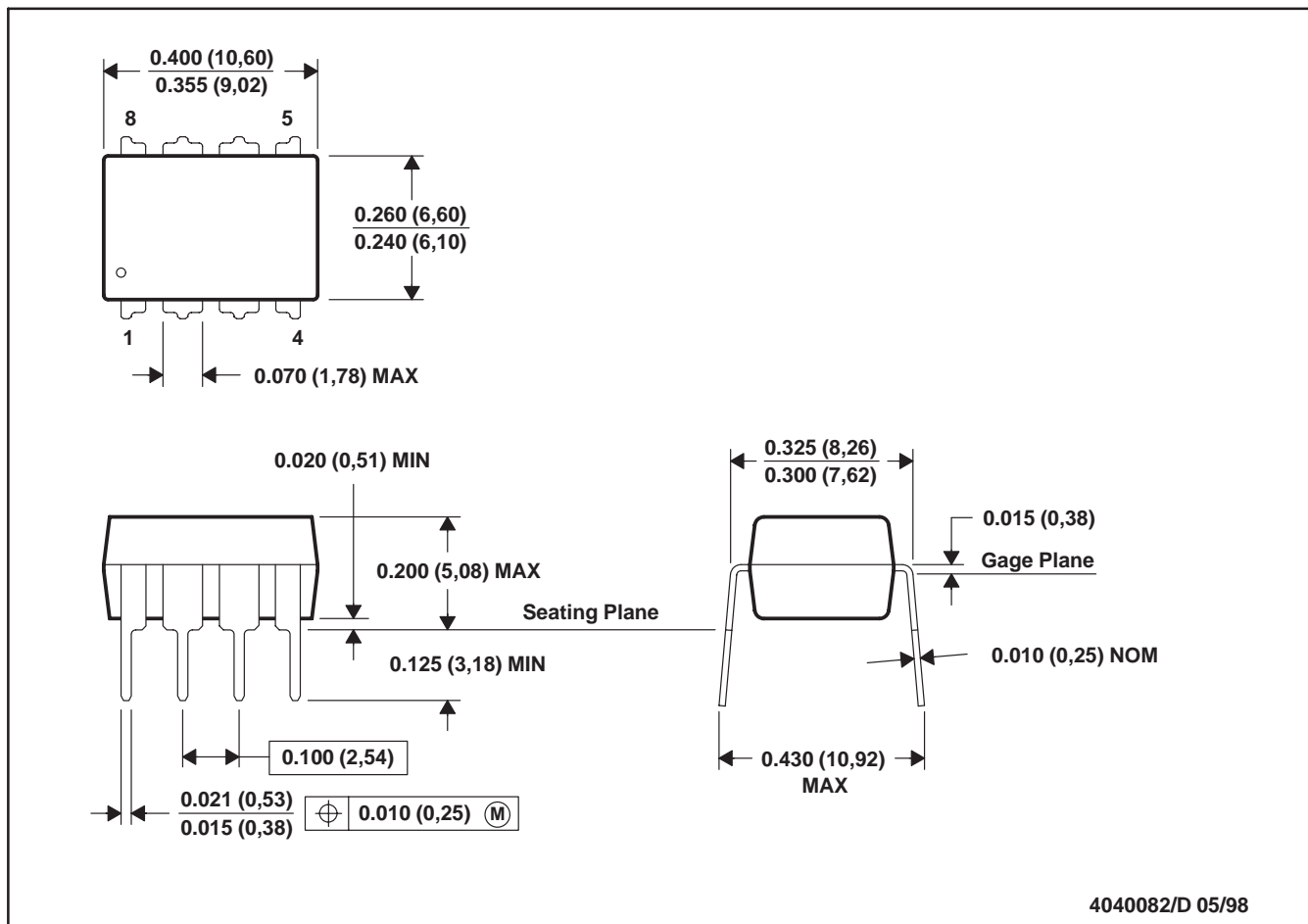

- NOTES: A. All linear dimensions are in inches (millimeters).
 B. This drawing is subject to change without notice.
 C. Falls within JEDEC MS-001

For the latest package information, go to http://www.ti.com/sc/docs/package/pkg_info.htm



D (R-PDSO-G8)

PLASTIC SMALL-OUTLINE PACKAGE

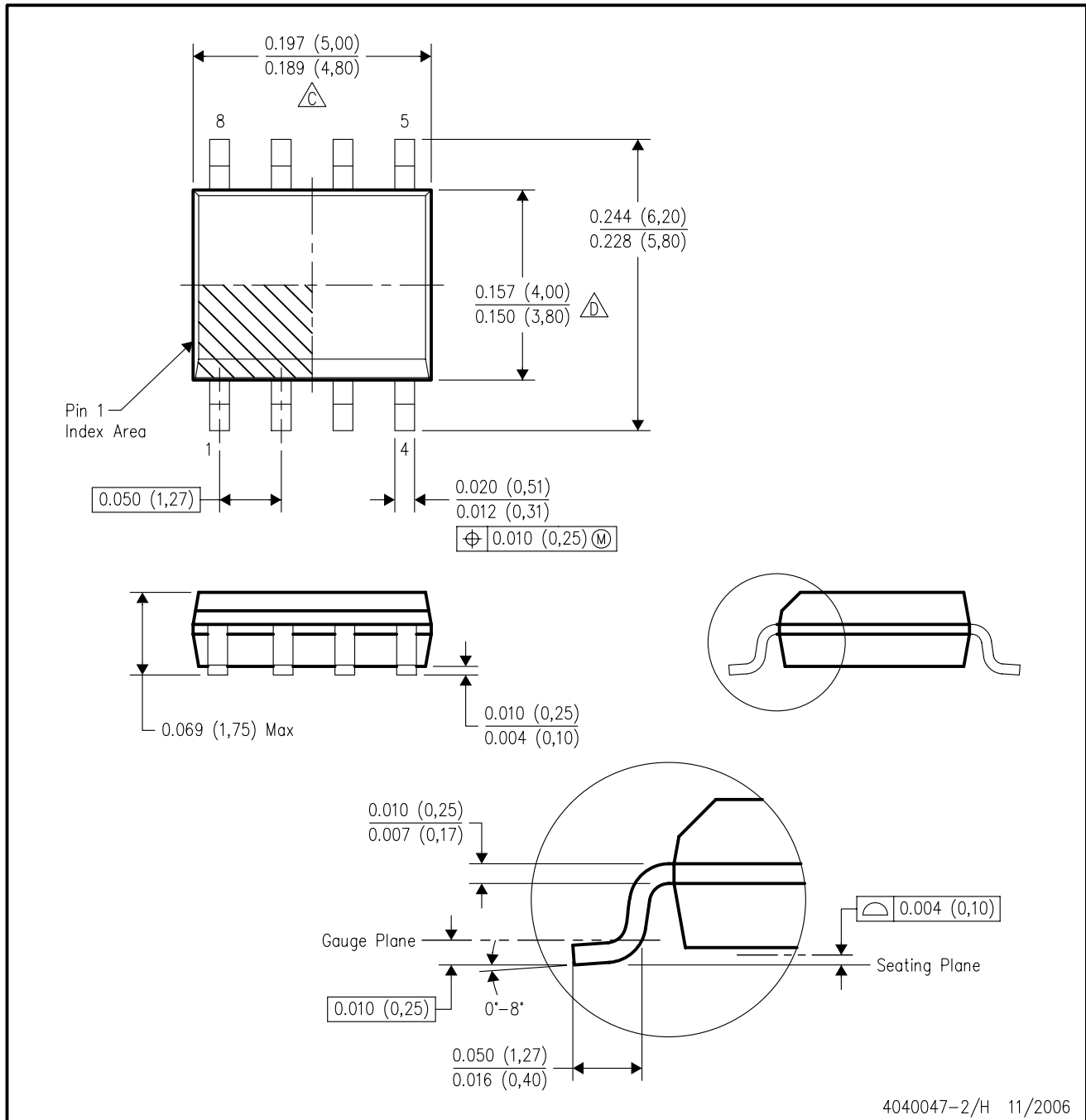

- NOTES:
- A. All linear dimensions are in inches (millimeters).
 - B. This drawing is subject to change without notice.
 - C. Body length does not include mold flash, protrusions, or gate burrs. Mold flash, protrusions, or gate burrs shall not exceed .006 (0,15) per end.
 - D. Body width does not include interlead flash. Interlead flash shall not exceed .017 (0,43) per side.
 - E. Reference JEDEC MS-012 variation AA.

IMPORTANT NOTICE

Texas Instruments Incorporated and its subsidiaries (TI) reserve the right to make corrections, modifications, enhancements, improvements, and other changes to its products and services at any time and to discontinue any product or service without notice. Customers should obtain the latest relevant information before placing orders and should verify that such information is current and complete. All products are sold subject to TI's terms and conditions of sale supplied at the time of order acknowledgment.

TI warrants performance of its hardware products to the specifications applicable at the time of sale in accordance with TI's standard warranty. Testing and other quality control techniques are used to the extent TI deems necessary to support this warranty. Except where mandated by government requirements, testing of all parameters of each product is not necessarily performed.

TI assumes no liability for applications assistance or customer product design. Customers are responsible for their products and applications using TI components. To minimize the risks associated with customer products and applications, customers should provide adequate design and operating safeguards.

TI does not warrant or represent that any license, either express or implied, is granted under any TI patent right, copyright, mask work right, or other TI intellectual property right relating to any combination, machine, or process in which TI products or services are used. Information published by TI regarding third-party products or services does not constitute a license from TI to use such products or services or a warranty or endorsement thereof. Use of such information may require a license from a third party under the patents or other intellectual property of the third party, or a license from TI under the patents or other intellectual property of TI.

Reproduction of information in TI data books or data sheets is permissible only if reproduction is without alteration and is accompanied by all associated warranties, conditions, limitations, and notices. Reproduction of this information with alteration is an unfair and deceptive business practice. TI is not responsible or liable for such altered documentation.

Resale of TI products or services with statements different from or beyond the parameters stated by TI for that product or service voids all express and any implied warranties for the associated TI product or service and is an unfair and deceptive business practice. TI is not responsible or liable for any such statements.

Following are URLs where you can obtain information on other Texas Instruments products and application solutions:

Products		Applications	
Amplifiers	amplifier.ti.com	Audio	www.ti.com/audio
Data Converters	dataconverter.ti.com	Automotive	www.ti.com/automotive
DSP	dsp.ti.com	Broadband	www.ti.com/broadband
Interface	interface.ti.com	Digital Control	www.ti.com/digitalcontrol
Logic	logic.ti.com	Military	www.ti.com/military
Power Mgmt	power.ti.com	Optical Networking	www.ti.com/opticalnetwork
Microcontrollers	microcontroller.ti.com	Security	www.ti.com/security
Low Power Wireless	www.ti.com/lpw	Telephony	www.ti.com/telephony
		Video & Imaging	www.ti.com/video
		Wireless	www.ti.com/wireless

Mailing Address: Texas Instruments
Post Office Box 655303 Dallas, Texas 75265