

SN75471 THRU SN75473 DUAL PERIPHERAL DRIVERS

SLRS024 – DECEMBER 1976 – REVISED MAY 1990

PERIPHERAL DRIVERS FOR HIGH-VOLTAGE HIGH-CURRENT DRIVER APPLICATIONS

- Characterized for Use to 300 mA
- High-Voltage Outputs
- No Output Latch-Up at 55 V (After Conducting 300 mA)
- Medium-Speed Switching
- Circuit Flexibility for Varied Applications and Choice of Logic Function
- TTL-Compatible Diode-Clamped Inputs
- Standard Supply Voltages
- Plastic DIP (P) With Copper Lead Frame Provides Cooler Operation and Improved Reliability

D OR P PACKAGE (TOP VIEW)

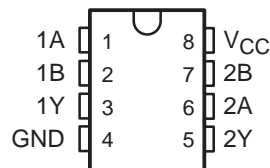

SUMMARY OF SERIES SN75471

DEVICE	LOGIC OF COMPLETE CIRCUIT	PACKAGES
SN75471	AND	D, P
SN75472	NAND	D, P
SN75473	OR	D, P

description

Series SN75471 dual peripheral drivers are functionally interchangeable with series SN75451B and series SN75461 peripheral drivers, but are designed for use in systems that require higher breakdown voltages than either of those series can provide at the expense of slightly slower switching speeds than series 75451B (limits are the same as series SN75461). Typical applications include high-speed logic buffers, power drivers, relay drivers, lamp drivers, MOS drivers, line drivers, and memory drivers.

The SN75471, SN75472, and SN75473 are dual peripheral AND, NAND, and OR drivers, respectively, (assuming positive logic), with the output of the logic gates internally connected to the bases of the npn output transistors.

Series SN75471 drivers are characterized for operation from 0°C to 70°C.

SN75471 THRU SN75473 DUAL PERIPHERAL DRIVERS

SLRS024 – DECEMBER 1976 – REVISED MAY 1990

absolute maximum ratings over operating free-air temperature range (unless otherwise noted)

Supply voltage, V_{CC} (see Note 1)	7 V
Input voltage, V_I	5.5 V
Inter-emitter voltage (see Note 2)	5.5 V
Off-state output voltage, V_O	70 V
Continuous collector or output current (see Note 3)	400 mA
Peak collector or output current ($t_w \leq 10$ ms, duty cycle $\leq 50\%$, see Note 3)	500 mA
Continuous total power dissipation	See Dissipation Rating Table
Operating free-air temperature range, T_A	0°C to 70°C
Storage temperature range, T_{stg}	-65°C to 150°C
Lead temperature 1,6 mm (1/16 inch) from case for 10 seconds	260°C

- NOTES: 1. Voltage values are with respect to the network GND, unless otherwise specified.
 2. This is the voltage between two emitters, A and B.
 3. Both halves of these dual circuits may conduct rated current simultaneously; however, power dissipation averaged over a short time interval must fall within the continuous dissipation rating.

DISSIPATION RATING TABLE

PACKAGE	$T_A \leq 25^\circ\text{C}$ POWER RATING	DERATING FACTOR ABOVE $T_A = 25^\circ\text{C}$	$T_A = 70^\circ\text{C}$ POWER RATING
D	725 mW	5.8 mW/°C	464 mW
P	1000 mW	8.0 mW/°C	640 mW

recommended operating conditions

	MIN	NOM	MAX	UNIT
Supply voltage, V_{CC}	4.75	5	5.25	V
High-level input voltage, V_{IH}	2			V
Low-level input voltage, V_{IL}			0.8	V
Operating free-air temperature, T_A	0		70	°C



SN75471 THRU SN75473 DUAL PERIPHERAL DRIVERS

SLRS024 – DECEMBER 1976 – REVISED MAY 1990

logic symbol†



† This symbol is in accordance with ANSI/IEEE Std 91-1984 and IEC Publication 617-12.

logic diagram (positive logic)

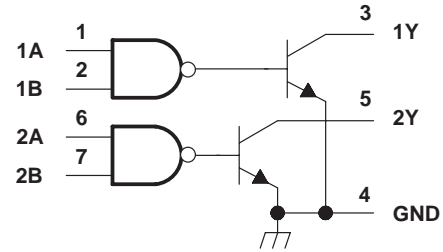

SN75471 FUNCTION TABLE
(each driver)

A	B	Y
L	L	L (on state)
L	H	L (on state)
H	L	L (on state)
H	H	H (off state)

positive logic:
 $Y = AB$ or $\bar{A} + \bar{B}$

SN75471 schematic (each driver)

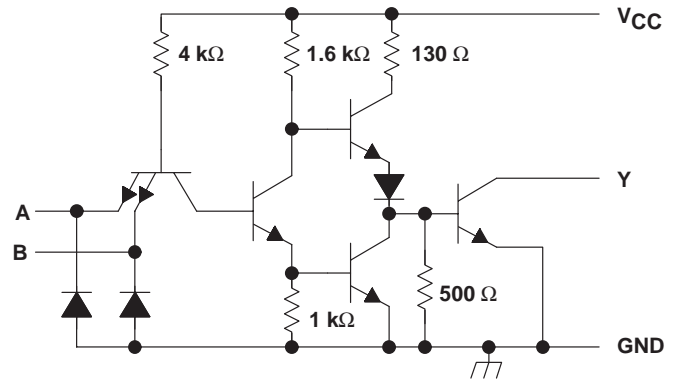

Resistor values shown are nominal.

electrical characteristics over recommended operating free-air temperature range

PARAMETER	TEST CONDITIONS	SN75471			UNIT
		MIN	TYP‡	MAX	
V_{IK} Input clamp voltage	$V_{CC} = 4.75$ V, $I_I = -12$ mA	-1.2	-1.5		V
I_{OH} High-level output current	$V_{CC} = 4.75$ V, $V_{IH} = 2$ V, $V_{OH} = 70$ V			100	μ A
V_{OL} Low-level output voltage	$V_{CC} = 4.75$ V, $V_{IL} = 0.8$ V, $I_{OL} = 100$ mA		0.25	0.4	V
	$V_{CC} = 4.75$ V, $V_{IL} = 0.8$ V, $I_{OL} = 300$ mA		0.5	0.7	
I_I Input current at maximum input voltage	$V_{CC} = 5.25$ V, $V_I = 5.5$ V			1	mA
I_{IH} High-level input current	$V_{CC} = 5.25$ V, $V_I = 2.4$ V			40	μ A
I_{IL} Low-level input current	$V_{CC} = 5.25$ V, $V_I = 0.4$ V		-1	-1.6	mA
I_{CCH} Supply current, outputs high	$V_{CC} = 5.25$ V, $V_I = 5$ V		7	11	mA
I_{CCL} Supply current, outputs low	$V_{CC} = 5.25$ V, $V_I = 0$		52	65	mA

‡ All typical values are at $V_{CC} = 5$ V, $T_A = 25^\circ\text{C}$.

switching characteristics, $V_{CC} = 5$ V, $T_A = 25^\circ\text{C}$

PARAMETER	TEST CONDITIONS	SN75471			UNIT
		MIN	TYP	MAX	
t_{PLH} Propagation delay time, low-to-high-level output	$I_O \approx 200$ mA, $C_L = 15$ pF, $R_L = 50$ Ω , See Figure 1		30	55	ns
t_{PHL} Propagation delay time, high-to-low-level output			25	40	
t_{TLH} Transition time, low-to-high-level output			8	20	
t_{THL} Transition time, high-to-low-level output			10	20	
V_{OH} High-level output voltage after switching	$V_S = 55$ V, See Figure 2, $I_O \approx 300$ mA,	$V_S - 18$			mV

SN75471 THRU SN75473 DUAL PERIPHERAL DRIVERS

SLRS024 – DECEMBER 1976 – REVISED MAY 1990

logic symbol†



† This symbol is in accordance with ANSI/IEEE Std 91-1984 and IEC Publication 617-12.

logic diagram (positive logic)

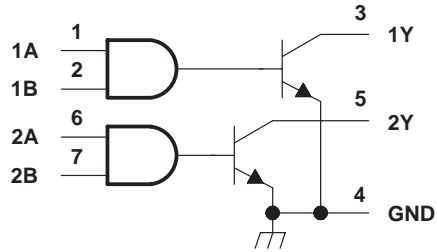

SN75472 FUNCTION TABLE
(each driver)

A	B	Y
L	L	H (off state)
L	H	H (off state)
H	L	H (off state)
H	H	L (on state)

positive logic:
 $Y = \overline{AB}$ or $\overline{A + B}$

SN75472 schematic (each driver)

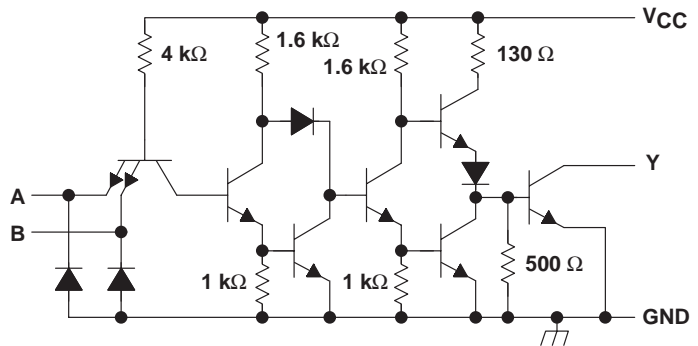

Resistor values shown are nominal.

electrical characteristics over recommended operating free-air temperature range

PARAMETER	TEST CONDITIONS	SN75472			UNIT	
		MIN	TYP‡	MAX		
V _{IK} Input clamp voltage	V _{CC} = 4.75 V, I _I = -12 mA	-1.2	-1.5		V	
I _{OH} High-level output current	V _{CC} = 4.75 V, V _{IH} = 2 V, V _{OH} = 70 V			100	μA	
V _{OL} Low-level output voltage	V _{CC} = 4.75 V, V _{IL} = 0.8 V, I _{OL} = 100 mA	0.25		0.4	V	
	V _{CC} = 4.75 V, V _{IL} = 0.8 V, I _{OL} = 300 mA	0.5		0.7		
I _I Input current at maximum input voltage	V _{CC} = 5.25 V, V _I = 5.5 V			1	mA	
I _{IH} High-level input current	V _{CC} = 5.25 V, V _I = 2.4 V			40	μA	
I _{IL} Low-level input current	V _{CC} = 5.25 V, V _I = 0.4 V			-1	-1.6	mA
I _{CCH} Supply current, outputs high	V _{CC} = 5.25 V, V _I = 5 V			13	17	mA
I _{CCL} Supply current, outputs low	V _{CC} = 5.25 V, V _I = 0			61	76	mA

‡ All typical values are at V_{CC} = 5 V, T_A = 25°C.

switching characteristics, V_{CC} = 5 V, T_A = 25°C

PARAMETER	TEST CONDITIONS	SN75472			UNIT
		MIN	TYP	MAX	
t _{PLH} Propagation delay time, low-to-high-level output	I _O ≈ 200 mA, C _L = 15 pF, R _L = 50 Ω, See Figure 1		45	65	ns
t _{PHL} Propagation delay time, high-to-low-level output			30	50	
t _{TLH} Transition time, low-to-high-level output			13	25	
t _{THL} Transition time, high-to-low-level output			10	20	
V _{OH} High-level output voltage after switching	V _S = 55 V, I _O ≈ 300 mA, See Figure 2	V _S -18			mV

logic symbol†

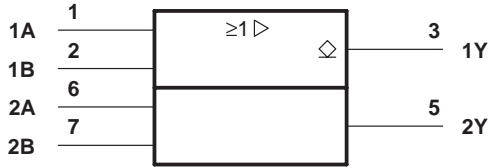

† This symbol is in accordance with ANSI/IEEE Std 91-1984 and IEC Publication 617-12.

logic diagram (positive logic)

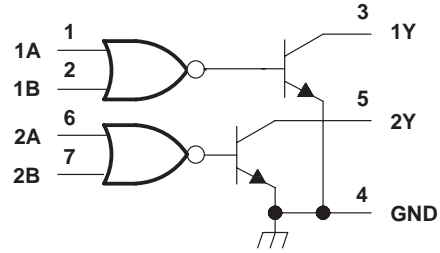

FUNCTION TABLE
(each driver)

A	B	Y
L	L	L (on state)
L	H	H (off state)
H	L	H (off state)
H	H	H (off state)

positive logic:
 $Y = A + B$ or $\overline{A} \overline{B}$

schematic (each driver)

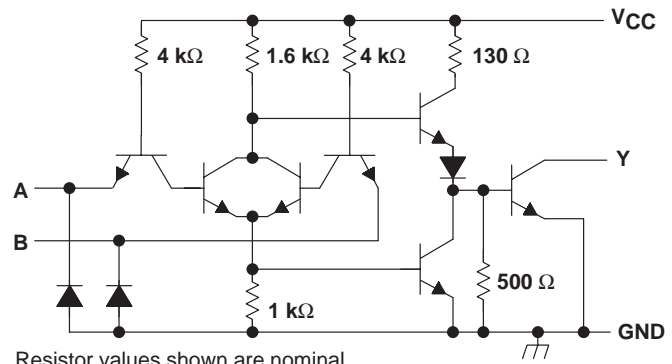

electrical characteristics over recommended operating free-air temperature range

PARAMETER	TEST CONDITIONS	SN75473			UNIT
		MIN	TYP‡	MAX	
V_{IK} Input clamp voltage	$V_{CC} = 4.75 \text{ V}$, $I_I = -12 \text{ mA}$	-1.2	-1.5		V
I_{OH} High-level output current	$V_{CC} = 4.75 \text{ V}$, $V_{IH} = 2 \text{ V}$, $V_{OH} = 70 \text{ V}$			100	μA
V_{OL} Low-level output voltage	$V_{CC} = 4.75 \text{ V}$, $V_{IL} = 0.8 \text{ V}$, $I_{OL} = 100 \text{ mA}$	0.25	0.4		V
	$V_{CC} = 4.75 \text{ V}$, $V_{IL} = 0.8 \text{ V}$, $I_{OL} = 300 \text{ mA}$	0.5	0.7		
I_I Input current at maximum input voltage	$V_{CC} = 5.25 \text{ V}$, $V_I = 5.5 \text{ V}$			1	mA
I_{IH} High-level input current	$V_{CC} = 5.25 \text{ V}$, $V_I = 2.4 \text{ V}$			40	μA
I_{IL} Low-level input current	$V_{CC} = 5.25 \text{ V}$, $V_I = 0.4 \text{ V}$	-1	-1.6		mA
I_{CCH} Supply current, outputs high	$V_{CC} = 5.25 \text{ V}$, $V_I = 5 \text{ V}$	8	11		mA
I_{CCL} Supply current, outputs low	$V_{CC} = 5.25 \text{ V}$, $V_I = 0$	58	76		mA

‡ All typical values are at $V_{CC} = 5 \text{ V}$, $T_A = 25^\circ\text{C}$.

switching characteristics, $V_{CC} = 5 \text{ V}$, $T_A = 25^\circ\text{C}$

PARAMETER	TEST CONDITIONS	SN75473			UNIT
		MIN	TYP	MAX	
t_{PLH} Propagation delay time, low-to-high-level output	$I_O \approx 200 \text{ mA}$, $C_L = 15 \text{ pF}$, $R_L = 50 \Omega$, See Figure 1		30	55	ns
t_{PHL} Propagation delay time, high-to-low-level output			25	40	
t_{TLH} Transition time, low-to-high-level output			8	25	
t_{THL} Transition time, high-to-low-level output			10	25	
V_{OH} High-level output voltage after switching	$V_S = 55 \text{ V}$, See Figure 2	$I_O \approx 300 \text{ mA}$,	$V_S - 18$		mV

SN75471 THRU SN75473 DUAL PERIPHERAL DRIVERS

SLRS024 – DECEMBER 1976 – REVISED MAY 1990

PARAMETER MEASUREMENT INFORMATION

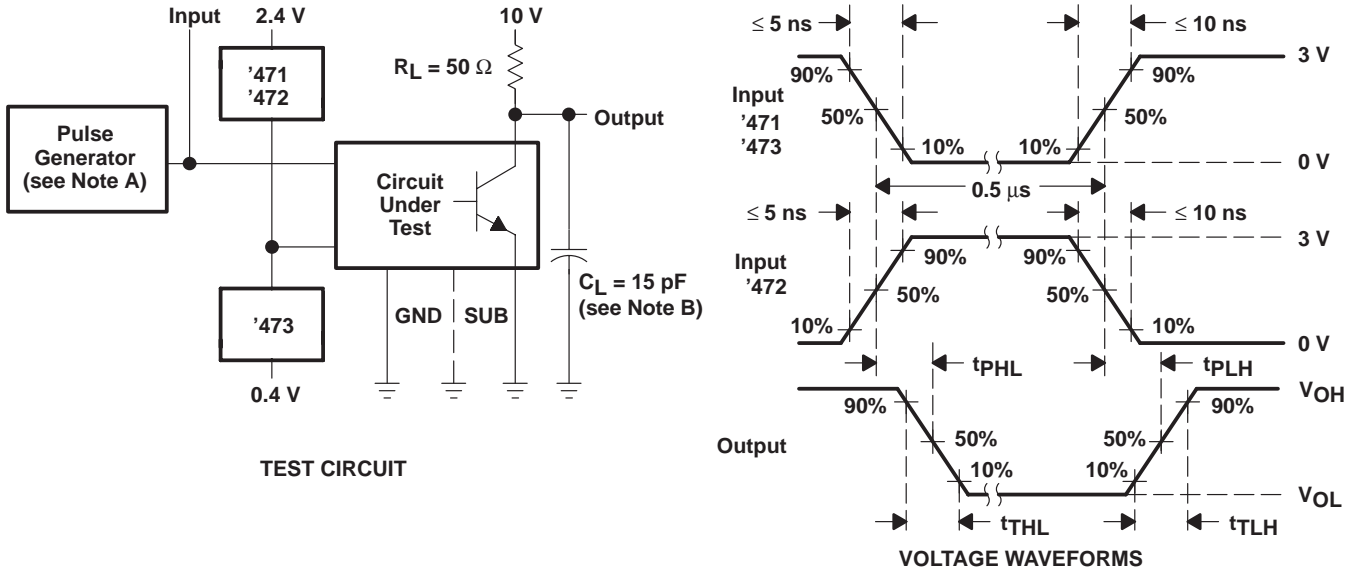

NOTES: A. The pulse generator has the following characteristics: $\text{PRR} \leq 1 \text{ MHz}$, $Z_O \approx 50 \Omega$.
 B. C_L includes probe and jig capacitance.

Figure 1. Switching Times

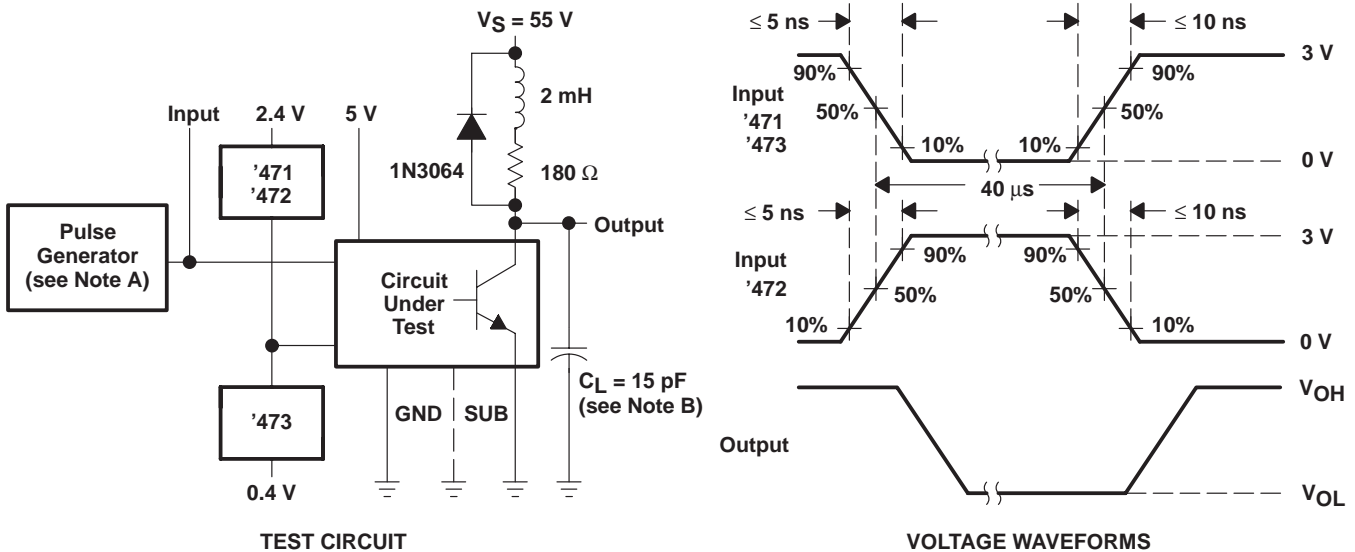

NOTES: A. The pulse generator has the following characteristics: $\text{PRR} \leq 12.5 \text{ kHz}$, $Z_O \approx 50 \Omega$.
 B. C_L includes probe and jig capacitance.

Figure 2. Latch-Up Test

PACKAGING INFORMATION

Orderable Device	Status ⁽¹⁾	Package Type	Package Drawing	Pins	Package Qty	Eco Plan ⁽²⁾	Lead/Ball Finish	MSL Peak Temp ⁽³⁾
SN75471D	ACTIVE	SOIC	D	8	75	Pb-Free (RoHS)	CU NIPDAU	Level-2-260C-1 YEAR/ Level-1-235C-UNLIM
SN75471DR	ACTIVE	SOIC	D	8	2500	Pb-Free (RoHS)	CU NIPDAU	Level-2-260C-1 YEAR/ Level-1-235C-UNLIM
SN75471P	ACTIVE	PDIP	P	8	50	Pb-Free (RoHS)	CU NIPDAU	Level-NC-NC-NC
SN75472D	ACTIVE	SOIC	D	8	75	Pb-Free (RoHS)	CU NIPDAU	Level-2-250C-1 YEAR
SN75472P	ACTIVE	PDIP	P	8	50	Pb-Free (RoHS)	CU NIPDAU	Level-NC-NC-NC
SN75473D	OBSOLETE	SOIC	D	8		TBD	Call TI	Call TI
SN75473P	OBSOLETE	PDIP	P	8		TBD	Call TI	Call TI

⁽¹⁾ The marketing status values are defined as follows:

ACTIVE: Product device recommended for new designs.

LIFEBUY: TI has announced that the device will be discontinued, and a lifetime-buy period is in effect.

NRND: Not recommended for new designs. Device is in production to support existing customers, but TI does not recommend using this part in a new design.

PREVIEW: Device has been announced but is not in production. Samples may or may not be available.

OBSOLETE: TI has discontinued the production of the device.

⁽²⁾ Eco Plan - The planned eco-friendly classification: Pb-Free (RoHS) or Green (RoHS & no Sb/Br) - please check <http://www.ti.com/productcontent> for the latest availability information and additional product content details.

TBD: The Pb-Free/Green conversion plan has not been defined.

Pb-Free (RoHS): TI's terms "Lead-Free" or "Pb-Free" mean semiconductor products that are compatible with the current RoHS requirements for all 6 substances, including the requirement that lead not exceed 0.1% by weight in homogeneous materials. Where designed to be soldered at high temperatures, TI Pb-Free products are suitable for use in specified lead-free processes.

Green (RoHS & no Sb/Br): TI defines "Green" to mean Pb-Free (RoHS compatible), and free of Bromine (Br) and Antimony (Sb) based flame retardants (Br or Sb do not exceed 0.1% by weight in homogeneous material)

⁽³⁾ MSL, Peak Temp. -- The Moisture Sensitivity Level rating according to the JEDEC industry standard classifications, and peak solder temperature.

Important Information and Disclaimer:The information provided on this page represents TI's knowledge and belief as of the date that it is provided. TI bases its knowledge and belief on information provided by third parties, and makes no representation or warranty as to the accuracy of such information. Efforts are underway to better integrate information from third parties. TI has taken and continues to take reasonable steps to provide representative and accurate information but may not have conducted destructive testing or chemical analysis on incoming materials and chemicals. TI and TI suppliers consider certain information to be proprietary, and thus CAS numbers and other limited information may not be available for release.

In no event shall TI's liability arising out of such information exceed the total purchase price of the TI part(s) at issue in this document sold by TI to Customer on an annual basis.