

SN75172 QUADRUPLE DIFFERENTIAL LINE DRIVER

SLLS038B – OCTOBER 1980 – REVISED MAY 1995

- Meets or Exceeds the Requirements of ANSI Standards EIA/TIA-422-B and RS-485 and ITU Recommendation V.11
- Designed for Multipoint Transmission on Long Bus Lines in Noisy Environments
- 3-State Outputs
- Common-Mode Output Voltage Range of -7 V to 12 V
- Active-High and Active-Low Enables
- Thermal Shutdown Protection
- Positive- and Negative-Current Limiting
- Operates From Single 5-V Supply
- Logically Interchangeable With AM26LS31

description

The SN75172 is a monolithic quadruple differential line driver with 3-state outputs. It is designed to meet the requirements of ANSI Standards EIA/TIA-422-B and RS-485 and ITU Recommendation V.11. The device is optimized for balanced multipoint bus transmission at rates of up to 4 megabaud. Each driver features wide positive and negative common-mode output voltage ranges, making it suitable for party-line applications in noisy environments.

The SN75172 provides positive- and negative-current limiting and thermal shutdown for protection from line fault conditions on the transmission bus line. Shutdown occurs at a junction temperature of approximately 150°C . This device offers optimum performance when used with the SN75173 or SN75175 quadruple differential line receivers.

The SN75172 is characterized for operation from 0°C to 70°C .

**N PACKAGE
(TOP VIEW)**

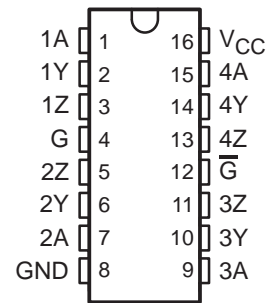

**DW PACKAGE
(TOP VIEW)**

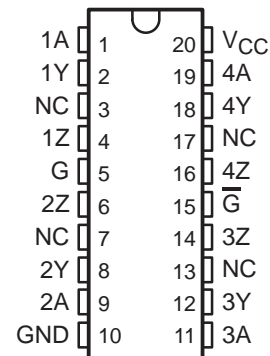

NC – No internal connection

**FUNCTION TABLE
(each driver)**

| INPUT A | ENABLES | | OUTPUTS | |
|------------|---------|-----------|---------|---|
| | G | \bar{G} | Y | Z |
| H | H | X | H | L |
| L | H | X | L | H |
| H | X | L | H | L |
| L | X | L | L | H |
| X | L | H | Z | Z |

H = high level, L = low level, X = irrelevant,
Z = high impedance (off)



Please be aware that an important notice concerning availability, standard warranty, and use in critical applications of Texas Instruments semiconductor products and disclaimers thereto appears at the end of this data sheet.

PRODUCTION DATA information is current as of publication date. Products conform to specifications per the terms of Texas Instruments standard warranty. Production processing does not necessarily include testing of all parameters.

**TEXAS
INSTRUMENTS**

POST OFFICE BOX 655303 • DALLAS, TEXAS 75265

Copyright © 1995, Texas Instruments Incorporated

SN75172 QUADRUPLE DIFFERENTIAL LINE DRIVER

SLLS038B – OCTOBER 1980 – REVISED MAY 1995

logic symbol†

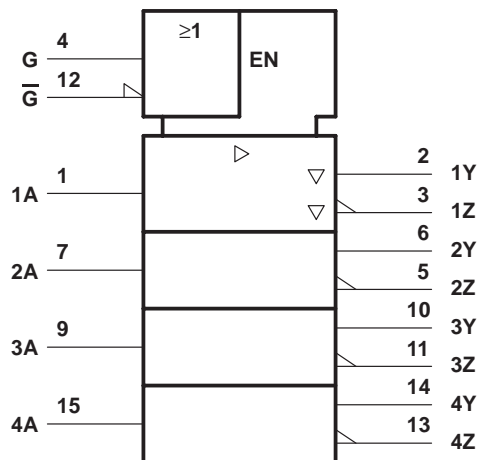

† This symbol is in accordance with ANSI/IEEE Std 91-1984 and IEC Publication 617-12. Terminal numbers shown are for the N package.

logic diagram (positive logic)

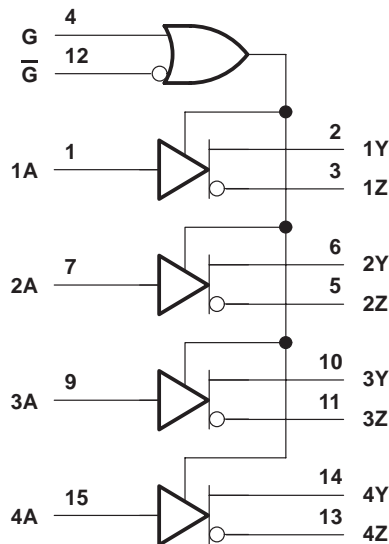

absolute maximum ratings over operating free-air temperature (unless otherwise noted)‡

| | |
|--|------------------------------|
| Supply voltage, V_{CC} (see Note 1) | 7 V |
| Voltage range at any bus terminal | -10 V to 15 V |
| Input voltage, V_I | 5.5 V |
| Continuous total dissipation | See Dissipation Rating Table |
| Operating free-air temperature range, T_A | 0°C to 70°C |
| Storage temperature range, T_{stg} | -65°C to 150°C |
| Lead temperature 1,6 mm (1/16 inch) from case for 10 seconds | 260°C |

‡ Stresses beyond those listed under "absolute maximum ratings" may cause permanent damage to the device. These are stress ratings only, and functional operation of the device at these or any other conditions beyond those indicated under "recommended operating conditions" is not implied. Exposure to absolute-maximum-rated conditions for extended periods may affect device reliability.

NOTE 1: All voltage values are with respect to the network ground terminal.

DISSIPATION RATING TABLE

| PACKAGE | $T_A \leq 25^\circ\text{C}$ POWER RATING | DERATING FACTOR ABOVE $T_A = 25^\circ\text{C}$ | $T_A = 70^\circ\text{C}$ POWER RATING |
|---------|---|---|--|
| DW | 1125 mW | 9.0 mW/°C | 720 mW |
| N | 1150 mW | 9.2 mW/°C | 736 mW |

SN75172 QUADRUPLE DIFFERENTIAL LINE DRIVER

SLLS038B – OCTOBER 1980 – REVISED MAY 1995

recommended operating conditions

| | MIN | NOM | MAX | UNIT |
|---------------------------------------|------|-----|----------|------|
| Supply voltage, V_{CC} | 4.75 | 5 | 5.25 | V |
| High-level input voltage, V_{IH} | 2 | | | V |
| Low-level input voltage, V_{IL} | | | 0.8 | V |
| Common-mode output voltage, V_{OC} | | | -7 to 12 | V |
| High-level output current, I_{OH} | | | -60 | mA |
| Low-level output current, I_{OL} | | | 60 | mA |
| Operating free-air temperature, T_A | 0 | | 70 | °C |

electrical characteristics over recommended ranges of supply voltage and operating free-air temperature (unless otherwise noted)

| PARAMETER | TEST CONDITIONS | MIN | TYP† | MAX | UNIT | |
|--|--|-------------------------------|------|-----------|---------|----|
| V_{IK} Input clamp voltage | $I_I = -18$ mA | | | -1.5 | V | |
| V_O Output voltage | $I_O = 0$ | 0 | | 6 | V | |
| V_{OH} High-level output voltage | $V_{IH} = 2$ V, $V_{IL} = 0.8$ V, $I_{OH} = -33$ mA | | 3.7 | | V | |
| V_{OL} Low-level output voltage | $V_{IH} = 2$ V, $V_{IL} = 0.8$ V, $I_{OH} = 33$ mA | | 1.1 | | V | |
| $ V_{OD1} $ Differential output voltage | $I_O = 0$ | 1.5 | | 6 | V | |
| $ V_{OD2} $ Differential output voltage | $R_L = 100$ Ω , See Figure 1 | $1/2 V_{OD1}$ or 2^\ddagger | | | V | |
| | $R_L = 54$ Ω , See Figure 1 | 1.5 | 2.5 | 5 | V | |
| V_{OD3} Differential output voltage | See Note 2 | 1.5 | | 5 | V | |
| $\Delta V_{OD} $ Change in magnitude of differential output voltage§ | $R_L = 54$ Ω or 100 Ω , See Figure 1 | | | ± 0.2 | V | |
| V_{OC} Common-mode output voltage¶ | | | | +3 -1 | V | |
| $\Delta V_{OC} $ Change in magnitude of common-mode output voltage§ | | | | ± 0.2 | V | |
| I_O Output current with power off | $V_{CC} = 0$, $V_O = -7$ V to 12 V | | | ± 100 | μ A | |
| I_{OZ} High-impedance-state output current | $V_O = -7$ V to 12 V | | | ± 100 | μ A | |
| I_{IH} High-level input current | $V_I = 2.7$ V | | | 20 | μ A | |
| I_{IL} Low-level input current | $V_I = 0.5$ V | | | -360 | μ A | |
| I_{OS} Short-circuit output current | $V_O = -7$ V | | | -180 | mA | |
| | $V_O = V_{CC}$ | | | 180 | | |
| | $V_O = 12$ V | | | 500 | | |
| I_{CC} Supply current (all drivers) | No load | Outputs enabled | | 38 | 60 | mA |
| | | Outputs disabled | | 18 | 40 | |

† All typical values are at $V_{CC} = 5$ V and $T_A = 25^\circ$ C.

‡ The minimum V_{OD2} with a 100- Ω load is either $1/2 V_{OD1}$ or 2 V, whichever is greater.

§ $\Delta|V_{OD}|$ and $\Delta|V_{OC}|$ are the changes in magnitude of V_{OD} and V_{OC} , respectively, that occur when the input is changed from a high level to a low level.

¶ In ANSI Standard EIA/TIA-422-B, V_{OC} , which is the average of the two output voltages with respect to ground, is called output offset voltage, V_{OS} .

NOTE 2: See Figure 3-5 of EIA Standard RS-485.

SN75172 QUADRUPLE DIFFERENTIAL LINE DRIVER

SLLS038B – OCTOBER 1980 – REVISED MAY 1995

SYMBOL EQUIVALENTS

| DATA SHEET PARAMETER | EIA/TIA-422-B | RS-485 |
|----------------------|---------------------------|--|
| V_O | V_{oa}, V_{ob} | V_{oa}, V_{ob} |
| $ V_{OD1} $ | V_o | V_o |
| $ V_{OD2} $ | $V_t (R_L = 100 \Omega)$ | $V_t (R_L = 54 \Omega)$ |
| $ V_{OD2} $ | | V_t (Test Termination Measurement 2) |
| $\Delta V_{OD} $ | $ V_t - \bar{V}_t $ | $ V_t - \bar{V}_t $ |
| V_{OC} | $ V_{os} $ | $ V_{os} $ |
| $\Delta V_{OC} $ | $ V_{os} - \bar{V}_{os} $ | $ V_{os} - \bar{V}_{os} $ |
| I_{OS} | $ I_{sa} , I_{sb} $ | |
| I_O | $ I_{xa} , I_{xb} $ | I_{ia}, I_{ib} |

switching characteristics, $V_{CC} = 5 V$, $T_A = 25^\circ C$

| PARAMETER | TEST CONDITIONS | MIN | TYP | MAX | UNIT |
|---|-----------------------------------|-----|-----|-----|------|
| $t_d(OD)$ Differential-output delay time | $R_L = 54 \Omega$, See Figure 2 | | 45 | 65 | ns |
| $t_t(OD)$ Differential-output transition time | | | 80 | 120 | ns |
| t_{pZH} Output enable time to high level | $R_L = 110 \Omega$, See Figure 3 | | 80 | 120 | ns |
| t_{pZL} Output enable time to low level | $R_L = 110 \Omega$, See Figure 4 | | 45 | 80 | ns |
| t_{PHZ} Output disable time from high level | $R_L = 110 \Omega$, See Figure 3 | | 78 | 115 | ns |
| t_{PLZ} Output disable time from low level | $R_L = 110 \Omega$, See Figure 4 | | 18 | 30 | ns |

PARAMETER MEASUREMENT INFORMATION

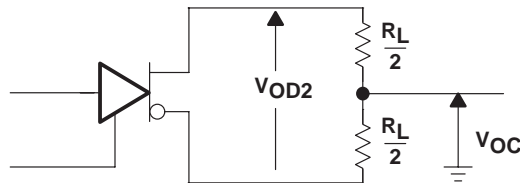
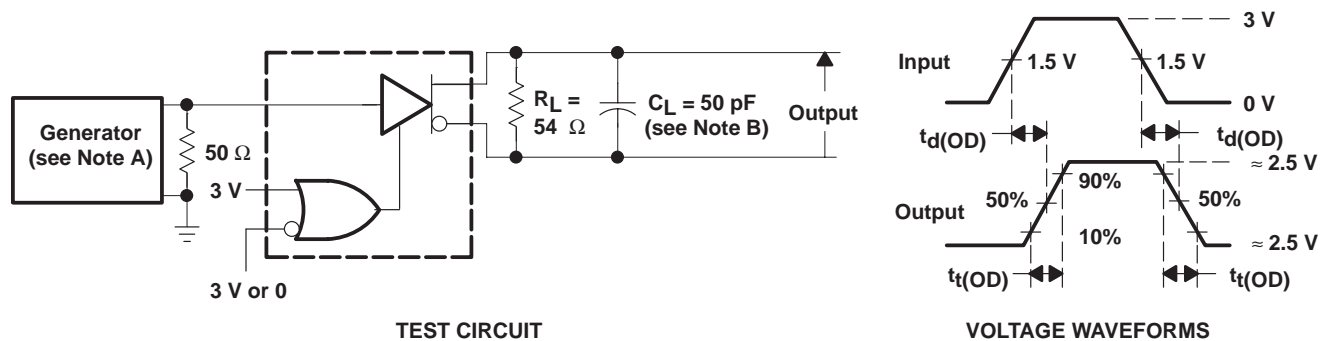

Figure 1. Differential and Common-Mode Output Voltages



- NOTES: A. The input pulse is supplied by a generator having the following characteristics: $t_r \leq 5 \text{ ns}$, $t_f \leq 5 \text{ ns}$, $\text{PRR} \leq 1 \text{ MHz}$, duty cycle = 50%, $Z_O = 50 \Omega$.
B. C_L includes probe and stray capacitance.

Figure 2. Differential-Output Test Circuit and Voltage Waveforms

PARAMETER MEASUREMENT INFORMATION

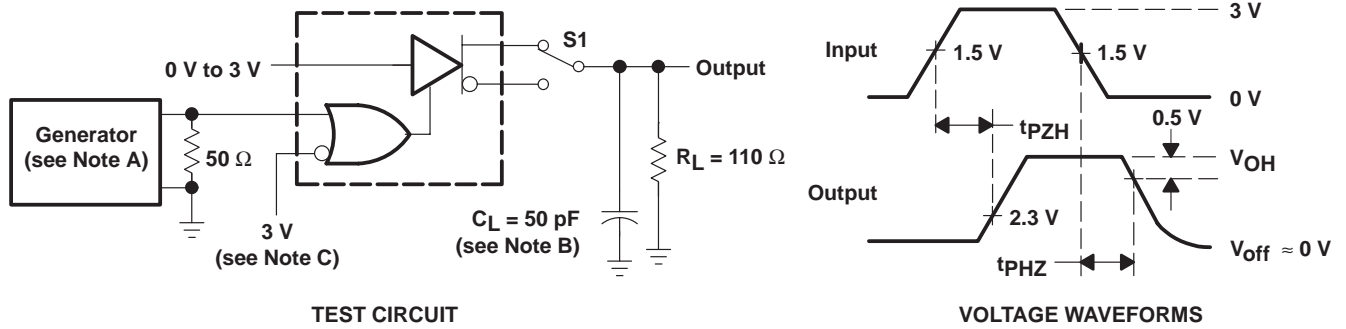

- NOTES. A. The input pulse is supplied by a generator having the following characteristics: PRR \leq 1 MHz, duty cycle = 50%, $t_r \leq$ 5 ns, $t_f \leq$ 5 ns, $Z_O = 50 \Omega$.
 B. C_L includes probe and stray capacitance.
 C. To test the active-low enable \overline{G} , ground G and apply an inverted waveform to \overline{G} .

Figure 3. Test Circuit and Voltage Waveforms

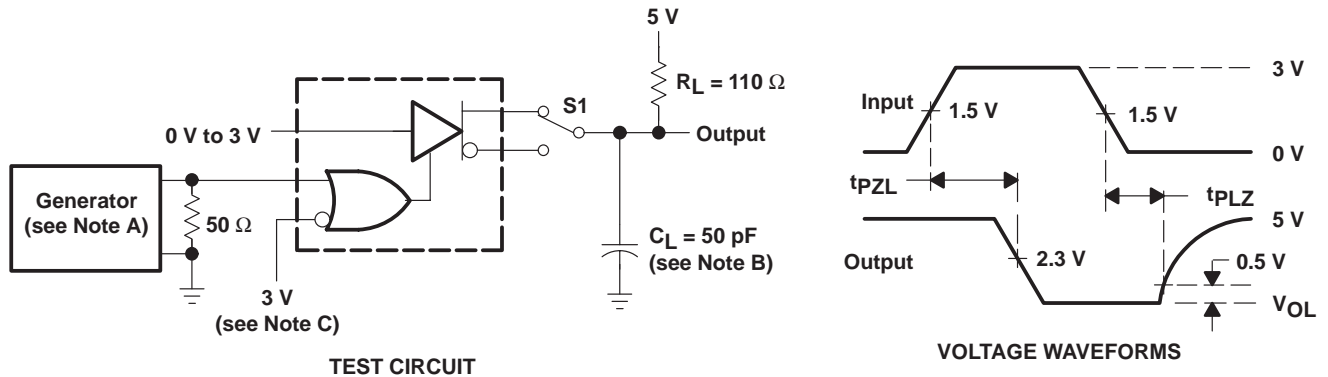

- NOTES. A. The input pulse is supplied by a generator having the following characteristics: PRR \leq 1 MHz, duty cycle = 50%, $t_r \leq$ 5 ns, $t_f \leq$ 5 ns, $Z_O = 50 \Omega$.
 B. C_L includes probe and stray capacitance.
 C. To test the active-low enable \overline{G} , ground G and apply an inverted waveform to \overline{G} .

Figure 4. Test Circuit and Voltage Waveforms

SN75172 QUADRUPLE DIFFERENTIAL LINE DRIVER

SLLS038B – OCTOBER 1980 – REVISED MAY 1995

TYPICAL CHARACTERISTICS

HIGH-LEVEL OUTPUT VOLTAGE
vs
HIGH-LEVEL OUTPUT CURRENT

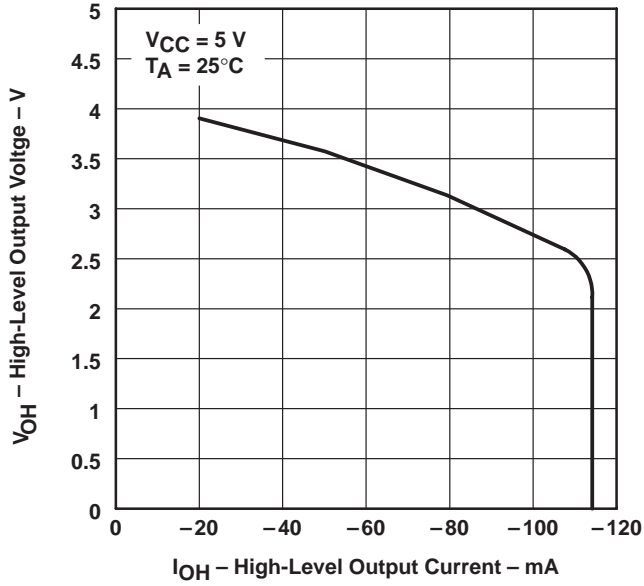

Figure 5

LOW-LEVEL OUTPUT VOLTAGE
vs
LOW-LEVEL OUTPUT CURRENT

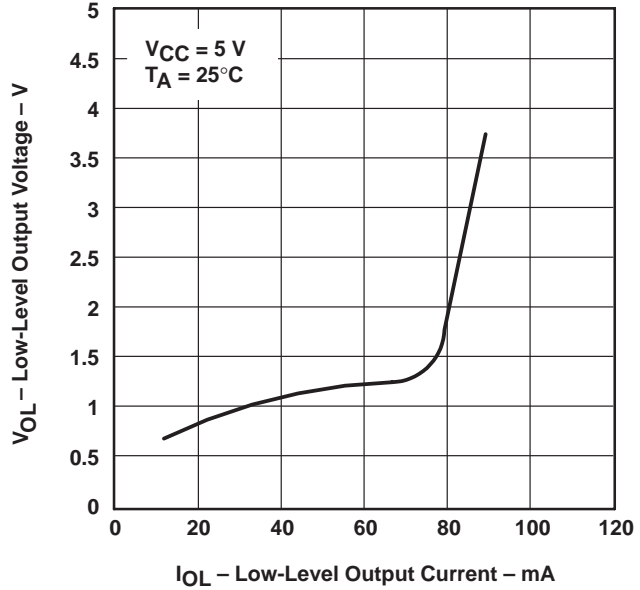

Figure 6

DIFFERENTIAL OUTPUT VOLTAGE
vs
OUTPUT CURRENT

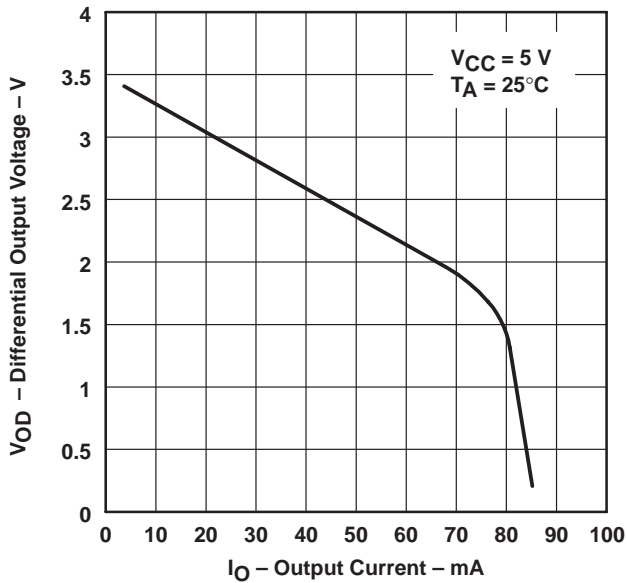

Figure 7

OUTPUT CURRENT
vs
OUTPUT VOLTAGE

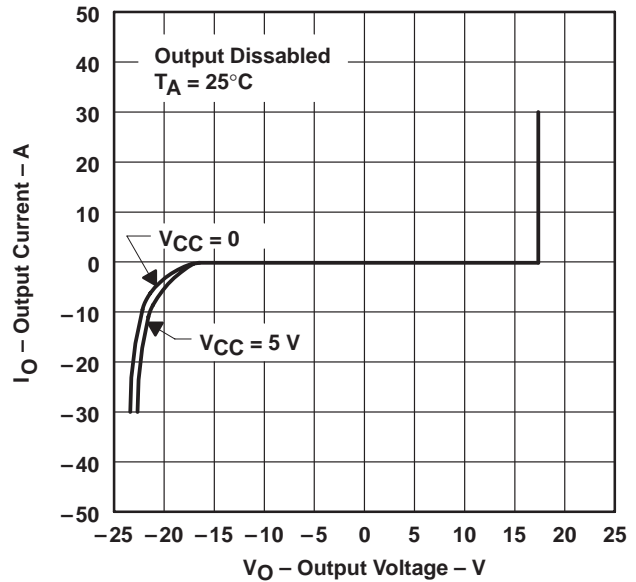

Figure 8

TYPICAL CHARACTERISTICS

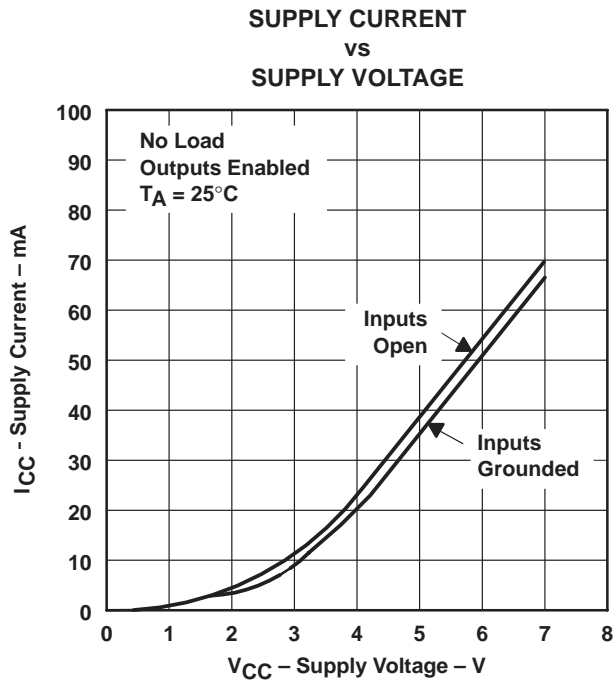

Figure 9

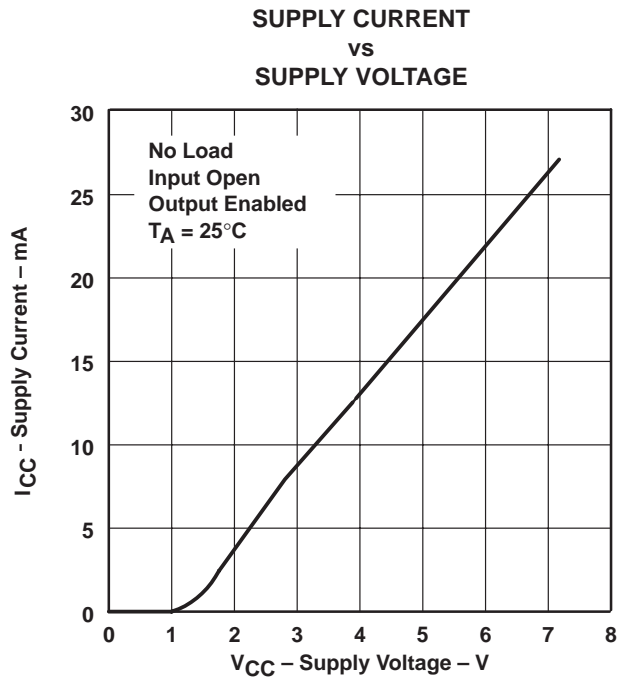
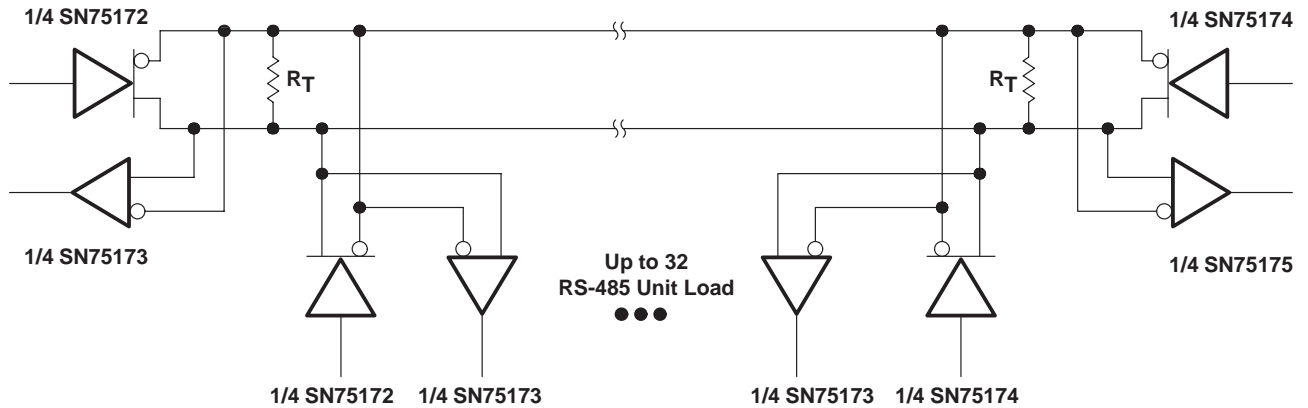

Figure 10

APPLICATION INFORMATION



NOTE A: The line length should be terminated at both ends in its characteristic impedance ($R_T = Z_0$). Stub lengths off the main line should be kept as short as possible.

Figure 11

PACKAGING INFORMATION

| Orderable Device | Status ⁽¹⁾ | Package Type | Package Drawing | Pins | Package Qty | Eco Plan ⁽²⁾ | Lead/Ball Finish | MSL Peak Temp ⁽³⁾ |
|------------------|-----------------------|--------------|-----------------|------|-------------|-------------------------|------------------|------------------------------|
| SN75172DW | ACTIVE | SOIC | DW | 20 | 25 | Green (RoHS & no Sb/Br) | CU NIPDAU | Level-1-260C-UNLIM |
| SN75172DWE4 | ACTIVE | SOIC | DW | 20 | 25 | Green (RoHS & no Sb/Br) | CU NIPDAU | Level-1-260C-UNLIM |
| SN75172DWR | ACTIVE | SOIC | DW | 20 | 2000 | Green (RoHS & no Sb/Br) | CU NIPDAU | Level-1-260C-UNLIM |
| SN75172DWRE4 | ACTIVE | SOIC | DW | 20 | 2000 | Green (RoHS & no Sb/Br) | CU NIPDAU | Level-1-260C-UNLIM |
| SN75172N | ACTIVE | PDIP | N | 16 | 25 | Pb-Free (RoHS) | CU NIPDAU | N / A for Pkg Type |
| SN75172NE4 | ACTIVE | PDIP | N | 16 | 25 | Pb-Free (RoHS) | CU NIPDAU | N / A for Pkg Type |

⁽¹⁾ The marketing status values are defined as follows:

ACTIVE: Product device recommended for new designs.

LIFEBUY: TI has announced that the device will be discontinued, and a lifetime-buy period is in effect.

NRND: Not recommended for new designs. Device is in production to support existing customers, but TI does not recommend using this part in a new design.

PREVIEW: Device has been announced but is not in production. Samples may or may not be available.

OBSOLETE: TI has discontinued the production of the device.

⁽²⁾ Eco Plan - The planned eco-friendly classification: Pb-Free (RoHS), Pb-Free (RoHS Exempt), or Green (RoHS & no Sb/Br) - please check <http://www.ti.com/productcontent> for the latest availability information and additional product content details.

TBD: The Pb-Free/Green conversion plan has not been defined.

Pb-Free (RoHS): TI's terms "Lead-Free" or "Pb-Free" mean semiconductor products that are compatible with the current RoHS requirements for all 6 substances, including the requirement that lead not exceed 0.1% by weight in homogeneous materials. Where designed to be soldered at high temperatures, TI Pb-Free products are suitable for use in specified lead-free processes.

Pb-Free (RoHS Exempt): This component has a RoHS exemption for either 1) lead-based flip-chip solder bumps used between the die and package, or 2) lead-based die adhesive used between the die and leadframe. The component is otherwise considered Pb-Free (RoHS compatible) as defined above.

Green (RoHS & no Sb/Br): TI defines "Green" to mean Pb-Free (RoHS compatible), and free of Bromine (Br) and Antimony (Sb) based flame retardants (Br or Sb do not exceed 0.1% by weight in homogeneous material)

⁽³⁾ MSL, Peak Temp. -- The Moisture Sensitivity Level rating according to the JEDEC industry standard classifications, and peak solder temperature.

Important Information and Disclaimer:The information provided on this page represents TI's knowledge and belief as of the date that it is provided. TI bases its knowledge and belief on information provided by third parties, and makes no representation or warranty as to the accuracy of such information. Efforts are underway to better integrate information from third parties. TI has taken and continues to take reasonable steps to provide representative and accurate information but may not have conducted destructive testing or chemical analysis on incoming materials and chemicals. TI and TI suppliers consider certain information to be proprietary, and thus CAS numbers and other limited information may not be available for release.

In no event shall TI's liability arising out of such information exceed the total purchase price of the TI part(s) at issue in this document sold by TI to Customer on an annual basis.

N (R-PDIP-T**)

PLASTIC DUAL-IN-LINE PACKAGE

16 PINS SHOWN

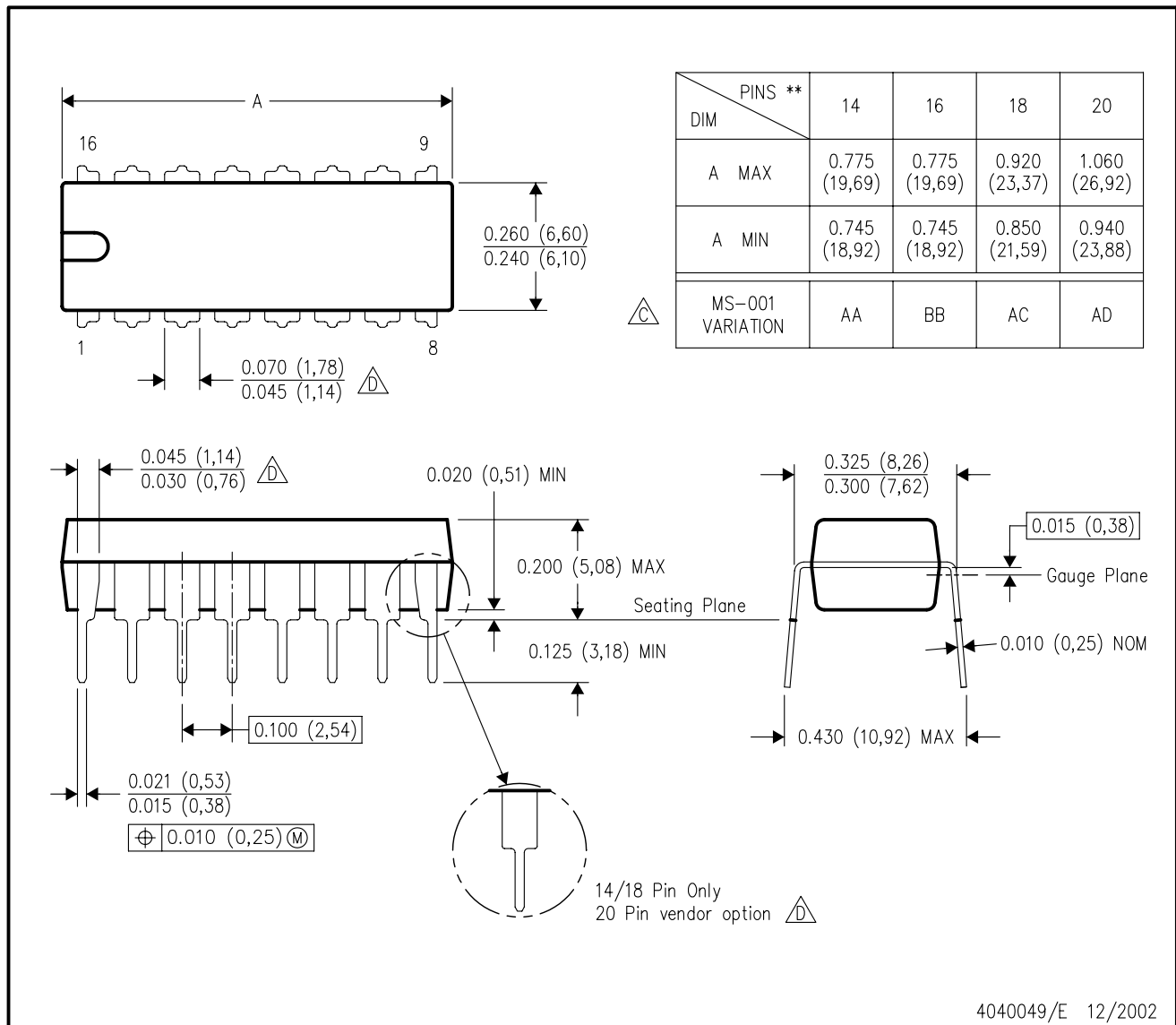

- NOTES:
- A. All linear dimensions are in inches (millimeters).
 - B. This drawing is subject to change without notice.
 - Falls within JEDEC MS-001, except 18 and 20 pin minimum body length (Dim A).
 - The 20 pin end lead shoulder width is a vendor option, either half or full width.

DW (R-PDSO-G20)

PLASTIC SMALL-OUTLINE PACKAGE

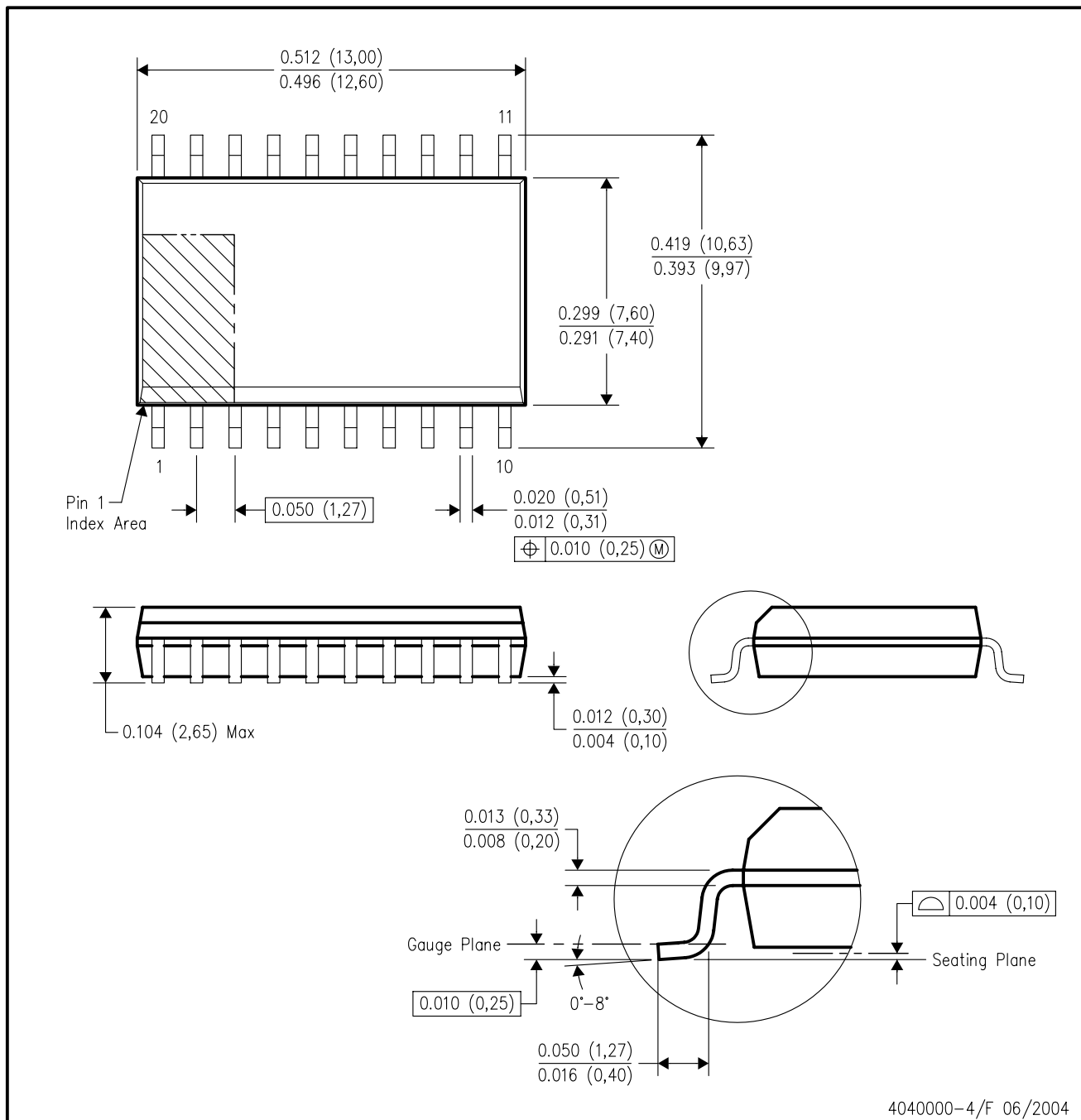

- NOTES:
- A. All linear dimensions are in inches (millimeters).
 - B. This drawing is subject to change without notice.
 - C. Body dimensions do not include mold flash or protrusion not to exceed 0.006 (0,15).
 - D. Falls within JEDEC MS-013 variation AC.

IMPORTANT NOTICE

Texas Instruments Incorporated and its subsidiaries (TI) reserve the right to make corrections, modifications, enhancements, improvements, and other changes to its products and services at any time and to discontinue any product or service without notice. Customers should obtain the latest relevant information before placing orders and should verify that such information is current and complete. All products are sold subject to TI's terms and conditions of sale supplied at the time of order acknowledgment.

TI warrants performance of its hardware products to the specifications applicable at the time of sale in accordance with TI's standard warranty. Testing and other quality control techniques are used to the extent TI deems necessary to support this warranty. Except where mandated by government requirements, testing of all parameters of each product is not necessarily performed.

TI assumes no liability for applications assistance or customer product design. Customers are responsible for their products and applications using TI components. To minimize the risks associated with customer products and applications, customers should provide adequate design and operating safeguards.

TI does not warrant or represent that any license, either express or implied, is granted under any TI patent right, copyright, mask work right, or other TI intellectual property right relating to any combination, machine, or process in which TI products or services are used. Information published by TI regarding third-party products or services does not constitute a license from TI to use such products or services or a warranty or endorsement thereof. Use of such information may require a license from a third party under the patents or other intellectual property of the third party, or a license from TI under the patents or other intellectual property of TI.

Reproduction of information in TI data books or data sheets is permissible only if reproduction is without alteration and is accompanied by all associated warranties, conditions, limitations, and notices. Reproduction of this information with alteration is an unfair and deceptive business practice. TI is not responsible or liable for such altered documentation.

Resale of TI products or services with statements different from or beyond the parameters stated by TI for that product or service voids all express and any implied warranties for the associated TI product or service and is an unfair and deceptive business practice. TI is not responsible or liable for any such statements.

Following are URLs where you can obtain information on other Texas Instruments products and application solutions:

| Products | | Applications | |
|--------------------|--|---------------------|--|
| Amplifiers | amplifier.ti.com | Audio | www.ti.com/audio |
| Data Converters | dataconverter.ti.com | Automotive | www.ti.com/automotive |
| DSP | dsp.ti.com | Broadband | www.ti.com/broadband |
| Interface | interface.ti.com | Digital Control | www.ti.com/digitalcontrol |
| Logic | logic.ti.com | Military | www.ti.com/military |
| Power Mgmt | power.ti.com | Optical Networking | www.ti.com/opticalnetwork |
| Microcontrollers | microcontroller.ti.com | Security | www.ti.com/security |
| Low Power Wireless | www.ti.com/lpw | Telephony | www.ti.com/telephony |
| | | Video & Imaging | www.ti.com/video |
| | | Wireless | www.ti.com/wireless |

Mailing Address: Texas Instruments
Post Office Box 655303 Dallas, Texas 75265