

SN75161B, SN75162B OCTAL GENERAL-PURPOSE INTERFACE BUS TRANSCEIVERS

SLLS005B – OCTOBER 1980 – REVISED MAY 1995

- Meets IEEE Standard 488-1978 (GPIB)
- 8-Channel Bidirectional Transceivers
- Power-Up/Power-Down Protection (Glitch Free)
- Designed to Implement Control Bus Interface
- SN75161B Designed for Single Controller
- SN75162B Designed for Multiple Controllers
- High-Speed, Low-Power Schottky Circuitry
- Low Power Dissipation . . . 72 mW Max Per Channel
- Fast Propagation Times . . . 22 ns Max
- High-Impedance pnp Inputs
- Receiver Hysteresis . . . 650 mV Typ
- Bus-Terminating Resistors Provided on Driver Outputs
- No Loading of Bus When Device Is Powered Down ($V_{CC} = 0$)

description

The SN75161B and SN75162B eight-channel, general-purpose interface bus transceivers are monolithic, high-speed, low-power Schottky devices designed to meet the requirements of IEEE Standard 488-1978. Each transceiver is designed to provide the bus-management and data-transfer signals between operating units of a single- or multiple-controller instrumentation system. When combined with the SN75160B octal bus transceiver, the SN75161B or SN75162B provides the complete 16-wire interface for the IEEE-488 bus.

The SN75161B and SN75162B feature eight driver-receiver pairs connected in a front-to-back configuration to form input/output (I/O) ports at both the bus and terminal sides. A power-up/-down disable circuit is included on all bus and receiver outputs. This provides glitch-free operation during V_{CC} power up and power down.

SN75161B . . . DW OR N PACKAGE

(TOP VIEW)

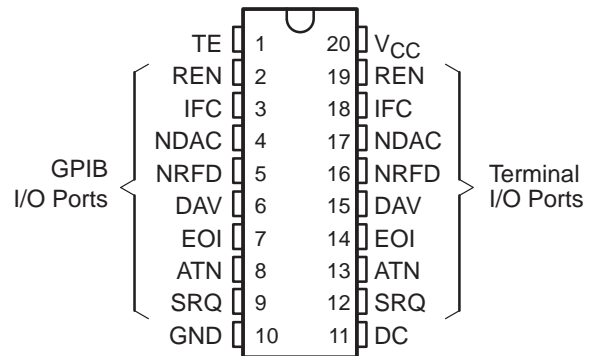

SN75162B . . . DW PACKAGE

(TOP VIEW)

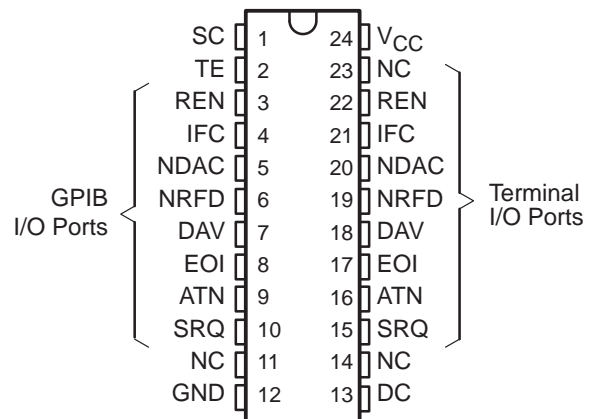

SN75162B . . . N PACKAGE

(TOP VIEW)

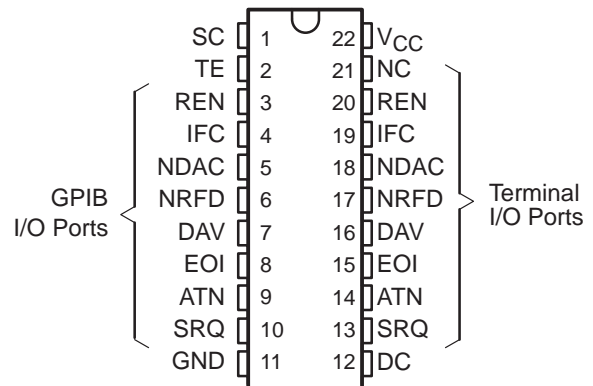

NC – No internal connection



Please be aware that an important notice concerning availability, standard warranty, and use in critical applications of Texas Instruments semiconductor products and disclaimers thereto appears at the end of this data sheet.

PRODUCTION DATA information is current as of publication date. Products conform to specifications per the terms of Texas Instruments standard warranty. Production processing does not necessarily include testing of all parameters.

**TEXAS
INSTRUMENTS**

POST OFFICE BOX 655303 • DALLAS, TEXAS 75265

Copyright © 1995, Texas Instruments Incorporated

SN75161B, SN75162B OCTAL GENERAL-PURPOSE INTERFACE BUS TRANSCEIVERS

SLLS005B – OCTOBER 1980 – REVISED MAY 1995

DISSIPATION RATING TABLE

PACKAGE	$T_A \leq 25^\circ\text{C}$ POWER RATING	DERATING FACTOR ABOVE $T_A = 25^\circ\text{C}$	$T_A = 70^\circ\text{C}$ POWER RATING
DW (20 pin)	1125 mW	9.0 mW/°C	720 mW
DW (24 pin)	1350 mW	10.8 mW/°C	864 mW
N (20 pin)	1150 mW	9.2 mW/°C	736 mW
N (22 pin)	1700 mW	13.6 mW/°C	1088 mW

recommended operating conditions

		MIN	NOM	MAX	UNIT
Supply voltage, V_{CC}		4.75	5	5.25	V
High-level input voltage, V_{IH}		2			V
Low-level input voltage, V_{IL}		0.8			V
High-level output current, I_{OH}	Bus ports with 3-state outputs	-5.2			mA
	Terminal ports	-800			μA
Low-level output current, I_{OL}	Bus ports	48			mA
	Terminal ports	16			
Operating free-air temperature, T_A		0	70		°C



SN75161B, SN75162B

OCTAL GENERAL-PURPOSE INTERFACE BUS TRANSCEIVERS

SLLS005B – OCTOBER 1980 – REVISED MAY 1995

electrical characteristics over recommended ranges of supply voltage and operating free-air temperature (unless otherwise noted)

PARAMETER		TEST CONDITIONS		MIN	TYP†	MAX	UNIT
V_{IK}	Input clamp voltage		$I_I = -18 \text{ mA}$	-0.8	-1.5		V
V_{hys}	Hysteresis voltage ($V_{IT+} - V_{IT-}$)	Bus	See Figure 7	0.4	0.65		V
$V_{OH}‡$	High-level output voltage	Terminal	$I_{OH} = -800 \mu\text{A}$	2.7	3.5		V
		Bus	$I_{OH} = -5.2 \text{ mA}$	2.5	3.3		
V_{OL}	Low-level output voltage	Terminal	$I_{OL} = 16 \text{ mA}$		0.3	0.5	V
		Bus	$I_{OL} = 48 \text{ mA}$		0.35	0.5	
I_I	Input current at maximum input voltage	Terminal	$V_I = 5.5 \text{ V}$		0.2	100	μA
I_{IH}	High-level input current	Terminal and control inputs	$V_I = 2.7 \text{ V}$		0.1	20	μA
I_{IL}	Low-level input current		$V_I = 0.5 \text{ V}$		-10	-100	μA
$V_{I/O(\text{bus})}$	Voltage at bus port	Driver disabled	$I_{I(\text{bus})} = 0$	2.5	3.0	3.7	V
			$I_{I(\text{bus})} = -12 \text{ mA}$			-1.5	
$I_{I/O(\text{bus})}$	Current into bus port	Power on	Driver disabled	$V_{I(\text{bus})} = -1.5 \text{ V to } 0.4 \text{ V}$	-1.3		mA
				$V_{I(\text{bus})} = 0.4 \text{ V to } 2.5 \text{ V}$	0	-3.2	
				$V_{I(\text{bus})} = 2.5 \text{ V to } 3.7 \text{ V}$		2.5	
				$V_{I(\text{bus})} = 3.7 \text{ V to } 5 \text{ V}$	0	-3.2	
				$V_{I(\text{bus})} = 5 \text{ V to } 5.5 \text{ V}$	0.7	2.5	
		Power off	$V_{CC} = 0, V_{I(\text{bus})} = 0 \text{ V to } 2.5 \text{ V}$		-40	μA	
I_{OS}	Short-circuit output current	Terminal		-15	-35	-75	mA
		Bus		-25	-50	-125	
I_{CC}	Supply current		No load, TE, DE, and SC low			110	mA
$C_{I/O(\text{bus})}$	Bus-port capacitance		$V_{CC} = 5 \text{ V to } 0, V_{I/O} = 0 \text{ to } 2 \text{ V}, f = 1 \text{ MHz}$		16		pF

† All typical values are at $V_{CC} = 5 \text{ V}, T_A = 25^\circ\text{C}$.

‡ V_{OH} applies for 3-state outputs only.



SN75161B, SN75162B OCTAL GENERAL-PURPOSE INTERFACE BUS TRANSCEIVERS

SLLS005B – OCTOBER 1980 – REVISED MAY 1995

switching characteristics, $V_{CC} = 5\text{ V}$, $C_L = 15\text{ pF}$, $T_A = 25^\circ\text{C}$ (unless otherwise noted)

PARAMETER		FROM (INPUT)	TO (OUTPUT)	TEST CONDITIONS	MIN	TYP	MAX	UNIT
t _{PLH}	Propagation delay time, low- to high-level output	Terminal	Bus	C _L = 30 pF, See Figure 1		14	20	ns
t _{PHL}	Propagation delay time, high- to low-level output					14	20	
t _{PLH}	Propagation delay time, low- to high-level output	Terminal	Bus (SRQ, NDAC, NRFD)	C _L = 30 pF, See Figure 1		29	35	ns
t _{PLH}	Propagation delay time, low- to high-level output	Bus	Terminal	C _L = 30 pF, See Figure 2		10	20	ns
t _{PHL}	Propagation delay time, high- to low-level output					15	22	
t _{PZH}	Output enable time to high level	TE,DC, or SC	Bus (ATN, EOI, REN, IFC, and DAV)	See Figure 3			60	ns
t _{PHZ}	Output disable time from high level						45	
t _{PZL}	Output enable time to low level						60	
t _{PLZ}	Output disable time from low level						55	
t _{PZH}	Output enable time to high level	TE,DC, or SC	Terminal	See Figure 4			55	ns
t _{PHZ}	Output disable time from high level						50	
t _{PZL}	Output enable time to low level						45	
t _{PLZ}	Output disable time from low level						55	



PACKAGING INFORMATION

Orderable Device	Status ⁽¹⁾	Package Type	Package Drawing	Pins	Package Qty	Eco Plan ⁽²⁾	Lead/Ball Finish	MSL Peak Temp ⁽³⁾
SN75161BDW	ACTIVE	SOIC	DW	20	25	Green (RoHS & no Sb/Br)	CU NIPDAU	Level-1-260C-UNLIM
SN75161BDWR	ACTIVE	SOIC	DW	20	2000	Green (RoHS & no Sb/Br)	CU NIPDAU	Level-1-260C-UNLIM
SN75161BDWRE4	ACTIVE	SOIC	DW	20	2000	Green (RoHS & no Sb/Br)	CU NIPDAU	Level-1-260C-UNLIM
SN75161BN	ACTIVE	PDIP	N	20	20	Pb-Free (RoHS)	CU NIPDAU	Level-NC-NC-NC
SN75161BNE4	ACTIVE	PDIP	N	20	20	Pb-Free (RoHS)	CU NIPDAU	Level-NC-NC-NC
SN75162BDW	ACTIVE	SOIC	DW	24	25	Green (RoHS & no Sb/Br)	CU NIPDAU	Level-1-260C-UNLIM
SN75162BDWE4	ACTIVE	SOIC	DW	24	25	Green (RoHS & no Sb/Br)	CU NIPDAU	Level-1-260C-UNLIM
SN75162BDWR	ACTIVE	SOIC	DW	24	2000	Green (RoHS & no Sb/Br)	CU NIPDAU	Level-1-260C-UNLIM
SN75162BDWRE4	ACTIVE	SOIC	DW	24	2000	Green (RoHS & no Sb/Br)	CU NIPDAU	Level-1-260C-UNLIM
SN75162BN	OBSOLETE	PDIP	N	22		TBD	Call TI	Call TI

⁽¹⁾ The marketing status values are defined as follows:

ACTIVE: Product device recommended for new designs.

LIFEBUY: TI has announced that the device will be discontinued, and a lifetime-buy period is in effect.

NRND: Not recommended for new designs. Device is in production to support existing customers, but TI does not recommend using this part in a new design.

PREVIEW: Device has been announced but is not in production. Samples may or may not be available.

OBSOLETE: TI has discontinued the production of the device.

⁽²⁾ Eco Plan - The planned eco-friendly classification: Pb-Free (RoHS) or Green (RoHS & no Sb/Br) - please check <http://www.ti.com/productcontent> for the latest availability information and additional product content details.

TBD: The Pb-Free/Green conversion plan has not been defined.

Pb-Free (RoHS): TI's terms "Lead-Free" or "Pb-Free" mean semiconductor products that are compatible with the current RoHS requirements for all 6 substances, including the requirement that lead not exceed 0.1% by weight in homogeneous materials. Where designed to be soldered at high temperatures, TI Pb-Free products are suitable for use in specified lead-free processes.

Green (RoHS & no Sb/Br): TI defines "Green" to mean Pb-Free (RoHS compatible), and free of Bromine (Br) and Antimony (Sb) based flame retardants (Br or Sb do not exceed 0.1% by weight in homogeneous material)

⁽³⁾ MSL, Peak Temp. -- The Moisture Sensitivity Level rating according to the JEDEC industry standard classifications, and peak solder temperature.

Important Information and Disclaimer: The information provided on this page represents TI's knowledge and belief as of the date that it is provided. TI bases its knowledge and belief on information provided by third parties, and makes no representation or warranty as to the accuracy of such information. Efforts are underway to better integrate information from third parties. TI has taken and continues to take reasonable steps to provide representative and accurate information but may not have conducted destructive testing or chemical analysis on incoming materials and chemicals. TI and TI suppliers consider certain information to be proprietary, and thus CAS numbers and other limited information may not be available for release.

In no event shall TI's liability arising out of such information exceed the total purchase price of the TI part(s) at issue in this document sold by TI to Customer on an annual basis.