

SN74SSTL16857 14-BIT SSTL_2 REGISTERED BUFFER

SCAS625C – FEBRUARY 1999 – REVISED OCTOBER 1999

- Member of the Texas Instruments *Widebus™* Family
- Supports SSTL_2 Signal Data Inputs and Outputs
- Supports LVTTTL Switching Levels on the RESET Pin
- Differential CLK Signal
- Flow-Through Architecture Optimizes PCB Layout
- Meets SSTL_2 Class II Specifications
- Latch-Up Performance Exceeds 100 mA Per JESD 78, Class II
- ESD Protection Exceeds JESD 22
 - 2000-V Human-Body Model (A114-A)
 - 200-V Machine Model (A115-A)
 - 1000-V Charged-Device Model (C101)
- Packaged in Plastic Thin Shrink Small-Outline Package

**DGG PACKAGE
(TOP VIEW)**

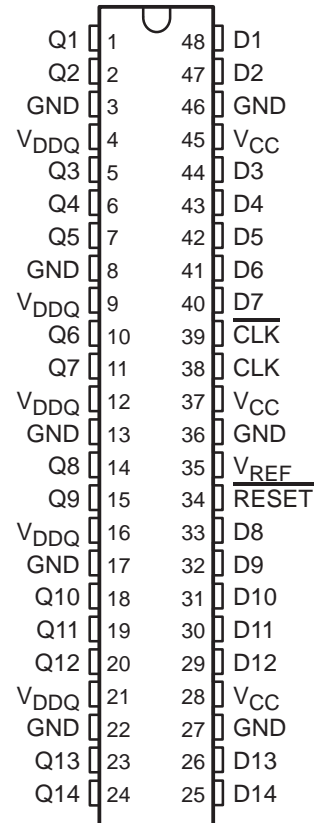

description

This 14-bit registered buffer is designed for 2.3-V to 3.6-V V_{CC} operation and SSTL_2 data input and output levels.

All inputs are compatible with the JEDEC Standard for SSTL_2, except the LVCMOS reset (RESET) input. All outputs are SSTL_2, Class II compatible.

When RESET is low, the differential input receivers are disabled, and undriven (floating) data and clock inputs are allowed. In addition, when RESET is low, all registers are reset, and all outputs are forced low. The LVCMOS RESET input must always be held at a valid logic high or low level.

To ensure defined outputs from the register before a stable clock has been supplied, RESET must be held in the low state during power up.

The SN74SSTL16857 is characterized for operation from 0°C to 70°C.

**FUNCTION TABLE
(each flip-flop)**

INPUTS				OUTPUT Q
<u>RESET</u>	<u>CLK</u>	CLK	D	
L	X	X	X	L
H	↓	↑	H	H
H	↓	↑	L	L
H	L or H	L or H	X	Q_0



Please be aware that an important notice concerning availability, standard warranty, and use in critical applications of Texas Instruments semiconductor products and disclaimers thereto appears at the end of this data sheet.

Widebus is a trademark of Texas Instruments Incorporated.

PRODUCTION DATA information is current as of publication date. Products conform to specifications per the terms of Texas Instruments standard warranty. Production processing does not necessarily include testing of all parameters.



POST OFFICE BOX 655303 • DALLAS, TEXAS 75265

Copyright © 1999, Texas Instruments Incorporated

SN74SSTL16857

14-BIT SSTL_2 REGISTERED BUFFER

SCAS625C – FEBRUARY 1999 – REVISED OCTOBER 1999

logic diagram (positive logic)

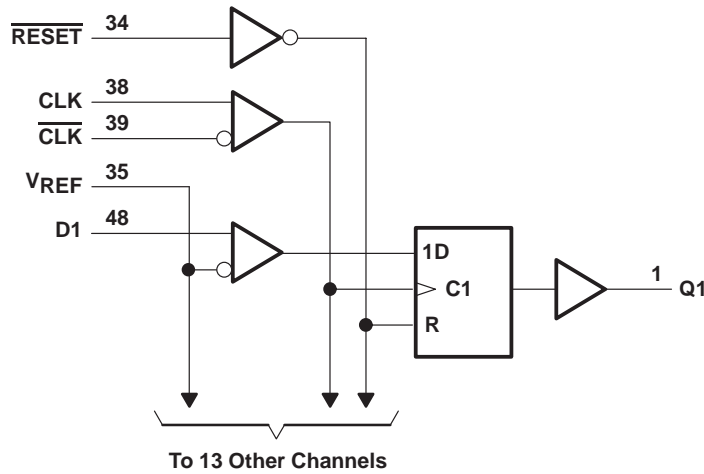

absolute maximum ratings over operating free-air temperature range (unless otherwise noted)[†]

Supply voltage range, V_{CC} or V_{DDQ}	-0.5 V to 4.6 V
Input voltage range, V_I (see Note 1)	-0.5 V to $V_{DDQ} + 0.5$ V
Output voltage range, V_O (see Notes 1 and 2)	-0.5 V to $V_{DDQ} + 0.5$ V
Input clamp current, I_{IK} ($V_I < 0$)	-50 mA
Output clamp current, I_{OK} ($V_O < 0$)	-50 mA
Continuous output current, I_O ($V_O = 0$ to V_{DDQ})	± 50 mA
Continuous current through each V_{CC} , V_{DDQ} , or GND	± 100 mA
Package thermal impedance, θ_{JA} (see Note 3)	70°C/W
Storage temperature range, T_{stg}	-65°C to 150°C

[†] Stresses beyond those listed under “absolute maximum ratings” may cause permanent damage to the device. These are stress ratings only, and functional operation of the device at these or any other conditions beyond those indicated under “recommended operating conditions” is not implied. Exposure to absolute-maximum-rated conditions for extended periods may affect device reliability.

- NOTES:
1. The input and output negative-voltage ratings may be exceeded if the input and output clamp-current ratings are observed.
 2. Current flows only when the output is in the high state and $V_O > V_{DDQ}$.
 3. The package thermal impedance is calculated in accordance with JESD 51.

recommended operating conditions (see Note 4)

		MIN	NOM	MAX	UNIT	
V _{CC}	Supply voltage	V _{DDQ}		3.6	V	
V _{DDQ}	Output supply voltage	2.3		2.7	V	
V _{REF}	Reference voltage (V _{REF} = V _{DDQ} /2)	1.15	1.25	1.35	V	
V _{TT}	Termination voltage	V _{REF} -40 mV	V _{REF}	V _{REF} +40 mV	V	
V _I	Input voltage	0		V _{CC}	V	
V _{IH}	AC high-level input voltage	Data inputs	V _{REF} +350 mV		V	
V _{IL}	AC low-level input voltage	Data inputs	V _{REF} -350 mV		V	
V _{IH}	DC high-level input voltage	Data inputs	V _{REF} +180 mV		V	
V _{IL}	DC low-level input voltage	Data inputs	V _{REF} -180 mV		V	
V _{IH}	High-level input voltage	$\overline{\text{RESET}}$	2		V	
V _{IL}	Low-level input voltage	$\overline{\text{RESET}}$	0.8		V	
V _{ICR}	Common-mode input voltage range	CLK, $\overline{\text{CLK}}$	0.97		1.53	V
V _{I(PP)}	Peak-to-peak input voltage	CLK, $\overline{\text{CLK}}$	360		mV	
I _{OH}	High-level output current				-20	mA
I _{OL}	Low-level output current				20	mA
T _A	Operating free-air temperature	0		70	°C	

NOTE 4: All unused inputs of the device must be held at V_{CC} or GND to ensure proper device operation. Refer to the TI application report, *Implications of Slow or Floating CMOS Inputs*, literature number SCBA004.

SN74SSTL16857

14-BIT SSTL_2 REGISTERED BUFFER

SCAS625C – FEBRUARY 1999 – REVISED OCTOBER 1999

electrical characteristics over recommended operating free-air temperature range (unless otherwise noted)

PARAMETER		TEST CONDITIONS		V _{CC}	MIN	TYP	MAX	UNIT
V _{IK}		I _I = -18 mA		2.3 V			-1.2	V
V _{OH}		I _{OH} = -100 μA		2.3 V to 2.7 V	V _{CC} -0.2			V
		I _{OH} = -8 mA		2.3 V	1.95			
		I _{OH} = -16 mA			1.95			
V _{OL}		I _{OL} = 100 μA		2.3 V to 2.7 V			0.2	V
		I _{OL} = 8 mA		2.3 V			0.35	
		I _{OL} = 16 mA					0.35	
I _I	Data inputs	V _I = 1.7 V or 0.8V		V _{REF} = 1.15 V or 1.35 V	2.7 V	±5		μA
		V _I = 2.7 V or 0				±5		
		V _I = 1.7 V or 0.8V		V _{REF} = 1.15 V or 1.35 V	3.6 V	±5		
		V _I = 2.7 V or 0				±5		
	CLK, $\overline{\text{CLK}}$	V _I = 1.7 V or 0.8V		V _{REF} = 1.15 V or 1.35 V	2.7 V	±1		mA
		V _I = 2.7 V or 0				±1		
		V _I = 1.7 V or 0.8V		V _{REF} = 1.15 V or 1.35 V	3.6 V	±1		
		V _I = 2.7 V or 0				±1		
	$\overline{\text{RESET}}$	V _I = V _{CC} or GND			2.7 V	±5		μA
					3.6 V	±5		
	V _{REF}	V _{REF} = 1.15 V or 1.35 V			2.7 V	±5		
					3.6 V	±5		
I _{CC}	V _I = 1.7 V or 0.8 V		I _O = 0	2.7 V	90		mA	
	V _I = 2.7 V or 0				90			
	V _I = 1.7 V or 0.8 V		I _O = 0	3.6 V	90			
	V _I = 2.7 V or 0				90			
C _i	$\overline{\text{RESET}}$	V _I = 1.7 V or 0.8 V			2.5 V†	3		pF
	Data inputs					2.5		
	$\overline{\text{RESET}}$	V _I = 1.7 V or 0.8 V			3.3 V‡	3		
	Data inputs					2.5		

† All typical values are at V_{CC} = 2.5 V, T_A = 25°C.

‡ All typical values are at V_{CC} = 3.3 V, T_A = 25°C.

timing requirements over recommended operating free-air temperature range (unless otherwise noted) (see Figure 1)

		V _{CC} = 2.5 V ± 0.2 V		V _{CC} = 3.3 V ± 0.3 V		UNIT
		MIN	MAX	MIN	MAX	
f _{clock}	Clock frequency	150		150		MHz
t _w	Pulse duration, CLK, $\overline{\text{CLK}}$ high or low	3.3		3.3		ns
t _{su}	Setup time	Data before CLK↑, $\overline{\text{CLK}}$ ↓		1.1	1.75	ns
		$\overline{\text{RESET}}$ high before CLK↑, $\overline{\text{CLK}}$ ↓		0.6	1.1	
t _h	Hold time, data after CLK↑, $\overline{\text{CLK}}$ ↓	0.7		0.7		ns



SN74SSTL16857

14-BIT SSTL_2 REGISTERED BUFFER

SCAS625C – FEBRUARY 1999 – REVISED OCTOBER 1999

switching characteristics over recommended operating free-air temperature range (unless otherwise noted) (see Figure 1)

PARAMETER	FROM (INPUT)	TO (OUTPUT)	V _{CC} = 2.5 V ± 0.2 V		V _{CC} = 3.3 V ± 0.3 V		UNIT
			MIN	MAX	MIN	MAX	
f _{max}			150		150		MHz
t _{pd}	CLK and $\overline{\text{CLK}}$	Q	1.5	3.8	1.4	3.7	ns
t _{PHL}	$\overline{\text{RESET}}$	Q	1.5	4.3	1.4	3.5	ns

SN74SSTL16857 14-BIT SSTL_2 REGISTERED BUFFER

SCAS625C – FEBRUARY 1999 – REVISED OCTOBER 1999

PARAMETER MEASUREMENT INFORMATION $V_{CC} = 2.5\text{ V} \pm 0.2\text{ V}$ AND $V_{CC} = 3.3\text{ V} \pm 0.3\text{ V}$

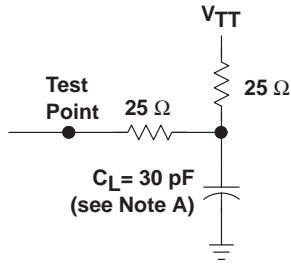

LOAD CIRCUIT

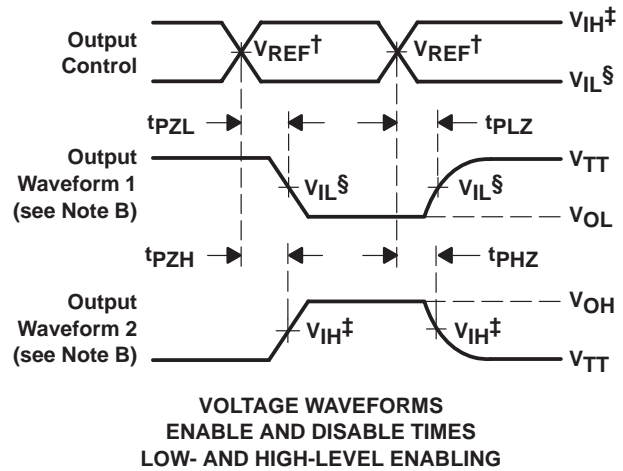
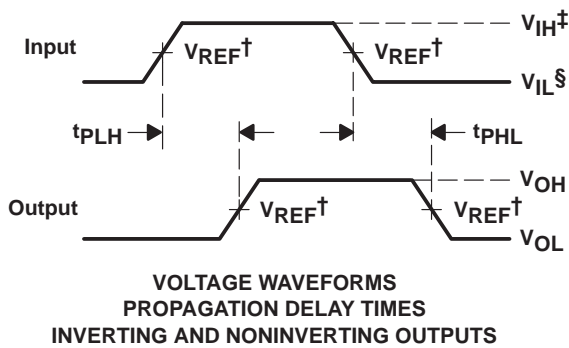
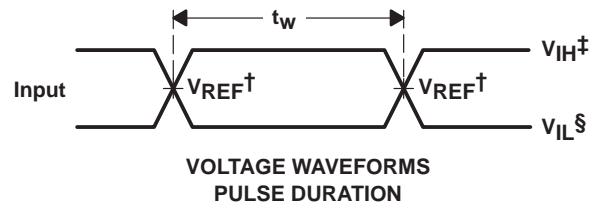
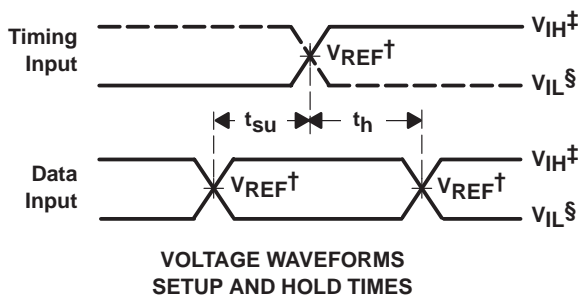

† $V_{REF} = V_{DDQ}/2$

‡ $V_{IH} = V_{REF} + 350\text{ mV}$ (AC voltage levels)

§ $V_{IL} = V_{REF} - 350\text{ mV}$ (AC voltage levels)

NOTES: A. C_L includes probe and jig capacitance.

B. Waveform 1 is for an output with internal conditions such that the output is low except when disabled by the output control. Waveform 2 is for an output with internal conditions such that the output is high except when disabled by the output control.

C. All input pulses are supplied by generators having the following characteristics: $PRR \leq 10\text{ MHz}$, $Z_O = 50\ \Omega$, $t_r \leq 1.25\text{ ns/V}$, $t_f \leq 1.25\text{ ns/V}$.

D. The outputs are measured one at a time with one transition per measurement.

E. $V_{TT} = V_{REF} = V_{DDQ}/2$

F. t_{PZL} and t_{PHZ} are the same as t_{dis} .

G. t_{PZL} and t_{PZH} are the same as t_{en} .

H. t_{PLH} and t_{PHL} are the same as t_{pd} .

Figure 1. Load Circuit and Voltage Waveforms

PACKAGING INFORMATION

Orderable Device	Status ⁽¹⁾	Package Type	Package Drawing	Pins	Package Qty	Eco Plan ⁽²⁾	Lead/Ball Finish	MSL Peak Temp ⁽³⁾
74SSTL16857DGGRE4	ACTIVE	TSSOP	DGG	48	2000	Green (RoHS & no Sb/Br)	CU NIPDAU	Level-1-260C-UNLIM
SN74SSTL16857DGGR	ACTIVE	TSSOP	DGG	48	2000	Green (RoHS & no Sb/Br)	CU NIPDAU	Level-1-260C-UNLIM

⁽¹⁾ The marketing status values are defined as follows:

ACTIVE: Product device recommended for new designs.

LIFEBUY: TI has announced that the device will be discontinued, and a lifetime-buy period is in effect.

NRND: Not recommended for new designs. Device is in production to support existing customers, but TI does not recommend using this part in a new design.

PREVIEW: Device has been announced but is not in production. Samples may or may not be available.

OBsolete: TI has discontinued the production of the device.

⁽²⁾ Eco Plan - The planned eco-friendly classification: Pb-Free (RoHS) or Green (RoHS & no Sb/Br) - please check <http://www.ti.com/productcontent> for the latest availability information and additional product content details.

TBD: The Pb-Free/Green conversion plan has not been defined.

Pb-Free (RoHS): TI's terms "Lead-Free" or "Pb-Free" mean semiconductor products that are compatible with the current RoHS requirements for all 6 substances, including the requirement that lead not exceed 0.1% by weight in homogeneous materials. Where designed to be soldered at high temperatures, TI Pb-Free products are suitable for use in specified lead-free processes.

Green (RoHS & no Sb/Br): TI defines "Green" to mean Pb-Free (RoHS compatible), and free of Bromine (Br) and Antimony (Sb) based flame retardants (Br or Sb do not exceed 0.1% by weight in homogeneous material)

⁽³⁾ MSL, Peak Temp. -- The Moisture Sensitivity Level rating according to the JEDEC industry standard classifications, and peak solder temperature.

Important Information and Disclaimer:The information provided on this page represents TI's knowledge and belief as of the date that it is provided. TI bases its knowledge and belief on information provided by third parties, and makes no representation or warranty as to the accuracy of such information. Efforts are underway to better integrate information from third parties. TI has taken and continues to take reasonable steps to provide representative and accurate information but may not have conducted destructive testing or chemical analysis on incoming materials and chemicals. TI and TI suppliers consider certain information to be proprietary, and thus CAS numbers and other limited information may not be available for release.

In no event shall TI's liability arising out of such information exceed the total purchase price of the TI part(s) at issue in this document sold by TI to Customer on an annual basis.

DGG (R-PDSO-G**)

PLASTIC SMALL-OUTLINE PACKAGE

48 PINS SHOWN

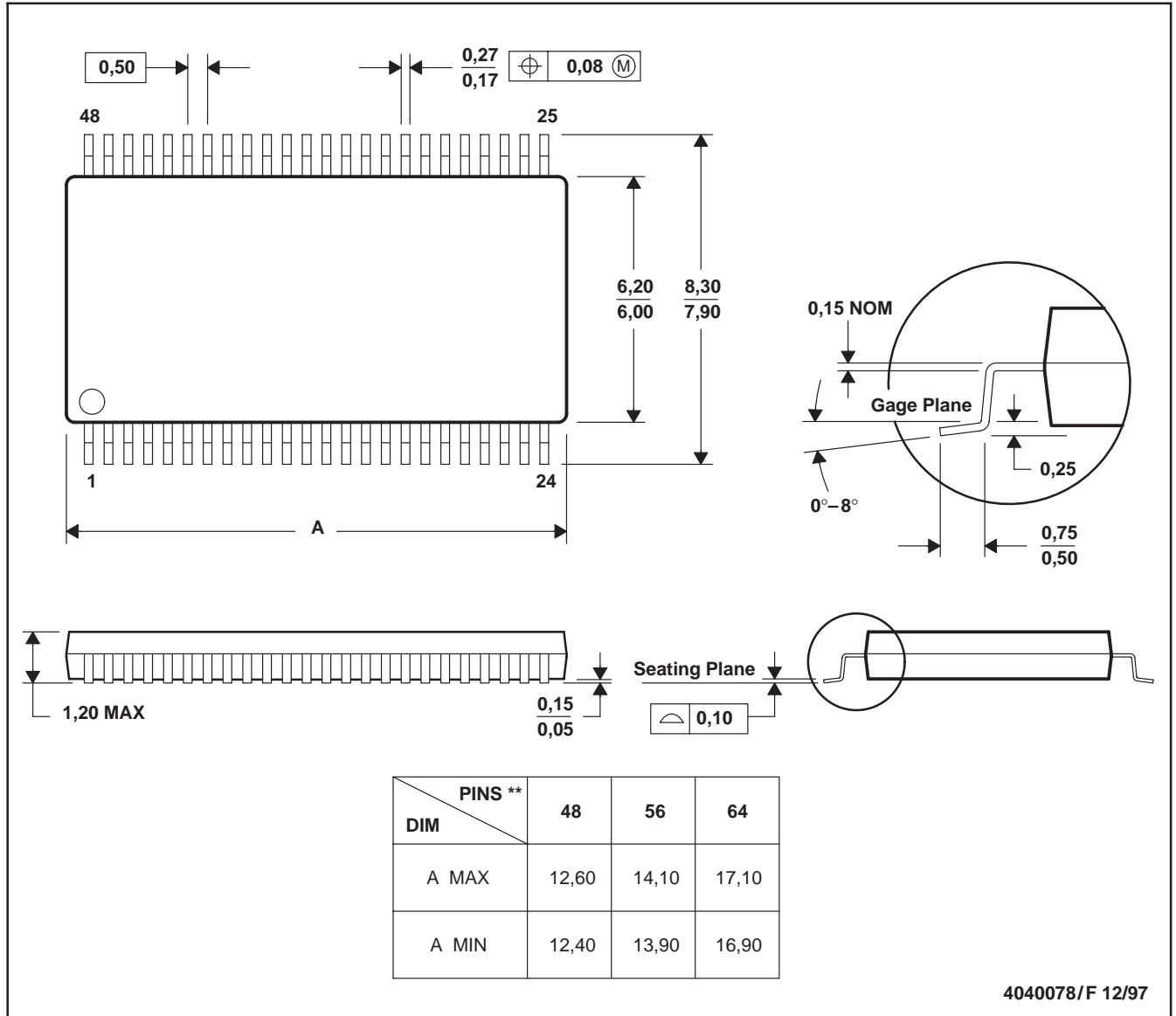

- NOTES: A. All linear dimensions are in millimeters.
 B. This drawing is subject to change without notice.
 C. Body dimensions do not include mold protrusion not to exceed 0,15.
 D. Falls within JEDEC MO-153

IMPORTANT NOTICE

Texas Instruments Incorporated and its subsidiaries (TI) reserve the right to make corrections, modifications, enhancements, improvements, and other changes to its products and services at any time and to discontinue any product or service without notice. Customers should obtain the latest relevant information before placing orders and should verify that such information is current and complete. All products are sold subject to TI's terms and conditions of sale supplied at the time of order acknowledgment.

TI warrants performance of its hardware products to the specifications applicable at the time of sale in accordance with TI's standard warranty. Testing and other quality control techniques are used to the extent TI deems necessary to support this warranty. Except where mandated by government requirements, testing of all parameters of each product is not necessarily performed.

TI assumes no liability for applications assistance or customer product design. Customers are responsible for their products and applications using TI components. To minimize the risks associated with customer products and applications, customers should provide adequate design and operating safeguards.

TI does not warrant or represent that any license, either express or implied, is granted under any TI patent right, copyright, mask work right, or other TI intellectual property right relating to any combination, machine, or process in which TI products or services are used. Information published by TI regarding third-party products or services does not constitute a license from TI to use such products or services or a warranty or endorsement thereof. Use of such information may require a license from a third party under the patents or other intellectual property of the third party, or a license from TI under the patents or other intellectual property of TI.

Reproduction of information in TI data books or data sheets is permissible only if reproduction is without alteration and is accompanied by all associated warranties, conditions, limitations, and notices. Reproduction of this information with alteration is an unfair and deceptive business practice. TI is not responsible or liable for such altered documentation.

Resale of TI products or services with statements different from or beyond the parameters stated by TI for that product or service voids all express and any implied warranties for the associated TI product or service and is an unfair and deceptive business practice. TI is not responsible or liable for any such statements.

Following are URLs where you can obtain information on other Texas Instruments products and application solutions:

Products		Applications	
Amplifiers	amplifier.ti.com	Audio	www.ti.com/audio
Data Converters	dataconverter.ti.com	Automotive	www.ti.com/automotive
DSP	dsp.ti.com	Broadband	www.ti.com/broadband
Interface	interface.ti.com	Digital Control	www.ti.com/digitalcontrol
Logic	logic.ti.com	Military	www.ti.com/military
Power Mgmt	power.ti.com	Optical Networking	www.ti.com/opticalnetwork
Microcontrollers	microcontroller.ti.com	Security	www.ti.com/security
		Telephony	www.ti.com/telephony
		Video & Imaging	www.ti.com/video
		Wireless	www.ti.com/wireless

Mailing Address: Texas Instruments
Post Office Box 655303 Dallas, Texas 75265