

# SN74S225

## 16 × 5 ASYNCHRONOUS FIRST-IN, FIRST-OUT MEMORY WITH 3-STATE OUTPUTS

SDLS207B – SEPTEMBER 1976 – REVISED APRIL 1998

- Independent Asynchronous Inputs and Outputs
- 16 Words by 5 Bits
- DC to 10-MHz Data Rate
- 3-State Outputs
- Packaged in Standard Plastic 300-mil DIPs

### description

This 80-bit active-element memory is a monolithic Schottky-clamped transistor-transistor logic (STTL) array organized as 16 words by 5 bits. A memory system using the SN74S225 easily can be expanded in multiples of 48 words or of 10 bits as shown in Figure 3. The 3-state outputs controlled by a single output-enable ( $\overline{OE}$ ) input make bus connection and multiplexing easy.

A first-in, first-out (FIFO) memory is a storage device that allows data to be written into and read from its array at independent data rates. This FIFO is designed to process data at rates from dc to 10 MHz in a bit-parallel format, word by word.

Reading or writing is done independently, utilizing separate asynchronous data clocks. Data can be written into the array on the low-to-high transition of either load-clock (CLKA, CLKB) input. Data can be read out of the array on the low-to-high transition of the unload-clock (UNCK IN) input (normally high). Writing data into the FIFO can be accomplished in one of two ways:

- In applications not requiring a gated clock control, best results are achieved by applying the clock input to one of the clocks while tying the other clock input high.
- In applications needing a gated clock, the load clock (gate control) must be high for the FIFO to load on the next clock pulse.

CLKA and CLKB can be used interchangeably for either clock gate control or clock input.

Status of the SN74S225 is provided by three outputs. The input-ready (IR) output monitors the status of the last word location and signifies when the memory is full. This output is high whenever the memory is available to accept any data. The unload-clock (UNCK OUT) output also monitors the last word location. This output generates a low-logic-level pulse (synchronized to the internal clock pulse) when the location is vacant. The third status output, output ready (OR), is high when the first word location contains valid data and UNCK IN is high. When UNCK IN goes low, OR will go low and stay low until new valid data is in the first word position. The first word location is defined as the location from which data is provided to the outputs.

The data outputs are noninverted with respect to the data inputs and are 3-state, with a common control input ( $\overline{OE}$ ). When  $\overline{OE}$  is low, the data outputs are enabled to function as totem-pole outputs. A high logic level forces each data output to a high-impedance state while all other inputs and outputs remain active. The clear ( $\overline{CLR}$ ) input invalidates all data stored in the memory array by clearing the control logic and setting OR to a low logic level on the high-to-low transition of a low-active pulse.

The SN74S225 is characterized for operation from 0°C to 70°C.

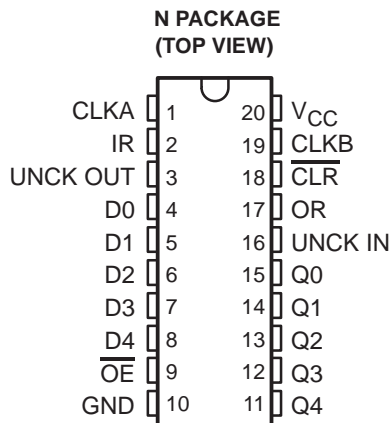

Please be aware that an important notice concerning availability, standard warranty, and use in critical applications of Texas Instruments semiconductor products and disclaimers thereto appears at the end of this data sheet.

PRODUCTION DATA information is current as of publication date. Products conform to specifications per the terms of Texas Instruments standard warranty. Production processing does not necessarily include testing of all parameters.

**TEXAS  
INSTRUMENTS**

POST OFFICE BOX 655303 • DALLAS, TEXAS 75265

Copyright © 1998, Texas Instruments Incorporated

# SN74S225

## 16 × 5 ASYNCHRONOUS FIRST-IN, FIRST-OUT MEMORY WITH 3-STATE OUTPUTS

SDLS207B – SEPTEMBER 1976 – REVISED APRIL 1998

### logic symbol†

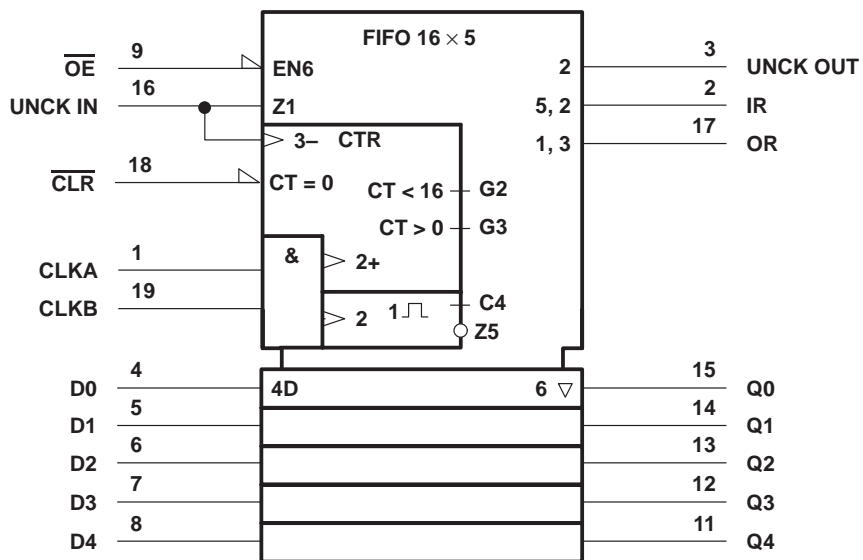

† This symbol is in accordance with ANSI/IEEE Standard 91-1984 and IEC Publication 617-12.



**SN74S225**  
**16 × 5 ASYNCHRONOUS FIRST-IN, FIRST-OUT MEMORY**  
**WITH 3-STATE OUTPUTS**

SDLS207B – SEPTEMBER 1976 – REVISED APRIL 1998

**schematics of inputs and outputs**

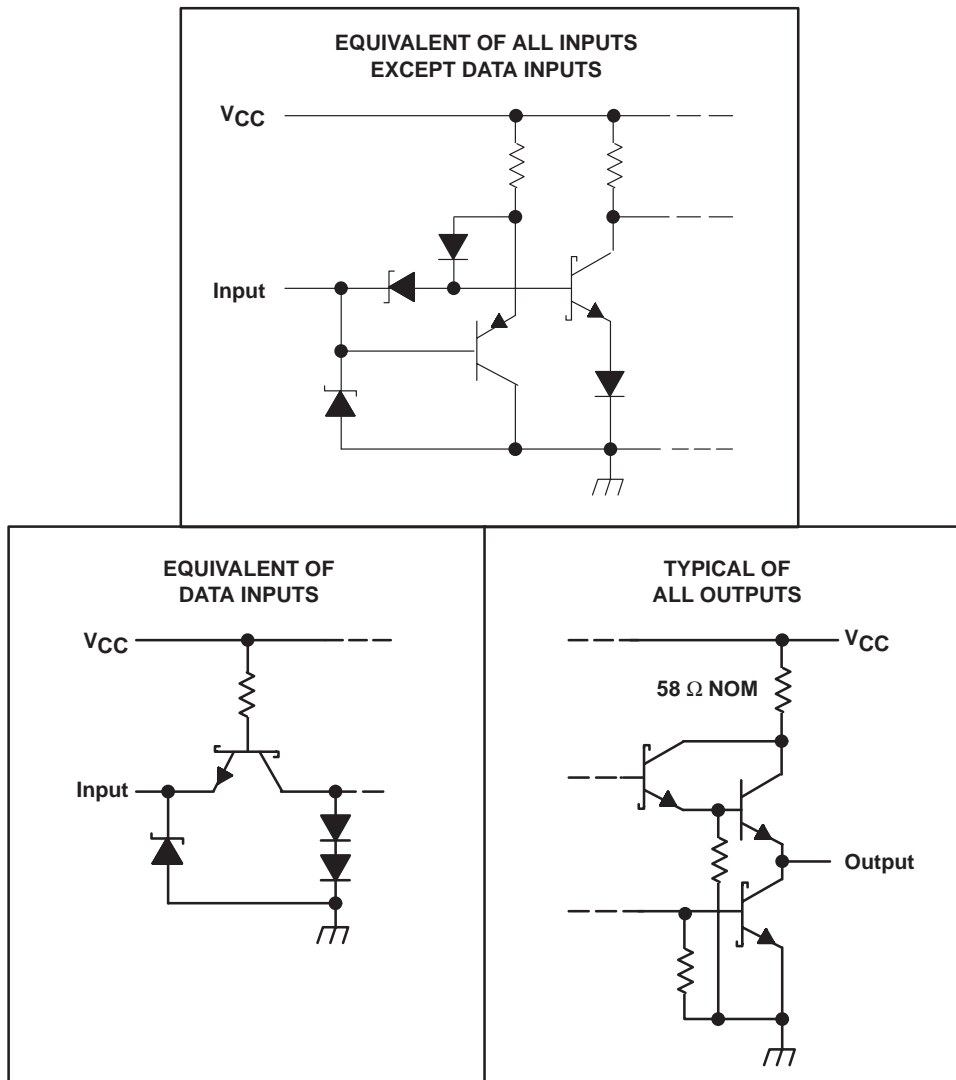

**absolute maximum ratings over operating free-air temperature range (unless otherwise noted)†**

Supply voltage range, $V_{CC}$ (see Note 1)	.....	-0.5 V to 7 V
Input voltage range, $V_I$	.....	-0.5 V to 5.5 V
Off-state output voltage range	.....	-0.5 V to 5.5 V
Package thermal impedance, $\theta_{JA}$ (see Note 2)	.....	67°C/W
Storage temperature range, $T_{stg}$	.....	-65°C to 150°C

† Stresses beyond those listed under “absolute maximum ratings” may cause permanent damage to the device. These are stress ratings only, and functional operation of the device at these or any other conditions beyond those indicated under “recommended operating conditions” is not implied. Exposure to absolute-maximum-rated conditions for extended periods may affect device reliability.

- NOTES: 1. All voltage values are with respect to GND.  
 2. The package thermal impedance is calculated in accordance with JESD 51, except for through-hole packages, which use a trace length of zero.



# SN74S225

## 16 × 5 ASYNCHRONOUS FIRST-IN, FIRST-OUT MEMORY WITH 3-STATE OUTPUTS

SDLS207B – SEPTEMBER 1976 – REVISED APRIL 1998

### recommended operating conditions

		MIN	NOM	MAX	UNIT
V <sub>CC</sub>	Supply voltage	4.75	5	5.25	V
V <sub>IH</sub>	High-level input voltage	2			V
V <sub>IL</sub>	Low-level input voltage			0.8	V
I <sub>OH</sub>	High-level output current	Q outputs		-6.5	mA
		All other outputs		-3.2	
I <sub>OL</sub>	Low-level output current	Q outputs		16	mA
		All other outputs		8	
T <sub>A</sub>	Operating free-air temperature	0		70	°C

### electrical characteristics over recommended operating free-air temperature range (unless otherwise noted)

PARAMETER		TEST CONDITIONS		MIN	TYP†	MAX	UNIT
V <sub>IK</sub>		V <sub>CC</sub> = 4.75 V,	I <sub>I</sub> = -18 mA			-1.2	V
V <sub>OH</sub>	Q outputs	V <sub>CC</sub> = 4.75 V,	I <sub>OL</sub> = -6.5 mA	2.4	2.9		V
	All others	V <sub>CC</sub> = 4.75 V,	I <sub>OL</sub> = -3.2 mA	2.4	2.9		
V <sub>OL</sub>	Q outputs	V <sub>CC</sub> = 4.75 V,	I <sub>OL</sub> = 16 mA	0.35	0.5		V
	All others	V <sub>CC</sub> = 4.75 V,	I <sub>OL</sub> = 8 mA	0.35	0.5		
I <sub>OZH</sub>		V <sub>CC</sub> = 5.25 V,	V <sub>O</sub> = 2.4 V			50	μA
I <sub>OZL</sub>		V <sub>CC</sub> = 5.25 V,	V <sub>O</sub> = 0.5 V			-50	μA
I <sub>I</sub>		V <sub>CC</sub> = 5.25 V,	V <sub>I</sub> = 5.5 V			1	mA
I <sub>IH</sub>	Data	V <sub>CC</sub> = 5.25 V,	V <sub>I</sub> = 2.7 V			40	μA
	All others					25	
I <sub>IL</sub>	Data	V <sub>CC</sub> = 5.25 V,	V <sub>I</sub> = 0.5 V			-1	mA
	All others					-0.25	
I <sub>OS</sub> ‡		V <sub>CC</sub> = 5.25 V,	V <sub>O</sub> = 0	-30		-100	mA
I <sub>CC</sub> §		V <sub>CC</sub> = 5.25 V			80	120	mA

† All typical values are at V<sub>CC</sub> = 5 V, T<sub>A</sub> = 25°C.

‡ Duration of the short circuit should not exceed one second.

§ I<sub>CC</sub> is measured with all inputs grounded and the outputs open.

### timing requirements over recommended operating conditions (unless otherwise noted) (see Figure 1)

		MIN	NOM	MAX	UNIT
f <sub>clock</sub>	Clock frequency			10	MHz
t <sub>w</sub>	Pulse duration	CLKA or CLKB high	25		ns
		UNCK IN low	7		
		CLR low	40		
t <sub>su</sub>	Setup time before CLKA↑ or CLKB↑	Data (see Note 3)	-20		ns
		CLR inactive	25		
t <sub>h</sub>	Hold time after CLKA↑ or CLKB↑	70			ns

NOTE 3: Data must be set up within 20 ns after the load-clock positive transition.

# SN74S225

## 16 × 5 ASYNCHRONOUS FIRST-IN, FIRST-OUT MEMORY WITH 3-STATE OUTPUTS

SDLS207B – SEPTEMBER 1976 – REVISED APRIL 1998

switching characteristics over recommended ranges of supply voltage and operating free-air temperature (unless otherwise noted) (see Figure 1)

PARAMETER	FROM (INPUT)	TO (OUTPUT)	TEST CONDITIONS	MIN	TYP†	MAX	UNIT
f <sub>max</sub>	CLKA		C <sub>L</sub> = 30 pF	10	20		MHz
	CLKB			10	20		
	UNCK IN			10	20		
t <sub>w</sub>	UNCK OUT		C <sub>L</sub> = 30 pF	7	14		ns
t <sub>dis</sub>	OE	Any Q	C <sub>L</sub> = 5 pF		10	25	ns
t <sub>en</sub>	OE	Any Q	C <sub>L</sub> = 30 pF		25	40	ns
t <sub>PLH</sub>	UNCK IN	Any Q	C <sub>L</sub> = 30 pF		50	75	ns
t <sub>PHL</sub>					50	75	
t <sub>PLH</sub>	CLKA or CLKB	OR	C <sub>L</sub> = 30 pF		190	300	ns
t <sub>PLH</sub>	UNCK IN	OR	C <sub>L</sub> = 30 pF		40	60	ns
t <sub>PHL</sub>					30	45	
t <sub>PHL</sub>	CLR	OR	C <sub>L</sub> = 30 pF		35	60	ns
	CLKA or CLKB	UNCK OUT			25	45	
	UNCK IN				270	400	
	CLKA or CLKB	IR			55	75	
t <sub>PLH</sub>	UNCK IN	IR	C <sub>L</sub> = 30 pF		255	400	ns
	CLR				16	35	
	OR↑			Any Q		10	

† All typical values are at V<sub>CC</sub> = 5 V, T<sub>A</sub> = 25°C.

**PARAMETER MEASUREMENT INFORMATION**

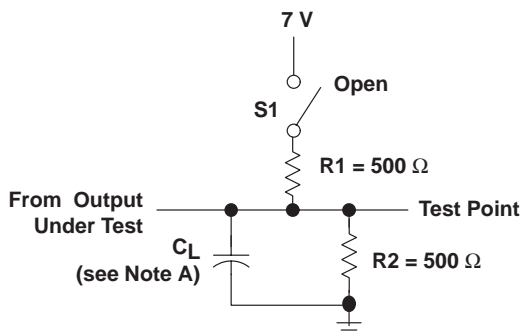

**LOAD CIRCUIT FOR 3-STATE OUTPUTS**

PARAMETER	S1	
$t_{en}$	$t_{PZH}$	Open
	$t_{PZL}$	Closed
$t_{dis}$	$t_{PHZ}$	Open
	$t_{PLZ}$	Closed
$t_{pd}$	$t_{PLH}$	Open
	$t_{PHL}$	Open

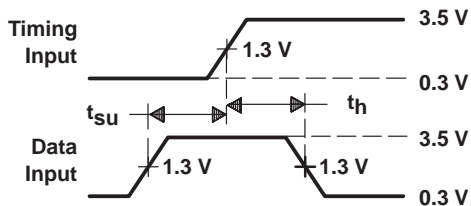

**VOLTAGE WAVEFORMS  
SET UP AND HOLD TIMES**

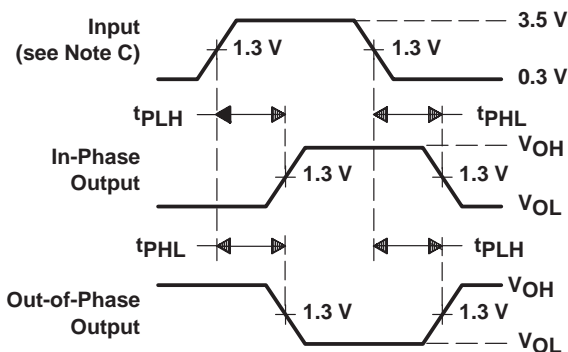

**VOLTAGE WAVEFORMS  
PROPAGATION DELAY TIMES**

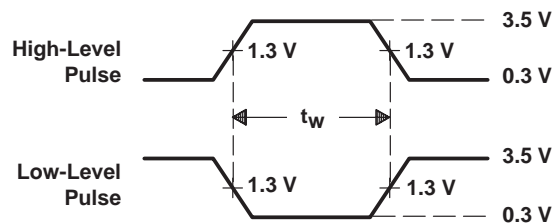

**VOLTAGE WAVEFORMS  
PULSE DURATION**

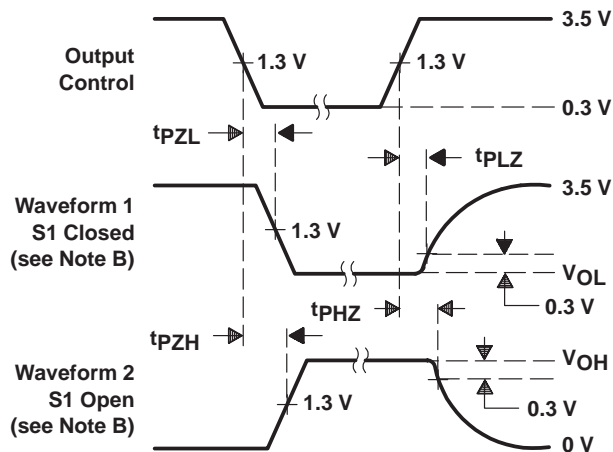

**VOLTAGE WAVEFORMS  
ENABLE AND DISABLE TIMES, 3-STATE OUTPUTS**

- NOTES: A.  $C_L$  includes probe and jig capacitance.  
 B. Waveform 1 is for an output with internal conditions such that the output is low except when disabled by the output control. Waveform 2 is for an output with internal conditions such that the output is high except when disabled by the output control.  
 C. All input pulses are supplied by generators having the following characteristics:  $PRR \leq 1$  MHz,  $Z_O = 50 \Omega$ ,  $t_r \leq 2$  ns,  $t_f \leq 2$  ns.  
 D. The outputs are measured one at a time with one transition per measurement.

**Figure 1. Load Circuit and Voltage Waveforms**

**SN74S225**  
**16 × 5 ASYNCHRONOUS FIRST-IN, FIRST-OUT MEMORY**  
**WITH 3-STATE OUTPUTS**

SDLS207B – SEPTEMBER 1976 – REVISED APRIL 1998

**APPLICATION INFORMATION**

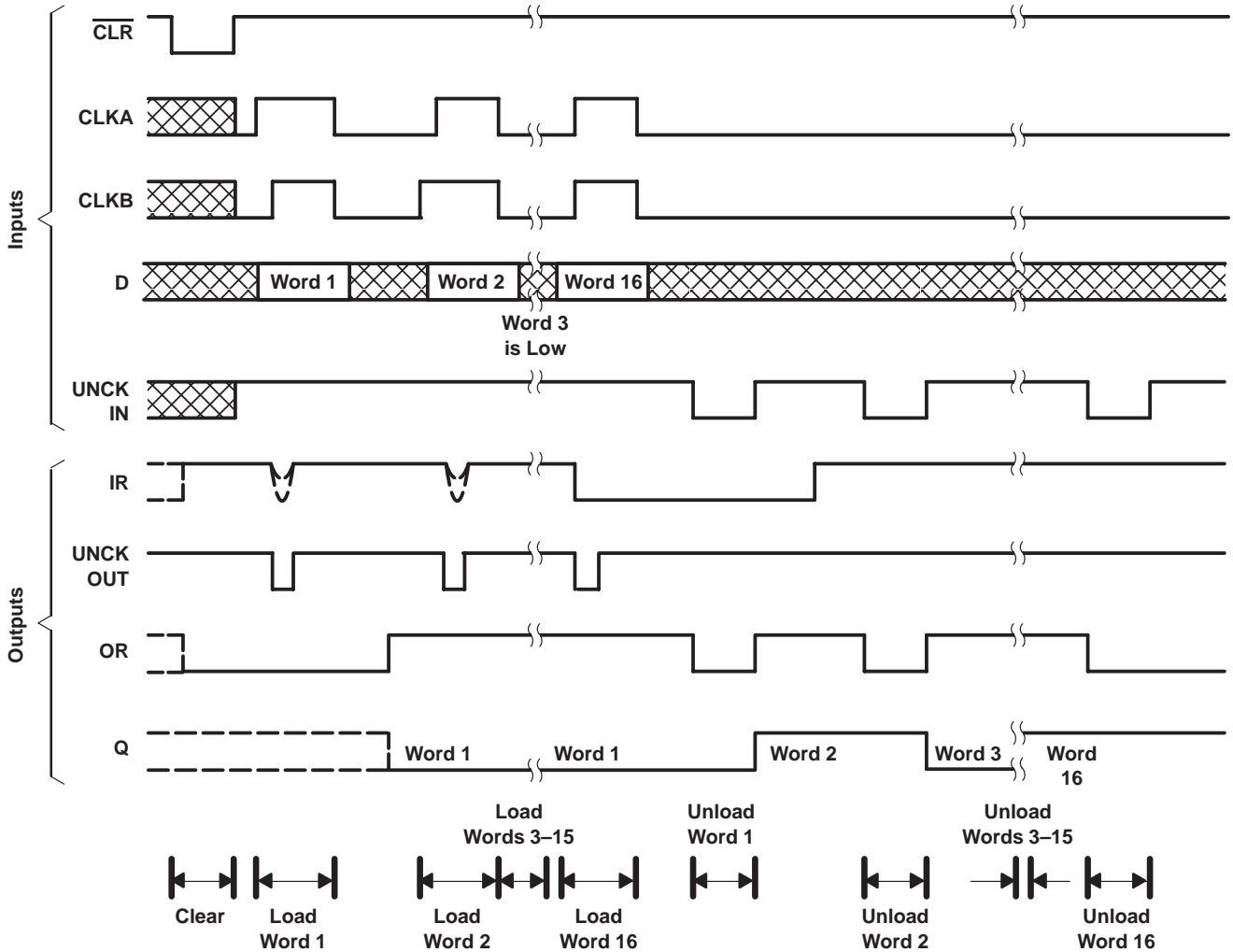

**Figure 2. Typical Waveforms for a 16-Word FIFO**



**PACKAGING INFORMATION**

Orderable Device	Status <sup>(1)</sup>	Package Type	Package Drawing	Pins	Package Qty	Eco Plan <sup>(2)</sup>	Lead/Ball Finish	MSL Peak Temp <sup>(3)</sup>
SN74S225J	OBSOLETE	CDIP	J	20		TBD	Call TI	Call TI
SN74S225N	ACTIVE	PDIP	N	20	20	Pb-Free (RoHS)	CU NIPDAU	N / A for Pkg Type
SN74S225N3	OBSOLETE	PDIP	N	20		TBD	Call TI	Call TI

<sup>(1)</sup> The marketing status values are defined as follows:

**ACTIVE:** Product device recommended for new designs.

**LIFEBUY:** TI has announced that the device will be discontinued, and a lifetime-buy period is in effect.

**NRND:** Not recommended for new designs. Device is in production to support existing customers, but TI does not recommend using this part in a new design.

**PREVIEW:** Device has been announced but is not in production. Samples may or may not be available.

**OBSOLETE:** TI has discontinued the production of the device.

<sup>(2)</sup> Eco Plan - The planned eco-friendly classification: Pb-Free (RoHS), Pb-Free (RoHS Exempt), or Green (RoHS & no Sb/Br) - please check <http://www.ti.com/productcontent> for the latest availability information and additional product content details.

**TBD:** The Pb-Free/Green conversion plan has not been defined.

**Pb-Free (RoHS):** TI's terms "Lead-Free" or "Pb-Free" mean semiconductor products that are compatible with the current RoHS requirements for all 6 substances, including the requirement that lead not exceed 0.1% by weight in homogeneous materials. Where designed to be soldered at high temperatures, TI Pb-Free products are suitable for use in specified lead-free processes.

**Pb-Free (RoHS Exempt):** This component has a RoHS exemption for either 1) lead-based flip-chip solder bumps used between the die and package, or 2) lead-based die adhesive used between the die and leadframe. The component is otherwise considered Pb-Free (RoHS compatible) as defined above.

**Green (RoHS & no Sb/Br):** TI defines "Green" to mean Pb-Free (RoHS compatible), and free of Bromine (Br) and Antimony (Sb) based flame retardants (Br or Sb do not exceed 0.1% by weight in homogeneous material)

<sup>(3)</sup> MSL, Peak Temp. -- The Moisture Sensitivity Level rating according to the JEDEC industry standard classifications, and peak solder temperature.

**Important Information and Disclaimer:**The information provided on this page represents TI's knowledge and belief as of the date that it is provided. TI bases its knowledge and belief on information provided by third parties, and makes no representation or warranty as to the accuracy of such information. Efforts are underway to better integrate information from third parties. TI has taken and continues to take reasonable steps to provide representative and accurate information but may not have conducted destructive testing or chemical analysis on incoming materials and chemicals. TI and TI suppliers consider certain information to be proprietary, and thus CAS numbers and other limited information may not be available for release.

In no event shall TI's liability arising out of such information exceed the total purchase price of the TI part(s) at issue in this document sold by TI to Customer on an annual basis.

J (R-GDIP-T\*\*)   
 14 LEADS SHOWN

CERAMIC DUAL IN-LINE PACKAGE

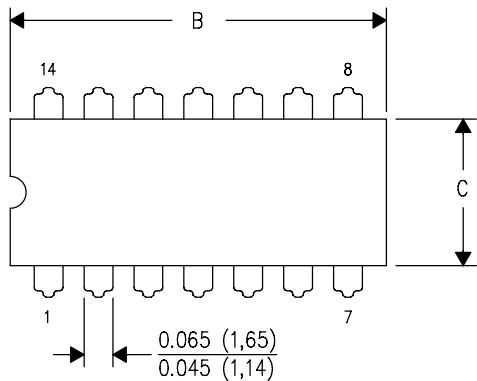

DIM \ PINS **	14	16	18	20
A	0.300 (7,62) BSC	0.300 (7,62) BSC	0.300 (7,62) BSC	0.300 (7,62) BSC
B MAX	0.785 (19,94)	.840 (21,34)	0.960 (24,38)	1.060 (26,92)
B MIN	—	—	—	—
C MAX	0.300 (7,62)	0.300 (7,62)	0.310 (7,87)	0.300 (7,62)
C MIN	0.245 (6,22)	0.245 (6,22)	0.220 (5,59)	0.245 (6,22)

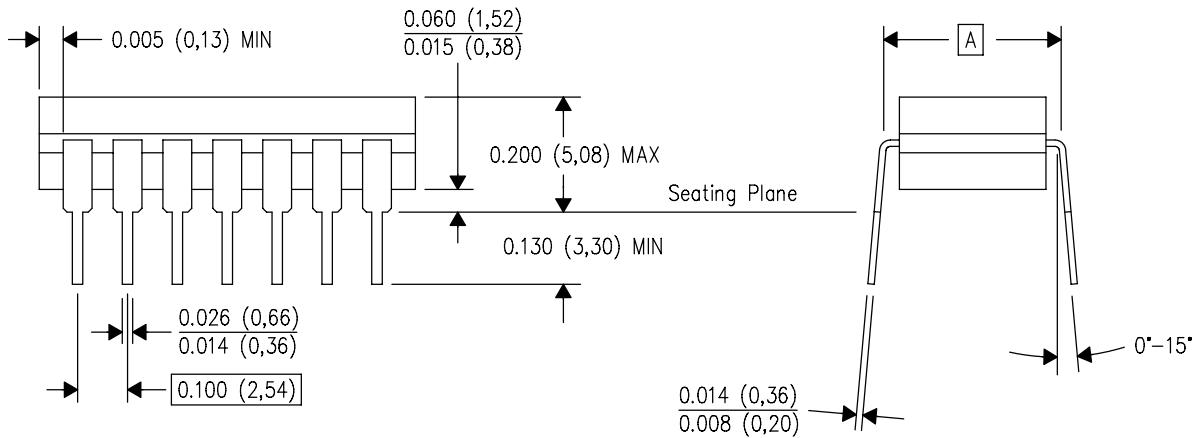

4040083/F 03/03

- NOTES:
- A. All linear dimensions are in inches (millimeters).
  - B. This drawing is subject to change without notice.
  - C. This package is hermetically sealed with a ceramic lid using glass frit.
  - D. Index point is provided on cap for terminal identification only on press ceramic glass frit seal only.
  - E. Falls within MIL STD 1835 GDIP1-T14, GDIP1-T16, GDIP1-T18 and GDIP1-T20.

N (R-PDIP-T\*\*)

PLASTIC DUAL-IN-LINE PACKAGE

16 PINS SHOWN



- NOTES:
- A. All linear dimensions are in inches (millimeters).
  - B. This drawing is subject to change without notice.
  - $\triangle C$  Falls within JEDEC MS-001, except 18 and 20 pin minimum body length (Dim A).
  - $\triangle D$  The 20 pin end lead shoulder width is a vendor option, either half or full width.

4040049/E 12/2002

## IMPORTANT NOTICE

Texas Instruments Incorporated and its subsidiaries (TI) reserve the right to make corrections, modifications, enhancements, improvements, and other changes to its products and services at any time and to discontinue any product or service without notice. Customers should obtain the latest relevant information before placing orders and should verify that such information is current and complete. All products are sold subject to TI's terms and conditions of sale supplied at the time of order acknowledgment.

TI warrants performance of its hardware products to the specifications applicable at the time of sale in accordance with TI's standard warranty. Testing and other quality control techniques are used to the extent TI deems necessary to support this warranty. Except where mandated by government requirements, testing of all parameters of each product is not necessarily performed.

TI assumes no liability for applications assistance or customer product design. Customers are responsible for their products and applications using TI components. To minimize the risks associated with customer products and applications, customers should provide adequate design and operating safeguards.

TI does not warrant or represent that any license, either express or implied, is granted under any TI patent right, copyright, mask work right, or other TI intellectual property right relating to any combination, machine, or process in which TI products or services are used. Information published by TI regarding third-party products or services does not constitute a license from TI to use such products or services or a warranty or endorsement thereof. Use of such information may require a license from a third party under the patents or other intellectual property of the third party, or a license from TI under the patents or other intellectual property of TI.

Reproduction of information in TI data books or data sheets is permissible only if reproduction is without alteration and is accompanied by all associated warranties, conditions, limitations, and notices. Reproduction of this information with alteration is an unfair and deceptive business practice. TI is not responsible or liable for such altered documentation.

Resale of TI products or services with statements different from or beyond the parameters stated by TI for that product or service voids all express and any implied warranties for the associated TI product or service and is an unfair and deceptive business practice. TI is not responsible or liable for any such statements.

Following are URLs where you can obtain information on other Texas Instruments products and application solutions:

<b>Products</b>		<b>Applications</b>	
Amplifiers	<a href="http://amplifier.ti.com">amplifier.ti.com</a>	Audio	<a href="http://www.ti.com/audio">www.ti.com/audio</a>
Data Converters	<a href="http://dataconverter.ti.com">dataconverter.ti.com</a>	Automotive	<a href="http://www.ti.com/automotive">www.ti.com/automotive</a>
DSP	<a href="http://dsp.ti.com">dsp.ti.com</a>	Broadband	<a href="http://www.ti.com/broadband">www.ti.com/broadband</a>
Interface	<a href="http://interface.ti.com">interface.ti.com</a>	Digital Control	<a href="http://www.ti.com/digitalcontrol">www.ti.com/digitalcontrol</a>
Logic	<a href="http://logic.ti.com">logic.ti.com</a>	Military	<a href="http://www.ti.com/military">www.ti.com/military</a>
Power Mgmt	<a href="http://power.ti.com">power.ti.com</a>	Optical Networking	<a href="http://www.ti.com/opticalnetwork">www.ti.com/opticalnetwork</a>
Microcontrollers	<a href="http://microcontroller.ti.com">microcontroller.ti.com</a>	Security	<a href="http://www.ti.com/security">www.ti.com/security</a>
Low Power Wireless	<a href="http://www.ti.com/lpw">www.ti.com/lpw</a>	Telephony	<a href="http://www.ti.com/telephony">www.ti.com/telephony</a>
		Video & Imaging	<a href="http://www.ti.com/video">www.ti.com/video</a>
		Wireless	<a href="http://www.ti.com/wireless">www.ti.com/wireless</a>

Mailing Address: Texas Instruments  
Post Office Box 655303 Dallas, Texas 75265