

SN54S124, SN74S124 DUAL VOLTAGE-CONTROLLED OSCILLATORS

SDLS201A – DECEMBER 1983 – REVISED APRIL 2004

- Two independent VCOs in a 16-Pin Package
- Output Frequency Set by Single External Component:
Capacitor for Fixed- or Variable-Frequency Operation
- Separate Supply Voltage Pins for Isolation of Frequency Control Inputs and Oscillators from Output Circuitry
- Highly Stable Operation over Specified Temperature and/or Supply Voltage Ranges
- Typical f_{max} 85 MHz
Typical Power Dissipation 525 mW
- Frequency Spectrum . . . 1 Hz to 60 MHz

description

The 'S124 features two independent voltage-controlled oscillators (VCO) in a single monolithic chip. The output frequency of each VCO is established by an external capacitor in combination with two voltage-sensitive inputs, one for frequency range and one for frequency control. These inputs can be used to vary the output frequency as shown under typical characteristics. These highly stable oscillators can be set to operate at any frequency typically between 0.12 hertz and 85 megahertz. 1

SN54S124 . . . J OR W PACKAGE
SN74S124 . . . D OR N PACKAGE
(TOP VIEW)

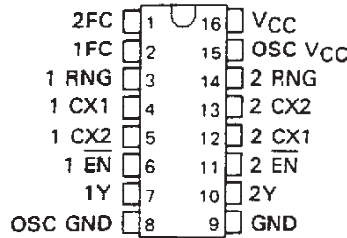

SN54S124 . . . FK PACKAGE
(TOP VIEW)

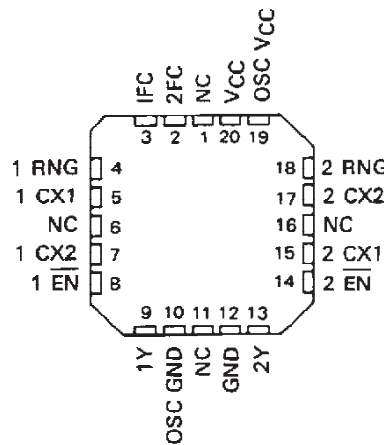

NC – No internal connection

While the enable input is low, the output is enabled.
While the enable input is high, the output is high.

These devices can operate from a single 5-volt supply. However, one set of supply-voltage and ground pins (V_{CC} and GND) is provided for the enable, synchronization-gating, and output sections, and a separate set ($\ominus V_{CC}$ and $\ominus GND$) is provided for the oscillator and associated frequency-control circuits so that effective isolation can be accomplished in the system.

The enable input of these devices starts or stops the output pulses when it is low or high, respectively. The internal oscillator of the 'S124 is started and stopped by the enable input. The enable input is one standard load; it and the buffered output operate at standard Schottky-clamped TTL levels.

The pulse synchronization-gating section ensures that the first output pulse is neither clipped nor extended. Duty cycle of the square-wave output is fixed at approximately 50 percent.

The SN54S124 is characterized for operation over the full military temperature range of -55°C to 125°C ; the SN74S124 is characterized for operation from 0°C to 70°C .



Please be aware that an important notice concerning availability, standard warranty, and use in critical applications of Texas Instruments semiconductor products and disclaimers thereto appears at the end of this data sheet.

PRODUCTION DATA information is current as of publication date. Products conform to specifications per the terms of Texas Instruments standard warranty. Production processing does not necessarily include testing of all parameters.



POST OFFICE BOX 655303 • DALLAS, TEXAS 75265

Copyright © 2004, Texas Instruments Incorporated

SN54S124, SN74S124 DUAL VOLTAGE-CONTROLLED OSCILLATORS

SDLS201A – DECEMBER 1983 – REVISED APRIL 2004

logic symbol†

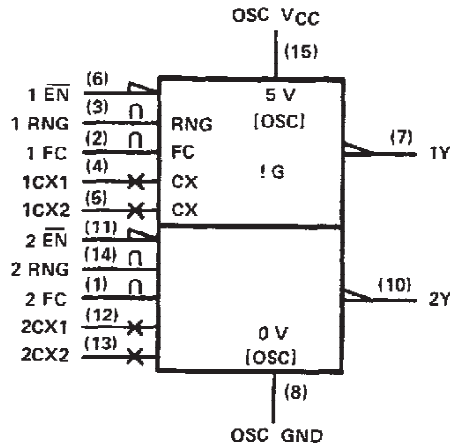

†This symbol is in accordance with ANSI/IEEE Std 91-1984 and IEC Publication 617-12. Pin numbers shown are for D, J, N, and W packages.

schematics of inputs and outputs

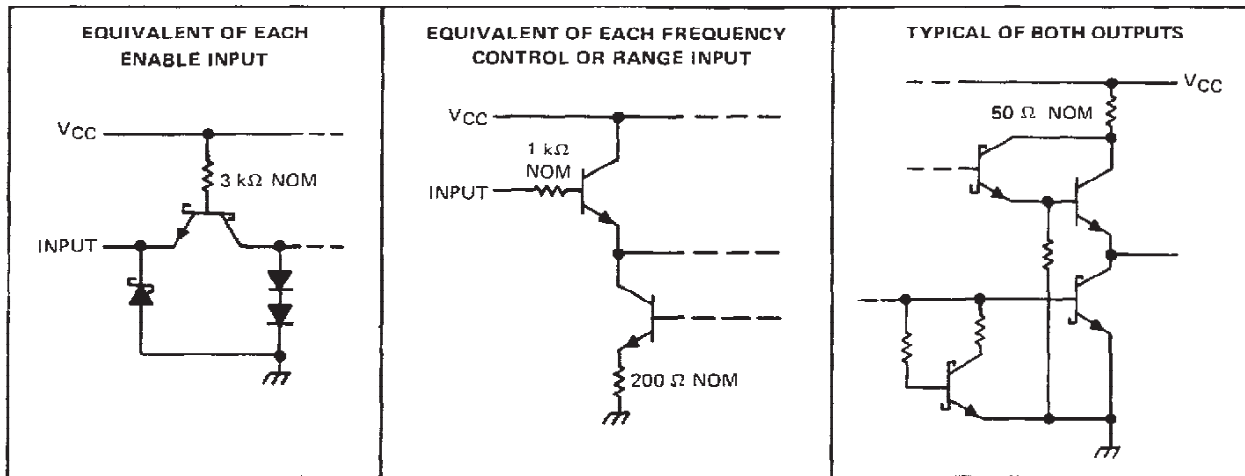

absolute maximum ratings over operating free-air temperature range (unless otherwise noted)

Supply voltage, V_{CC} (See Notes 1 and 2)	7V
Input voltage	5.5 V
Operating free-air temperature range: SN54S124	-55°C to 125°C
SN74S124	0°C to 70°C
Storage temperature range	-65°C to 150°C

NOTES: 1. Voltage values are with respect to the appropriate ground terminal.

2. Throughout this data sheet, the symbol V_{CC} is used for the voltage applied to both the V_{CC} and $\odot V_{CC}$ terminals, unless otherwise noted.

SN54S124, SN74S124 DUAL VOLTAGE-CONTROLLED OSCILLATORS

SDLS201A – DECEMBER 1983 – REVISED APRIL 2004

recommended operating conditions

	SN54S124			SN74S124			UNIT
	MIN	NOM	MAX	MIN	NOM	MAX	
Supply voltage, V_{CC} (see Note 1)	4.5	5	5.5	4.75	5	6.25	V
Input voltage at frequency control or range input, $V_I(\text{freq})$ or $V_I(\text{rng})$	1		5	1		5	V
High-level output current, I_{OH}			-1			-1	mA
Low-level output current, I_{OL}			20			20	mA
Output frequency (enabled), f_o	1			1			Hz
			60			60	MHz
Operating free-air temperature, T_A	-55		125	0		70	$^{\circ}\text{C}$

electrical characteristics over recommended operating free-air temperature range (unless otherwise noted)

PARAMETER		TEST CONDITIONS†	MIN	TYP‡	MAX	UNIT	
V_{IH}	High-level input voltage at enable		2			V	
V_{IL}	Low-level input voltage at enable				0.8	V	
V_{IK}	Input clamp voltage at enable	$V_{CC} = \text{MIN}, I_I = -18 \text{ mA}$			-1.2	V	
V_{OH}	High-level output voltage	$V_{CC} = \text{MIN}, V_{IH} = 2 \text{ V}, I_{OH} = -1 \text{ mA}$	SN54S'	2.5	3.4	V	
			SN74S'	2.7	3.4		
V_{OL}	Low-level output voltage	$V_{CC} = \text{MIN}, V_{IL} = 0.8 \text{ V}, I_{OL} = 20 \text{ mA}$			0.5	V	
I_I	Input current	Freq control or range	$V_{CC} = \text{MAX}$	$V_I = 5 \text{ V}$	10	50	μA
				$V_I = 1 \text{ V}$	1	15	
I_I	Input current at maximum input voltage	Enable	$V_{CC} = \text{MAX}, V_I = 5.5 \text{ V}$		1	mA	
I_{IH}	High-level input current	Enable	$V_{CC} = \text{MAX}, V_I = 2.7 \text{ V}$		50	μA	
I_{IL}	Low-level input current	Enable	$V_{CC} = \text{MAX}, V_I = 0.5 \text{ V}$		-2	mA	
I_{OS}	Short-circuit output current §	$V_{CC} = \text{MAX}$	-40		-100	mA	
I_{CC}	Supply current, total into V_{CC} and $\ominus V_{CC}$	$V_{CC} = \text{MAX}, \text{ See Note 3}$		105	150	mA	
		$V_{CC} = \text{MAX}, T_A = 125^{\circ}\text{C}, \text{ W package only}$ See Note 3			110		

†For conditions shown as MIN or MAX, use the appropriate value specified under recommended operating conditions.

‡All typical values are at $V_{CC} = 5 \text{ V}, T_A = 25^{\circ}\text{C}$.

§Not more than one output should be shorted at a time and duration of the short-circuit should not exceed one second.

NOTE 3: I_{CC} is measured with the outputs disabled and open.

switching characteristics, $V_{CC} = 5 \text{ V}, R_L = 280 \Omega, C_L = 15 \text{ pF}, T_A = 25^{\circ}\text{C}$ (see note 4)

PARAMETER		TEST CONDITIONS	MIN	TYP	MAX	UNIT
f_o	Output frequency	$C_{\text{ext}} = 2 \text{ pF}$	$V_I(\text{freq}) = 4 \text{ V}, V_I(\text{rng}) = 1 \text{ V}$	60	85	MHz
			$V_I(\text{freq}) = 1 \text{ V}, V_I(\text{rng}) = 5 \text{ V}$	25	40	
	Output duty cycle	$C_{\text{ext}} = 8.3 \text{ pF}$ to $500 \mu\text{F}$		50%		
t_{PHL}	Propagation delay time, high-to-low-level output from enable	$f_o = 1 \text{ Hz}$ to 20 MHz		$\frac{1.4}{f_o(\text{Hz})}$		s
		$f_o > 20 \text{ MHz}$		70		ns

NOTE 4: Load circuits and voltage waveforms are shown in Section 1.



SN54S124, SN74S124 DUAL VOLTAGE-CONTROLLED OSCILLATORS

SDLS201A - DECEMBER 1983 - REVISED APRIL 2004

TYPICAL CHARACTERISTICS

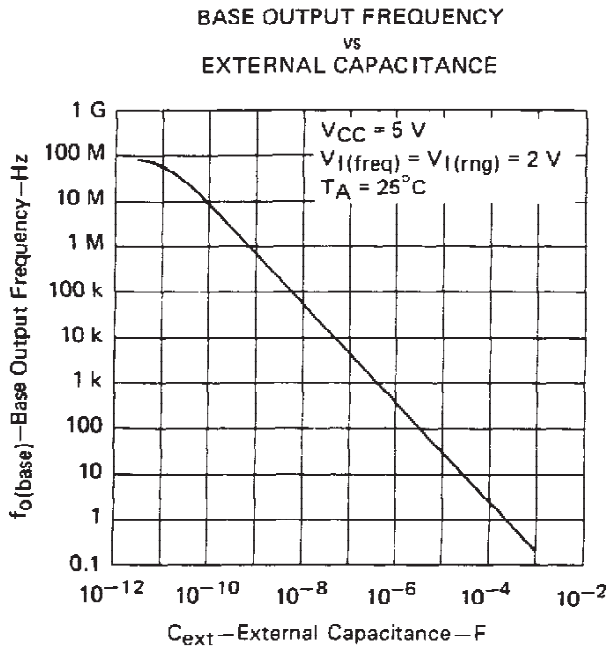

FIGURE 1

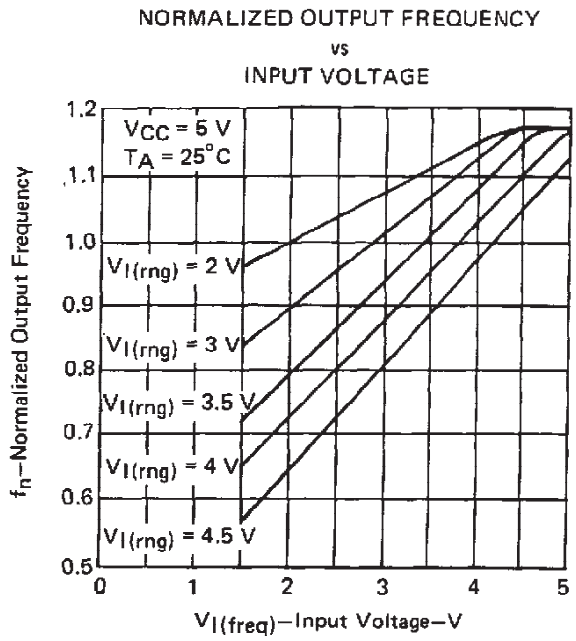

FIGURE 2

NOTE: $f_o = f_n \times f_{o(\text{base})}$

IMPORTANT NOTICE

Texas Instruments Incorporated and its subsidiaries (TI) reserve the right to make corrections, modifications, enhancements, improvements, and other changes to its products and services at any time and to discontinue any product or service without notice. Customers should obtain the latest relevant information before placing orders and should verify that such information is current and complete. All products are sold subject to TI's terms and conditions of sale supplied at the time of order acknowledgment.

TI warrants performance of its hardware products to the specifications applicable at the time of sale in accordance with TI's standard warranty. Testing and other quality control techniques are used to the extent TI deems necessary to support this warranty. Except where mandated by government requirements, testing of all parameters of each product is not necessarily performed.

TI assumes no liability for applications assistance or customer product design. Customers are responsible for their products and applications using TI components. To minimize the risks associated with customer products and applications, customers should provide adequate design and operating safeguards.

TI does not warrant or represent that any license, either express or implied, is granted under any TI patent right, copyright, mask work right, or other TI intellectual property right relating to any combination, machine, or process in which TI products or services are used. Information published by TI regarding third-party products or services does not constitute a license from TI to use such products or services or a warranty or endorsement thereof. Use of such information may require a license from a third party under the patents or other intellectual property of the third party, or a license from TI under the patents or other intellectual property of TI.

Reproduction of information in TI data books or data sheets is permissible only if reproduction is without alteration and is accompanied by all associated warranties, conditions, limitations, and notices. Reproduction of this information with alteration is an unfair and deceptive business practice. TI is not responsible or liable for such altered documentation.

Resale of TI products or services with statements different from or beyond the parameters stated by TI for that product or service voids all express and any implied warranties for the associated TI product or service and is an unfair and deceptive business practice. TI is not responsible or liable for any such statements.

TI products are not authorized for use in safety-critical applications (such as life support) where a failure of the TI product would reasonably be expected to cause severe personal injury or death, unless officers of the parties have executed an agreement specifically governing such use. Buyers represent that they have all necessary expertise in the safety and regulatory ramifications of their applications, and acknowledge and agree that they are solely responsible for all legal, regulatory and safety-related requirements concerning their products and any use of TI products in such safety-critical applications, notwithstanding any applications-related information or support that may be provided by TI. Further, Buyers must fully indemnify TI and its representatives against any damages arising out of the use of TI products in such safety-critical applications.

TI products are neither designed nor intended for use in military/aerospace applications or environments unless the TI products are specifically designated by TI as military-grade or "enhanced plastic." Only products designated by TI as military-grade meet military specifications. Buyers acknowledge and agree that any such use of TI products which TI has not designated as military-grade is solely at the Buyer's risk, and that they are solely responsible for compliance with all legal and regulatory requirements in connection with such use.

TI products are neither designed nor intended for use in automotive applications or environments unless the specific TI products are designated by TI as compliant with ISO/TS 16949 requirements. Buyers acknowledge and agree that, if they use any non-designated products in automotive applications, TI will not be responsible for any failure to meet such requirements.

Following are URLs where you can obtain information on other Texas Instruments products and application solutions:

Products		Applications	
Amplifiers	amplifier.ti.com	Audio	www.ti.com/audio
Data Converters	dataconverter.ti.com	Automotive	www.ti.com/automotive
DSP	dsp.ti.com	Broadband	www.ti.com/broadband
Interface	interface.ti.com	Digital Control	www.ti.com/digitalcontrol
Logic	logic.ti.com	Military	www.ti.com/military
Power Mgmt	power.ti.com	Optical Networking	www.ti.com/opticalnetwork
Microcontrollers	microcontroller.ti.com	Security	www.ti.com/security
Low Power Wireless	www.ti.com/lpw	Telephony	www.ti.com/telephony
		Video & Imaging	www.ti.com/video
		Wireless	www.ti.com/wireless

Mailing Address: Texas Instruments, Post Office Box 655303, Dallas, Texas 75265
Copyright © 2007, Texas Instruments Incorporated

PACKAGING INFORMATION

Orderable Device	Status ⁽¹⁾	Package Type	Package Drawing	Pins	Package Qty	Eco Plan ⁽²⁾	Lead/Ball Finish	MSL Peak Temp ⁽³⁾
SN54S124J	ACTIVE	CDIP	J	16	1	TBD	A42	N / A for Pkg Type
SN74S124D	ACTIVE	SOIC	D	16	40	Green (RoHS & no Sb/Br)	CU NIPDAU	Level-1-260C-UNLIM
SN74S124DE4	ACTIVE	SOIC	D	16	40	Green (RoHS & no Sb/Br)	CU NIPDAU	Level-1-260C-UNLIM
SN74S124DG4	ACTIVE	SOIC	D	16	40	Green (RoHS & no Sb/Br)	CU NIPDAU	Level-1-260C-UNLIM
SN74S124DRE4	ACTIVE	SOIC	D	16		TBD	Call TI	Call TI
SN74S124DRG4	ACTIVE	SOIC	D	16		TBD	Call TI	Call TI
SN74S124N	ACTIVE	PDIP	N	16	25	Pb-Free (RoHS)	CU NIPDAU	N / A for Pkg Type
SN74S124N3	OBSOLETE	PDIP	N	16		TBD	Call TI	Call TI
SN74S124NE4	ACTIVE	PDIP	N	16	25	Pb-Free (RoHS)	CU NIPDAU	N / A for Pkg Type
SNJ54S124J	ACTIVE	CDIP	J	16	1	TBD	A42	N / A for Pkg Type
SNJ54S124W	ACTIVE	CFP	W	16	1	TBD	A42	N / A for Pkg Type

⁽¹⁾ The marketing status values are defined as follows:

ACTIVE: Product device recommended for new designs.

LIFEBUY: TI has announced that the device will be discontinued, and a lifetime-buy period is in effect.

NRND: Not recommended for new designs. Device is in production to support existing customers, but TI does not recommend using this part in a new design.

PREVIEW: Device has been announced but is not in production. Samples may or may not be available.

OBSOLETE: TI has discontinued the production of the device.

⁽²⁾ Eco Plan - The planned eco-friendly classification: Pb-Free (RoHS), Pb-Free (RoHS Exempt), or Green (RoHS & no Sb/Br) - please check <http://www.ti.com/productcontent> for the latest availability information and additional product content details.

TBD: The Pb-Free/Green conversion plan has not been defined.

Pb-Free (RoHS): TI's terms "Lead-Free" or "Pb-Free" mean semiconductor products that are compatible with the current RoHS requirements for all 6 substances, including the requirement that lead not exceed 0.1% by weight in homogeneous materials. Where designed to be soldered at high temperatures, TI Pb-Free products are suitable for use in specified lead-free processes.

Pb-Free (RoHS Exempt): This component has a RoHS exemption for either 1) lead-based flip-chip solder bumps used between the die and package, or 2) lead-based die adhesive used between the die and leadframe. The component is otherwise considered Pb-Free (RoHS compatible) as defined above.

Green (RoHS & no Sb/Br): TI defines "Green" to mean Pb-Free (RoHS compatible), and free of Bromine (Br) and Antimony (Sb) based flame retardants (Br or Sb do not exceed 0.1% by weight in homogeneous material)

⁽³⁾ MSL, Peak Temp. -- The Moisture Sensitivity Level rating according to the JEDEC industry standard classifications, and peak solder temperature.

Important Information and Disclaimer:The information provided on this page represents TI's knowledge and belief as of the date that it is provided. TI bases its knowledge and belief on information provided by third parties, and makes no representation or warranty as to the accuracy of such information. Efforts are underway to better integrate information from third parties. TI has taken and continues to take reasonable steps to provide representative and accurate information but may not have conducted destructive testing or chemical analysis on incoming materials and chemicals. TI and TI suppliers consider certain information to be proprietary, and thus CAS numbers and other limited information may not be available for release.

In no event shall TI's liability arising out of such information exceed the total purchase price of the TI part(s) at issue in this document sold by TI to Customer on an annual basis.

J (R-GDIP-T**)

14 LEADS SHOWN

CERAMIC DUAL IN-LINE PACKAGE



DIM \ PINS **	14	16	18	20
A	0.300 (7,62) BSC	0.300 (7,62) BSC	0.300 (7,62) BSC	0.300 (7,62) BSC
B MAX	0.785 (19,94)	.840 (21,34)	0.960 (24,38)	1.060 (26,92)
B MIN	—	—	—	—
C MAX	0.300 (7,62)	0.300 (7,62)	0.310 (7,87)	0.300 (7,62)
C MIN	0.245 (6,22)	0.245 (6,22)	0.220 (5,59)	0.245 (6,22)



4040083/F 03/03

- NOTES:
- All linear dimensions are in inches (millimeters).
 - This drawing is subject to change without notice.
 - This package is hermetically sealed with a ceramic lid using glass frit.
 - Index point is provided on cap for terminal identification only on press ceramic glass frit seal only.
 - Falls within MIL STD 1835 GDIP1-T14, GDIP1-T16, GDIP1-T18 and GDIP1-T20.

W (R-GDFP-F16)

CERAMIC DUAL FLATPACK

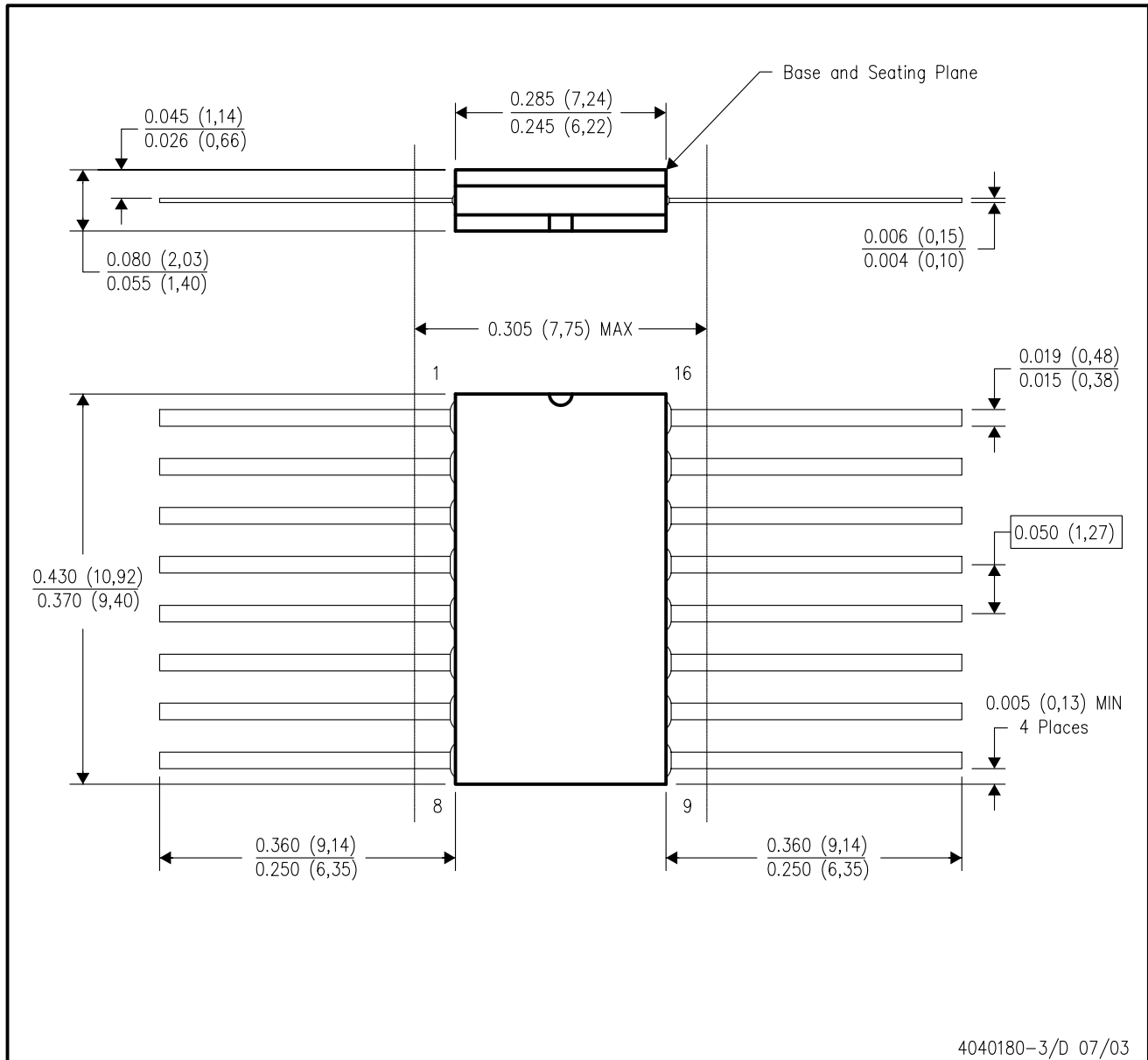



- NOTES:
- A. All linear dimensions are in inches (millimeters).
 - B. This drawing is subject to change without notice.
 - C. This package can be hermetically sealed with a ceramic lid using glass frit.
 - D. Index point is provided on cap for terminal identification only.
 - E. Falls within MIL STD 1835 GDFP1-F16 and JEDEC MO-092AC

D (R-PDSO-G16)

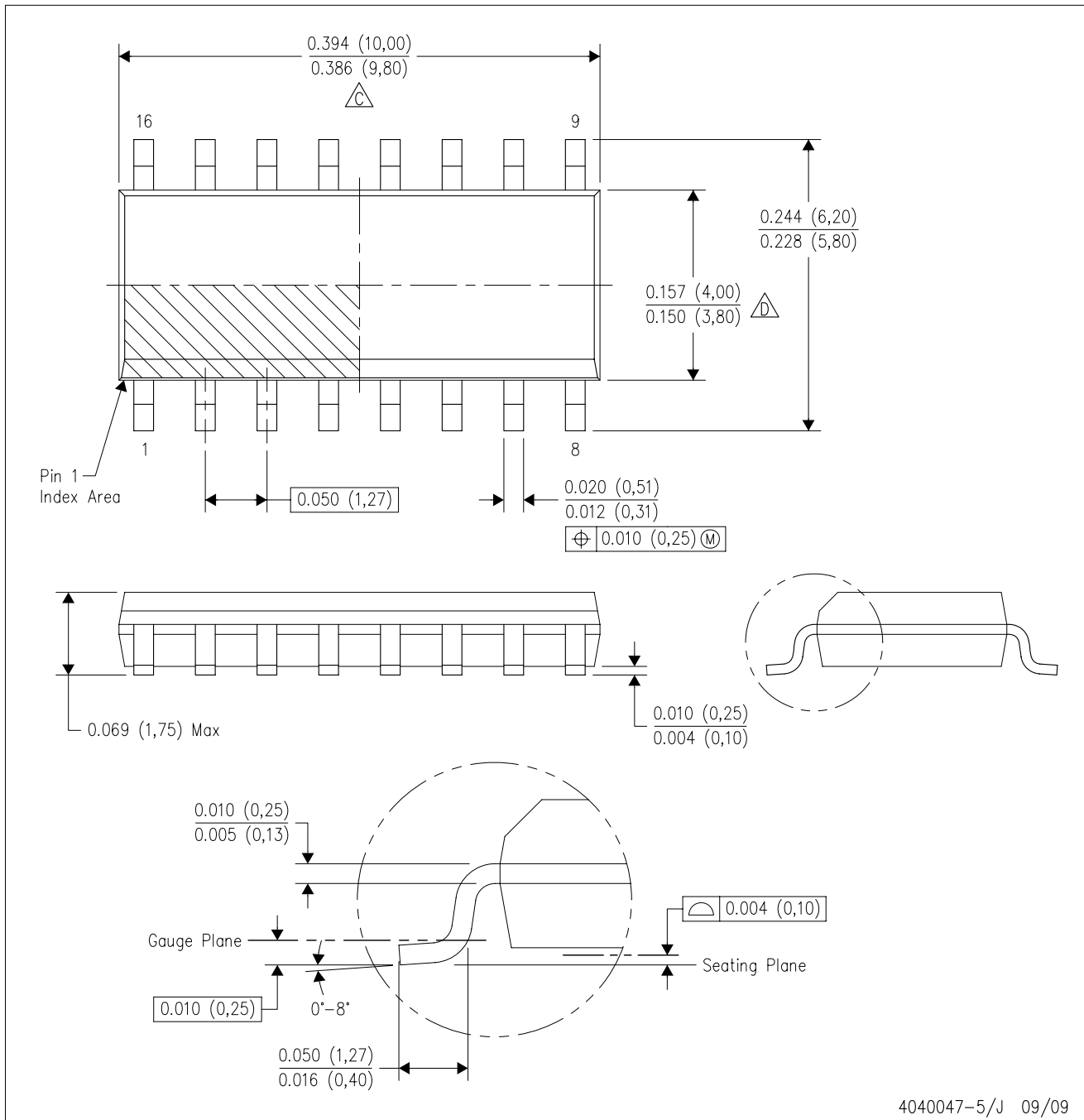
PLASTIC SMALL-OUTLINE PACKAGE



4040047-5/J 09/09

- NOTES:
- A. All linear dimensions are in inches (millimeters).
 - B. This drawing is subject to change without notice.
 -  C. Body length does not include mold flash, protrusions, or gate burrs. Mold flash, protrusions, or gate burrs shall not exceed .006 (0,15) per end.
 -  D. Body width does not include interlead flash. Interlead flash shall not exceed .017 (0,43) per side.
 - E. Reference JEDEC MS-012 variation AC.

D(R-PDSO-G16)

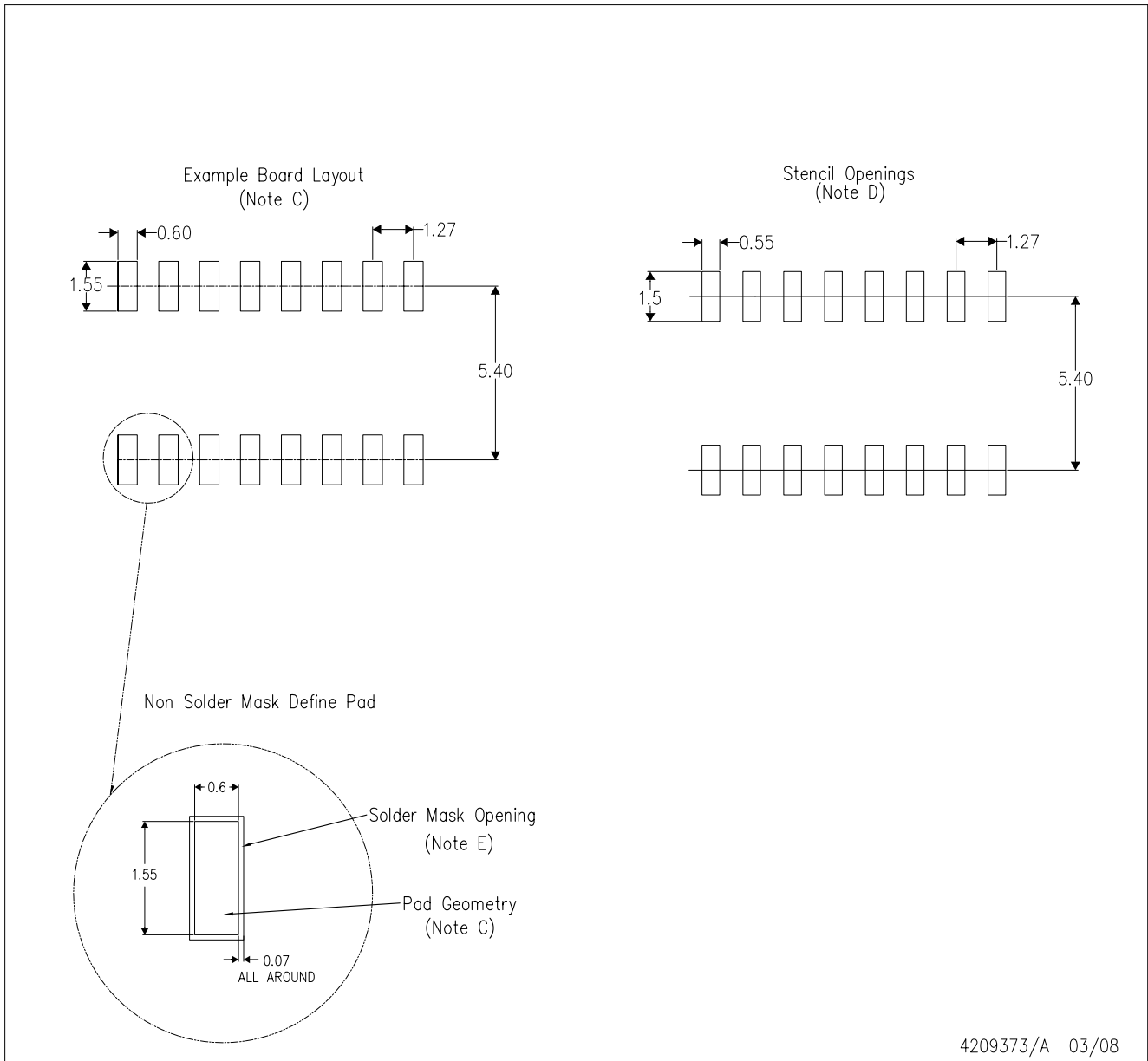

- NOTES:
- A. All linear dimensions are in millimeters.
 - B. This drawing is subject to change without notice.
 - C. Refer to IPC7351 for alternate board design.
 - D. Laser cutting apertures with trapezoidal walls and also rounding corners will offer better paste release. Customers should contact their board assembly site for stencil design recommendations. Refer to IPC-7525
 - E. Customers should contact their board fabrication site for solder mask tolerances between and around signal pads.

N (R-PDIP-T**)

PLASTIC DUAL-IN-LINE PACKAGE

16 PINS SHOWN



- NOTES:
- A. All linear dimensions are in inches (millimeters).
 - B. This drawing is subject to change without notice.
 - Falls within JEDEC MS-001, except 18 and 20 pin minimum body length (Dim A).
 - The 20 pin end lead shoulder width is a vendor option, either half or full width.