

# SN54LVTH652, SN74LVTH652 3.3-V ABT OCTAL BUS TRANSCEIVERS AND REGISTERS WITH 3-STATE OUTPUTS

SCBS706F – AUGUST 1997 – REVISED OCTOBER 2003

- Support Mixed-Mode Signal Operation (5-V Input and Output Voltages With 3.3-V  $V_{CC}$ )
- Support Unregulated Battery Operation Down to 2.7 V
- Typical  $V_{OLP}$  (Output Ground Bounce) <0.8 V at  $V_{CC} = 3.3$  V,  $T_A = 25^\circ\text{C}$
- $I_{off}$  and Power-Up 3-State Support Hot Insertion
- Bus Hold on Data Inputs Eliminates the Need for External Pullup/Pulldown Resistors
- Latch-Up Performance Exceeds 500 mA Per JESD 17
- ESD Protection Exceeds JESD 22
  - 2000-V Human-Body Model (A114-A)
  - 200-V Machine Model (A115-A)

SN54LVTH652 . . . JT OR W PACKAGE  
SN74LVTH652 . . . DB, DGV, DW, NS, OR PW PACKAGE  
(TOP VIEW)

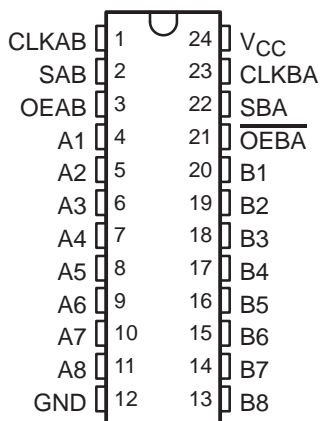

SN54LVTH652 . . . FK PACKAGE  
(TOP VIEW)

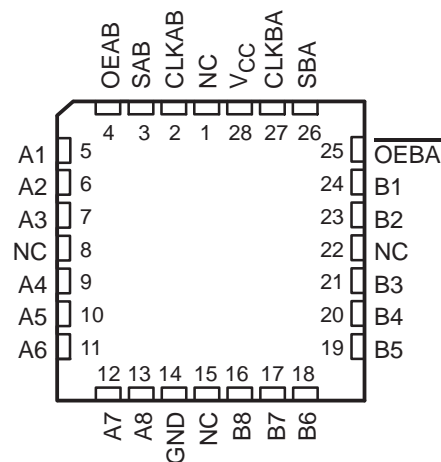

NC – No internal connection

## description/ordering information

These bus transceivers and registers are designed specifically for low-voltage (3.3-V)  $V_{CC}$  operation, but with the capability to provide a TTL interface to a 5-V system environment.

## ORDERING INFORMATION

$T_A$	PACKAGE†		ORDERABLE PART NUMBER	TOP-SIDE MARKING
-40°C to 85°C	SOIC – DW	Tube	SN74LVTH652DW	LVTH652
		Tape and reel	SN74LVTH652DWR	
	SOP – NS	Tape and reel	SN74LVTH652NSR	LVTH652
	SSOP – DB	Tape and reel	SN74LVTH652DBR	LXH652
	TSSOP – PW	Tube	SN74LVTH652PW	LXH652
		Tape and reel	SN74LVTH652PWR	
	TVSOP – DGV	Tape and reel	SN74LVTH652DGVR	LXH652
-55°C to 125°C	CDIP – JT	Tube	SNJ54LVTH652JT	SNJ54LVTH652JT
	CFP – W	Tube	SNJ54LVTH652W	SNJ54LVTH652W
	LCCC – FK	Tube	SNJ54LVTH652FK	SNJ54LVTH652FK

† Package drawings, standard packing quantities, thermal data, symbolization, and PCB design guidelines are available at [www.ti.com/sc/package](http://www.ti.com/sc/package).



Please be aware that an important notice concerning availability, standard warranty, and use in critical applications of Texas Instruments semiconductor products and disclaimers thereto appears at the end of this data sheet.

UNLESS OTHERWISE NOTED this document contains PRODUCTION DATA information current as of publication date. Products conform to specifications per the terms of Texas Instruments standard warranty. Production processing does not necessarily include testing of all parameters.

**TEXAS  
INSTRUMENTS**

POST OFFICE BOX 655303 • DALLAS, TEXAS 75265

Copyright © 2003, Texas Instruments Incorporated

# SN54LVTH652, SN74LVTH652

## 3.3-V ABT OCTAL BUS TRANSCEIVERS AND REGISTERS WITH 3-STATE OUTPUTS

SCBS706F – AUGUST 1997 – REVISED OCTOBER 2003

### description/ordering information (continued)

The 'LVTH652 devices consist of bus-transceiver circuits, D-type flip-flops, and control circuitry arranged for multiplexed transmission of data directly from the data bus or from the internal storage registers.

Output-enable (OEAB and  $\overline{\text{OEBA}}$ ) inputs are provided to control the transceiver functions. Select-control (SAB and SBA) inputs are provided to select whether real-time or stored data is transferred. The circuitry used for select control eliminates the typical decoding glitch that occurs in a multiplexer during the transition between real-time and stored data. A low input selects real-time data and a high input selects stored data. Figure 1 illustrates the four fundamental bus-management functions that can be performed with the 'LVTH652 devices.

Data on the A or B data bus, or both, can be stored in the internal D-type flip-flops by low-to-high transitions at the appropriate clock (CLKAB or CLKBA) inputs, regardless of the select- or enable-control pins. When SAB and SBA are in the real-time transfer mode, it is possible to store data without using the internal D-type flip-flops by simultaneously enabling OEAB and  $\overline{\text{OEBA}}$ . In this configuration, each output reinforces its input; therefore, when all other data sources to the two sets of bus lines are at high impedance, each set of bus lines remains at its last state.

Active bus-hold circuitry is provided to hold unused or floating data inputs at a valid logic level. Use of pullup or pulldown resistors with the bus-hold circuitry is not recommended.

When  $V_{CC}$  is between 0 and 1.5 V, the device is in the high-impedance state during power up or power down. However, to ensure the high-impedance state above 1.5 V,  $\overline{\text{OE}}$  should be tied to  $V_{CC}$  through a pullup resistor and OE should be tied to GND through a pulldown resistor; the minimum value of the resistor is determined by the current-sinking/current-sourcing capability of the driver.

This device is fully specified for hot-insertion applications using  $I_{off}$  and power-up 3-state. The  $I_{off}$  circuitry disables the outputs, preventing damaging current backflow through the device when it is powered down. The power-up 3-state circuitry places the outputs in the high-impedance state during power up and power down, which prevents driver conflict.

FUNCTION TABLE

INPUTS						DATA I/O†		OPERATION OR FUNCTION
OEAB	$\overline{\text{OEBA}}$	CLKAB	CLKBA	SAB	SBA	A1–A8	B1–B8	
L	H	H or L	H or L	X	X	Input	Input	Isolation
L	H	↑	↑	X	X	Input	Input	Store A and B data
X	H	↑	H or L	X	X	Input	Unspecified‡	Store A, hold B
H	H	↑	↑	X‡	X	Input	Output	Store A in both registers
L	X	H or L	↑	X	X	Unspecified‡	Input	Hold A, store B
L	L	↑	↑	X	X‡	Output	Input	Store B in both registers
L	L	X	X	X	L	Output	Input	Real-time B data to A bus
L	L	X	H or L	X	H	Output	Input	Stored B data to A bus
H	H	X	X	L	X	Input	Output	Real-time A data to B bus
H	H	H or L	X	H	X	Input	Output	Stored A data to B bus
H	L	H or L	H or L	H	H	Output	Output	Stored A data to B bus and stored B data to A bus

† The data-output functions can be enabled or disabled by a variety of level combinations at OEAB or  $\overline{\text{OEBA}}$ . Data-input functions always are enabled; i.e., data at the bus terminals is stored on every low-to-high transition of the clock inputs.

‡ Select control = L; clocks can occur simultaneously.

Select control = H; clocks must be staggered to load both registers.



# SN54LVTH652, SN74LVTH652 3.3-V ABT OCTAL BUS TRANSCEIVERS AND REGISTERS WITH 3-STATE OUTPUTS

SCBS706F – AUGUST 1997 – REVISED OCTOBER 2003

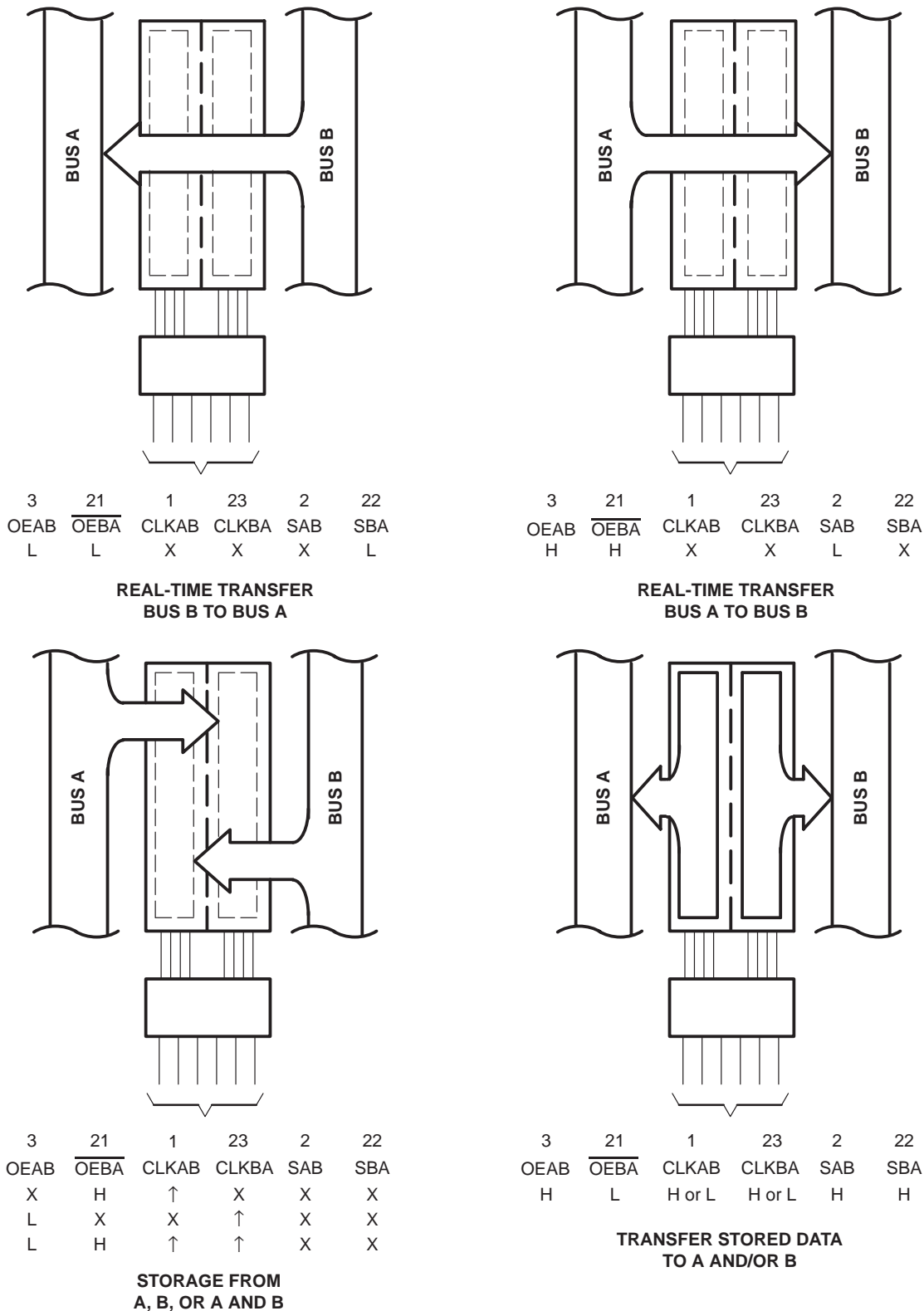

Pin numbers shown are for the DB, DGV, DW, JT, NS, PW, and W packages.

**Figure 1. Bus-Management Functions**

# SN54LVTH652, SN74LVTH652

## 3.3-V ABT OCTAL BUS TRANSCEIVERS AND REGISTERS

### WITH 3-STATE OUTPUTS

SCBS706F – AUGUST 1997 – REVISED OCTOBER 2003

#### logic diagram (positive logic)

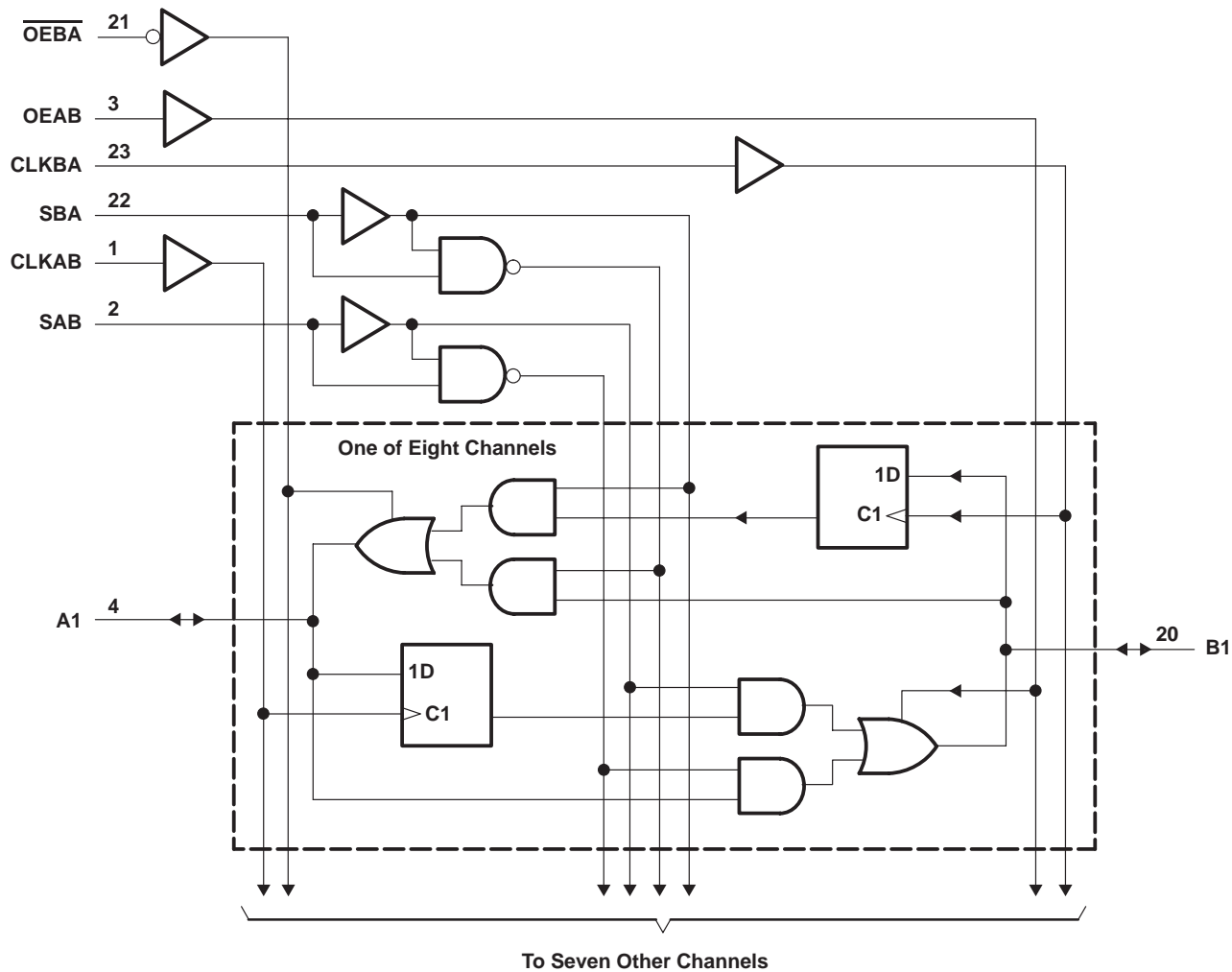

Pin numbers shown are for the DB, DGV, DW, JT, NS, PW, and W packages.

# SN54LVTH652, SN74LVTH652 3.3-V ABT OCTAL BUS TRANSCEIVERS AND REGISTERS WITH 3-STATE OUTPUTS

SCBS706F – AUGUST 1997 – REVISED OCTOBER 2003

## absolute maximum ratings over operating free-air temperature range (unless otherwise noted)†

Supply voltage range, $V_{CC}$ .....	–0.5 V to 4.6 V
Input voltage range, $V_I$ (see Note 1) .....	–0.5 V to 7 V
Voltage range applied to any output in the high-impedance or power-off state, $V_O$ (see Note 1) .....	–0.5 V to 7 V
Voltage range applied to any output in the high state, $V_O$ (see Note 1) .....	–0.5 V to $V_{CC} + 0.5$ V
Current into any output in the low state, $I_O$ : SN54LVTH652 .....	96 mA
SN74LVTH652) .....	128 mA
Current into any output in the high state, $I_O$ (see Note 2): SN54LVTH652 .....	8 mA
SN74LVTH652 .....	64 mA
Input clamp current, $I_{IK}$ ( $V_I < 0$ ) .....	–50 mA
Output clamp current, $I_{OK}$ ( $V_O < 0$ ) .....	–50 mA
Package thermal impedance, $\theta_{JA}$ (see Note 3): DB package .....	63°C/W
DGV package .....	86°C/W
DW package .....	46°C/W
NS package .....	65°C/W
PW package .....	88°C/W
Storage temperature range, $T_{stg}$ .....	–65°C to 150°C

† Stresses beyond those listed under “absolute maximum ratings” may cause permanent damage to the device. These are stress ratings only, and functional operation of the device at these or any other conditions beyond those indicated under “recommended operating conditions” is not implied. Exposure to absolute-maximum-rated conditions for extended periods may affect device reliability.

- NOTES: 1. The input and output negative-voltage ratings may be exceeded if the input and output clamp-current ratings are observed.  
 2. This current flows only when the output is in the high state and  $V_O > V_{CC}$ .  
 3. The package thermal impedance is calculated in accordance with JESD 51-7.

## recommended operating conditions (see Note 4)

		SN54LVTH652		SN74LVTH652		UNIT
		MIN	MAX	MIN	MAX	
$V_{CC}$	Supply voltage	2.7	3.6	2.7	3.6	V
$V_{IH}$	High-level input voltage	2		2		V
$V_{IL}$	Low-level input voltage		0.8		0.8	V
$V_I$	Input voltage		5.5		5.5	V
$I_{OH}$	High-level output current		–24		–32	mA
$I_{OL}$	Low-level output current		48		64	mA
$\Delta t/\Delta v$	Input transition rise or fall rate	Outputs enabled		10	10	ns/V
$\Delta t/\Delta V_{CC}$	Power-up ramp rate	200		200		µs/V
$T_A$	Operating free-air temperature	–55	125	–40	85	°C

NOTE 4: All unused control inputs of the device must be held at  $V_{CC}$  or GND to ensure proper device operation. Refer to the TI application report, *Implications of Slow or Floating CMOS Inputs*, literature number SCBA004.

# SN54LVTH652, SN74LVTH652

## 3.3-V ABT OCTAL BUS TRANSCEIVERS AND REGISTERS WITH 3-STATE OUTPUTS

SCBS706F – AUGUST 1997 – REVISED OCTOBER 2003

electrical characteristics over recommended operating free-air temperature range (unless otherwise noted)

PARAMETER	TEST CONDITIONS		SN54LVTH652			SN74LVTH652			UNIT	
			MIN	TYP†	MAX	MIN	TYP†	MAX		
$V_{IK}$	$V_{CC} = 2.7\text{ V}$ , $I_I = -18\text{ mA}$		-1.2			-1.2			V	
$V_{OH}$	$V_{CC} = 2.7\text{ V to }3.6\text{ V}$ , $I_{OH} = -100\text{ }\mu\text{A}$		$V_{CC}-0.2$			$V_{CC}-0.2$			V	
	$V_{CC} = 2.7\text{ V}$ , $I_{OH} = -8\text{ mA}$		2.4			2.4				
	$V_{CC} = 3\text{ V}$		2			2				
$V_{OL}$	$V_{CC} = 2.7\text{ V}$		$I_{OL} = 100\text{ }\mu\text{A}$		0.2			0.2		
			$I_{OL} = 24\text{ mA}$		0.5			0.5		
	$V_{CC} = 3\text{ V}$		$I_{OL} = 16\text{ mA}$		0.4			0.4		
			$I_{OL} = 32\text{ mA}$		0.5			0.5		
			$I_{OL} = 48\text{ mA}$		0.55			0.55		
$I_{OL} = 64\text{ mA}$					0.55					
$I_I$	Control inputs	$V_{CC} = 3.6\text{ V}$ , $V_I = V_{CC}\text{ or GND}$		$\pm 1$			$\pm 1$			
		$V_{CC} = 0\text{ or }3.6\text{ V}$ , $V_I = 5.5\text{ V}$		10			10			
	A or B ports‡	$V_{CC} = 3.6\text{ V}$		$V_I = 5.5\text{ V}$		20			20	
				$V_I = 0$		-5			-5	
$I_{off}$	$V_{CC} = 0$ , $V_I\text{ or }V_O = 0\text{ to }4.5\text{ V}$					$\pm 100$			$\mu\text{A}$	
$I_{I(\text{hold})}$	A or B ports	$V_{CC} = 3\text{ V}$		$V_I = 0.8\text{ V}$		75			75	
		$V_{CC} = 3.6\text{ V}\text{§}$		$V_I = 2\text{ V}$		-75			-75	
		$V_{CC} = 3.6\text{ V}\text{§}$		$V_I = 0\text{ to }3.6\text{ V}$					$\pm 500$	
$I_{OZPU}$	$V_{CC} = 0\text{ to }1.5\text{ V}$ , $V_O = 0.5\text{ to }3\text{ V}$ , $OE/OE = \text{don't care}$		$\pm 100^*$			$\pm 100$			$\mu\text{A}$	
$I_{OZPD}$	$V_{CC} = 1.5\text{ V to }0$ , $V_O = 0.5\text{ to }3\text{ V}$ , $OE/OE = \text{don't care}$		$\pm 100^*$			$\pm 100$			$\mu\text{A}$	
$I_{CC}$	$V_{CC} = 3.6\text{ V}$ , $I_O = 0$ , $V_I = V_{CC}\text{ or GND}$		Outputs high		0.19			0.19		
			Outputs low		5			5		
			Outputs disabled		0.19			0.19		
$\Delta I_{CC}\text{¶}$	$V_{CC} = 3\text{ V to }3.6\text{ V}$ , One input at $V_{CC} - 0.6\text{ V}$ , Other inputs at $V_{CC}\text{ or GND}$		0.2			0.2			mA	
$C_i$	$V_I = 3\text{ V or }0$		4			4			pF	
$C_{io}$	$V_O = 3\text{ V or }0$		9			9			pF	

\* On products compliant to MIL-PRF-38535, this parameter is not production tested.

† All typical values are at  $V_{CC} = 3.3\text{ V}$ ,  $T_A = 25^\circ\text{C}$ .

‡ Unused terminals at  $V_{CC}$  or GND

§ This is the bus-hold maximum dynamic current. It is the minimum overdrive current required to switch the input from one state to another.

¶ This is the increase in supply current for each input that is at the specified TTL voltage level, rather than  $V_{CC}$  or GND.

PRODUCT PREVIEW information concerns products in the formative or design phase of development. Characteristic data and other specifications are design goals. Texas Instruments reserves the right to change or discontinue these products without notice.



POST OFFICE BOX 655303 • DALLAS, TEXAS 75265

# SN54LVTH652, SN74LVTH652 3.3-V ABT OCTAL BUS TRANSCEIVERS AND REGISTERS WITH 3-STATE OUTPUTS

SCBS706F – AUGUST 1997 – REVISED OCTOBER 2003

timing requirements over recommended operating free-air temperature range (unless otherwise noted) (see Figure 2)

		SN54LVTH652				SN74LVTH652				UNIT
		V <sub>CC</sub> = 3.3 V ± 0.3 V		V <sub>CC</sub> = 2.7 V		V <sub>CC</sub> = 3.3 V ± 0.3 V		V <sub>CC</sub> = 2.7 V		
		MIN	MAX	MIN	MAX	MIN	MAX	MIN	MAX	
f <sub>clock</sub>	Clock frequency	150		150		150		150		MHz
t <sub>w</sub>	Pulse duration, CLK high or low	3.3		3.3		3.3		3.3		ns
t <sub>su</sub>	Setup time, A or B before CLKAB↑ or CLKBA↑	Data high	1.3	1.6	1.2	1.5			ns	
		Data low	1.9	2.6	1.6	2.2				
t <sub>h</sub>	Hold time, A or B after CLKAB↑ or CLKBA↑	1.2		1.2		0.8		0.8		ns

switching characteristics over recommended operating free-air temperature range, C<sub>L</sub> = 50 pF (unless otherwise noted) (see Figure 2)

PARAMETER	FROM (INPUT)	TO (OUTPUT)	SN54LVTH652				SN74LVTH652				UNIT	
			V <sub>CC</sub> = 3.3 V ± 0.3 V		V <sub>CC</sub> = 2.7 V		V <sub>CC</sub> = 3.3 V ± 0.3 V			V <sub>CC</sub> = 2.7 V		
			MIN	MAX	MIN	MAX	MIN	TYP†	MAX	MIN		MAX
f <sub>max</sub>			150		150		150			150		MHz
t <sub>PLH</sub>	CLKBA or CLKAB	A or B	1.7	5	5.9		1.8	3.1	4.7	5.6		ns
t <sub>PHL</sub>			1.7	5	5.9		1.8	3.1	4.7	5.6		
t <sub>PLH</sub>	A or B	B or A	1.2	3.7	4.3		1.3	2.3	3.5	4.1		ns
t <sub>PHL</sub>			1.2	3.7	4.3		1.3	2.4	3.5	4.1		
t <sub>PLH</sub>	SBA or SAB‡	A or B	1.4	5.2	6.3		1.5	3.1	4.9	6		ns
t <sub>PHL</sub>			1.4	5.2	6.3		1.5	3.4	4.9	6		
t <sub>PZH</sub>	$\overline{\text{OEBA}}$	A	1	5.4	6.7		1.1	2.9	5.2	6.5		ns
t <sub>PZL</sub>			1	5.4	6.7		1.1	3.1	5.2	6.5		
t <sub>PHZ</sub>	$\overline{\text{OEBA}}$	A	2.2	5.9	6.5		2.3	3.5	5.5	6.1		ns
t <sub>PLZ</sub>			2.2	5.9	6.3		2.3	3.7	5.5	5.9		
t <sub>PZH</sub>	OEAB	B	1.2	4.9	5.9		1.3	3	4.7	5.7		ns
t <sub>PZL</sub>			1.2	4.9	5.9		1.3	3.3	4.7	5.7		
t <sub>PHZ</sub>	OEAB	B	1.4	5.8	7		1.5	3.6	5.6	6.7		ns
t <sub>PLZ</sub>			1.4	5.9	6.6		1.5	3.7	5.6	6.3		

† All typical values are at V<sub>CC</sub> = 3.3 V, T<sub>A</sub> = 25°C.

‡ These parameters are measured with the internal output state of the storage register opposite that of the bus input.

# SN54LVTH652, SN74LVTH652

## 3.3-V ABT OCTAL BUS TRANSCEIVERS AND REGISTERS WITH 3-STATE OUTPUTS

SCBS706F – AUGUST 1997 – REVISED OCTOBER 2003

### PARAMETER MEASUREMENT INFORMATION

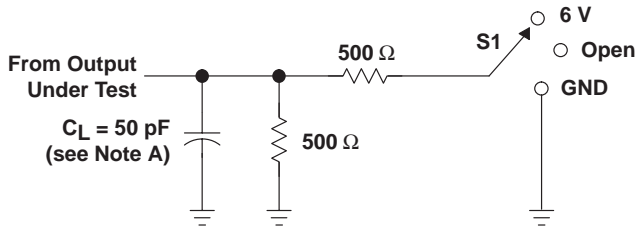

LOAD CIRCUIT

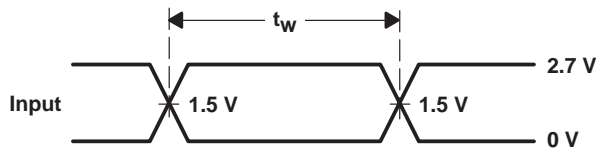

VOLTAGE WAVEFORMS  
PULSE DURATION

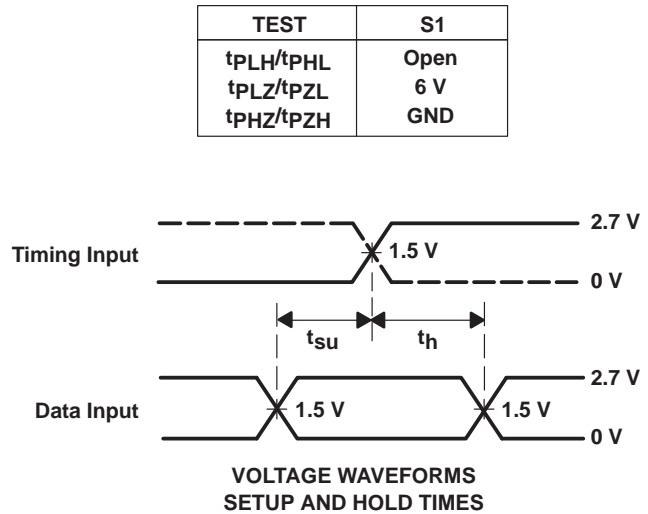

VOLTAGE WAVEFORMS  
SETUP AND HOLD TIMES

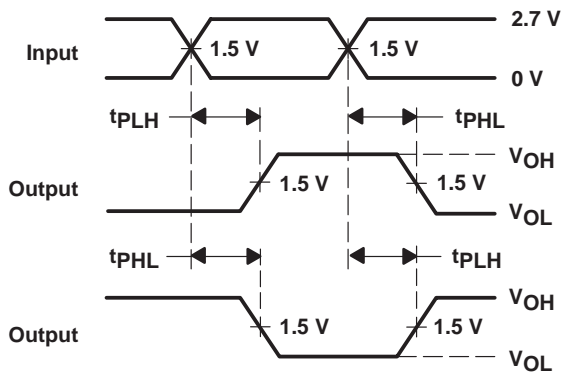

VOLTAGE WAVEFORMS  
PROPAGATION DELAY TIMES  
INVERTING AND NONINVERTING OUTPUTS

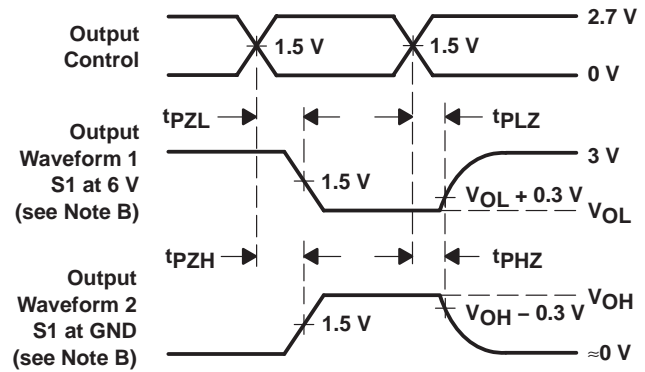

VOLTAGE WAVEFORMS  
ENABLE AND DISABLE TIMES  
LOW- AND HIGH-LEVEL ENABLING

- NOTES: A.  $C_L$  includes probe and jig capacitance.  
 B. Waveform 1 is for an output with internal conditions such that the output is low except when disabled by the output control. Waveform 2 is for an output with internal conditions such that the output is high except when disabled by the output control.  
 C. All input pulses are supplied by generators having the following characteristics:  $PRR \leq 10$  MHz,  $Z_O = 50 \Omega$ ,  $t_r \leq 2.5$  ns,  $t_f \leq 2.5$  ns.  
 D. The outputs are measured one at a time with one transition per measurement.  
 E. All parameters and waveforms are not applicable to all devices.

Figure 2. Load Circuit and Voltage Waveforms

**PACKAGING INFORMATION**

Orderable Device	Status <sup>(1)</sup>	Package Type	Package Drawing	Pins	Package Qty	Eco Plan <sup>(2)</sup>	Lead/ Ball Finish	MSL Peak Temp <sup>(3)</sup>	Samples (Requires Login)
SN74LVTH652DBLE	OBSOLETE	SSOP	DB	24		TBD	Call TI	Call TI	
SN74LVTH652DBR	ACTIVE	SSOP	DB	24	2000	Green (RoHS & no Sb/Br)	CU NIPDAU	Level-1-260C-UNLIM	
SN74LVTH652DBRE4	ACTIVE	SSOP	DB	24	2000	Green (RoHS & no Sb/Br)	CU NIPDAU	Level-1-260C-UNLIM	
SN74LVTH652DBRG4	ACTIVE	SSOP	DB	24	2000	Green (RoHS & no Sb/Br)	CU NIPDAU	Level-1-260C-UNLIM	
SN74LVTH652DGVR	ACTIVE	TVSOP	DGV	24	2000	Green (RoHS & no Sb/Br)	CU NIPDAU	Level-1-260C-UNLIM	
SN74LVTH652DGVRE4	ACTIVE	TVSOP	DGV	24	2000	Green (RoHS & no Sb/Br)	CU NIPDAU	Level-1-260C-UNLIM	
SN74LVTH652DGVRG4	ACTIVE	TVSOP	DGV	24	2000	Green (RoHS & no Sb/Br)	CU NIPDAU	Level-1-260C-UNLIM	
SN74LVTH652DW	ACTIVE	SOIC	DW	24	25	Green (RoHS & no Sb/Br)	CU NIPDAU	Level-1-260C-UNLIM	
SN74LVTH652DWE4	ACTIVE	SOIC	DW	24	25	Green (RoHS & no Sb/Br)	CU NIPDAU	Level-1-260C-UNLIM	
SN74LVTH652DWG4	ACTIVE	SOIC	DW	24	25	Green (RoHS & no Sb/Br)	CU NIPDAU	Level-1-260C-UNLIM	
SN74LVTH652PW	ACTIVE	TSSOP	PW	24	60	Green (RoHS & no Sb/Br)	CU NIPDAU	Level-1-260C-UNLIM	
SN74LVTH652PWE4	ACTIVE	TSSOP	PW	24	60	Green (RoHS & no Sb/Br)	CU NIPDAU	Level-1-260C-UNLIM	
SN74LVTH652PWG4	ACTIVE	TSSOP	PW	24	60	Green (RoHS & no Sb/Br)	CU NIPDAU	Level-1-260C-UNLIM	
SN74LVTH652PWLE	OBSOLETE	TSSOP	PW	24		TBD	Call TI	Call TI	
SN74LVTH652PWR	ACTIVE	TSSOP	PW	24	2000	Green (RoHS & no Sb/Br)	CU NIPDAU	Level-1-260C-UNLIM	
SN74LVTH652PWRE4	ACTIVE	TSSOP	PW	24	2000	Green (RoHS & no Sb/Br)	CU NIPDAU	Level-1-260C-UNLIM	
SN74LVTH652PWRG4	ACTIVE	TSSOP	PW	24	2000	Green (RoHS & no Sb/Br)	CU NIPDAU	Level-1-260C-UNLIM	

<sup>(1)</sup> The marketing status values are defined as follows:

---

**ACTIVE:** Product device recommended for new designs.

**LIFEBUY:** TI has announced that the device will be discontinued, and a lifetime-buy period is in effect.

**NRND:** Not recommended for new designs. Device is in production to support existing customers, but TI does not recommend using this part in a new design.

**PREVIEW:** Device has been announced but is not in production. Samples may or may not be available.

**OBSOLETE:** TI has discontinued the production of the device.

<sup>(2)</sup> Eco Plan - The planned eco-friendly classification: Pb-Free (RoHS), Pb-Free (RoHS Exempt), or Green (RoHS & no Sb/Br) - please check <http://www.ti.com/productcontent> for the latest availability information and additional product content details.

**TBD:** The Pb-Free/Green conversion plan has not been defined.

**Pb-Free (RoHS):** TI's terms "Lead-Free" or "Pb-Free" mean semiconductor products that are compatible with the current RoHS requirements for all 6 substances, including the requirement that lead not exceed 0.1% by weight in homogeneous materials. Where designed to be soldered at high temperatures, TI Pb-Free products are suitable for use in specified lead-free processes.

**Pb-Free (RoHS Exempt):** This component has a RoHS exemption for either 1) lead-based flip-chip solder bumps used between the die and package, or 2) lead-based die adhesive used between the die and leadframe. The component is otherwise considered Pb-Free (RoHS compatible) as defined above.

**Green (RoHS & no Sb/Br):** TI defines "Green" to mean Pb-Free (RoHS compatible), and free of Bromine (Br) and Antimony (Sb) based flame retardants (Br or Sb do not exceed 0.1% by weight in homogeneous material)

<sup>(3)</sup> MSL, Peak Temp. -- The Moisture Sensitivity Level rating according to the JEDEC industry standard classifications, and peak solder temperature.

**Important Information and Disclaimer:** The information provided on this page represents TI's knowledge and belief as of the date that it is provided. TI bases its knowledge and belief on information provided by third parties, and makes no representation or warranty as to the accuracy of such information. Efforts are underway to better integrate information from third parties. TI has taken and continues to take reasonable steps to provide representative and accurate information but may not have conducted destructive testing or chemical analysis on incoming materials and chemicals. TI and TI suppliers consider certain information to be proprietary, and thus CAS numbers and other limited information may not be available for release.

In no event shall TI's liability arising out of such information exceed the total purchase price of the TI part(s) at issue in this document sold by TI to Customer on an annual basis.

**OTHER QUALIFIED VERSIONS OF SN74LVTH652 :**

- Enhanced Product: [SN74LVTH652-EP](#)

NOTE: Qualified Version Definitions:

- Enhanced Product - Supports Defense, Aerospace and Medical Applications

**TAPE AND REEL INFORMATION**
**REEL DIMENSIONS**

**TAPE DIMENSIONS**

A0	Dimension designed to accommodate the component width
B0	Dimension designed to accommodate the component length
K0	Dimension designed to accommodate the component thickness
W	Overall width of the carrier tape
P1	Pitch between successive cavity centers

**TAPE AND REEL INFORMATION**

\*All dimensions are nominal

Device	Package Type	Package Drawing	Pins	SPQ	Reel Diameter (mm)	Reel Width W1 (mm)	A0 (mm)	B0 (mm)	K0 (mm)	P1 (mm)	W (mm)	Pin1 Quadrant
SN74LVTH652DBR	SSOP	DB	24	2000	330.0	16.4	8.2	8.8	2.5	12.0	16.0	Q1
SN74LVTH652DGV	TVSOP	DGV	24	2000	330.0	12.4	6.9	5.6	1.6	8.0	12.0	Q1
SN74LVTH652PWR	TSSOP	PW	24	2000	330.0	16.4	6.95	8.3	1.6	8.0	16.0	Q1

**TAPE AND REEL BOX DIMENSIONS**

\*All dimensions are nominal

Device	Package Type	Package Drawing	Pins	SPQ	Length (mm)	Width (mm)	Height (mm)
SN74LVTH652DBR	SSOP	DB	24	2000	367.0	367.0	38.0
SN74LVTH652DGVR	TVSOP	DGV	24	2000	367.0	367.0	35.0
SN74LVTH652PWR	TSSOP	PW	24	2000	367.0	367.0	38.0

DGV (R-PDSO-G\*\*)

PLASTIC SMALL-OUTLINE

24 PINS SHOWN



- NOTES: A. All linear dimensions are in millimeters.  
 B. This drawing is subject to change without notice.  
 C. Body dimensions do not include mold flash or protrusion, not to exceed 0,15 per side.  
 D. Falls within JEDEC: 24/48 Pins – MO-153  
 14/16/20/56 Pins – MO-194

DW (R-PDSO-G24)

PLASTIC SMALL OUTLINE



- NOTES:
- A. All linear dimensions are in inches (millimeters). Dimensioning and tolerancing per ASME Y14.5M-1994.
  - B. This drawing is subject to change without notice.
  - C. Body dimensions do not include mold flash or protrusion not to exceed 0.006 (0,15).
  - D. Falls within JEDEC MS-013 variation AD.

DW (R-PDSO-G24)

PLASTIC SMALL OUTLINE

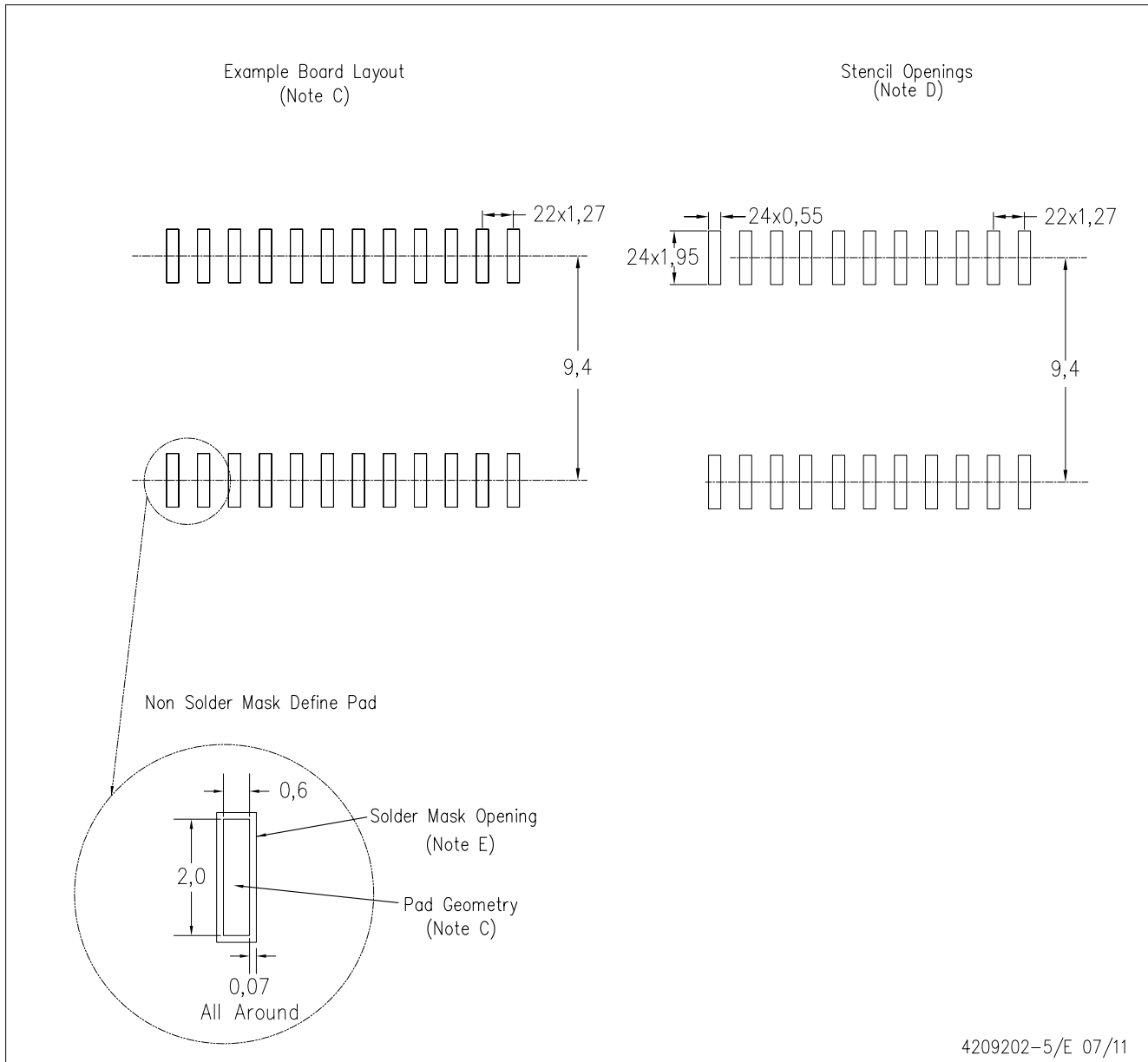

4209202-5/E 07/11

- NOTES:
- A. All linear dimensions are in millimeters.
  - B. This drawing is subject to change without notice.
  - C. Refer to IPC7351 for alternate board design.
  - D. Laser cutting apertures with trapezoidal walls and also rounding corners will offer better paste release. Customers should contact their board assembly site for stencil design recommendations. Refer to IPC-7525
  - E. Customers should contact their board fabrication site for solder mask tolerances between and around signal pads.

PW (R-PDSO-G24)

PLASTIC SMALL OUTLINE

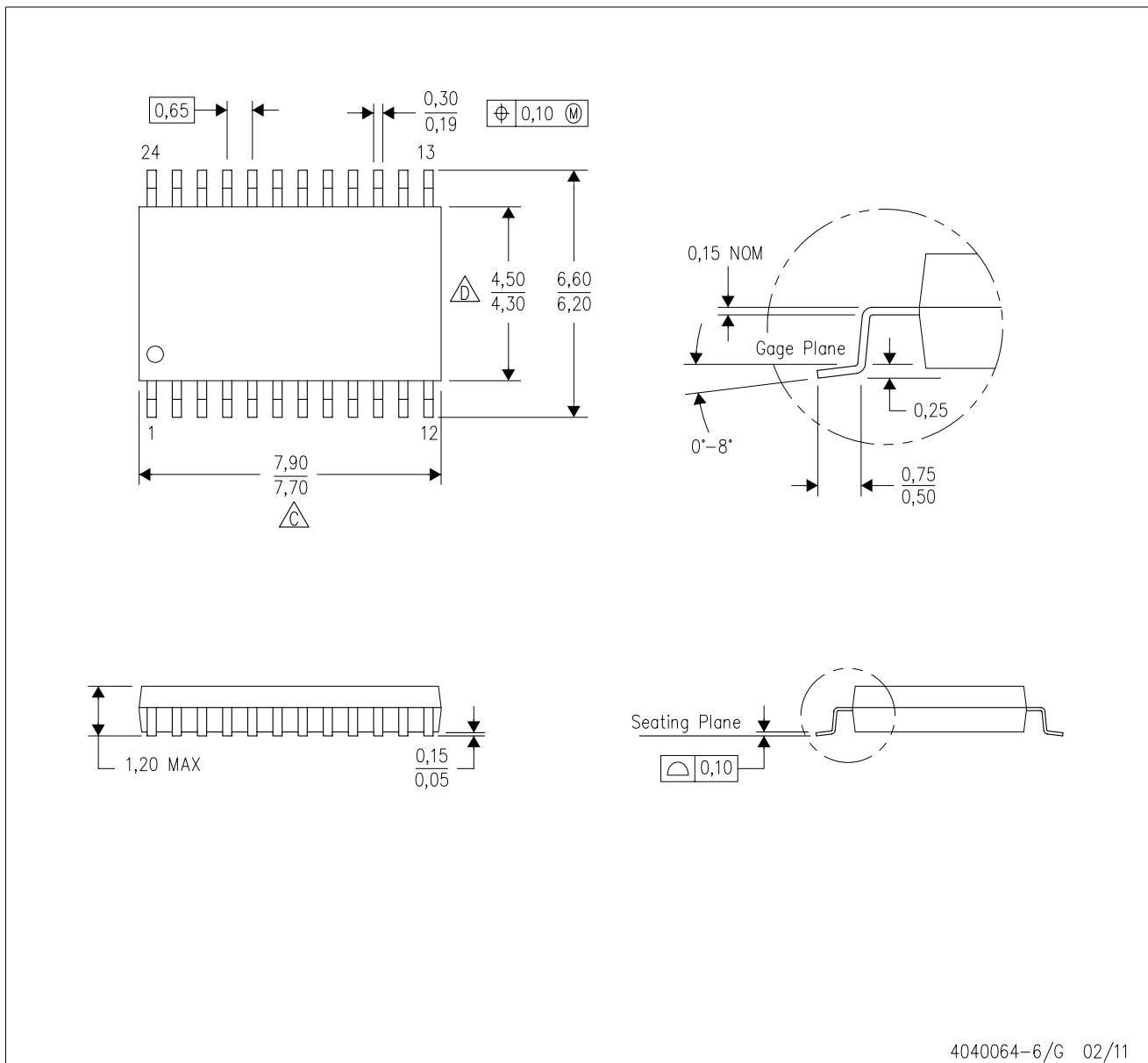

- NOTES:
- A. All linear dimensions are in millimeters. Dimensioning and tolerancing per ASME Y14.5M-1994.
  - B. This drawing is subject to change without notice.
  - C. Body length does not include mold flash, protrusions, or gate burrs. Mold flash, protrusions, or gate burrs shall not exceed 0,15 each side.
  - D. Body width does not include interlead flash. Interlead flash shall not exceed 0,25 each side.
  - E. Falls within JEDEC MO-153

PW (R-PDSO-G24)

PLASTIC SMALL OUTLINE

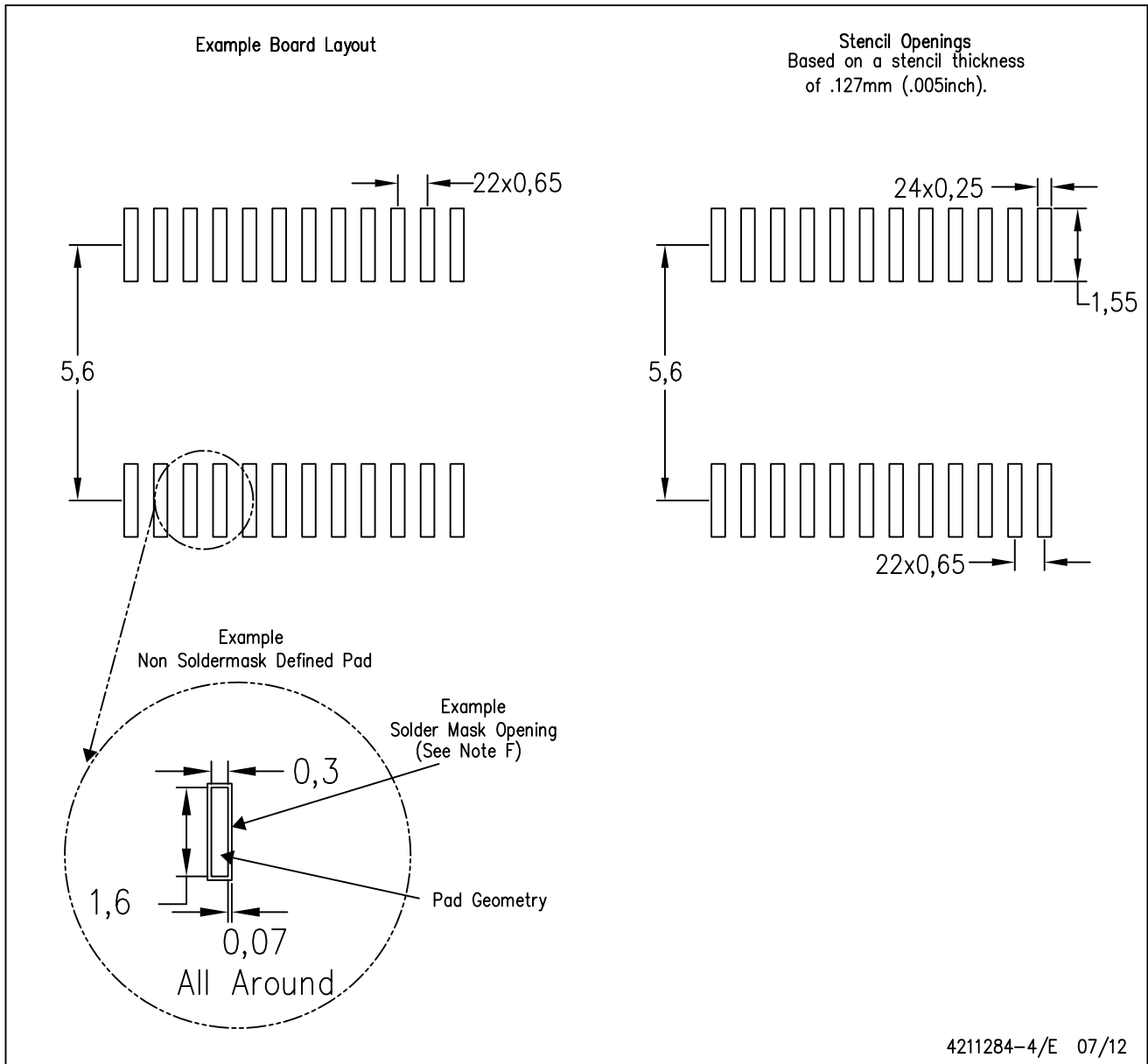

- NOTES:
- A. All linear dimensions are in millimeters.
  - B. This drawing is subject to change without notice.
  - C. Publication IPC-7351 is recommended for alternate design.
  - D. Laser cutting apertures with trapezoidal walls and also rounding corners will offer better paste release. Customers should contact their board assembly site for stencil design recommendations. Refer to IPC-7525 for other stencil recommendations.
  - E. Customers should contact their board fabrication site for solder mask tolerances between and around signal pads.

DB (R-PDSO-G\*\*)

PLASTIC SMALL-OUTLINE

28 PINS SHOWN



- NOTES: A. All linear dimensions are in millimeters.  
 B. This drawing is subject to change without notice.  
 C. Body dimensions do not include mold flash or protrusion not to exceed 0,15.  
 D. Falls within JEDEC MO-150

## IMPORTANT NOTICE

Texas Instruments Incorporated and its subsidiaries (TI) reserve the right to make corrections, enhancements, improvements and other changes to its semiconductor products and services per JESD46C and to discontinue any product or service per JESD48B. Buyers should obtain the latest relevant information before placing orders and should verify that such information is current and complete. All semiconductor products (also referred to herein as "components") are sold subject to TI's terms and conditions of sale supplied at the time of order acknowledgment.

TI warrants performance of its components to the specifications applicable at the time of sale, in accordance with the warranty in TI's terms and conditions of sale of semiconductor products. Testing and other quality control techniques are used to the extent TI deems necessary to support this warranty. Except where mandated by applicable law, testing of all parameters of each component is not necessarily performed.

TI assumes no liability for applications assistance or the design of Buyers' products. Buyers are responsible for their products and applications using TI components. To minimize the risks associated with Buyers' products and applications, Buyers should provide adequate design and operating safeguards.

TI does not warrant or represent that any license, either express or implied, is granted under any patent right, copyright, mask work right, or other intellectual property right relating to any combination, machine, or process in which TI components or services are used. Information published by TI regarding third-party products or services does not constitute a license to use such products or services or a warranty or endorsement thereof. Use of such information may require a license from a third party under the patents or other intellectual property of the third party, or a license from TI under the patents or other intellectual property of TI.

Reproduction of significant portions of TI information in TI data books or data sheets is permissible only if reproduction is without alteration and is accompanied by all associated warranties, conditions, limitations, and notices. TI is not responsible or liable for such altered documentation. Information of third parties may be subject to additional restrictions.

Resale of TI components or services with statements different from or beyond the parameters stated by TI for that component or service voids all express and any implied warranties for the associated TI component or service and is an unfair and deceptive business practice. TI is not responsible or liable for any such statements.

Buyer acknowledges and agrees that it is solely responsible for compliance with all legal, regulatory and safety-related requirements concerning its products, and any use of TI components in its applications, notwithstanding any applications-related information or support that may be provided by TI. Buyer represents and agrees that it has all the necessary expertise to create and implement safeguards which anticipate dangerous consequences of failures, monitor failures and their consequences, lessen the likelihood of failures that might cause harm and take appropriate remedial actions. Buyer will fully indemnify TI and its representatives against any damages arising out of the use of any TI components in safety-critical applications.

In some cases, TI components may be promoted specifically to facilitate safety-related applications. With such components, TI's goal is to help enable customers to design and create their own end-product solutions that meet applicable functional safety standards and requirements. Nonetheless, such components are subject to these terms.

No TI components are authorized for use in FDA Class III (or similar life-critical medical equipment) unless authorized officers of the parties have executed a special agreement specifically governing such use.

Only those TI components which TI has specifically designated as military grade or "enhanced plastic" are designed and intended for use in military/aerospace applications or environments. Buyer acknowledges and agrees that any military or aerospace use of TI components which have **not** been so designated is solely at the Buyer's risk, and that Buyer is solely responsible for compliance with all legal and regulatory requirements in connection with such use.

TI has specifically designated certain components which meet ISO/TS16949 requirements, mainly for automotive use. Components which have not been so designated are neither designed nor intended for automotive use; and TI will not be responsible for any failure of such components to meet such requirements.

### Products

Audio	<a href="http://www.ti.com/audio">www.ti.com/audio</a>
Amplifiers	<a href="http://amplifier.ti.com">amplifier.ti.com</a>
Data Converters	<a href="http://dataconverter.ti.com">dataconverter.ti.com</a>
DLP® Products	<a href="http://www.dlp.com">www.dlp.com</a>
DSP	<a href="http://dsp.ti.com">dsp.ti.com</a>
Clocks and Timers	<a href="http://www.ti.com/clocks">www.ti.com/clocks</a>
Interface	<a href="http://interface.ti.com">interface.ti.com</a>
Logic	<a href="http://logic.ti.com">logic.ti.com</a>
Power Mgmt	<a href="http://power.ti.com">power.ti.com</a>
Microcontrollers	<a href="http://microcontroller.ti.com">microcontroller.ti.com</a>
RFID	<a href="http://www.ti-rfid.com">www.ti-rfid.com</a>
OMAP Mobile Processors	<a href="http://www.ti.com/omap">www.ti.com/omap</a>
Wireless Connectivity	<a href="http://www.ti.com/wirelessconnectivity">www.ti.com/wirelessconnectivity</a>

### Applications

Automotive and Transportation	<a href="http://www.ti.com/automotive">www.ti.com/automotive</a>
Communications and Telecom	<a href="http://www.ti.com/communications">www.ti.com/communications</a>
Computers and Peripherals	<a href="http://www.ti.com/computers">www.ti.com/computers</a>
Consumer Electronics	<a href="http://www.ti.com/consumer-apps">www.ti.com/consumer-apps</a>
Energy and Lighting	<a href="http://www.ti.com/energy">www.ti.com/energy</a>
Industrial	<a href="http://www.ti.com/industrial">www.ti.com/industrial</a>
Medical	<a href="http://www.ti.com/medical">www.ti.com/medical</a>
Security	<a href="http://www.ti.com/security">www.ti.com/security</a>
Space, Avionics and Defense	<a href="http://www.ti.com/space-avionics-defense">www.ti.com/space-avionics-defense</a>
Video and Imaging	<a href="http://www.ti.com/video">www.ti.com/video</a>

**TI E2E Community** [e2e.ti.com](http://e2e.ti.com)