

SN54LVT16646, SN74LVT16646 3.3-V ABT 16-BIT BUS TRANSCEIVERS AND REGISTERS WITH 3-STATE OUTPUTS

SCBS149D – JULY 1994 – REVISED MARCH 2004

- **Members of the Texas Instruments Widebus™ Family**
- **State-of-the-Art Advanced BiCMOS Technology (ABT) Design for 3.3-V Operation and Low-Static Power Dissipation**
- **Support Mixed-Mode Signal Operation (5-V Input and Output Voltages With 3.3-V V_{CC})**
- **Support Unregulated Battery Operation Down to 2.7 V**
- **Typical V_{OLP} (Output Ground Bounce) <0.8 V at V_{CC} = 3.3 V, T_A = 25°C**
- **Bus-Hold Data Inputs Eliminate the Need for External Pullup Resistors**
- **I_{off} and Power-Up 3-State Support Hot Insertion**
- **Distributed V_{CC} and GND Pin Configuration Minimizes High-Speed Switching Noise**
- **Flowthrough Architecture Optimizes PCB Layout**
- **Latch-Up Performance Exceeds 500 mA Per JEDEC Standard JESD-17**
- **ESD Protection Exceeds JESD 22**
 - 2000-V Human-Body Model (A114-A)
 - 200-V Machine Model (A115-A)

SN54LVT16646 . . . WD PACKAGE
SN74LVT16646 . . . DGG OR DL PACKAGE
(TOP VIEW)

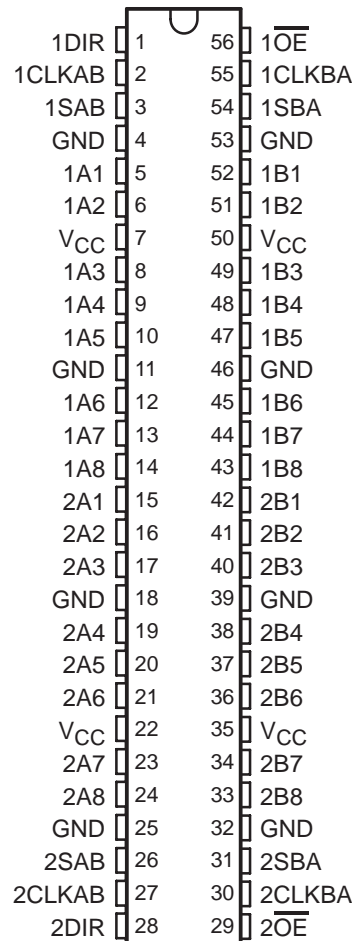

description/ordering information

The 'LVT16646 devices are 16-bit bus transceivers and registers designed for low-voltage (3.3-V) V_{CC} operation, but with the capability to provide a TTL interface to a 5-V system environment.

These devices can be used as two 8-bit transceivers or one 16-bit transceiver. Data on the A or B bus is clocked into the registers on the low-to-high transition of the appropriate clock (CLKAB or CLKBA) input. Figure 1 illustrates the four fundamental bus-management functions that can be performed with the 'LVT16646 devices.

ORDERING INFORMATION

T _A	PACKAGE†		ORDERABLE PART NUMBER	TOP-SIDE MARKING
–40°C to 85°C	SSOP – DL	Tube	SN74LVT16646DL	LVT16646
		Tape and reel	SN74LVT16646DLR	
	TSSOP – DGG	Tape and reel	SN74LVT16646DGGR	LVT16646
–55°C to 125°C	CFP – WD	Tube	SNJ54LVT16646WD	SNJ54LVT16646WD

† Package drawings, standard packing quantities, thermal data, symbolization, and PCB design guidelines are available at www.ti.com/sc/package.



Please be aware that an important notice concerning availability, standard warranty, and use in critical applications of Texas Instruments semiconductor products and disclaimers thereto appears at the end of this data sheet.

Widebus is a trademark of Texas Instruments.

UNLESS OTHERWISE NOTED this document contains PRODUCTION DATA information current as of publication date. Products conform to specifications per the terms of Texas Instruments standard warranty. Production processing does not necessarily include testing of all parameters.



POST OFFICE BOX 655303 • DALLAS, TEXAS 75265

Copyright © 2004, Texas Instruments Incorporated

SN54LVT16646, SN74LVT16646

3.3-V ABT 16-BIT BUS TRANSCEIVERS AND REGISTERS WITH 3-STATE OUTPUTS

SCBS149D – JULY 1994 – REVISED MARCH 2004

description/ordering information (continued)

Output-enable (\overline{OE}) and direction-control (DIR) inputs are provided to control the transceiver functions. In the transceiver mode, data present at the high-impedance port may be stored in either register or in both. The select-control (SAB and SBA) inputs can multiplex stored and real-time (transparent mode) data. The circuitry used for select control eliminates the typical decoding glitch that occurs in a multiplexer during the transition between stored and real-time data. The direction control (DIR) determines which bus receives data when \overline{OE} is low. In the isolation mode (\overline{OE} high), A data may be stored in one register and/or B data may be stored in the other register.

When an output function is disabled, the input function is still enabled and may be used to store and transmit data. Only one of the two buses, A or B, may be driven at a time.

Active bus-hold circuitry holds unused or undriven inputs at a valid logic state. Use of pullup or pulldown resistors with the bus-hold circuitry is not recommended.

These devices are fully specified for hot-insertion applications using I_{off} and power-up 3-state. The I_{off} circuitry disables the outputs, preventing damaging current backflow through the devices when they are powered down. The power-up 3-state circuitry places the outputs in the high-impedance state during power up and power down, which prevents driver conflict.

To ensure the high-impedance state during power up or power down, \overline{OE} should be tied to V_{CC} through a pullup resistor; the minimum value of the resistor is determined by the current-sinking capability of the driver.

FUNCTION TABLE

INPUTS						DATA I/Os		OPERATION OR FUNCTION
\overline{OE}	DIR	CLKAB	CLKBA	SAB	SBA	A1 THRU A8	B1 THRU B8	
X	X	↑	X	X	X	Input	Unspecified†	Store A, B unspecified†
X	X	X	↑	X	X	Unspecified†	Input	Store B, A unspecified†
H	X	↑	↑	X	X	Input	Input	Store A and B data
H	X	H or L	H or L	X	X	Input disabled	Input disabled	Isolation, hold storage
L	L	X	X	X	L	Output	Input	Real-time B data to A bus
L	L	X	H or L	X	H	Output	Input	Stored B data to A bus
L	H	X	X	L	X	Input	Output	Real-time A data to B bus
L	H	H or L	X	H	X	Input	Output	Stored A data to B bus

† The data output functions may be enabled or disabled by various signals at \overline{OE} and DIR. Data input functions always are enabled; i.e., data at the bus pins are stored on every low-to-high transition of the clock inputs.



SN54LVT16646, SN74LVT16646
3.3-V ABT 16-BIT BUS TRANSCEIVERS AND REGISTERS
WITH 3-STATE OUTPUTS

SCBS149D – JULY 1994 – REVISED MARCH 2004

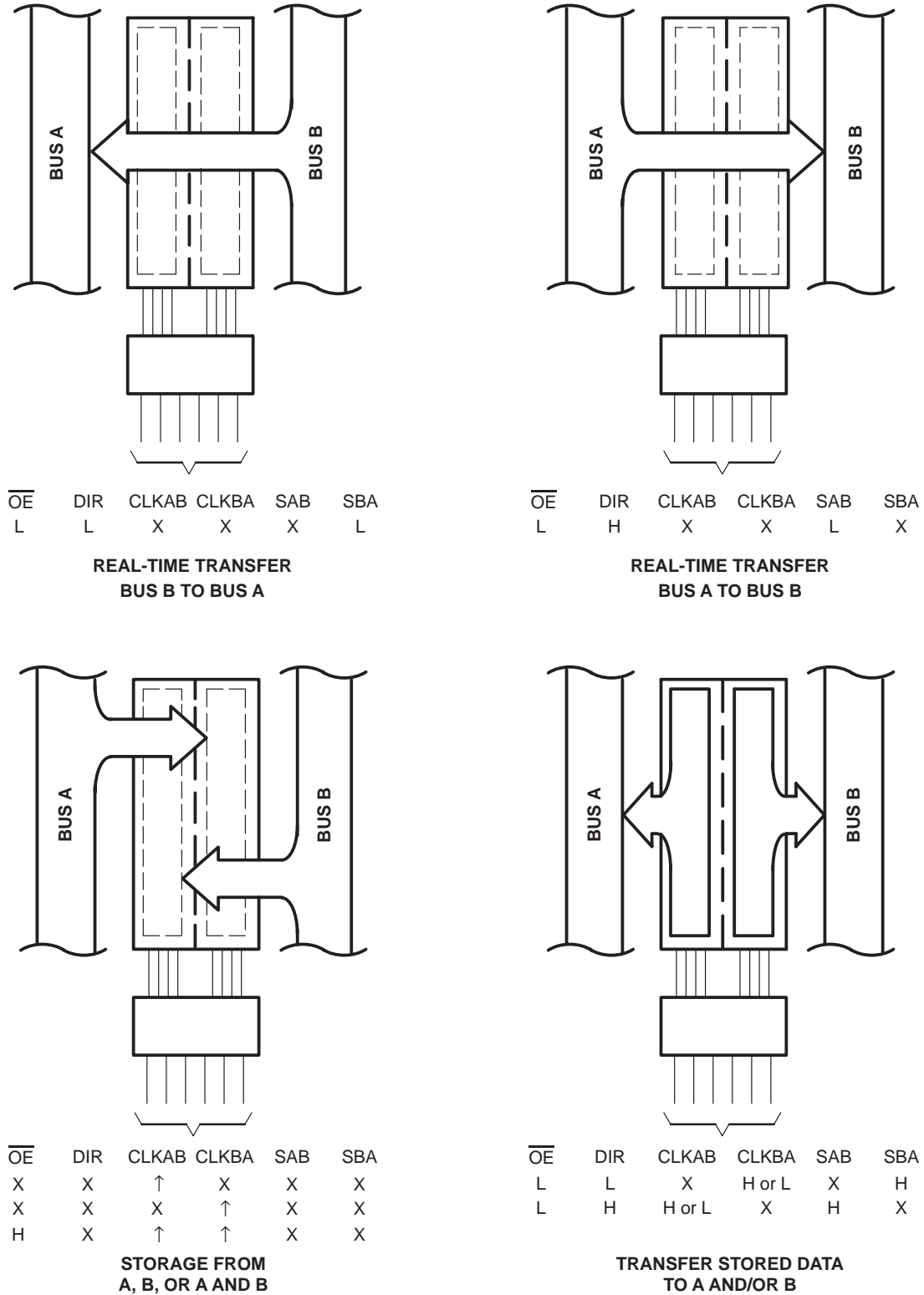

Figure 1. Bus-Management Functions

SN54LVT16646, SN74LVT16646

3.3-V ABT 16-BIT BUS TRANSCEIVERS AND REGISTERS WITH 3-STATE OUTPUTS

SCBS149D – JULY 1994 – REVISED MARCH 2004

logic diagram (positive logic)

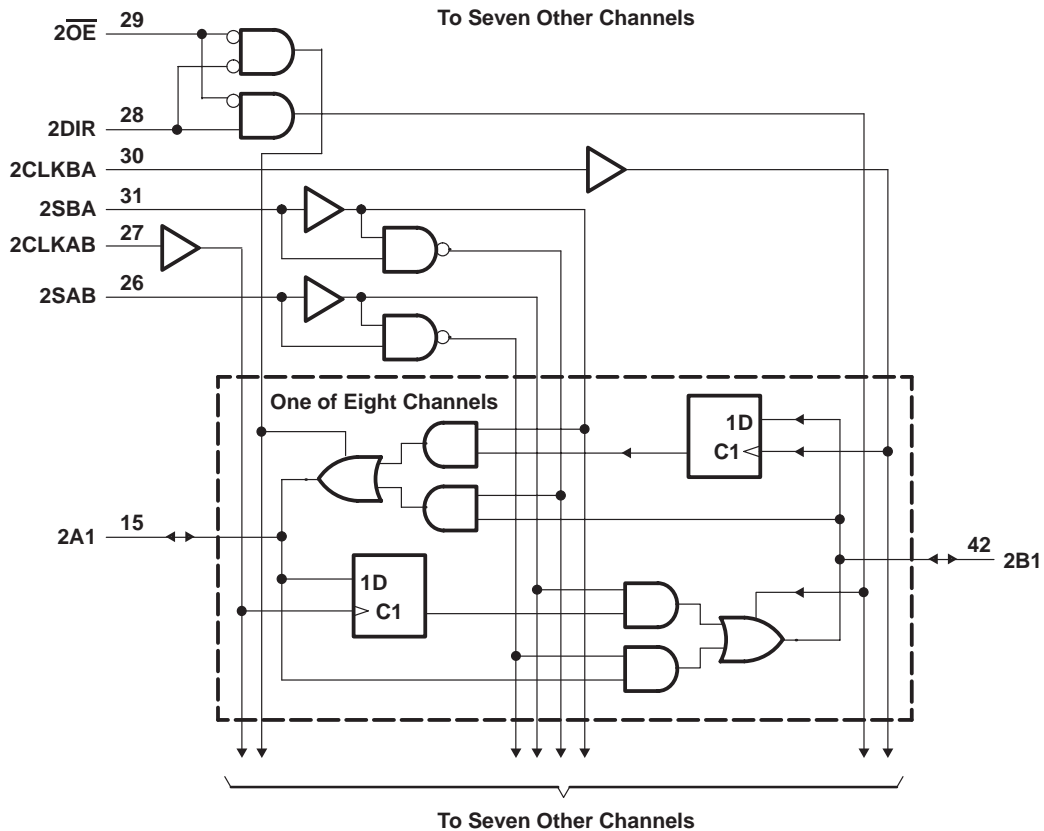
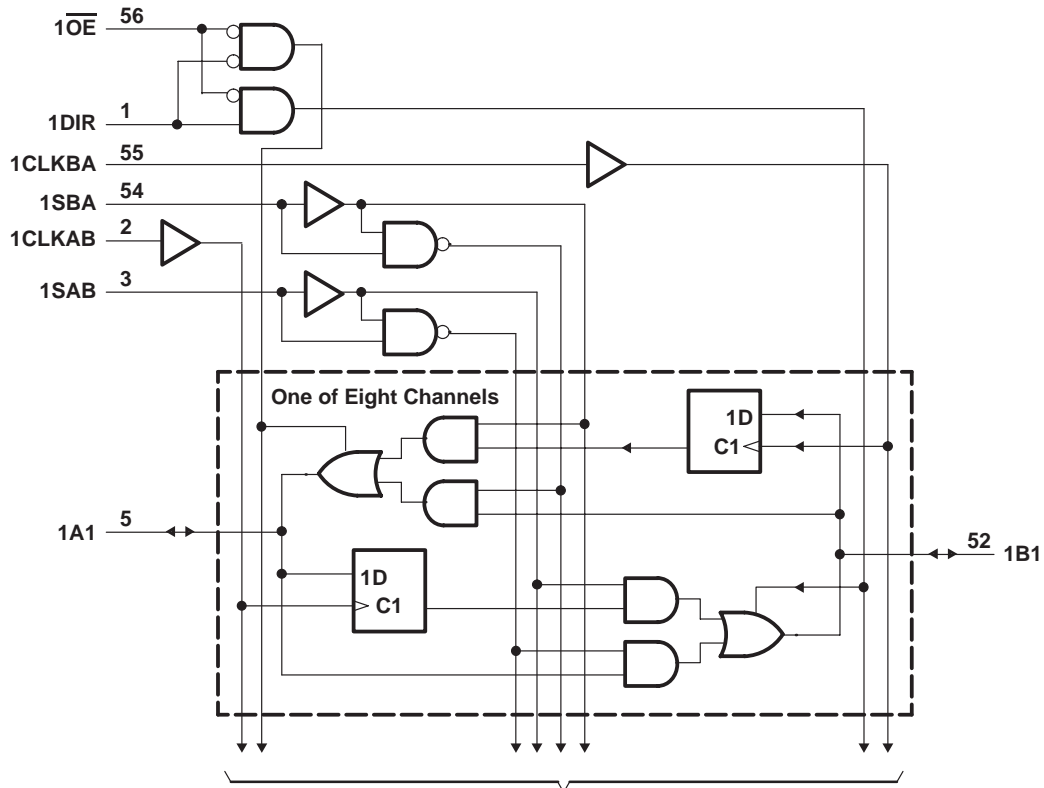

POST OFFICE BOX 655303 • DALLAS, TEXAS 75265

SN54LVT16646, SN74LVT16646 3.3-V ABT 16-BIT BUS TRANSCEIVERS AND REGISTERS WITH 3-STATE OUTPUTS

SCBS149D – JULY 1994 – REVISED MARCH 2004

absolute maximum ratings over operating free-air temperature range (unless otherwise noted)†

Supply voltage range, V_{CC}	–0.5 V to 4.6 V
Input voltage range, V_I (see Note 1)	–0.5 V to 7 V
Voltage range applied to any output in the high state or power-off state, V_O (see Note 1)	–0.5 V to 7 V
Current into any output in the low state, I_O : SN54LVT16646	96 mA
SN74LVT16646	128 mA
Current into any output in the high state, I_O (see Note 2): SN54LVT16646	48 mA
SN74LVT16646	64 mA
Input clamp current, I_{IK} ($V_I < 0$)	–50 mA
Output clamp current, I_{OK} ($V_O < 0$)	–50 mA
Package thermal impedance, θ_{JA} (see Note 3): DGG package	64°C/W
DL package	56°C/W
Storage temperature range, T_{stg}	–65°C to 150°C

† Stresses beyond those listed under “absolute maximum ratings” may cause permanent damage to the device. These are stress ratings only, and functional operation of the device at these or any other conditions beyond those indicated under “recommended operating conditions” is not implied. Exposure to absolute-maximum-rated conditions for extended periods may affect device reliability.

- NOTES: 1. The input and output negative-voltage ratings may be exceeded if the input and output clamp-current ratings are observed.
 2. This current flows only when the output is in the high state and $V_O > V_{CC}$.
 3. The package thermal impedance is calculated in accordance with JESD 51–7.

recommended operating conditions (see Note 4)

		SN54LVT16646		SN74LVT16646		UNIT
		MIN	MAX	MIN	MAX	
V_{CC}	Supply voltage	2.7	3.6	2.7	3.6	V
V_{IH}	High-level input voltage	2		2		V
V_{IL}	Low-level input voltage		0.8		0.8	V
V_I	Input voltage		5.5		5.5	V
I_{OH}	High-level output current		–24		–32	mA
I_{OL}	Low-level output current		48		64	mA
$\Delta t/\Delta v$	Input transition rise or fall rate	Outputs enabled			10	ns/V
T_A	Operating free-air temperature	–55	125	–40	85	°C

NOTE 4: All unused control inputs of the device must be held at V_{CC} or GND to ensure proper device operation. Refer to the TI application report, *Implications of Slow or Floating CMOS Inputs*, literature number SCBA004.

SN54LVT16646, SN74LVT16646

3.3-V ABT 16-BIT BUS TRANSCEIVERS AND REGISTERS WITH 3-STATE OUTPUTS

SCBS149D – JULY 1994 – REVISED MARCH 2004

electrical characteristics over recommended operating free-air temperature range (unless otherwise noted)

PARAMETER	TEST CONDITIONS		SN54LVT16646			SN74LVT16646			UNIT	
			MIN	TYP†	MAX	MIN	TYP†	MAX		
V_{IK}	$V_{CC} = 2.7\text{ V}$, $I_I = -18\text{ mA}$		-1.2			-1.2			V	
V_{OH}	$V_{CC} = \text{MIN to MAX}‡$, $I_{OH} = -100\text{ }\mu\text{A}$		$V_{CC} - 0.2$			$V_{CC} - 0.2$			V	
	$V_{CC} = 2.7\text{ V}$, $I_{OH} = -8\text{ mA}$		2.4			2.4				
	$V_{CC} = 3\text{ V}$	$I_{OH} = -24\text{ mA}$	2			2				
$I_{OH} = -32\text{ mA}$										
V_{OL}	$V_{CC} = 2.7\text{ V}$	$I_{OL} = 100\text{ }\mu\text{A}$	0.2			0.2			V	
		$I_{OL} = 24\text{ mA}$	0.5			0.5				
	$V_{CC} = 3\text{ V}$	$I_{OL} = 16\text{ mA}$	0.4			0.4				
		$I_{OL} = 32\text{ mA}$	0.5			0.5				
		$I_{OL} = 48\text{ mA}$	0.55			0.55				
		$I_{OL} = 64\text{ mA}$				0.55				
I_I	$V_{CC} = 3.6\text{ V}$, $V_I = V_{CC}$ or GND	Control inputs	± 1			± 1			μA	
			$V_{CC} = 0$ or $\text{MAX}‡$, $V_I = 5.5\text{ V}$	10			10			
	$V_{CC} = 3.6\text{ V}$	A or B ports§	$V_I = 5.5\text{ V}$	20			20			
			$V_I = V_{CC}$	5			5			
			$V_I = 0$	-10			-10			
I_{off}	$V_{CC} = 0$, V_I or $V_O = 0$ to 4.5 V					± 100			μA	
$I_{I(\text{hold})}$	$V_{CC} = 3\text{ V}$	A or B ports	$V_I = 0.8\text{ V}$	75			75			μA
			$V_I = 2\text{ V}$	-75			-75			
I_{OZH}	$V_{CC} = 3.6\text{ V}$, $V_O = 3\text{ V}$		1			1			μA	
I_{OZL}	$V_{CC} = 3.6\text{ V}$, $V_O = 0.5\text{ V}$		-1			-1			μA	
I_{CC}	$V_{CC} = 3.6\text{ V}$, $V_I = V_{CC}$ or GND	$I_O = 0$,	Outputs high	0.12			0.12			mA
			Outputs low	5			5			
			Outputs disabled	0.12			0.12			
$\Delta I_{CC}¶$	$V_{CC} = 3\text{ V to }3.6\text{ V}$, One input at $V_{CC} - 0.6\text{ V}$, Other inputs at V_{CC} or GND		0.2			0.2			mA	
C_i	$V_I = 3\text{ V}$ or 0		3.5			3.5			pF	
C_{io}	$V_O = 3\text{ V}$ or 0		12			12			pF	

† All typical values are at $V_{CC} = 3.3\text{ V}$, $T_A = 25^\circ\text{C}$.

‡ For conditions shown as MIN or MAX, use the appropriate value specified under recommended operating conditions.

§ Unused pins at V_{CC} or GND

¶ This is the increase in supply current for each input that is at the specified TTL voltage level, rather than V_{CC} or GND.

PRODUCT PREVIEW information concerns products in the formative or design phase of development. Characteristic data and other specifications are design goals. Texas Instruments reserves the right to change or discontinue these products without notice.



SN54LVT16646, SN74LVT16646 3.3-V ABT 16-BIT BUS TRANSCEIVERS AND REGISTERS WITH 3-STATE OUTPUTS

SCBS149D – JULY 1994 – REVISED MARCH 2004

timing requirements over recommended operating free-air temperature range (unless otherwise noted) (see Figure 2)

		SN54LVT16646				SN74LVT16646				UNIT
		V _{CC} = 3.3 V ± 0.3 V		V _{CC} = 2.7 V		V _{CC} = 3.3 V ± 0.3 V		V _{CC} = 2.7 V		
		MIN	MAX	MIN	MAX	MIN	MAX	MIN	MAX	
f _{clock}	Clock frequency	150		150		150		150		MHz
t _w	Pulse duration, CLK high or low	3.3		3.3		3.3		3.3		ns
t _{su}	Setup time, A or B before CLKAB↑ or CLKBA↑	Data high	1.3	1.4	1.3	1.4	2.4	3	ns	
		Data low	2.4	3	2.4	3				
t _h	Hold time, A or B after CLKAB↑ or CLKBA↑	Data high	0.5	0	0.5	0	0.5	0	ns	
		Data low	0.6	0.5	0.5	0.5				

switching characteristics over recommended operating free-air temperature range, C_L = 50 pF (unless otherwise noted) (see Figure 2)

PARAMETER	FROM (INPUT)	TO (OUTPUT)	SN54LVT16646				SN74LVT16646				UNIT	
			V _{CC} = 3.3 V ± 0.3 V		V _{CC} = 2.7 V		V _{CC} = 3.3 V ± 0.3 V			V _{CC} = 2.7 V		
			MIN	MAX	MIN	MAX	MIN	TYP†	MAX	MIN		MAX
f _{max}			150				150					MHz
t _{PLH}	CLKBA or CLKAB	A or B	1.8	6	6.9		1.8	3.8	5.7	6.7		ns
t _{PHL}			2.1	5.9	6.6		2.1	3.9	5.7	6.5		
t _{PLH}	A or B	B or A	1.3	4.9	5.6		1.3	3	4.7	5.4		ns
t _{PHL}			1	4.8	5.8		1	3.1	4.7	5.6		
t _{PLH}	SBA or SAB‡	A or B	1.4	6.4	7.4		1.4	4	6.2	7.2		ns
t _{PHL}			1.4	6.4	7.4		1.4	4.3	6.2	7.2		
t _{PZH}	$\overline{\text{OE}}$	A or B	1	5.7	7.4		1	3	5.4	6.4		ns
t _{PZL}			1	6.5	7.5		1	3.1	5.6	6.5		
t _{PHZ}	$\overline{\text{OE}}$	A or B	2.3	6.7	7.1		2.3	4.6	6.5	6.9		ns
t _{PLZ}			2.2	6	6.5		2.2	4.5	5.8	5.9		
t _{PZH}	DIR	A or B	1	5.9	7.7		1	3.3	5.7	6.7		ns
t _{PZL}			1.2	5.9	7.3		1.2	3.5	5.8	6.7		
t _{PHZ}	DIR	A or B	1.7	7.3	8.5		1.7	4.7	7.2	8.3		ns
t _{PLZ}			1.5	7.8	7.4		1.5	4.9	6.6	7.2		

† All typical values are at V_{CC} = 3.3 V, T_A = 25°C.

‡ These parameters are measured with the internal output state of the storage register opposite to that of the bus input.

PRODUCT PREVIEW information concerns products in the formative or design phase of development. Characteristic data and other specifications are design goals. Texas Instruments reserves the right to change or discontinue these products without notice.



POST OFFICE BOX 655303 • DALLAS, TEXAS 75265

SN54LVT16646, SN74LVT16646 3.3-V ABT 16-BIT BUS TRANSCEIVERS AND REGISTERS WITH 3-STATE OUTPUTS

SCBS149D – JULY 1994 – REVISED MARCH 2004

PARAMETER MEASUREMENT INFORMATION

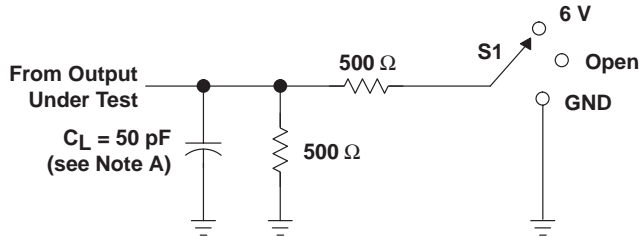

TEST	S1
t_{PLH}/t_{PHL}	Open
t_{PLZ}/t_{PZL}	6 V
t_{PHZ}/t_{PZH}	GND

LOAD CIRCUIT FOR OUTPUTS

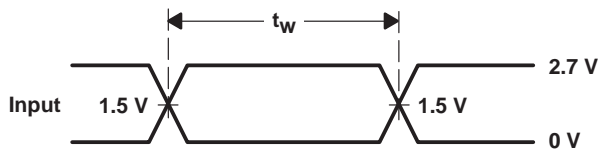

VOLTAGE WAVEFORMS
PULSE DURATION

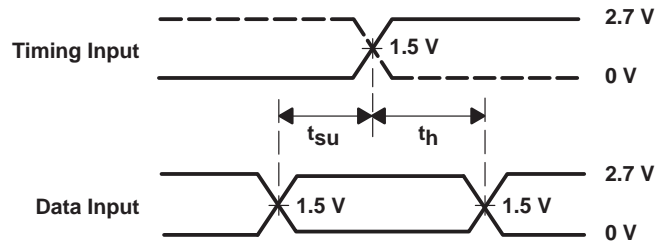

VOLTAGE WAVEFORMS
SETUP AND HOLD TIMES

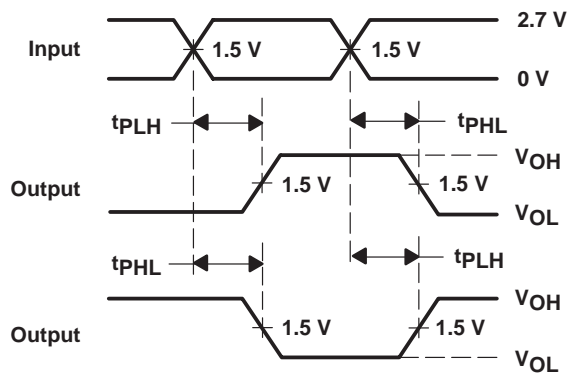

VOLTAGE WAVEFORMS
PROPAGATION DELAY TIMES
INVERTING AND NONINVERTING OUTPUTS

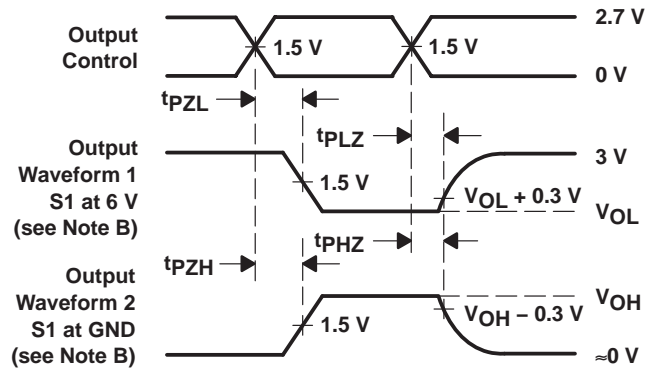

VOLTAGE WAVEFORMS
ENABLE AND DISABLE TIMES
LOW- AND HIGH-LEVEL ENABLING

- NOTES: A. C_L includes probe and jig capacitance.
 B. Waveform 1 is for an output with internal conditions such that the output is low, except when disabled by the output control. Waveform 2 is for an output with internal conditions such that the output is high, except when disabled by the output control.
 C. All input pulses are supplied by generators having the following characteristics: $PRR \leq 10$ MHz, $Z_O = 50 \Omega$, $t_r \leq 2.5$ ns, $t_f \leq 2.5$ ns.
 D. The outputs are measured one at a time, with one transition per measurement.
 E. All parameters and waveforms are not applicable to all devices.

Figure 2. Load Circuit and Voltage Waveforms

PACKAGING INFORMATION

Orderable Device	Status ⁽¹⁾	Package Type	Package Drawing	Pins	Package Qty	Eco Plan ⁽²⁾	Lead/Ball Finish	MSL Peak Temp ⁽³⁾
74LVT16646DGGRE4	ACTIVE	TSSOP	DGG	56		TBD	Call TI	Call TI
SN74LVT16646DGGR	NRND	TSSOP	DGG	56	2000	Pb-Free (RoHS)	CU NIPDAU	Level-1-250C-UNLIM
SN74LVT16646DL	NRND	SSOP	DL	56	20	Green (RoHS & no Sb/Br)	CU NIPDAU	Level-1-260C-UNLIM
SN74LVT16646DLR	NRND	SSOP	DL	56	1000	Green (RoHS & no Sb/Br)	CU NIPDAU	Level-1-260C-UNLIM

⁽¹⁾ The marketing status values are defined as follows:

ACTIVE: Product device recommended for new designs.

LIFEBUY: TI has announced that the device will be discontinued, and a lifetime-buy period is in effect.

NRND: Not recommended for new designs. Device is in production to support existing customers, but TI does not recommend using this part in a new design.

PREVIEW: Device has been announced but is not in production. Samples may or may not be available.

OBSOLETE: TI has discontinued the production of the device.

⁽²⁾ Eco Plan - The planned eco-friendly classification: Pb-Free (RoHS), Pb-Free (RoHS Exempt), or Green (RoHS & no Sb/Br) - please check <http://www.ti.com/productcontent> for the latest availability information and additional product content details.

TBD: The Pb-Free/Green conversion plan has not been defined.

Pb-Free (RoHS): TI's terms "Lead-Free" or "Pb-Free" mean semiconductor products that are compatible with the current RoHS requirements for all 6 substances, including the requirement that lead not exceed 0.1% by weight in homogeneous materials. Where designed to be soldered at high temperatures, TI Pb-Free products are suitable for use in specified lead-free processes.

Pb-Free (RoHS Exempt): This component has a RoHS exemption for either 1) lead-based flip-chip solder bumps used between the die and package, or 2) lead-based die adhesive used between the die and leadframe. The component is otherwise considered Pb-Free (RoHS compatible) as defined above.

Green (RoHS & no Sb/Br): TI defines "Green" to mean Pb-Free (RoHS compatible), and free of Bromine (Br) and Antimony (Sb) based flame retardants (Br or Sb do not exceed 0.1% by weight in homogeneous material)

⁽³⁾ MSL, Peak Temp. -- The Moisture Sensitivity Level rating according to the JEDEC industry standard classifications, and peak solder temperature.

Important Information and Disclaimer:The information provided on this page represents TI's knowledge and belief as of the date that it is provided. TI bases its knowledge and belief on information provided by third parties, and makes no representation or warranty as to the accuracy of such information. Efforts are underway to better integrate information from third parties. TI has taken and continues to take reasonable steps to provide representative and accurate information but may not have conducted destructive testing or chemical analysis on incoming materials and chemicals. TI and TI suppliers consider certain information to be proprietary, and thus CAS numbers and other limited information may not be available for release.

In no event shall TI's liability arising out of such information exceed the total purchase price of the TI part(s) at issue in this document sold by TI to Customer on an annual basis.

TAPE AND REEL INFORMATION

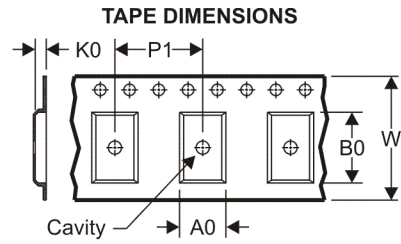
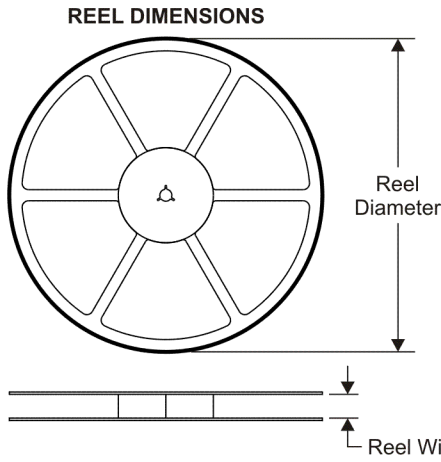

A0	Dimension designed to accommodate the component width
B0	Dimension designed to accommodate the component length
K0	Dimension designed to accommodate the component thickness
W	Overall width of the carrier tape
P1	Pitch between successive cavity centers

QUADRANT ASSIGNMENTS FOR PIN 1 ORIENTATION IN TAPE

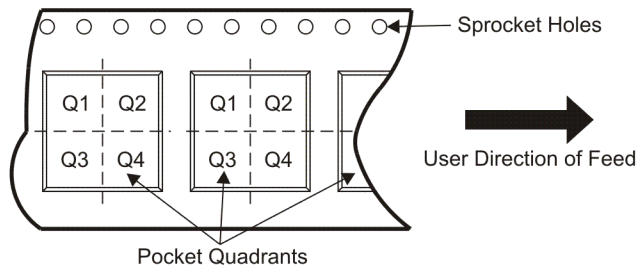

*All dimensions are nominal

Device	Package Type	Package Drawing	Pins	SPQ	Reel Diameter (mm)	Reel Width W1 (mm)	A0 (mm)	B0 (mm)	K0 (mm)	P1 (mm)	W (mm)	Pin1 Quadrant
SN74LVT16646DGGR	TSSOP	DGG	56	2000	330.0	24.4	8.6	15.6	1.8	12.0	24.0	Q1
SN74LVT16646DLR	SSOP	DL	56	1000	330.0	32.4	11.35	18.67	3.1	16.0	32.0	Q1

TAPE AND REEL BOX DIMENSIONS

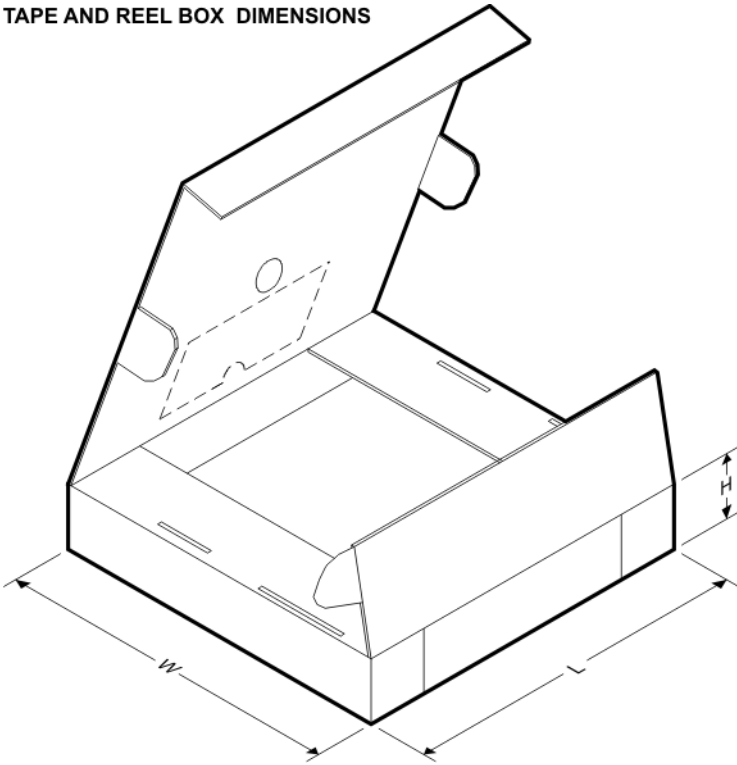

*All dimensions are nominal

Device	Package Type	Package Drawing	Pins	SPQ	Length (mm)	Width (mm)	Height (mm)
SN74LVT16646DGGR	TSSOP	DGG	56	2000	346.0	346.0	41.0
SN74LVT16646DLR	SSOP	DL	56	1000	346.0	346.0	49.0

DGG (R-PDSO-G**)

PLASTIC SMALL-OUTLINE PACKAGE

48 PINS SHOWN



- NOTES: A. All linear dimensions are in millimeters.
 B. This drawing is subject to change without notice.
 C. Body dimensions do not include mold protrusion not to exceed 0,15.
 D. Falls within JEDEC MO-153

DL (R-PDSO-G**)

PLASTIC SMALL-OUTLINE PACKAGE

48 PINS SHOWN



- NOTES: A. All linear dimensions are in inches (millimeters).
 B. This drawing is subject to change without notice.
 C. Body dimensions do not include mold flash or protrusion not to exceed 0.006 (0,15).
 D. Falls within JEDEC MO-118

IMPORTANT NOTICE

Texas Instruments Incorporated and its subsidiaries (TI) reserve the right to make corrections, modifications, enhancements, improvements, and other changes to its products and services at any time and to discontinue any product or service without notice. Customers should obtain the latest relevant information before placing orders and should verify that such information is current and complete. All products are sold subject to TI's terms and conditions of sale supplied at the time of order acknowledgment.

TI warrants performance of its hardware products to the specifications applicable at the time of sale in accordance with TI's standard warranty. Testing and other quality control techniques are used to the extent TI deems necessary to support this warranty. Except where mandated by government requirements, testing of all parameters of each product is not necessarily performed.

TI assumes no liability for applications assistance or customer product design. Customers are responsible for their products and applications using TI components. To minimize the risks associated with customer products and applications, customers should provide adequate design and operating safeguards.

TI does not warrant or represent that any license, either express or implied, is granted under any TI patent right, copyright, mask work right, or other TI intellectual property right relating to any combination, machine, or process in which TI products or services are used. Information published by TI regarding third-party products or services does not constitute a license from TI to use such products or services or a warranty or endorsement thereof. Use of such information may require a license from a third party under the patents or other intellectual property of the third party, or a license from TI under the patents or other intellectual property of TI.

Reproduction of TI information in TI data books or data sheets is permissible only if reproduction is without alteration and is accompanied by all associated warranties, conditions, limitations, and notices. Reproduction of this information with alteration is an unfair and deceptive business practice. TI is not responsible or liable for such altered documentation. Information of third parties may be subject to additional restrictions.

Resale of TI products or services with statements different from or beyond the parameters stated by TI for that product or service voids all express and any implied warranties for the associated TI product or service and is an unfair and deceptive business practice. TI is not responsible or liable for any such statements.

TI products are not authorized for use in safety-critical applications (such as life support) where a failure of the TI product would reasonably be expected to cause severe personal injury or death, unless officers of the parties have executed an agreement specifically governing such use. Buyers represent that they have all necessary expertise in the safety and regulatory ramifications of their applications, and acknowledge and agree that they are solely responsible for all legal, regulatory and safety-related requirements concerning their products and any use of TI products in such safety-critical applications, notwithstanding any applications-related information or support that may be provided by TI. Further, Buyers must fully indemnify TI and its representatives against any damages arising out of the use of TI products in such safety-critical applications.

TI products are neither designed nor intended for use in military/aerospace applications or environments unless the TI products are specifically designated by TI as military-grade or "enhanced plastic." Only products designated by TI as military-grade meet military specifications. Buyers acknowledge and agree that any such use of TI products which TI has not designated as military-grade is solely at the Buyer's risk, and that they are solely responsible for compliance with all legal and regulatory requirements in connection with such use.

TI products are neither designed nor intended for use in automotive applications or environments unless the specific TI products are designated by TI as compliant with ISO/TS 16949 requirements. Buyers acknowledge and agree that, if they use any non-designated products in automotive applications, TI will not be responsible for any failure to meet such requirements.

Following are URLs where you can obtain information on other Texas Instruments products and application solutions:

Products

Amplifiers	amplifier.ti.com
Data Converters	dataconverter.ti.com
DSP	dsp.ti.com
Clocks and Timers	www.ti.com/clocks
Interface	interface.ti.com
Logic	logic.ti.com
Power Mgmt	power.ti.com
Microcontrollers	microcontroller.ti.com
RFID	www.ti-rfid.com
RF/IF and ZigBee® Solutions	www.ti.com/lprf

Applications

Audio	www.ti.com/audio
Automotive	www.ti.com/automotive
Broadband	www.ti.com/broadband
Digital Control	www.ti.com/digitalcontrol
Medical	www.ti.com/medical
Military	www.ti.com/military
Optical Networking	www.ti.com/opticalnetwork
Security	www.ti.com/security
Telephony	www.ti.com/telephony
Video & Imaging	www.ti.com/video
Wireless	www.ti.com/wireless

Mailing Address: Texas Instruments, Post Office Box 655303, Dallas, Texas 75265
Copyright © 2008, Texas Instruments Incorporated