

SN54LVT16501, SN74LVT16501 3.3-V ABT 18-BIT UNIVERSAL BUS TRANSCEIVERS WITH 3-STATE OUTPUTS

SCBS147G – MAY 1992 – REVISED NOVEMBER 1996

- State-of-the-Art Advanced BiCMOS Technology (ABT) Design for 3.3-V Operation and Low-Static Power Dissipation
- Members of the Texas Instruments *Widebus™* Family
- Support Mixed-Mode Signal Operation (5-V Input and Output Voltages With 3.3-V V_{CC})
- Support Unregulated Battery Operation Down to 2.7 V
- *UBT™* (Universal Bus Transceiver) Combines D-Type Latches and D-Type Flip-Flops for Operation in Transparent, Latched, or Clocked Mode
- Typical V_{OLP} (Output Ground Bounce) < 0.8 V at $V_{CC} = 3.3$ V, $T_A = 25^\circ\text{C}$
- ESD Protection Exceeds 2000 V Per MIL-STD-883, Method 3015; Exceeds 200 V Using Machine Model ($C = 200$ pF, $R = 0$)
- Latch-Up Performance Exceeds 500 mA Per JEDEC Standard JESD-17
- Bus Hold on Data Inputs Eliminates the Need for External Pullup/Pulldown Resistors
- Support Live Insertion
- Distributed V_{CC} and GND Pin Configuration Minimizes High-Speed Switching Noise
- Flow-Through Architecture Optimizes PCB Layout
- Package Options Include Plastic 300-mil Shrink Small-Outline (DL) and Thin Shrink Small-Outline (DGG) Packages and 380-mil Fine-Pitch Ceramic Flat (WD) Package Using 25-mil Center-to-Center Spacings

SN54LVT16501 . . . WD PACKAGE
SN74LVT16501 . . . DGG OR DL PACKAGE
(TOP VIEW)

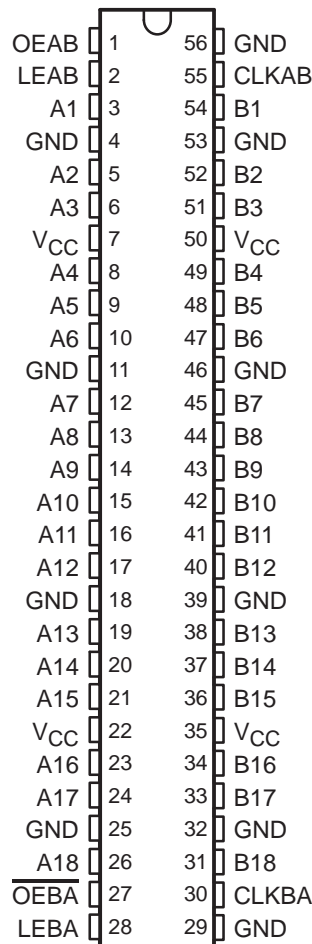

description

The 'LVT16501 are 18-bit universal bus transceivers designed for low-voltage (3.3-V) V_{CC} operation, but with the capability to provide a TTL interface to a 5-V system environment.

Data flow in each direction is controlled by output-enable (OEAB and \overline{OEBA}), latch-enable (LEAB and LEBA), and clock (CLKAB and CLKBA) inputs. For A-to-B data flow, the devices operate in the transparent mode when LEAB is high. When LEAB is low, the A data is latched if CLKAB is held at a high or low logic level. If LEAB is low, the A-bus data is stored in the latch/flip-flop on the low-to-high transition of CLKAB. When OEAB is high, the outputs are active. When OEAB is low, the outputs are in the high-impedance state.



Please be aware that an important notice concerning availability, standard warranty, and use in critical applications of Texas Instruments semiconductor products and disclaimers thereto appears at the end of this data sheet.

Widebus and UBT are trademarks of Texas Instruments Incorporated.

PRODUCTION DATA information is current as of publication date. Products conform to specifications per the terms of Texas Instruments standard warranty. Production processing does not necessarily include testing of all parameters.

 **TEXAS
INSTRUMENTS**

POST OFFICE BOX 655303 • DALLAS, TEXAS 75265

Copyright © 1996, Texas Instruments Incorporated

SN54LVT16501, SN74LVT16501

3.3-V ABT 18-BIT UNIVERSAL BUS TRANSCEIVERS

WITH 3-STATE OUTPUTS

SCBS147G – MAY 1992 – REVISED NOVEMBER 1996

description (continued)

Data flow for B to A is similar to that of A to B but uses \overline{OEBA} , LEBA, and CLKBA. The output enables are complementary (OEAB is active high and \overline{OEBA} is active low).

Active bus-hold circuitry is provided to hold unused or floating data inputs at a valid logic level.

To ensure the high-impedance state during power up or power down, \overline{OE} should be tied to V_{CC} through a pullup resistor. The minimum value of the resistor is determined by the current-sinking capability of the driver. OE should be tied to GND through a pulldown resistor; the minimum value of the resistor is determined by the current-sourcing capability of the driver.

The SN74LVT16501 is available in TI's shrink small-outline (DL) and thin shrink small-outline (DGG) packages, which provide twice the input/output (I/O) pin count and functionality of standard small-outline packages in the same printed circuit board area.

The SN54LVT16501 is characterized for operation over the full military temperature range of -55°C to 125°C . The SN74LVT16501 is characterized for operation from -40°C to 85°C .

FUNCTION TABLE†

INPUTS				OUTPUT
OEAB	LEAB	CLKAB	A	B
L	X	X	X	Z
H	H	X	L	L
H	H	X	H	H
H	L	↑	L	L
H	L	↑	H	H
H	L	H	X	B_0^{\ddagger}
H	L	L	X	B_0^{\S}

† A-to-B data flow is shown; B-to-A flow is similar but uses \overline{OEBA} , LEBA, and CLKBA.

‡ Output level before the indicated steady-state input conditions were established, provided that CLKAB was high before LEAB went low

§ Output level before the indicated steady-state input conditions were established



SN54LVT16501, SN74LVT16501 3.3-V ABT 18-BIT UNIVERSAL BUS TRANSCEIVERS WITH 3-STATE OUTPUTS

SCBS147G – MAY 1992 – REVISED NOVEMBER 1996

logic symbol†

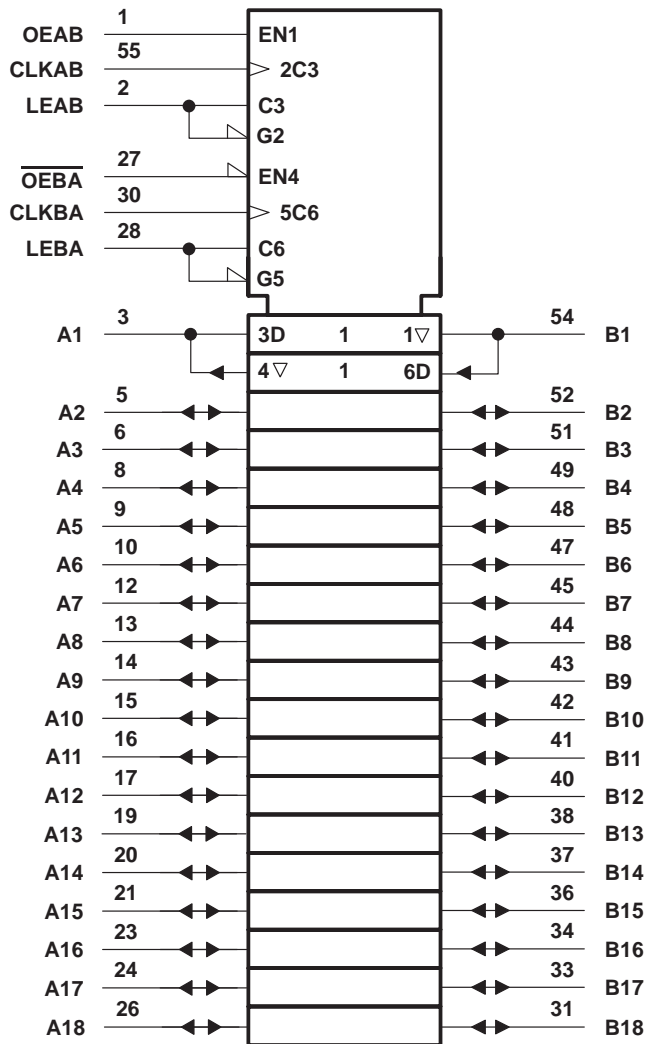

† This symbol is in accordance with ANSI/IEEE Std 91-1984 and IEC Publication 617-12.

SN54LVT16501, SN74LVT16501 3.3-V ABT 18-BIT UNIVERSAL BUS TRANSCEIVERS WITH 3-STATE OUTPUTS

SCBS147G – MAY 1992 – REVISED NOVEMBER 1996

recommended operating conditions (see Note 4)

		SN54LVT16501		SN74LVT16501		UNIT
		MIN	MAX	MIN	MAX	
V_{CC}	Supply voltage	2.7	3.6	2.7	3.6	V
V_{IH}	High-level input voltage	2		2		V
V_{IL}	Low-level input voltage		0.8		0.8	V
V_I	Input voltage		5.5		5.5	V
I_{OH}	High-level output current		-24		-32	mA
I_{OL}	Low-level output current		48		64	mA
$\Delta t/\Delta v$	Input transition rise or fall rate	Outputs enabled		10	10	ns/V
T_A	Operating free-air temperature	-55	125	-40	85	°C

NOTE 4: Unused control inputs must be held high or low to prevent them from floating.

SN54LVT16501, SN74LVT16501
3.3-V ABT 18-BIT UNIVERSAL BUS TRANSCEIVERS
WITH 3-STATE OUTPUTS

SCBS147G – MAY 1992 – REVISED NOVEMBER 1996

electrical characteristics over recommended operating free-air temperature range (unless otherwise noted)

PARAMETER	TEST CONDITIONS		SN54LVT16501			SN74LVT16501			UNIT	
			MIN	TYP†	MAX	MIN	TYP†	MAX		
V _{IK}	V _{CC} = 2.7 V, I _I = -18 mA		-1.2			-1.2			V	
V _{OH}	V _{CC} = 2.7 V to 3.6 V, I _{OH} = -100 μA		V _{CC} -0.2			V _{CC} -0.2			V	
	V _{CC} = 2.7 V, I _{OH} = -8 mA		2.4			2.4				
	V _{CC} = 3 V	I _{OH} = -24 mA	2							
I _{OH} = -32 mA					2					
V _{OL}	V _{CC} = 2.7 V	I _{OL} = 100 μA	0.2			0.2			V	
		I _{OL} = 24 mA	0.5			0.5				
	V _{CC} = 3 V	I _{OL} = 16 mA	0.4			0.4				
		I _{OL} = 32 mA	0.5			0.5				
		I _{OL} = 48 mA	0.55							
		I _{OL} = 64 mA				0.55				
I _I	Control pins	V _{CC} = 3.6 V, V _I = V _{CC} or GND	±1			±1			μA	
		V _{CC} = 0 or 3.6 V, V _I = 5.5 V	10			10				
	A or B ports‡	V _{CC} = 3.6 V	V _I = 5.5 V	120			20			
			V _I = V _{CC}	1			1			
		V _I = 0	-5			-5				
I _{off}	V _{CC} = 0, V _I or V _O = 0 to 4.5 V					±100			μA	
I _I (hold)	A or B ports	V _{CC} = 3 V	V _I = 0.8 V	75			75			μA
			V _I = 2 V	-75			-75			
I _{OZH}	V _{CC} = 3.6 V, V _O = 3 V					1			μA	
I _{OZL}	V _{CC} = 3.6 V, V _O = 0.5 V					-1			μA	
I _{CC}	V _{CC} = 3.6 V, V _I = V _{CC} or GND	I _O = 0,	Outputs high	0.12			0.12			mA
			Outputs low	5			5			
			Outputs disabled	0.12			0.12			
ΔI _{CC} §	V _{CC} = 3 V to 3.6 V, One input at V _{CC} - 0.6 V, Other inputs at V _{CC} or GND		0.2			0.2			mA	
C _i	V _I = 3 V or 0		3.5			3.5			pF	
C _{io}	V _O = 3 V or 0		12			12			pF	

† All typical values are at V_{CC} = 3.3 V, T_A = 25°C.

‡ Unused pins at V_{CC} or GND

§ This is the increase in supply current for each input that is at the specified TTL voltage level rather than V_{CC} or GND.



SN54LVT16501, SN74LVT16501
3.3-V ABT 18-BIT UNIVERSAL BUS TRANSCEIVERS
WITH 3-STATE OUTPUTS

SCBS147G – MAY 1992 – REVISED NOVEMBER 1996

timing requirements over recommended operating free-air temperature range (unless otherwise noted) (see Figure 1)

		SN54LVT16501				SN74LVT16501				UNIT
		$V_{CC} = 3.3\text{ V} \pm 0.3\text{ V}$		$V_{CC} = 2.7\text{ V}$		$V_{CC} = 3.3\text{ V} \pm 0.3\text{ V}$		$V_{CC} = 2.7\text{ V}$		
		MIN	MAX	MIN	MAX	MIN	MAX	MIN	MAX	
f_{clock}	Clock frequency	0	150	0	125	0	150	0	125	MHz
t_w	Pulse duration	LE high	3.3	3.3	3.3	3.3	3.3	3.3	3.3	ns
		CLK high or low	3.3	3.3	3.3	3.3	3.3	3.3	3.3	
t_{su}	Setup time	A before CLKAB \uparrow	1.6	2.1	1.6	2.1	1.6	2.1	ns	
		B before CLKBA \uparrow	1.6	2.1	1.6	2.1	1.6	2.1		
		A or B before LE \downarrow , $\overline{\text{CLK}}$ high	3.1	2.7	2.6	1.9	2.6	1.9		
		A or B before LE \downarrow , $\overline{\text{CLK}}$ low	2.6	2.0	2	1.3	2.6	1.3		
t_h	Hold time	A or B after CLK \uparrow	2	2.1	2	2.1	2	2.1	ns	
		A or B after LE \downarrow	1.3	1.2	0.9	1.2	1.3	1.2		

switching characteristics over recommended operating free-air temperature range, $C_L = 50\text{ pF}$ (unless otherwise noted) (see Figure 1)

PARAMETER	FROM (INPUT)	TO (OUTPUT)	SN54LVT16501				SN74LVT16501				UNIT	
			$V_{CC} = 3.3\text{ V} \pm 0.3\text{ V}$		$V_{CC} = 2.7\text{ V}$		$V_{CC} = 3.3\text{ V} \pm 0.3\text{ V}$			$V_{CC} = 2.7\text{ V}$		
			MIN	MAX	MIN	MAX	MIN	TYP \dagger	MAX	MIN		MAX
f_{max}			150		125			150		125	MHz	
t_{PLH}	B or A	A or B	1.7	5.4		6.8	1.7	3	5.4		6.8	ns
t_{PHL}			1.6	6		7.8	1.6	3.2	5.9		7.7	
t_{PLH}	LEBA or LEAB	A or B	2.3	7.3		9	2.3	4	7		8.5	ns
t_{PHL}			2.7	8.2		9.8	2.7	4.3	7.9		9.7	
t_{PLH}	CLKBA or CLKAB	A or B	2.5	8.3		9.7	2.5	4.1	7.9		9.2	ns
t_{PHL}			3.5	9.4		10.7	3.5	5.4	8.9		10.4	
t_{PZH}	$\overline{\text{OEBA}}$ or OEAB	A or B	1.2	5.1		6.1	1.2	3	5		5.9	ns
t_{PZL}			1.5	5.9		7	1.5	3	5.8		6.9	
t_{PHZ}	$\overline{\text{OEBA}}$ or OEAB	A or B	2.7	7.5		8.5	2.7	4.6	7.4		8.3	ns
t_{PLZ}			2.8	6.8		7.5	2.8	4.7	6.7		7.2	

\dagger All typical values are at $V_{CC} = 3.3\text{ V}$, $T_A = 25^\circ\text{C}$.

SN54LVT16501, SN74LVT16501
3.3-V ABT 18-BIT UNIVERSAL BUS TRANSCEIVERS
WITH 3-STATE OUTPUTS

SCBS147G – MAY 1992 – REVISED NOVEMBER 1996

PARAMETER MEASUREMENT INFORMATION

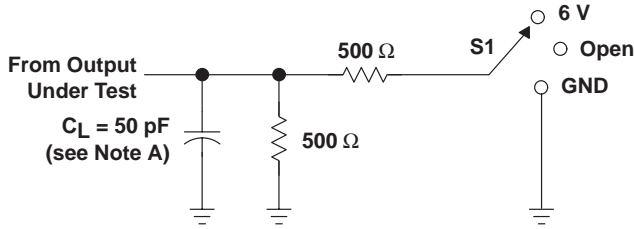

LOAD CIRCUIT

TEST	S1
t_{PLH}/t_{PHL}	Open
t_{PLZ}/t_{PZL}	6 V
t_{PHZ}/t_{PZH}	GND

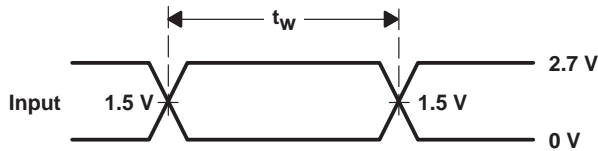

VOLTAGE WAVEFORMS
PULSE DURATION

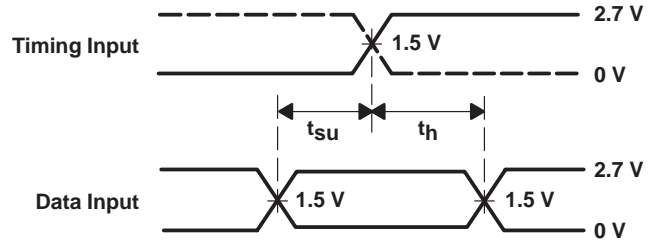

VOLTAGE WAVEFORMS
SETUP AND HOLD TIMES

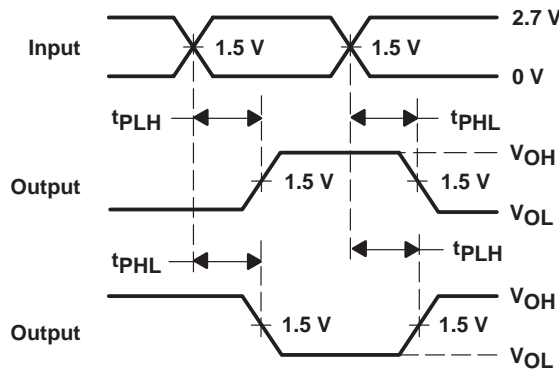

VOLTAGE WAVEFORMS
PROPAGATION DELAY TIMES
INVERTING AND NONINVERTING OUTPUTS

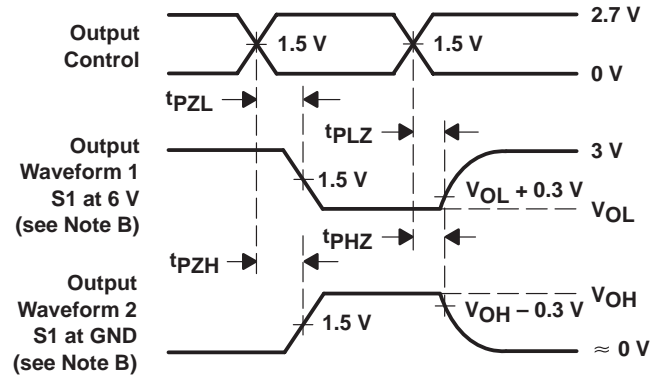

VOLTAGE WAVEFORMS
ENABLE AND DISABLE TIMES
LOW- AND HIGH-LEVEL ENABLING

- NOTES: A. C_L includes probe and jig capacitance.
 B. Waveform 1 is for an output with internal conditions such that the output is low except when disabled by the output control. Waveform 2 is for an output with internal conditions such that the output is high except when disabled by the output control.
 C. All input pulses are supplied by generators having the following characteristics: $PRR \leq 10 \text{ MHz}$, $Z_O = 50 \Omega$, $t_r \leq 2.5 \text{ ns}$, $t_f \leq 2.5 \text{ ns}$.
 D. The outputs are measured one at a time with one transition per measurement.

Figure 1. Load Circuit and Voltage Waveforms

PACKAGING INFORMATION

Orderable Device	Status ⁽¹⁾	Package Type	Package Drawing	Pins	Package Qty	Eco Plan ⁽²⁾	Lead/Ball Finish	MSL Peak Temp ⁽³⁾
74LVT16501DGGRE4	NRND	TSSOP	DGG	56	2000	Pb-Free (RoHS)	CU NIPDAU	Level-1-250C-UNLIM
SN74LVT16501DGGR	NRND	TSSOP	DGG	56	2000	Pb-Free (RoHS)	CU NIPDAU	Level-1-250C-UNLIM
SN74LVT16501DL	NRND	SSOP	DL	56	20	Green (RoHS & no Sb/Br)	CU NIPDAU	Level-1-260C-UNLIM
SN74LVT16501DLG4	OBSOLETE	SSOP	DL	56		TBD	Call TI	Call TI
SN74LVT16501DLR	NRND	SSOP	DL	56	1000	Green (RoHS & no Sb/Br)	CU NIPDAU	Level-1-260C-UNLIM
SN74LVT16501DLRG4	OBSOLETE	SSOP	DL	56		TBD	Call TI	Call TI

⁽¹⁾ The marketing status values are defined as follows:

ACTIVE: Product device recommended for new designs.

LIFEBUY: TI has announced that the device will be discontinued, and a lifetime-buy period is in effect.

NRND: Not recommended for new designs. Device is in production to support existing customers, but TI does not recommend using this part in a new design.

PREVIEW: Device has been announced but is not in production. Samples may or may not be available.

OBSOLETE: TI has discontinued the production of the device.

⁽²⁾ Eco Plan - The planned eco-friendly classification: Pb-Free (RoHS), Pb-Free (RoHS Exempt), or Green (RoHS & no Sb/Br) - please check <http://www.ti.com/productcontent> for the latest availability information and additional product content details.

TBD: The Pb-Free/Green conversion plan has not been defined.

Pb-Free (RoHS): TI's terms "Lead-Free" or "Pb-Free" mean semiconductor products that are compatible with the current RoHS requirements for all 6 substances, including the requirement that lead not exceed 0.1% by weight in homogeneous materials. Where designed to be soldered at high temperatures, TI Pb-Free products are suitable for use in specified lead-free processes.

Pb-Free (RoHS Exempt): This component has a RoHS exemption for either 1) lead-based flip-chip solder bumps used between the die and package, or 2) lead-based die adhesive used between the die and leadframe. The component is otherwise considered Pb-Free (RoHS compatible) as defined above.

Green (RoHS & no Sb/Br): TI defines "Green" to mean Pb-Free (RoHS compatible), and free of Bromine (Br) and Antimony (Sb) based flame retardants (Br or Sb do not exceed 0.1% by weight in homogeneous material)

⁽³⁾ MSL, Peak Temp. -- The Moisture Sensitivity Level rating according to the JEDEC industry standard classifications, and peak solder temperature.

Important Information and Disclaimer:The information provided on this page represents TI's knowledge and belief as of the date that it is provided. TI bases its knowledge and belief on information provided by third parties, and makes no representation or warranty as to the accuracy of such information. Efforts are underway to better integrate information from third parties. TI has taken and continues to take reasonable steps to provide representative and accurate information but may not have conducted destructive testing or chemical analysis on incoming materials and chemicals. TI and TI suppliers consider certain information to be proprietary, and thus CAS numbers and other limited information may not be available for release.

In no event shall TI's liability arising out of such information exceed the total purchase price of the TI part(s) at issue in this document sold by TI to Customer on an annual basis.

DL (R-PDSO-G**)

PLASTIC SMALL-OUTLINE PACKAGE

48 PINS SHOWN

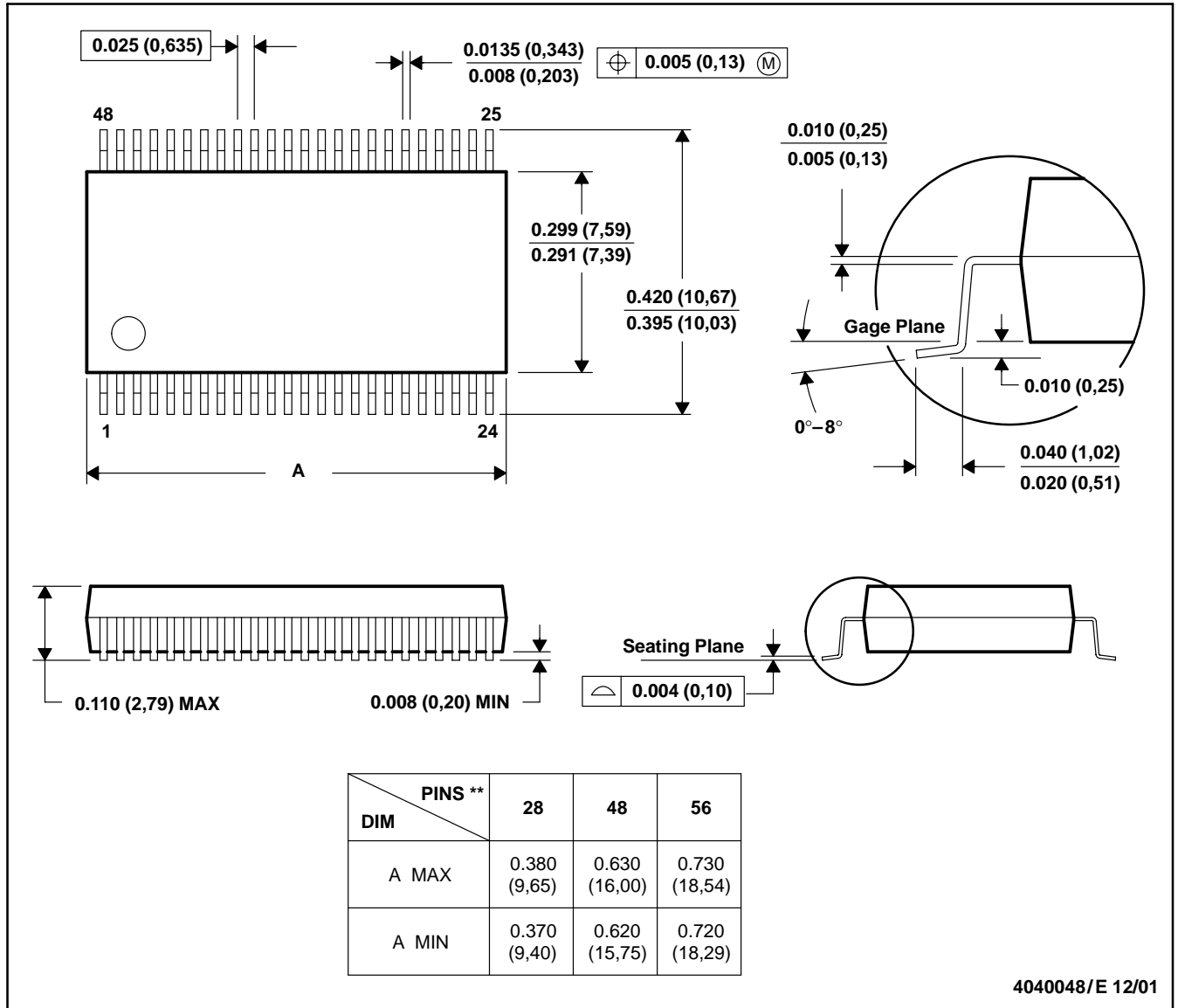

- NOTES: A. All linear dimensions are in inches (millimeters).
 B. This drawing is subject to change without notice.
 C. Body dimensions do not include mold flash or protrusion not to exceed 0.006 (0,15).
 D. Falls within JEDEC MO-118

DGG (R-PDSO-G**)

PLASTIC SMALL-OUTLINE PACKAGE

48 PINS SHOWN



- NOTES: A. All linear dimensions are in millimeters.
 B. This drawing is subject to change without notice.
 C. Body dimensions do not include mold protrusion not to exceed 0,15.
 D. Falls within JEDEC MO-153

IMPORTANT NOTICE

Texas Instruments Incorporated and its subsidiaries (TI) reserve the right to make corrections, modifications, enhancements, improvements, and other changes to its products and services at any time and to discontinue any product or service without notice. Customers should obtain the latest relevant information before placing orders and should verify that such information is current and complete. All products are sold subject to TI's terms and conditions of sale supplied at the time of order acknowledgment.

TI warrants performance of its hardware products to the specifications applicable at the time of sale in accordance with TI's standard warranty. Testing and other quality control techniques are used to the extent TI deems necessary to support this warranty. Except where mandated by government requirements, testing of all parameters of each product is not necessarily performed.

TI assumes no liability for applications assistance or customer product design. Customers are responsible for their products and applications using TI components. To minimize the risks associated with customer products and applications, customers should provide adequate design and operating safeguards.

TI does not warrant or represent that any license, either express or implied, is granted under any TI patent right, copyright, mask work right, or other TI intellectual property right relating to any combination, machine, or process in which TI products or services are used. Information published by TI regarding third-party products or services does not constitute a license from TI to use such products or services or a warranty or endorsement thereof. Use of such information may require a license from a third party under the patents or other intellectual property of the third party, or a license from TI under the patents or other intellectual property of TI.

Reproduction of information in TI data books or data sheets is permissible only if reproduction is without alteration and is accompanied by all associated warranties, conditions, limitations, and notices. Reproduction of this information with alteration is an unfair and deceptive business practice. TI is not responsible or liable for such altered documentation.

Resale of TI products or services with statements different from or beyond the parameters stated by TI for that product or service voids all express and any implied warranties for the associated TI product or service and is an unfair and deceptive business practice. TI is not responsible or liable for any such statements.

Following are URLs where you can obtain information on other Texas Instruments products and application solutions:

Products		Applications	
Amplifiers	amplifier.ti.com	Audio	www.ti.com/audio
Data Converters	dataconverter.ti.com	Automotive	www.ti.com/automotive
DSP	dsp.ti.com	Broadband	www.ti.com/broadband
Interface	interface.ti.com	Digital Control	www.ti.com/digitalcontrol
Logic	logic.ti.com	Military	www.ti.com/military
Power Mgmt	power.ti.com	Optical Networking	www.ti.com/opticalnetwork
Microcontrollers	microcontroller.ti.com	Security	www.ti.com/security
		Telephony	www.ti.com/telephony
		Video & Imaging	www.ti.com/video
		Wireless	www.ti.com/wireless

Mailing Address: Texas Instruments
Post Office Box 655303 Dallas, Texas 75265

Copyright © 2006, Texas Instruments Incorporated