

SN54LV595A, SN74LV595A 8-BIT SHIFT REGISTERS WITH 3-STATE OUTPUT REGISTERS

SCLS414L – APRIL 1998 – REVISED FEBRUARY 2004

- 2-V to 5.5-V V_{CC} Operation
- Max t_{pd} of 7.1 ns at 5 V
- Typical V_{OLP} (Output Ground Bounce) <0.8 V at $V_{CC} = 3.3$ V, $T_A = 25^\circ\text{C}$
- Typical V_{OHV} (Output V_{OH} Undershoot) >2.3 V at $V_{CC} = 3.3$ V, $T_A = 25^\circ\text{C}$
- Support Mixed-Mode Voltage Operation on All Ports
- 8-Bit Serial-In, Parallel-Out Shift
- I_{off} Supports Partial-Power-Down Mode Operation
- Shift Register Has Direct Clear
- Latch-Up Performance Exceeds 250 mA Per JESD 17
- ESD Protection Exceeds JESD 22
 - 2000-V Human-Body Model (A114-A)
 - 200-V Machine Model (A115-A)
 - 1000-V Charged-Device Model (C101)

SN54LV595A ... J OR W PACKAGE
SN74LV595A ... D, DB, NS,
OR PW PACKAGE
(TOP VIEW)

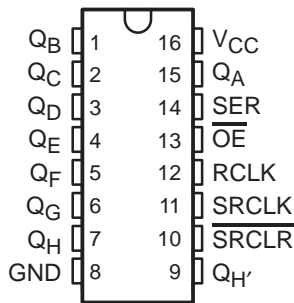

SN74LV595A ... RGY PACKAGE
(TOP VIEW)

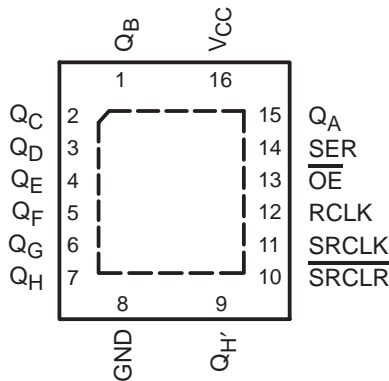

SN54LV595A ... FK PACKAGE
(TOP VIEW)

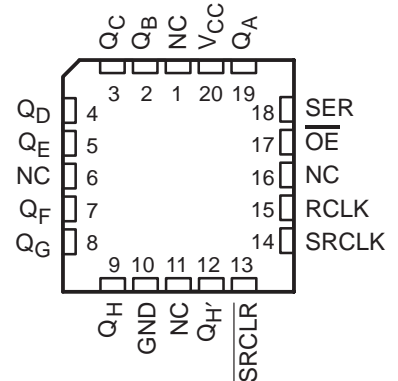

NC – No internal connection

description/ordering information

The 'LV595A devices are 8-bit shift registers designed for 2-V to 5.5-V V_{CC} operation.

ORDERING INFORMATION

T_A	PACKAGE†		ORDERABLE PART NUMBER	TOP-SIDE MARKING	
–40°C to 85°C	QFN – RGY	Reel of 1000	SN74LV595ARGYR	LV595A	
	SOIC – D	Tube of 40	SN74LV595AD	LV595A	
		Reel of 2500	SN74LV595ADR		
	–55°C to 125°C	SOP – NS	Reel of 2000	SN74LV595ANSR	74LV595A
		SSOP – DB	Reel of 2000	SN74LV595ADBR	LV595A
		TSSOP – PW	Tube of 90	SN74LV595APW	LV595A
Reel of 2000			SN74LV595APWR		
Reel of 250	SN74LV595APWT				
–55°C to 125°C	CDIP – J	Tube of 25	SNJ54LV595AJ	SNJ54LV595AJ	
	CFP – W	Tube of 150	SNJ54LV595AW	SNJ54LV595AW	
	LCCC – FK	Tube of 55	SNJ54LV595AFK	SNJ54LV595AFK	

† Package drawings, standard packing quantities, thermal data, symbolization, and PCB design guidelines are available at www.ti.com/sc/package.



Please be aware that an important notice concerning availability, standard warranty, and use in critical applications of Texas Instruments semiconductor products and disclaimers thereto appears at the end of this data sheet.

UNLESS OTHERWISE NOTED this document contains PRODUCTION DATA information current as of publication date. Products conform to specifications per the terms of Texas Instruments standard warranty. Production processing does not necessarily include testing of all parameters.

 **TEXAS
INSTRUMENTS**

POST OFFICE BOX 655303 • DALLAS, TEXAS 75265

Copyright © 2004, Texas Instruments Incorporated

SN54LV595A, SN74LV595A
8-BIT SHIFT REGISTERS
WITH 3-STATE OUTPUT REGISTERS

SCLS414L – APRIL 1998 – REVISED FEBRUARY 2004

description/ordering information (continued)

These devices contain an 8-bit serial-in, parallel-out shift register that feeds an 8-bit D-type storage register. The storage register has parallel 3-state outputs. Separate clocks are provided for both the shift and storage register. The shift register has a direct overriding clear ($\overline{\text{SRCLR}}$) input, serial (SER) input, and a serial output for cascading. When the output-enable ($\overline{\text{OE}}$) input is high, all outputs except Q_H are in the high-impedance state.

Both the shift register clock (SRCLK) and storage register clock (RCLK) are positive-edge triggered. If both clocks are connected together, the shift register always is one clock pulse ahead of the storage register.

To ensure the high-impedance state during power up or power down, $\overline{\text{OE}}$ should be tied to V_{CC} through a pullup resistor; the minimum value of the resistor is determined by the current-sinking capability of the driver.

These devices are fully specified for partial-power-down applications using I_{off} . The I_{off} circuitry disables the outputs, preventing damaging current backflow through the devices when they are powered down.

FUNCTION TABLE

INPUTS					FUNCTION
SER	SRCLK	$\overline{\text{SRCLR}}$	RCLK	$\overline{\text{OE}}$	
X	X	X	X	H	Outputs Q_A – Q_H are disabled.
X	X	X	X	L	Outputs Q_A – Q_H are enabled.
X	X	L	X	X	Shift register is cleared.
L	↑	H	X	X	First stage of the shift register goes low. Other stages store the data of previous stage, respectively.
H	↑	H	X	X	First stage of the shift register goes high. Other stages store the data of previous stage, respectively.
X	X	X	↑	X	Shift-register data is stored in the storage register.



SN54LV595A, SN74LV595A
8-BIT SHIFT REGISTERS
WITH 3-STATE OUTPUT REGISTERS

SCLS414L – APRIL 1998 – REVISED FEBRUARY 2004

logic diagram (positive logic)

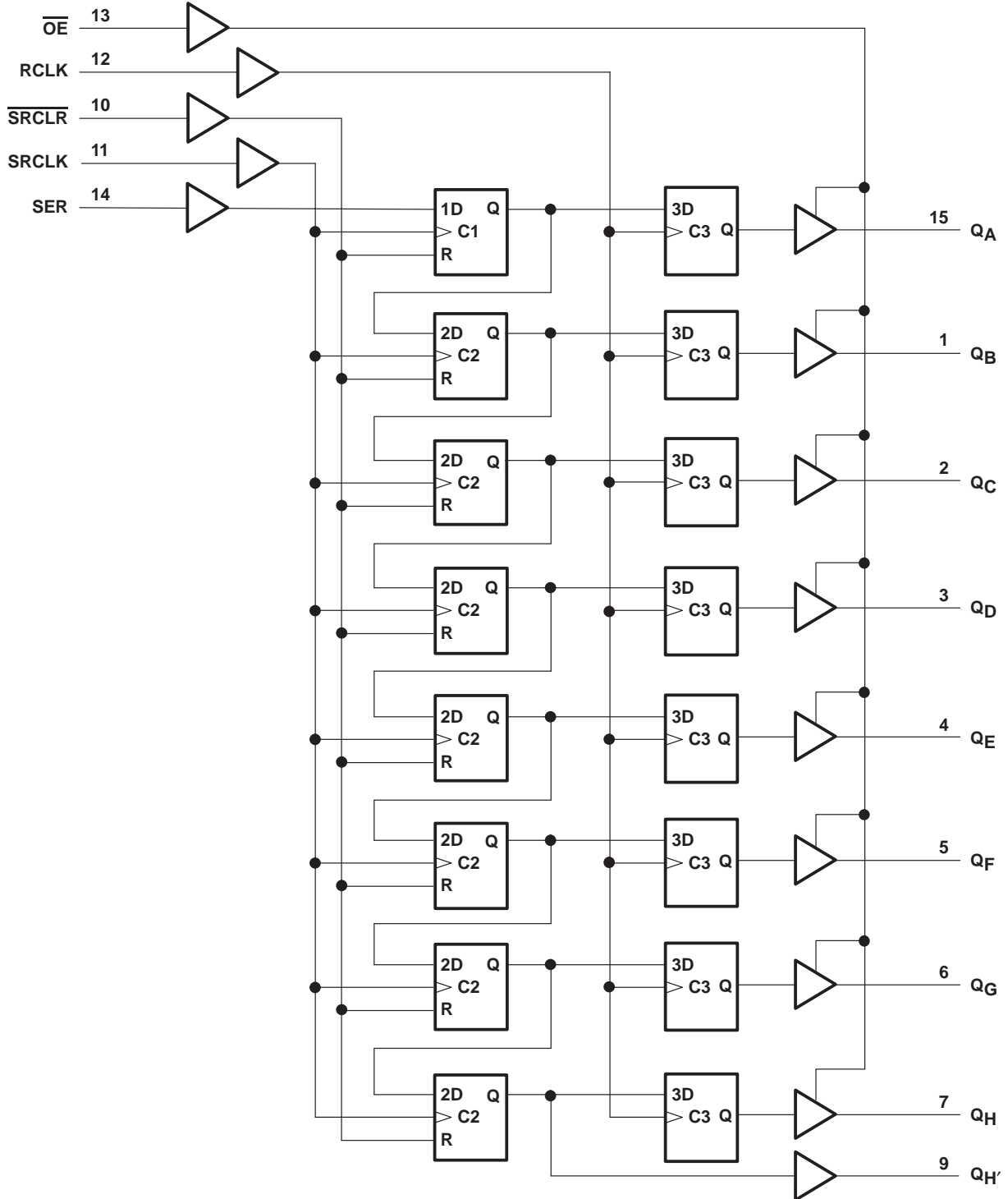

Pin numbers shown are for the D, DB, J, NS, PW, RGY, and W packages.

SN54LV595A, SN74LV595A
8-BIT SHIFT REGISTERS
WITH 3-STATE OUTPUT REGISTERS

SCLS414L – APRIL 1998 – REVISED FEBRUARY 2004

timing diagram

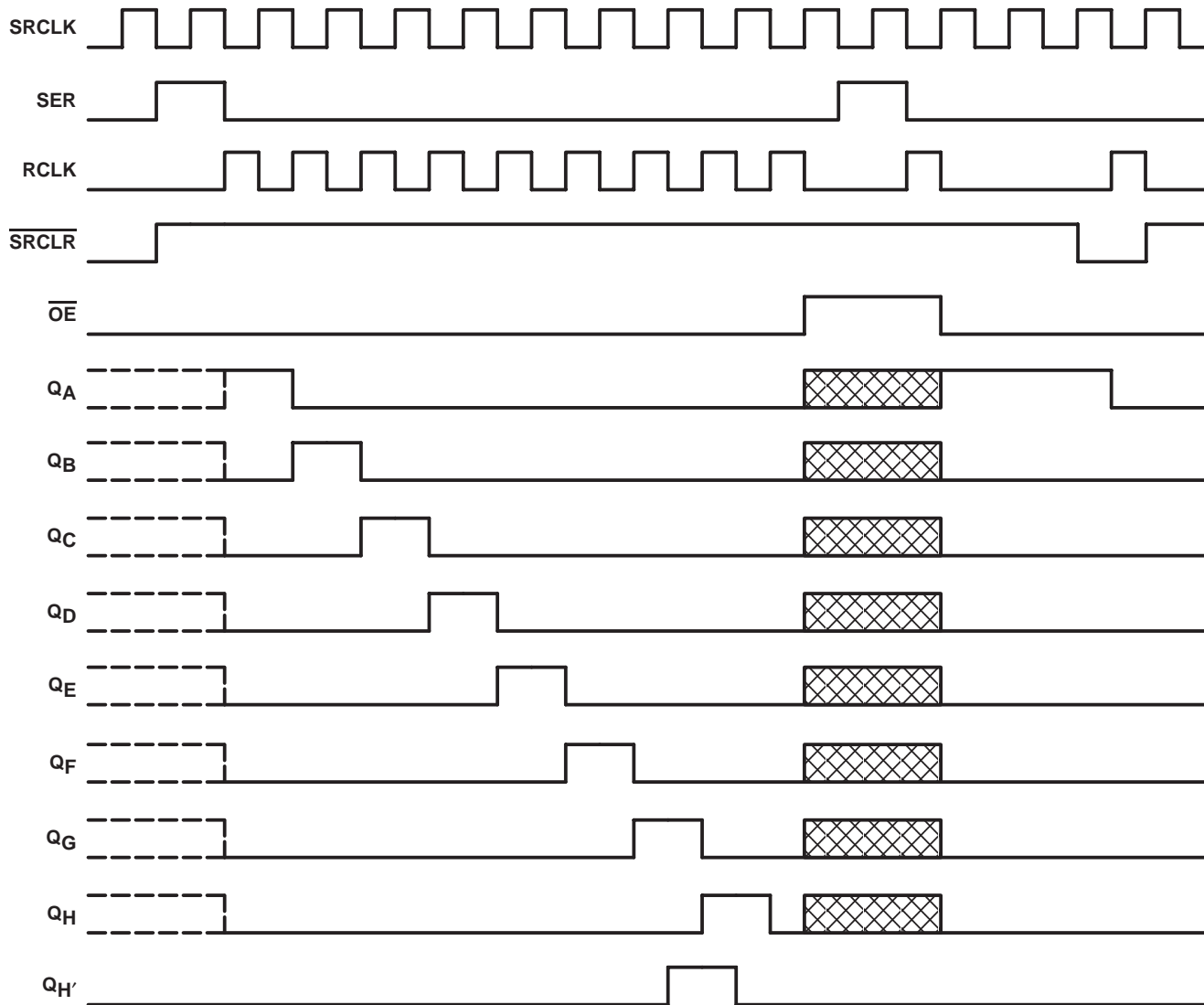

NOTE:  implies that the output is in 3-State mode.

SN54LV595A, SN74LV595A
8-BIT SHIFT REGISTERS
WITH 3-STATE OUTPUT REGISTERS

SCLS414L – APRIL 1998 – REVISED FEBRUARY 2004

absolute maximum ratings over operating free-air temperature range (unless otherwise noted)†

Supply voltage range, V_{CC}	-0.5 V to 7 V
Input voltage range, V_I (see Note 1)	-0.5 V to 7 V
Voltage range applied to any output in the high-impedance or power-off state, V_O (see Note 1)	-0.5 V to 7 V
Output voltage range applied in the high or low state, V_O (see Notes 1 and 2)	-0.5 V to $V_{CC} + 0.5$ V
Input clamp current, I_{IK} ($V_I < 0$)	-20 mA
Output clamp current, I_{OK} ($V_O < 0$ or $V_O > V_{CC}$)	± 50 mA
Continuous output current, I_O ($V_O = 0$ to V_{CC})	± 35 mA
Continuous current through V_{CC} or GND	± 70 mA
Package thermal impedance, θ_{JA} (see Note 3): D package	73°C/W
(see Note 3): DB package	82°C/W
(see Note 3): NS package	64°C/W
(see Note 3): PW package	108°C/W
(see Note 4): RGY package	39°C/W
Storage temperature range, T_{stg}	-65°C to 150°C

† Stresses beyond those listed under “absolute maximum ratings” may cause permanent damage to the device. These are stress ratings only, and functional operation of the device at these or any other conditions beyond those indicated under “recommended operating conditions” is not implied. Exposure to absolute-maximum-rated conditions for extended periods may affect device reliability.

- NOTES: 1. The input and output voltage ratings may be exceeded if the input and output current ratings are observed.
2. This value is limited to 5.5 V maximum.
3. The package thermal impedance is calculated in accordance with JESD 51-7.
4. The package thermal impedance is calculated in accordance with JESD 51-5.



SN54LV595A, SN74LV595A 8-BIT SHIFT REGISTERS WITH 3-STATE OUTPUT REGISTERS

SCLS414L – APRIL 1998 – REVISED FEBRUARY 2004

recommended operating conditions (see Note 5)

		SN54LV595A		SN74LV595A		UNIT	
		MIN	MAX	MIN	MAX		
V_{CC}	Supply voltage	2	5.5	2	5.5	V	
V_{IH}	High-level input voltage	$V_{CC} = 2\text{ V}$	1.5	1.5		V	
		$V_{CC} = 2.3\text{ V to }2.7\text{ V}$	$V_{CC} \times 0.7$	$V_{CC} \times 0.7$			
		$V_{CC} = 3\text{ V to }3.6\text{ V}$	$V_{CC} \times 0.7$	$V_{CC} \times 0.7$			
		$V_{CC} = 4.5\text{ V to }5.5\text{ V}$	$V_{CC} \times 0.7$	$V_{CC} \times 0.7$			
V_{IL}	Low-level input voltage	$V_{CC} = 2\text{ V}$	0.5	0.5		V	
		$V_{CC} = 2.3\text{ V to }2.7\text{ V}$	$V_{CC} \times 0.3$	$V_{CC} \times 0.3$			
		$V_{CC} = 3\text{ V to }3.6\text{ V}$	$V_{CC} \times 0.3$	$V_{CC} \times 0.3$			
		$V_{CC} = 4.5\text{ V to }5.5\text{ V}$	$V_{CC} \times 0.3$	$V_{CC} \times 0.3$			
V_I	Input voltage	0	5.5	0	5.5	V	
V_O	Output voltage	High or low state	0	V_{CC}	0	V_{CC}	V
		3-state	0	5.5	0	5.5	
I_{OH}	High-level output current	$V_{CC} = 2\text{ V}$		-50	-50	μA	
		$V_{CC} = 2.3\text{ V to }2.7\text{ V}$		-2	-2	mA	
		$V_{CC} = 3\text{ V to }3.6\text{ V}$		-8	-8		
		$V_{CC} = 4.5\text{ V to }5.5\text{ V}$		-16	-16		
I_{OL}	Low-level output current	$V_{CC} = 2\text{ V}$		50	50	μA	
		$V_{CC} = 2.3\text{ V to }2.7\text{ V}$		2	2	mA	
		$V_{CC} = 3\text{ V to }3.6\text{ V}$		8	8		
		$V_{CC} = 4.5\text{ V to }5.5\text{ V}$		16	16		
$\Delta t/\Delta v$	Input transition rise or fall rate	$V_{CC} = 2.3\text{ V to }2.7\text{ V}$		200	200	ns/V	
		$V_{CC} = 3\text{ V to }3.6\text{ V}$		100	100		
		$V_{CC} = 4.5\text{ V to }5.5\text{ V}$		20	20		
T_A	Operating free-air temperature	-55	125	-40	85	$^{\circ}\text{C}$	

NOTE 5: All unused inputs of the device must be held at V_{CC} or GND to ensure proper device operation. Refer to the TI application report, *Implications of Slow or Floating CMOS Inputs*, literature number SCBA004.

PRODUCT PREVIEW information concerns products in the formative or design phase of development. Characteristic data and other specifications are design goals. Texas Instruments reserves the right to change or discontinue these products without notice.



SN54LV595A, SN74LV595A
8-BIT SHIFT REGISTERS
WITH 3-STATE OUTPUT REGISTERS

SCLS414L – APRIL 1998 – REVISED FEBRUARY 2004

electrical characteristics over recommended operating free-air temperature range (unless otherwise noted)

PARAMETER		TEST CONDITIONS	V _{CC}	SN54LV595A			SN74LV595A			UNIT
				MIN	TYP	MAX	MIN	TYP	MAX	
V _{OH}		I _{OH} = -50 μA	2 V to 5.5 V	V _{CC} -0.1			V _{CC} -0.1			V
		I _{OH} = -2 mA	2.3 V	2			2			
	Q _{H'}	3 V	I _{OH} = -6 mA	2.48			2.48			
	Q _A -Q _H		I _{OH} = -8 mA	2.48			2.48			
	Q _{H'}	4.5 V	I _{OH} = -12 mA	3.8			3.8			
	Q _A -Q _H		I _{OH} = -16 mA	3.8			3.8			
V _{OL}		I _{OL} = 50 μA	2 V to 5.5 V				0.1			V
		I _{OL} = 2 mA	2.3 V				0.4			
	Q _{H'}	3 V	I _{OL} = 6 mA				0.44			
	Q _A -Q _H		I _{OL} = 8 mA				0.44			
	Q _{H'}	4.5 V	I _{OL} = 12 mA				0.55			
	Q _A -Q _H		I _{OL} = 16 mA				0.55			
I _I		V _I = 5.5 V or GND	0 to 5.5 V				±1			μA
I _{OZ}		V _O = V _{CC} or GND, Q _A -Q _H	5.5 V				±5			μA
I _{CC}		V _I = V _{CC} or GND, I _O = 0	5.5 V				20			μA
I _{off}		V _I or V _O = 0 to 5.5 V	0				5			μA
C _i		V _I = V _{CC} or GND	3.3 V	3.5			3.5			pF

timing requirements over recommended operating free-air temperature range, V_{CC} = 2.5 V ± 0.2 V (unless otherwise noted) (see Figure 1)

			T _A = 25°C		SN54LV595A		SN74LV595A		UNIT
			MIN	MAX	MIN	MAX	MIN	MAX	
t _w	Pulse duration	SRCLK high or low	7		7.5		7.5		ns
		RCLK high or low	7		7.5		7.5		
		SRCLR low	6		6.5		6.5		
t _{su}	Setup time	SER before SRCLK↑	5.5		5.5		5.5		ns
		SRCLK↑ before RCLK↑†	8		9		9		
		SRCLR low before RCLK↑	8.5		9.5		9.5		
		SRCLR high (inactive) before SRCLK↑	4		4		4		
t _h	Hold time	SER after SRCLK↑	1.5		1.5		1.5		ns

† This setup time allows the storage register to receive stable data from the shift register. The clocks can be tied together, in which case the shift register is one clock pulse ahead of the storage register.

SN54LV595A, SN74LV595A 8-BIT SHIFT REGISTERS WITH 3-STATE OUTPUT REGISTERS

SCLS414L – APRIL 1998 – REVISED FEBRUARY 2004

timing requirements over recommended operating free-air temperature range, $V_{CC} = 3.3\text{ V} \pm 0.3\text{ V}$ (unless otherwise noted) (see Figure 1)

		$T_A = 25^\circ\text{C}$		SN54LV595A		SN74LV595A		UNIT
		MIN	MAX	MIN	MAX	MIN	MAX	
t_w	Pulse duration	SRCLK high or low		5.5	5.5	5.5	5.5	ns
		RCLK high or low		5.5	5.5	5.5	5.5	
		$\overline{\text{SRCLR}}$ low		5	5	5	5	
t_{su}	Setup time	SER before SRCLK \uparrow		3.5	3.5	3.5	3.5	ns
		SRCLK \uparrow before RCLK $\uparrow\uparrow$		8	8.5	8.5	8.5	
		$\overline{\text{SRCLR}}$ low before RCLK \uparrow		8	9	9	9	
		$\overline{\text{SRCLR}}$ high (inactive) before SRCLK \uparrow		3	3	3	3	
t_h	Hold time	SER after SRCLK \uparrow		1.5	1.5	1.5	1.5	ns

† This setup time allows the storage register to receive stable data from the shift register. The clocks can be tied together, in which case the shift register is one clock pulse ahead of the storage register.

timing requirements over recommended operating free-air temperature range, $V_{CC} = 5\text{ V} \pm 0.5\text{ V}$ (unless otherwise noted) (see Figure 1)

		$T_A = 25^\circ\text{C}$		SN54LV595A		SN74LV595A		UNIT
		MIN	MAX	MIN	MAX	MIN	MAX	
t_w	Pulse duration	SRCLK high or low		5	5	5	5	ns
		RCLK high or low		5	5	5	5	
		$\overline{\text{SRCLR}}$ low		5.2	5.2	5.2	5.2	
t_{su}	Setup time	SER before SRCLK \uparrow		3	3	3	3	ns
		SRCLK \uparrow before RCLK $\uparrow\uparrow$		5	5	5	5	
		$\overline{\text{SRCLR}}$ low before RCLK \uparrow		5	5	5	5	
		$\overline{\text{SRCLR}}$ high (inactive) before SRCLK \uparrow		2.5	2.5	2.5	2.5	
t_h	Hold time	SER after SRCLK \uparrow		2	2	2	2	ns

† This setup time allows the storage register to receive stable data from the shift register. The clocks can be tied together, in which case the shift register is one clock pulse ahead of the storage register.

SN54LV595A, SN74LV595A 8-BIT SHIFT REGISTERS WITH 3-STATE OUTPUT REGISTERS

SCLS414L – APRIL 1998 – REVISED FEBRUARY 2004

switching characteristics over recommended operating free-air temperature range, $V_{CC} = 2.5\text{ V} \pm 0.2\text{ V}$ (unless otherwise noted) (see Figure 1)

PARAMETER	FROM (INPUT)	TO (OUTPUT)	LOAD CAPACITANCE	$T_A = 25^\circ\text{C}$			SN54LV595A		SN74LV595A		UNIT
				MIN	TYP	MAX	MIN	MAX	MIN	MAX	
f_{max}			$C_L = 15\text{ pF}$	65*	80*		45*		45		MHz
			$C_L = 50\text{ pF}$	60	70		40		40		
t_{PLH}	RCLK	Q_A-Q_H	$C_L = 15\text{ pF}$		8.4*	14.2*	1*	15.8*	1	15.8	ns
t_{PHL}					8.4*	14.2*	1*	15.8*	1	15.8	
t_{PLH}	SRCLK	$Q_{H'}$			9.4*	19.6*	1*	22.2*	1	22.2	
t_{PHL}					9.4*	19.6*	1*	22.2*	1	22.2	
t_{PHL}	$\overline{\text{SRCLR}}$	$Q_{H'}$			8.7*	14.6*	1*	16.3*	1	16.3	
t_{PZH}	$\overline{\text{OE}}$	Q_A-Q_H			8.2*	13.9*	1*	15*	1	15	
t_{PZL}					10.9*	18.1*	1*	20.3*	1	20.3	
t_{PHZ}	$\overline{\text{OE}}$	Q_A-Q_H			8.3*	13.7*	1*	15.6*	1	15.6	
t_{PLZ}					9.2*	15.2*	1*	16.7*	1	16.7	
t_{PLH}	RCLK	Q_A-Q_H		$C_L = 50\text{ pF}$		11.2	17.2	1	19.3	1	
t_{PHL}					11.2	17.2	1	19.3	1	19.3	
t_{PLH}	SRCLK	$Q_{H'}$			13.1	22.5	1	25.5	1	25.5	
t_{PHL}					13.1	22.5	1	25.5	1	25.5	
t_{PHL}	$\overline{\text{SRCLR}}$	$Q_{H'}$			12.4	18.8	1	21.1	1	21.1	
t_{PZH}	$\overline{\text{OE}}$	Q_A-Q_H			10.8	17	1	18.3	1	18.3	
t_{PZL}					13.4	21	1	23	1	23	
t_{PHZ}	$\overline{\text{OE}}$	Q_A-Q_H			12.2	18.3	1	19.5	1	19.5	
t_{PLZ}					14	20.9	1	22.6	1	22.6	

* On products compliant to MIL-PRF-38535, this parameter is not production tested.

PRODUCT PREVIEW information concerns products in the formative or design phase of development. Characteristic data and other specifications are design goals. Texas Instruments reserves the right to change or discontinue these products without notice.



POST OFFICE BOX 655303 • DALLAS, TEXAS 75265

SN54LV595A, SN74LV595A 8-BIT SHIFT REGISTERS WITH 3-STATE OUTPUT REGISTERS

SCLS414L – APRIL 1998 – REVISED FEBRUARY 2004

switching characteristics over recommended operating free-air temperature range, $V_{CC} = 3.3 V \pm 0.3 V$ (unless otherwise noted) (see Figure 1)

PARAMETER	FROM (INPUT)	TO (OUTPUT)	LOAD CAPACITANCE	$T_A = 25^\circ C$			SN54LV595A		SN74LV595A		UNIT
				MIN	TYP	MAX	MIN	MAX	MIN	MAX	
f_{max}			$C_L = 15 \text{ pF}$	80*	120*		70*		70		MHz
			$C_L = 50 \text{ pF}$	55	105		50		50		
t_{PLH}	RCLK	Q_A-Q_H	$C_L = 15 \text{ pF}$		6*	11.9*	1*	13.5*	1	13.5	ns
t_{PHL}					6*	11.9*	1*	13.5*	1	13.5	
t_{PLH}	SRCLK	Q_H'			6.6*	13*	1*	15*	1	15	
t_{PHL}					6.6*	13*	1*	15*	1	15	
t_{PHL}	$\overline{\text{SRCLR}}$	Q_H'			6.2*	12.8*	1*	13.7*	1	13.7	
t_{PZH}	$\overline{\text{OE}}$	Q_A-Q_H			6*	11.5*	1*	13.5*	1	13.5	
t_{PZL}					7.8*	11.5*	1*	13.5*	1	13.5	
t_{PHZ}	$\overline{\text{OE}}$	Q_A-Q_H			6.1*	14.7*	1*	15.2*	1	15.2	
t_{PLZ}					6.3*	14.7*	1*	15.2*	1	15.2	
t_{PLH}	RCLK	Q_A-Q_H		$C_L = 50 \text{ pF}$		7.9	15.4	1	17	1	
t_{PHL}					7.9	15.4	1	17	1	17	
t_{PLH}	SRCLK	Q_H'			9.2	16.5	1	18.5	1	18.5	
t_{PHL}					9.2	16.5	1	18.5	1	18.5	
t_{PHL}	$\overline{\text{SRCLR}}$	Q_H'			9	16.3	1	17.2	1	17.2	
t_{PZH}	$\overline{\text{OE}}$	Q_A-Q_H			7.8	15	1	17	1	17	
t_{PZL}					9.6	15	1	17	1	17	
t_{PHZ}	$\overline{\text{OE}}$	Q_A-Q_H			8.1	15.7	1	16.2	1	16.2	
t_{PLZ}					9.3	15.7	1	16.2	1	16.2	

* On products compliant to MIL-PRF-38535, this parameter is not production tested.

PRODUCT PREVIEW information concerns products in the formative or design phase of development. Characteristic data and other specifications are design goals. Texas Instruments reserves the right to change or discontinue these products without notice.



SN54LV595A, SN74LV595A
8-BIT SHIFT REGISTERS
WITH 3-STATE OUTPUT REGISTERS

SCLS414L – APRIL 1998 – REVISED FEBRUARY 2004

switching characteristics over recommended operating free-air temperature range, $V_{CC} = 5\text{ V} \pm 0.5\text{ V}$ (unless otherwise noted) (see Figure 1)

PARAMETER	FROM (INPUT)	TO (OUTPUT)	LOAD CAPACITANCE	$T_A = 25^\circ\text{C}$			SN54LV595A		SN74LV595A		UNIT
				MIN	TYP	MAX	MIN	MAX	MIN	MAX	
f_{max}			$C_L = 15\text{ pF}$	135*	170*		115*		115		MHz
			$C_L = 50\text{ pF}$	120	140		95		95		
t_{PLH}	RCLK	Q_A-Q_H	$C_L = 15\text{ pF}$	4.3*	7.4*	1*	8.5*	1	8.5	ns	
t_{PHL}				4.3*	7.4*	1*	8.5*	1	8.5		
t_{PLH}	SRCLK	$Q_{H'}$		4.5*	8.2*	1*	9.4*	1	9.4		
t_{PHL}				4.5*	8.2*	1*	9.4*	1	9.4		
t_{PHL}	$\overline{\text{SRCLR}}$	$Q_{H'}$		4.5*	8*	1*	9.1*	1	9.1		
t_{PZH}	$\overline{\text{OE}}$	Q_A-Q_H		4.3*	8.6*	1*	10*	1	10		
t_{PZL}				5.4*	8.6*	1*	10*	1	10		
t_{PHZ}	$\overline{\text{OE}}$	Q_A-Q_H		2.4*	6*	1*	7.1*	1	7.1		
t_{PLZ}				2.7*	5.1*	1*	7.2*	1	7.2		
t_{PLH}	RCLK	Q_A-Q_H		$C_L = 50\text{ pF}$	5.6	9.4	1	10.5	1		10.5
t_{PHL}			5.6		9.4	1	10.5	1	10.5		
t_{PLH}	SRCLK	$Q_{H'}$	6.4		10.2	1	11.4	1	11.4		
t_{PHL}			6.4		10.2	1	11.4	1	11.4		
t_{PHL}	$\overline{\text{SRCLR}}$	$Q_{H'}$	6.4		10	1	11.1	1	11.1		
t_{PZH}	$\overline{\text{OE}}$	Q_A-Q_H	5.7		10.6	1	12	1	12		
t_{PZL}			6.8		10.6	1	12	1	12		
t_{PHZ}	$\overline{\text{OE}}$	Q_A-Q_H	3.5		10.3	1	11	1	11		
t_{PLZ}			3.4		10.3	1	11	1	11		

* On products compliant to MIL-PRF-38535, this parameter is not production tested.

noise characteristics, $V_{CC} = 3.3\text{ V}$, $C_L = 50\text{ pF}$, $T_A = 25^\circ\text{C}$ (see Note 6)

PARAMETER		SN74LV595A			UNIT
		MIN	TYP	MAX	
$V_{OL(P)}$	Quiet output, maximum dynamic V_{OL}		0.3		V
$V_{OL(V)}$	Quiet output, minimum dynamic V_{OL}		-0.2		V
$V_{OH(V)}$	Quiet output, minimum dynamic V_{OH}		2.8		V
$V_{IH(D)}$	High-level dynamic input voltage	2.31			V
$V_{IL(D)}$	Low-level dynamic input voltage		0.99		V

NOTE 6: Characteristics are for surface-mount packages only.

operating characteristics, $T_A = 25^\circ\text{C}$

PARAMETER		TEST CONDITIONS	V_{CC}	TYP	UNIT
			3.3 V	111	
C_{pd}	Power dissipation capacitance	$C_L = 50\text{ pF}$, $f = 10\text{ MHz}$	5 V	114	pF

PRODUCT PREVIEW information concerns products in the formative or design phase of development. Characteristic data and other specifications are design goals. Texas Instruments reserves the right to change or discontinue these products without notice.



POST OFFICE BOX 655303 • DALLAS, TEXAS 75265

SN54LV595A, SN74LV595A 8-BIT SHIFT REGISTERS WITH 3-STATE OUTPUT REGISTERS

SCLS414L – APRIL 1998 – REVISED FEBRUARY 2004

PARAMETER MEASUREMENT INFORMATION

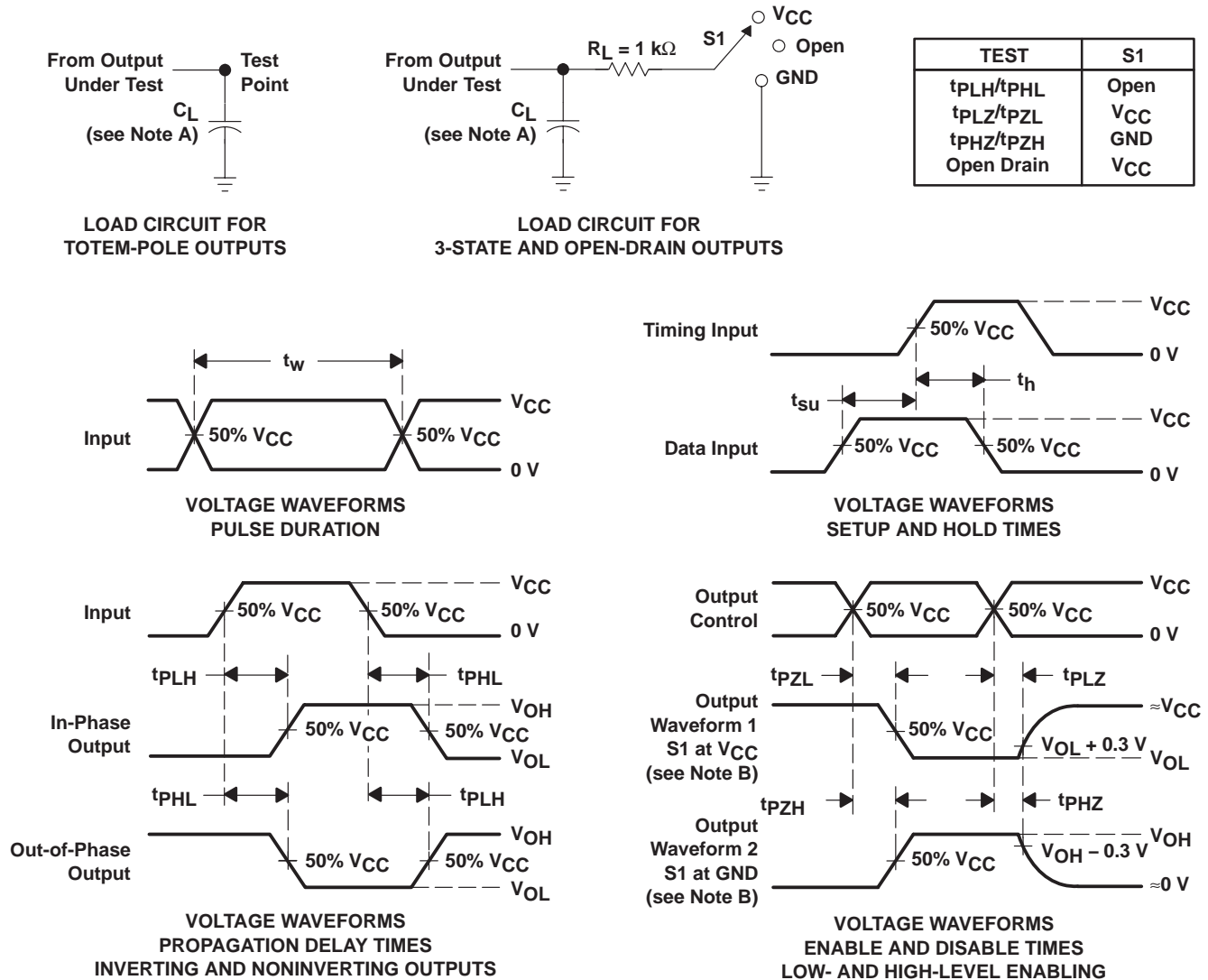

- NOTES:
- A. C_L includes probe and jig capacitance.
 - B. Waveform 1 is for an output with internal conditions such that the output is low, except when disabled by the output control. Waveform 2 is for an output with internal conditions such that the output is high, except when disabled by the output control.
 - C. All input pulses are supplied by generators having the following characteristics: PRR $\leq 1\text{ MHz}$, $Z_O = 50\ \Omega$, $t_r \leq 3\text{ ns}$, $t_f \leq 3\text{ ns}$.
 - D. The outputs are measured one at a time, with one input transition per measurement.
 - E. t_{PLZ} and t_{PHZ} are the same as t_{dis} .
 - F. t_{PZL} and t_{PZH} are the same as t_{en} .
 - G. t_{PHL} and t_{PLH} are the same as t_{pd} .
 - H. All parameters and waveforms are not applicable to all devices.

Figure 1. Load Circuit and Voltage Waveforms

D (R-PDSO-G16)

PLASTIC SMALL-OUTLINE PACKAGE

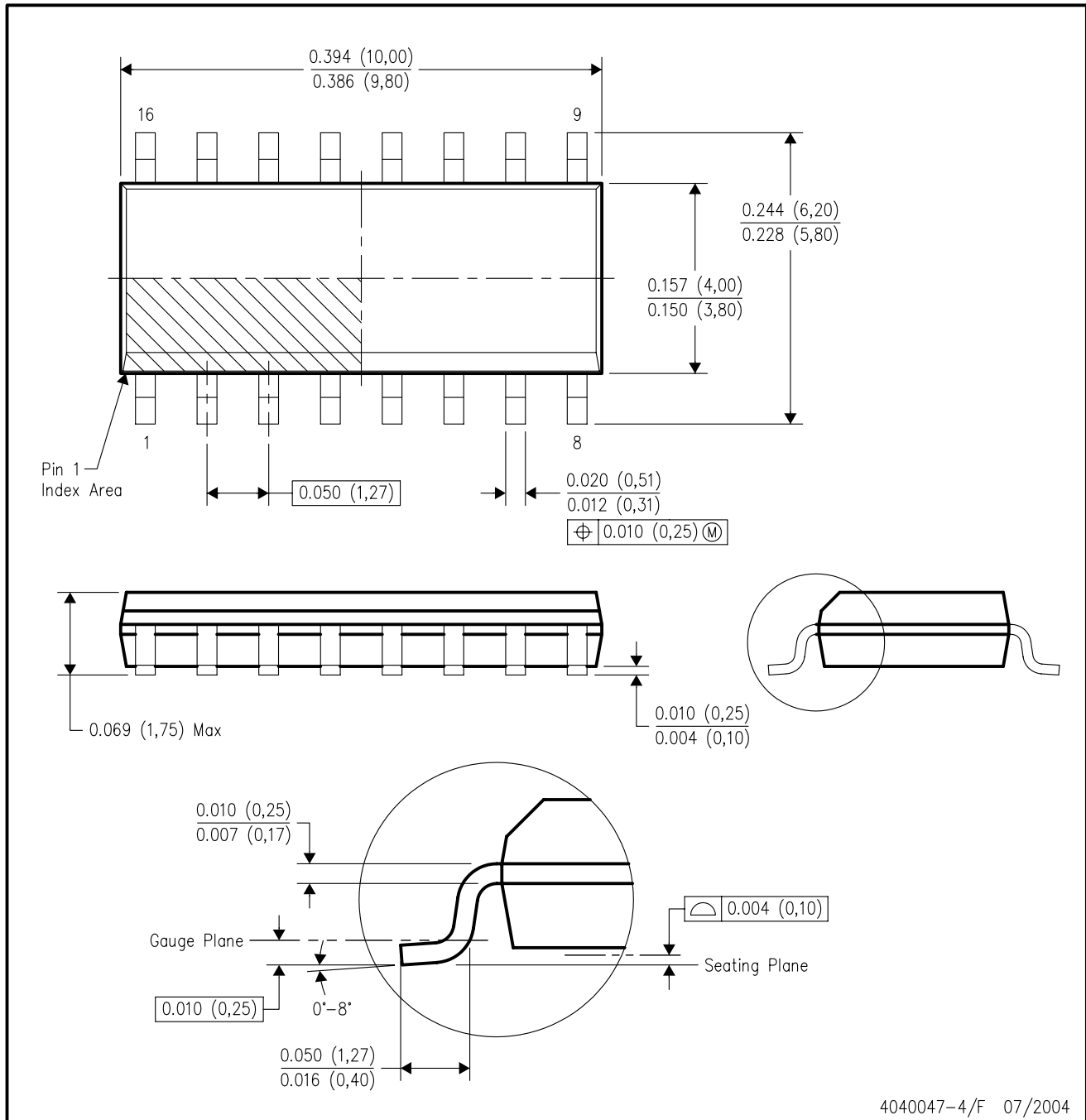

- NOTES:
- A. All linear dimensions are in inches (millimeters).
 - B. This drawing is subject to change without notice.
 - C. Body dimensions do not include mold flash or protrusion not to exceed 0.006 (0,15).
 - D. Falls within JEDEC MS-012 variation AC.

RGY (R-PQFP-N16)

PLASTIC QUAD FLATPACK

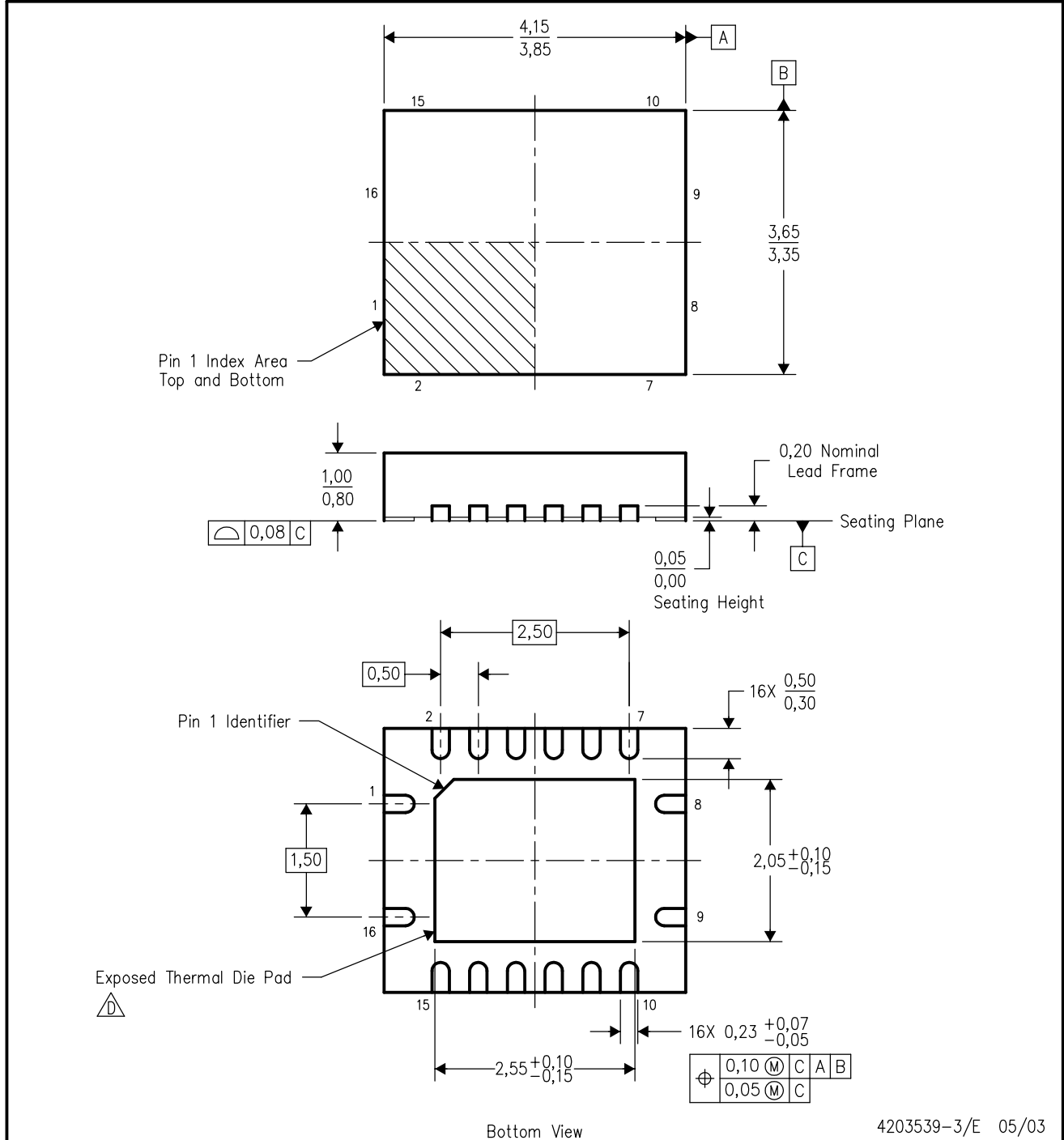

- NOTES:
- A. All linear dimensions are in millimeters.
 - B. This drawing is subject to change without notice.
 - C. QFN (Quad Flatpack No-Lead) package configuration.
 - The package thermal performance may be enhanced by bonding the thermal die pad to an external thermal plane. This pad is electrically and thermally connected to the backside of the die and possibly selected ground leads.
 - E. Package complies to JEDEC MO-241 variation BB.

MECHANICAL DATA

NS (R-PDSO-G**)

PLASTIC SMALL-OUTLINE PACKAGE

14-PINS SHOWN



- NOTES:
- A. All linear dimensions are in millimeters.
 - B. This drawing is subject to change without notice.
 - C. Body dimensions do not include mold flash or protrusion, not to exceed 0,15.

DB (R-PDSO-G**)

PLASTIC SMALL-OUTLINE

28 PINS SHOWN



- NOTES: A. All linear dimensions are in millimeters.
 B. This drawing is subject to change without notice.
 C. Body dimensions do not include mold flash or protrusion not to exceed 0,15.
 D. Falls within JEDEC MO-150

PW (R-PDSO-G**)

PLASTIC SMALL-OUTLINE PACKAGE

14 PINS SHOWN



4040064/F 01/97

- NOTES: A. All linear dimensions are in millimeters.
 B. This drawing is subject to change without notice.
 C. Body dimensions do not include mold flash or protrusion not to exceed 0,15.
 D. Falls within JEDEC MO-153

IMPORTANT NOTICE

Texas Instruments Incorporated and its subsidiaries (TI) reserve the right to make corrections, modifications, enhancements, improvements, and other changes to its products and services at any time and to discontinue any product or service without notice. Customers should obtain the latest relevant information before placing orders and should verify that such information is current and complete. All products are sold subject to TI's terms and conditions of sale supplied at the time of order acknowledgment.

TI warrants performance of its hardware products to the specifications applicable at the time of sale in accordance with TI's standard warranty. Testing and other quality control techniques are used to the extent TI deems necessary to support this warranty. Except where mandated by government requirements, testing of all parameters of each product is not necessarily performed.

TI assumes no liability for applications assistance or customer product design. Customers are responsible for their products and applications using TI components. To minimize the risks associated with customer products and applications, customers should provide adequate design and operating safeguards.

TI does not warrant or represent that any license, either express or implied, is granted under any TI patent right, copyright, mask work right, or other TI intellectual property right relating to any combination, machine, or process in which TI products or services are used. Information published by TI regarding third-party products or services does not constitute a license from TI to use such products or services or a warranty or endorsement thereof. Use of such information may require a license from a third party under the patents or other intellectual property of the third party, or a license from TI under the patents or other intellectual property of TI.

Reproduction of information in TI data books or data sheets is permissible only if reproduction is without alteration and is accompanied by all associated warranties, conditions, limitations, and notices. Reproduction of this information with alteration is an unfair and deceptive business practice. TI is not responsible or liable for such altered documentation.

Resale of TI products or services with statements different from or beyond the parameters stated by TI for that product or service voids all express and any implied warranties for the associated TI product or service and is an unfair and deceptive business practice. TI is not responsible or liable for any such statements.

Following are URLs where you can obtain information on other Texas Instruments products and application solutions:

Products		Applications	
Amplifiers	amplifier.ti.com	Audio	www.ti.com/audio
Data Converters	dataconverter.ti.com	Automotive	www.ti.com/automotive
DSP	dsp.ti.com	Broadband	www.ti.com/broadband
Interface	interface.ti.com	Digital Control	www.ti.com/digitalcontrol
Logic	logic.ti.com	Military	www.ti.com/military
Power Mgmt	power.ti.com	Optical Networking	www.ti.com/opticalnetwork
Microcontrollers	microcontroller.ti.com	Security	www.ti.com/security
		Telephony	www.ti.com/telephony
		Video & Imaging	www.ti.com/video
		Wireless	www.ti.com/wireless

Mailing Address: Texas Instruments
Post Office Box 655303 Dallas, Texas 75265

Copyright © 2004, Texas Instruments Incorporated