

# SN54LV4066A, SN74LV4066A QUADRUPLE BILATERAL ANALOG SWITCHES

SCLS4271 – APRIL 1999 – REVISED APRIL 2005

- 2-V to 5.5-V  $V_{CC}$  Operation
- Support Mixed-Mode Voltage Operation on All Ports
- High On-Off Output-Voltage Ratio
- Low Crosstalk Between Switches
- Individual Switch Controls
- Extremely Low Input Current
- ESD Protection Exceeds JESD 22
  - 2000-V Human-Body Model (A114-A)
  - 200-V Machine Model (A115-A)
  - 1000-V Charged-Device Model (C101)

## description/ordering information

This quadruple silicon-gate CMOS analog switch is designed for 2-V to 5.5-V  $V_{CC}$  operation.

These switches are designed to handle both analog and digital signals. Each switch permits signals with amplitudes up to 5.5 V (peak) to be transmitted in either direction.

Each switch section has its own enable-input control (C). A high-level voltage applied to C turns on the associated switch section.

Applications include signal gating, chopping, modulation or demodulation (modem), and signal multiplexing for analog-to-digital and digital-to-analog conversion systems.

SN54LV4066A . . . J OR W PACKAGE  
SN74LV4066A . . . D, DB, DGV, N, NS, OR PW PACKAGE  
(TOP VIEW)

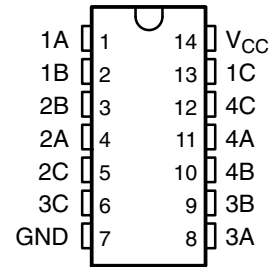

SN74LV4066A . . . RGY PACKAGE  
(TOP VIEW)

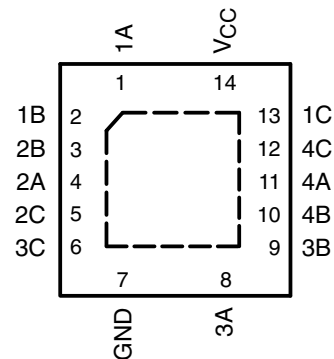

NC – No internal connection

## ORDERING INFORMATION

$T_A$	PACKAGE†		ORDERABLE PART NUMBER	TOP-SIDE MARKING
–40°C to 85°C	PDIP – N	Tube of 25	SN74LV4066AN	SN74LV4066AN
	QFN – RGY	Reel of 1000	SN74LV4066ARGYR	LW066A
	SOIC – D	Tube of 50	SN74LV4066AD	LV4066A
		Reel of 2500	SN74LV4066ADR	
	SOP – NS	Reel of 2000	SN74LV4066ANSR	74LV4066A
	SSOP – DB	Reel of 2000	SN74LV4066ADBR	LW066A
	TSSOP – PW	Tube of 90	SN74LV4066APW	LW066A
		Reel of 2000	SN74LV4066APWR	
Reel of 250		SN74LV4066APWT		
TVSOP – DGV	Reel of 2000	SN74LV4066ADGVR	LW066A	
–55°C to 125°C	CDIP – J	Tube of 25	SNJ54LV4066AJ	SNJ54LV4066AJ
	CFP – W	Tube of 150	SNJ54LV4066AW	SNJ54LV4066AW

† Package drawings, standard packing quantities, thermal data, symbolization, and PCB design guidelines are available at [www.ti.com/sc/package](http://www.ti.com/sc/package).



Please be aware that an important notice concerning availability, standard warranty, and use in critical applications of Texas Instruments semiconductor products and disclaimers thereto appears at the end of this data sheet.

UNLESS OTHERWISE NOTED this document contains PRODUCTION DATA information current as of publication date. Products conform to specifications per the terms of Texas Instruments standard warranty. Production processing does not necessarily include testing of all parameters.

 **TEXAS  
INSTRUMENTS**

POST OFFICE BOX 655303 • DALLAS, TEXAS 75265

Copyright © 2005, Texas Instruments Incorporated

# SN54LV4066A, SN74LV4066A QUADRUPLE BILATERAL ANALOG SWITCHES

SCLS4271 – APRIL 1999 – REVISED APRIL 2005

**FUNCTION TABLE**  
(each switch)

INPUT CONTROL (C)	SWITCH
L	OFF
H	ON

## logic diagram (positive logic)

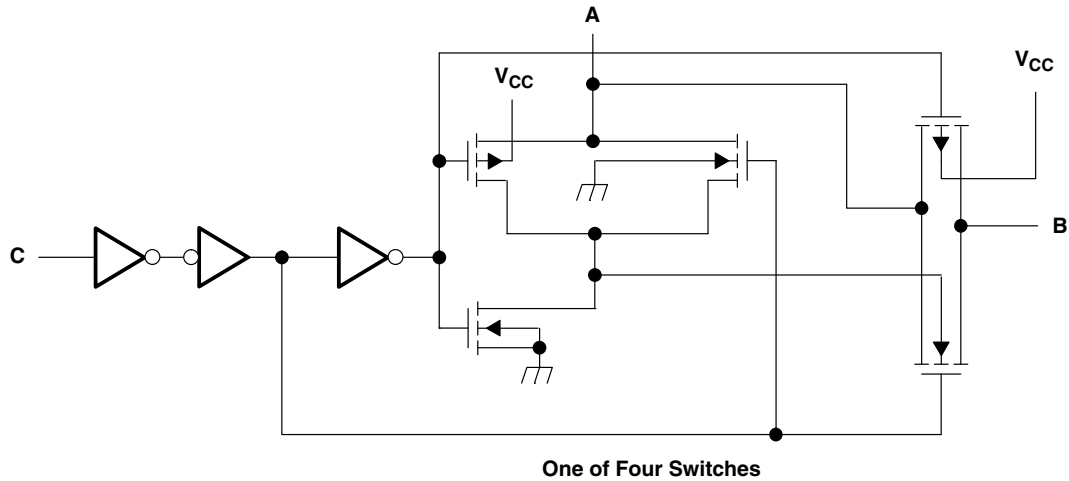

## absolute maximum ratings over operating free-air temperature range (unless otherwise noted)<sup>†</sup>

Supply voltage range, $V_{CC}$ (see Note 1)	-0.5 V to 7 V
Input voltage range, $V_I$ (see Note 1)	-0.5 V to 7 V
Switch I/O voltage range, $V_{IO}$ (see Notes 1 and 2)	-0.5 V to $V_{CC} + 0.5$ V
Control-input clamp current, $I_{IK}$ ( $V_I < 0$ )	-20 mA
I/O diode current, $I_{IOK}$ ( $V_{IO} < 0$ )	-50 mA
On-state switch current, $I_T$ ( $V_{IO} = 0$ to $V_{CC}$ )	$\pm 25$ mA
Continuous current through $V_{CC}$ or GND	$\pm 50$ mA
Package thermal impedance, $\theta_{JA}$ (see Note 3): D package	86°C/W
(see Note 3): DB package	96°C/W
(see Note 3): DGV package	127°C/W
(see Note 3): N package	80°C/W
(see Note 3): NS package	76°C/W
(see Note 3): PW package	113°C/W
(see Note 4): RGY package	47°C/W
Storage temperature range, $T_{stg}$	-65°C to 150°C

<sup>†</sup> Stresses beyond those listed under “absolute maximum ratings” may cause permanent damage to the device. These are stress ratings only, and functional operation of the device at these or any other conditions beyond those indicated under “recommended operating conditions” is not implied. Exposure to absolute-maximum-rated conditions for extended periods may affect device reliability.

- NOTES:
1. The input and output negative-voltage ratings may be exceeded if the input and output current ratings are observed.
  2. This value is limited to 5.5 V maximum.
  3. The package thermal impedance is calculated in accordance with JESD 51-7.
  4. The package thermal impedance is calculated in accordance with JESD 51-5.

# SN54LV4066A, SN74LV4066A QUADRUPLE BILATERAL ANALOG SWITCHES

SCLS4271 – APRIL 1999 – REVISED APRIL 2005

## recommended operating conditions (see Note 5)

		SN54LV4066A		SN74LV4066A		UNIT
		MIN	MAX	MIN	MAX	
$V_{CC}$	Supply voltage	2 <sup>†</sup>	5.5	2 <sup>†</sup>	5.5	V
$V_{IH}$	High-level input voltage, control inputs	$V_{CC} = 2\text{ V}$	1.5	1.5		V
		$V_{CC} = 2.3\text{ V to }2.7\text{ V}$	$V_{CC} \times 0.7$	$V_{CC} \times 0.7$		
		$V_{CC} = 3\text{ V to }3.6\text{ V}$	$V_{CC} \times 0.7$	$V_{CC} \times 0.7$		
		$V_{CC} = 4.5\text{ V to }5.5\text{ V}$	$V_{CC} \times 0.7$	$V_{CC} \times 0.7$		
$V_{IL}$	Low-level input voltage, control inputs	$V_{CC} = 2\text{ V}$		0.5	0.5	V
		$V_{CC} = 2.3\text{ V to }2.7\text{ V}$		$V_{CC} \times 0.3$	$V_{CC} \times 0.3$	
		$V_{CC} = 3\text{ V to }3.6\text{ V}$		$V_{CC} \times 0.3$	$V_{CC} \times 0.3$	
		$V_{CC} = 4.5\text{ V to }5.5\text{ V}$		$V_{CC} \times 0.3$	$V_{CC} \times 0.3$	
$V_I$	Control input voltage	0	5.5	0	5.5	V
$V_{IO}$	Input/output voltage	0	$V_{CC}$	0	$V_{CC}$	V
$\Delta t/\Delta v$	Input transition rise or fall rate	$V_{CC} = 2.3\text{ V to }2.7\text{ V}$		200	200	ns/V
		$V_{CC} = 3\text{ V to }3.6\text{ V}$		100	100	
		$V_{CC} = 4.5\text{ V to }5.5\text{ V}$		20	20	
$T_A$	Operating free-air temperature	-55	125	-40	85	°C

<sup>†</sup> With supply voltages at or near 2 V, the analog switch on-state resistance becomes very nonlinear. Only digital signals should be transmitted at these low supply voltages.

NOTE 5: All unused inputs of the device must be held at  $V_{CC}$  or GND to ensure proper device operation. Refer to the TI application report, *Implications of Slow or Floating CMOS Inputs*, literature number SCBA004.

# SN54LV4066A, SN74LV4066A QUADRUPLE BILATERAL ANALOG SWITCHES

SCLS4271 – APRIL 1999 – REVISED APRIL 2005

electrical characteristics over recommended operating free-air temperature range (unless otherwise noted)

PARAMETER	TEST CONDITIONS	V <sub>CC</sub>	T <sub>A</sub> = 25°C			SN54LV4066A		SN74LV4066A		UNIT	
			MIN	TYP	MAX	MIN	MAX	MIN	MAX		
r <sub>on</sub> On-state switch resistance	I <sub>T</sub> = -1 mA, V <sub>I</sub> = V <sub>CC</sub> or GND, V <sub>C</sub> = V <sub>IH</sub> (see Figure 1)	2.3 V		38	180		225		225	Ω	
		3 V		29	150		190		190		
		4.5 V		21	75		100		100		
r <sub>on(p)</sub> Peak on-state resistance	I <sub>T</sub> = -1 mA, V <sub>I</sub> = V <sub>CC</sub> to GND, V <sub>C</sub> = V <sub>IH</sub>	2.3 V		143	500		600		600	Ω	
		3 V		57	180		225		225		
		4.5 V		31	100		125		125		
Δr <sub>on</sub> Difference in on-state resistance between switches	I <sub>T</sub> = -1 mA, V <sub>I</sub> = V <sub>CC</sub> to GND, V <sub>C</sub> = V <sub>IH</sub>	2.3 V		6	30		40		40	Ω	
		3 V		3	20		30		30		
		4.5 V		2	15		20		20		
I <sub>I</sub> Control input current	V <sub>I</sub> = 5.5 V or GND	0 to 5.5 V				±0.1		±1		±1	μA
I <sub>S(off)</sub> Off-state switch leakage current	V <sub>I</sub> = V <sub>CC</sub> and V <sub>O</sub> = GND, or V <sub>I</sub> = GND and V <sub>O</sub> = V <sub>CC</sub> , V <sub>C</sub> = V <sub>IL</sub> (see Figure 2)	5.5 V				±0.1		±1		±1	μA
I <sub>S(on)</sub> On-state switch leakage current	V <sub>I</sub> = V <sub>CC</sub> or GND, V <sub>C</sub> = V <sub>IH</sub> (see Figure 3)	5.5 V				±0.1		±1		±1	μA
I <sub>CC</sub> Supply current	V <sub>I</sub> = V <sub>CC</sub> or GND	5.5 V						20		20	μA
C <sub>ic</sub> Control input capacitance					1.5						pF
C <sub>io</sub> Switch input/output capacitance					5.5						pF
C <sub>F</sub> Feed-through capacitance					0.5						pF

PRODUCT PREVIEW information concerns products in the formative or design phase of development. Characteristic data and other specifications are design goals. Texas Instruments reserves the right to change or discontinue these products without notice.



POST OFFICE BOX 655303 • DALLAS, TEXAS 75265

# SN54LV4066A, SN74LV4066A QUADRUPLE BILATERAL ANALOG SWITCHES

SCLS4271 – APRIL 1999 – REVISED APRIL 2005

**switching characteristics over recommended operating free-air temperature range,  
V<sub>CC</sub> = 2.5 V ± 0.2 V (unless otherwise noted)**

PARAMETER	FROM (INPUT)	TO (OUTPUT)	TEST CONDITIONS	T <sub>A</sub> = 25°C			SN54LV4066A		SN74LV4066A		UNIT
				MIN	TYP	MAX	MIN	MAX	MIN	MAX	
t <sub>PLH</sub> t <sub>PHL</sub>	Propagaton delay time	A or B	B or A	C <sub>L</sub> = 15 pF, (see Figure 4)	1.2	10	16	16	16	16	ns
t <sub>PZH</sub> t <sub>PZL</sub>	Switch turn-on time	C	A or B	C <sub>L</sub> = 15 pF, R <sub>L</sub> = 1 kΩ (see Figure 5)	3.3	15	20	20	20	20	ns
t <sub>PLZ</sub> t <sub>PHZ</sub>	Switch turn-off time	C	A or B	C <sub>L</sub> = 15 pF, R <sub>L</sub> = 1 kΩ (see Figure 5)	6	15	23	23	23	23	ns
t <sub>PLH</sub> t <sub>PHL</sub>	Propagaton delay time	A or B	B or A	C <sub>L</sub> = 50 pF, (see Figure 4)	2.6	12	18	18	18	18	ns
t <sub>PZH</sub> t <sub>PZL</sub>	Switch turn-on time	C	A or B	C <sub>L</sub> = 50 pF, R <sub>L</sub> = 1 kΩ (see Figure 5)	4.2	25	32	32	32	32	ns
t <sub>PLZ</sub> t <sub>PHZ</sub>	Switch turn-off time	C	A or B	C <sub>L</sub> = 50 pF, R <sub>L</sub> = 1 kΩ (see Figure 5)	9.6	25	32	32	32	32	ns

**switching characteristics over recommended operating free-air temperature range,  
V<sub>CC</sub> = 3.3 V ± 0.3 V (unless otherwise noted)**

PARAMETER	FROM (INPUT)	TO (OUTPUT)	TEST CONDITIONS	T <sub>A</sub> = 25°C			SN54LV4066A		SN74LV4066A		UNIT
				MIN	TYP	MAX	MIN	MAX	MIN	MAX	
t <sub>PLH</sub> t <sub>PHL</sub>	Propagaton delay time	A or B	B or A	C <sub>L</sub> = 15 pF, (see Figure 4)	0.8	6	10	10	10	10	ns
t <sub>PZH</sub> t <sub>PZL</sub>	Switch turn-on time	C	A or B	C <sub>L</sub> = 15 pF, R <sub>L</sub> = 1 kΩ (see Figure 5)	2.3	11	15	15	15	15	ns
t <sub>PLZ</sub> t <sub>PHZ</sub>	Switch turn-off time	C	A or B	C <sub>L</sub> = 15 pF, R <sub>L</sub> = 1 kΩ (see Figure 5)	4.5	11	15	15	15	15	ns
t <sub>PLH</sub> t <sub>PHL</sub>	Propagaton delay time	A or B	B or A	C <sub>L</sub> = 50 pF, (see Figure 4)	1.5	9	12	12	12	12	ns
t <sub>PZH</sub> t <sub>PZL</sub>	Switch turn-on time	C	A or B	C <sub>L</sub> = 50 pF, R <sub>L</sub> = 1 kΩ (see Figure 5)	3	18	22	22	22	22	ns
t <sub>PLZ</sub> t <sub>PHZ</sub>	Switch turn-off time	C	A or B	C <sub>L</sub> = 50 pF, R <sub>L</sub> = 1 kΩ (see Figure 5)	7.2	18	22	22	22	22	ns

PRODUCT PREVIEW information concerns products in the formative or design phase of development. Characteristic data and other specifications are design goals. Texas Instruments reserves the right to change or discontinue these products without notice.



POST OFFICE BOX 655303 • DALLAS, TEXAS 75265

# SN54LV4066A, SN74LV4066A QUADRUPLE BILATERAL ANALOG SWITCHES

SCLS4271 – APRIL 1999 – REVISED APRIL 2005

switching characteristics over recommended operating free-air temperature range,  
 $V_{CC} = 5\text{ V} \pm 0.5\text{ V}$  (unless otherwise noted)

PARAMETER	FROM (INPUT)	TO (OUTPUT)	TEST CONDITIONS	$T_A = 25^\circ\text{C}$			SN54LV4066A		SN74LV4066A		UNIT
				MIN	TYP	MAX	MIN	MAX	MIN	MAX	
$t_{PLH}$ $t_{PHL}$ Propagation delay time	A or B	B or A	$C_L = 15\text{ pF}$ , (see Figure 4)		0.3	4		7		7	ns
$t_{PZH}$ $t_{PZL}$ Switch turn-on time	C	A or B	$C_L = 15\text{ pF}$ , $R_L = 1\text{ k}\Omega$ (see Figure 5)		1.6	7		10		10	ns
$t_{PLZ}$ $t_{PHZ}$ Switch turn-off time	C	A or B	$C_L = 15\text{ pF}$ , $R_L = 1\text{ k}\Omega$ (see Figure 5)		3.2	7		10		10	ns
$t_{PLH}$ $t_{PHL}$ Propagation delay time	A or B	B or A	$C_L = 50\text{ pF}$ , (see Figure 4)		0.6	6		8		8	ns
$t_{PZH}$ $t_{PZL}$ Switch turn-on time	C	A or B	$C_L = 50\text{ pF}$ , $R_L = 1\text{ k}\Omega$ (see Figure 5)		2.1	12		16		16	ns
$t_{PLZ}$ $t_{PHZ}$ Switch turn-off time	C	A or B	$C_L = 50\text{ pF}$ , $R_L = 1\text{ k}\Omega$ (see Figure 5)		5.1	12		16		16	ns

analog switch characteristics over operating free-air temperature range (unless otherwise noted)

PARAMETER	FROM (INPUT)	TO (OUTPUT)	TEST CONDITIONS	$V_{CC}$	$T_A = 25^\circ\text{C}$			UNIT
					MIN	TYP	MAX	
Frequency response (switch on)	A or B	B or A	$C_L = 50\text{ pF}$ , $R_L = 600\ \Omega$ , $f_{in} = 1\text{ MHz}$ (sine wave) $20\log_{10}(V_O/V_I) = -3\text{ dB}$ (see Figure 6)	2.3 V	30			MHz
				3 V	35			
				4.5 V	50			
Crosstalk (between any switches)	A or B	B or A	$C_L = 50\text{ pF}$ , $R_L = 600\ \Omega$ , $f_{in} = 1\text{ MHz}$ (sine wave) (see Figure 7)	2.3 V	-45			dB
				3 V	-45			
				4.5 V	-45			
Crosstalk (control input to signal output)	C	A or B	$C_L = 50\text{ pF}$ , $R_L = 600\ \Omega$ , $f_{in} = 1\text{ MHz}$ (square wave) (see Figure 8)	2.3 V	15			mV
				3 V	20			
				4.5 V	50			
Feed-through attenuation (switch off)	A or B	B or A	$C_L = 50\text{ pF}$ , $R_L = 600\ \Omega$ , $f_{in} = 1\text{ MHz}$ (see Figure 9)	2.3 V	-40			dB
				3 V	-40			
				4.5 V	-40			
Sine-wave distortion	A or B	B or A	$C_L = 50\text{ pF}$ , $R_L = 10\text{ k}\Omega$ , $f_{in} = 1\text{ kHz}$ (sine wave) (see Figure 10)	$V_I = 2\text{ V}_{p-p}$	2.3 V	0.1		%
				$V_I = 2.5\text{ V}_{p-p}$	3 V	0.1		
				$V_I = 4\text{ V}_{p-p}$	4.5 V	0.1		

operating characteristics,  $T_A = 25^\circ\text{C}$

PARAMETER	TEST CONDITIONS	TYP	UNIT
$C_{pd}$ Power dissipation capacitance	$C_L = 50\text{ pF}$ , $f = 10\text{ MHz}$	4.5	pF

PRODUCT PREVIEW information concerns products in the formative or design phase of development. Characteristic data and other specifications are design goals. Texas Instruments reserves the right to change or discontinue these products without notice.



POST OFFICE BOX 655303 • DALLAS, TEXAS 75265

PARAMETER MEASUREMENT INFORMATION

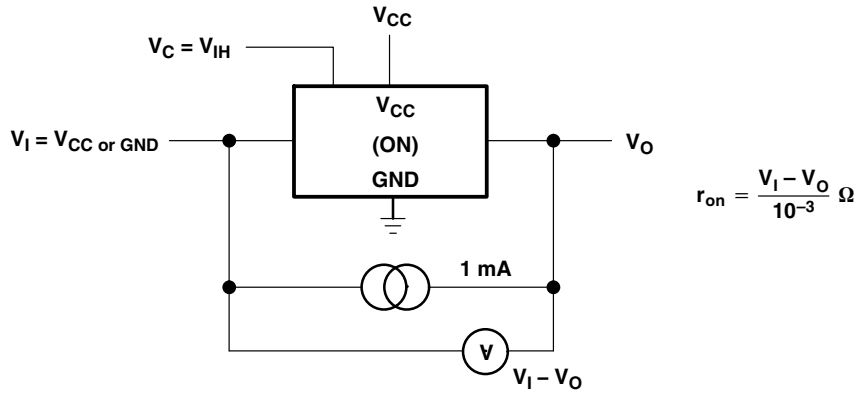

Figure 1. On-State Resistance Test Circuit

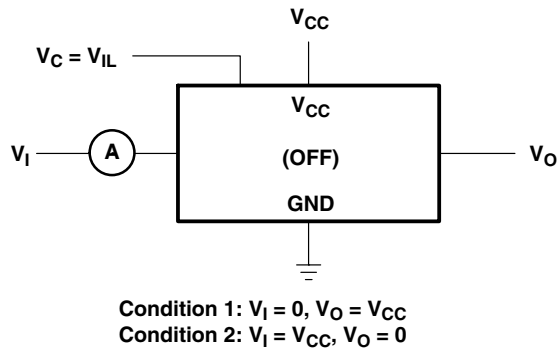

Figure 2. Off-State Switch Leakage-Current Test Circuit

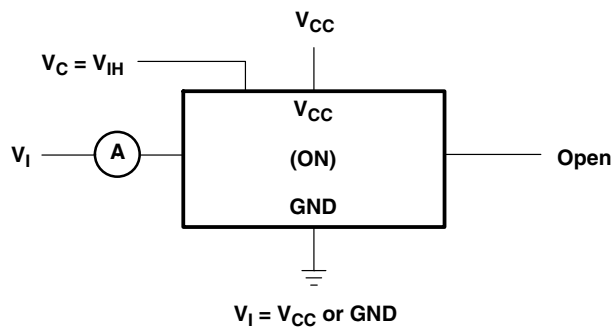
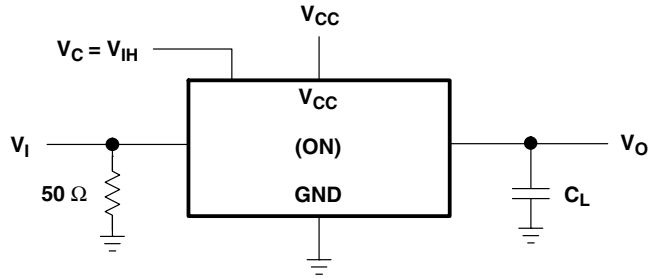

Figure 3. On-State Leakage-Current Test Circuit

# SN54LV4066A, SN74LV4066A QUADRUPLE BILATERAL ANALOG SWITCHES

SCLS4271 – APRIL 1999 – REVISED APRIL 2005

## PARAMETER MEASUREMENT INFORMATION



TEST CIRCUIT

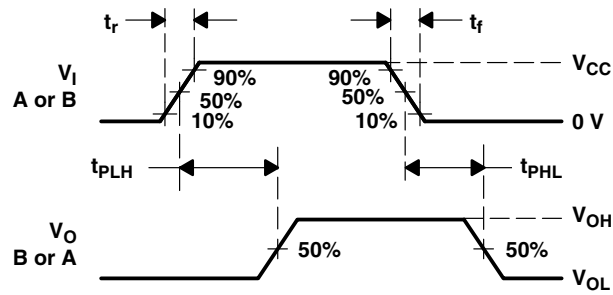

VOLTAGE WAVEFORMS

Figure 4. Propagation Delay Time, Signal Input to Signal Output

PARAMETER MEASUREMENT INFORMATION

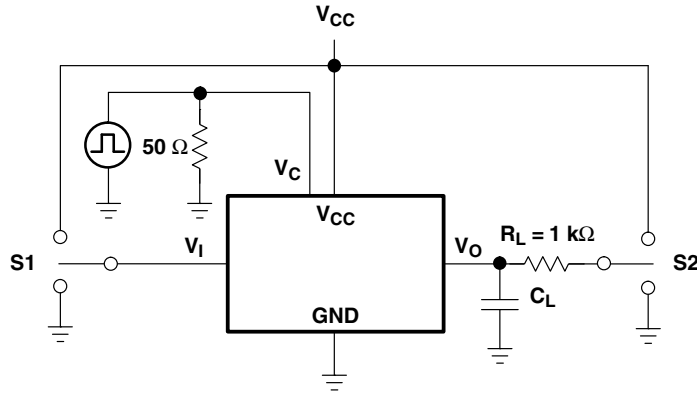

TEST	S1	S2
t <sub>PZL</sub>	GND	V <sub>CC</sub>
t <sub>PZH</sub>	V <sub>CC</sub>	GND
t <sub>PLZ</sub>	GND	V <sub>CC</sub>
t <sub>PHZ</sub>	V <sub>CC</sub>	GND

TEST CIRCUIT

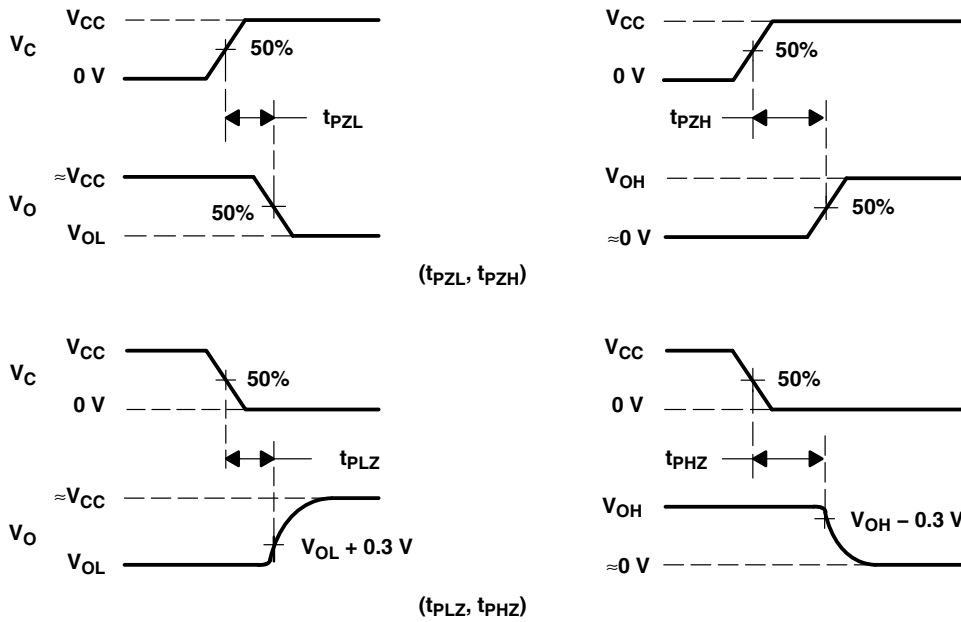

VOLTAGE WAVEFORMS

Figure 5. Switching Time (t<sub>PZL</sub>, t<sub>PLZ</sub>, t<sub>PZH</sub>, t<sub>PHZ</sub>), Control to Signal Output

# SN54LV4066A, SN74LV4066A QUADRUPLE BILATERAL ANALOG SWITCHES

SCLS4271 – APRIL 1999 – REVISED APRIL 2005

## PARAMETER MEASUREMENT INFORMATION

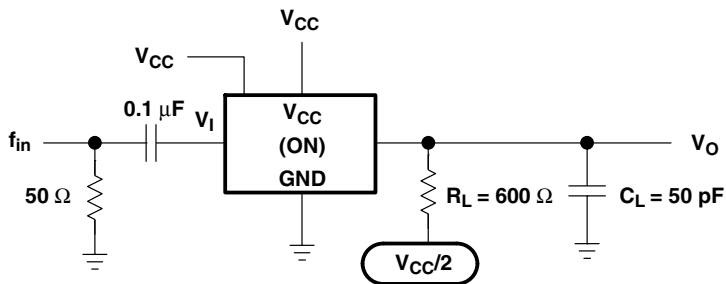

Figure 6. Frequency Response (Switch On)

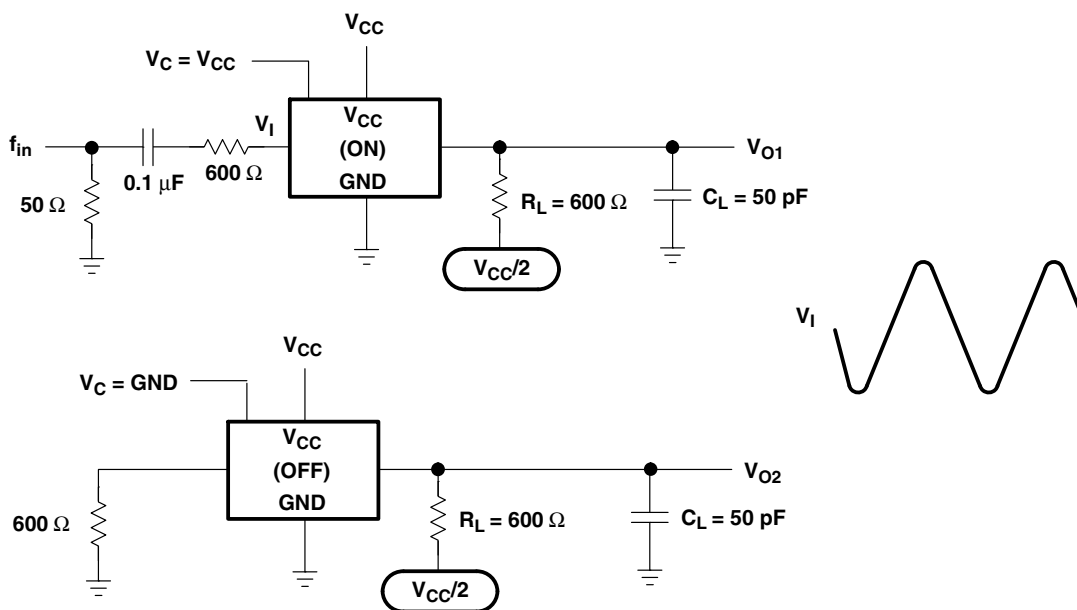

Figure 7. Crosstalk Between Any Two Switches

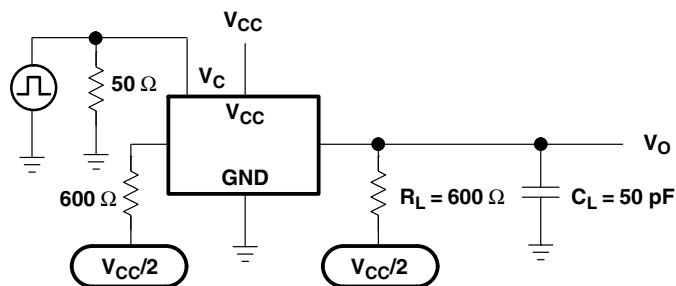

Figure 8. Crosstalk (Control Input – Switch Output)

PARAMETER MEASUREMENT INFORMATION

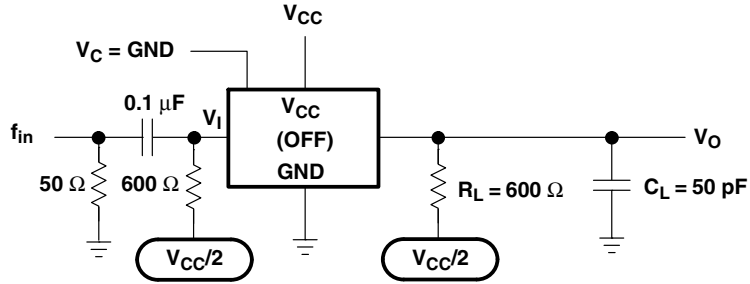

Figure 9. Feed-Through Attenuation (Switch Off)

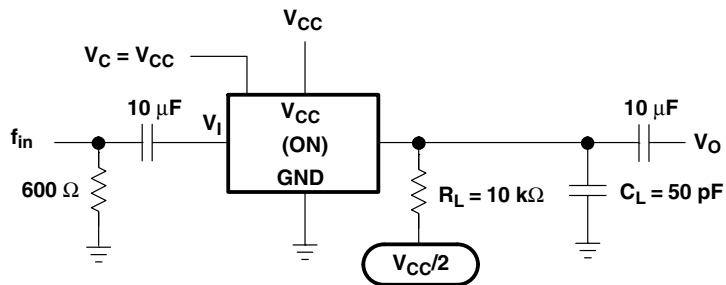

Figure 10. Sine-Wave Distortion

**PACKAGING INFORMATION**

Orderable Device	Status <sup>(1)</sup>	Package Type	Package Drawing	Pins	Package Qty	Eco Plan <sup>(2)</sup>	Lead/Ball Finish	MSL Peak Temp <sup>(3)</sup>
SN74LV4066AD	ACTIVE	SOIC	D	14	50	Green (RoHS & no Sb/Br)	CU NIPDAU	Level-1-260C-UNLIM
SN74LV4066ADBR	ACTIVE	SSOP	DB	14	2000	Green (RoHS & no Sb/Br)	CU NIPDAU	Level-1-260C-UNLIM
SN74LV4066ADBRG4	ACTIVE	SSOP	DB	14	2000	Green (RoHS & no Sb/Br)	CU NIPDAU	Level-1-260C-UNLIM
SN74LV4066ADE4	ACTIVE	SOIC	D	14	50	Green (RoHS & no Sb/Br)	CU NIPDAU	Level-1-260C-UNLIM
SN74LV4066ADG4	ACTIVE	SOIC	D	14	50	Green (RoHS & no Sb/Br)	CU NIPDAU	Level-1-260C-UNLIM
SN74LV4066ADGVR	ACTIVE	TVSOP	DGV	14	2000	Green (RoHS & no Sb/Br)	CU NIPDAU	Level-1-260C-UNLIM
SN74LV4066ADGVRE4	ACTIVE	TVSOP	DGV	14	2000	Green (RoHS & no Sb/Br)	CU NIPDAU	Level-1-260C-UNLIM
SN74LV4066ADGVRG4	ACTIVE	TVSOP	DGV	14	2000	Green (RoHS & no Sb/Br)	CU NIPDAU	Level-1-260C-UNLIM
SN74LV4066ADR	ACTIVE	SOIC	D	14	2500	Green (RoHS & no Sb/Br)	CU NIPDAU	Level-1-260C-UNLIM
SN74LV4066ADRE4	ACTIVE	SOIC	D	14	2500	Green (RoHS & no Sb/Br)	CU NIPDAU	Level-1-260C-UNLIM
SN74LV4066ADRG4	ACTIVE	SOIC	D	14	2500	Green (RoHS & no Sb/Br)	CU NIPDAU	Level-1-260C-UNLIM
SN74LV4066AN	ACTIVE	PDIP	N	14	25	Pb-Free (RoHS)	CU NIPDAU	N / A for Pkg Type
SN74LV4066ANE4	ACTIVE	PDIP	N	14	25	Pb-Free (RoHS)	CU NIPDAU	N / A for Pkg Type
SN74LV4066ANSR	ACTIVE	SO	NS	14	2000	Green (RoHS & no Sb/Br)	CU NIPDAU	Level-1-260C-UNLIM
SN74LV4066ANSRE4	ACTIVE	SO	NS	14	2000	Green (RoHS & no Sb/Br)	CU NIPDAU	Level-1-260C-UNLIM
SN74LV4066ANSRG4	ACTIVE	SO	NS	14	2000	Green (RoHS & no Sb/Br)	CU NIPDAU	Level-1-260C-UNLIM
SN74LV4066APW	ACTIVE	TSSOP	PW	14	90	Green (RoHS & no Sb/Br)	CU NIPDAU	Level-1-260C-UNLIM
SN74LV4066APWE4	ACTIVE	TSSOP	PW	14	90	Green (RoHS & no Sb/Br)	CU NIPDAU	Level-1-260C-UNLIM
SN74LV4066APWG4	ACTIVE	TSSOP	PW	14	90	Green (RoHS & no Sb/Br)	CU NIPDAU	Level-1-260C-UNLIM
SN74LV4066APWR	ACTIVE	TSSOP	PW	14	2000	Green (RoHS & no Sb/Br)	CU NIPDAU	Level-1-260C-UNLIM
SN74LV4066APWRE4	ACTIVE	TSSOP	PW	14	2000	Green (RoHS & no Sb/Br)	CU NIPDAU	Level-1-260C-UNLIM
SN74LV4066APWRG4	ACTIVE	TSSOP	PW	14	2000	Green (RoHS & no Sb/Br)	CU NIPDAU	Level-1-260C-UNLIM
SN74LV4066APWT	ACTIVE	TSSOP	PW	14	250	Green (RoHS & no Sb/Br)	CU NIPDAU	Level-1-260C-UNLIM
SN74LV4066APWTE4	ACTIVE	TSSOP	PW	14	250	Green (RoHS & no Sb/Br)	CU NIPDAU	Level-1-260C-UNLIM
SN74LV4066APWTG4	ACTIVE	TSSOP	PW	14	250	Green (RoHS & no Sb/Br)	CU NIPDAU	Level-1-260C-UNLIM

Orderable Device	Status <sup>(1)</sup>	Package Type	Package Drawing	Pins	Package Qty	Eco Plan <sup>(2)</sup>	Lead/Ball Finish	MSL Peak Temp <sup>(3)</sup>
SN74LV4066ARGYR	ACTIVE	VQFN	RGY	14	3000	Green (RoHS & no Sb/Br)	CU NIPDAU	Level-2-260C-1 YEAR
SN74LV4066ARGYRG4	ACTIVE	VQFN	RGY	14	3000	Green (RoHS & no Sb/Br)	CU NIPDAU	Level-2-260C-1 YEAR

<sup>(1)</sup> The marketing status values are defined as follows:

**ACTIVE:** Product device recommended for new designs.

**LIFEBUY:** TI has announced that the device will be discontinued, and a lifetime-buy period is in effect.

**NRND:** Not recommended for new designs. Device is in production to support existing customers, but TI does not recommend using this part in a new design.

**PREVIEW:** Device has been announced but is not in production. Samples may or may not be available.

**OBSOLETE:** TI has discontinued the production of the device.

<sup>(2)</sup> Eco Plan - The planned eco-friendly classification: Pb-Free (RoHS), Pb-Free (RoHS Exempt), or Green (RoHS & no Sb/Br) - please check <http://www.ti.com/productcontent> for the latest availability information and additional product content details.

**TBD:** The Pb-Free/Green conversion plan has not been defined.

**Pb-Free (RoHS):** TI's terms "Lead-Free" or "Pb-Free" mean semiconductor products that are compatible with the current RoHS requirements for all 6 substances, including the requirement that lead not exceed 0.1% by weight in homogeneous materials. Where designed to be soldered at high temperatures, TI Pb-Free products are suitable for use in specified lead-free processes.

**Pb-Free (RoHS Exempt):** This component has a RoHS exemption for either 1) lead-based flip-chip solder bumps used between the die and package, or 2) lead-based die adhesive used between the die and leadframe. The component is otherwise considered Pb-Free (RoHS compatible) as defined above.

**Green (RoHS & no Sb/Br):** TI defines "Green" to mean Pb-Free (RoHS compatible), and free of Bromine (Br) and Antimony (Sb) based flame retardants (Br or Sb do not exceed 0.1% by weight in homogeneous material)

<sup>(3)</sup> MSL, Peak Temp. -- The Moisture Sensitivity Level rating according to the JEDEC industry standard classifications, and peak solder temperature.

**Important Information and Disclaimer:**The information provided on this page represents TI's knowledge and belief as of the date that it is provided. TI bases its knowledge and belief on information provided by third parties, and makes no representation or warranty as to the accuracy of such information. Efforts are underway to better integrate information from third parties. TI has taken and continues to take reasonable steps to provide representative and accurate information but may not have conducted destructive testing or chemical analysis on incoming materials and chemicals. TI and TI suppliers consider certain information to be proprietary, and thus CAS numbers and other limited information may not be available for release.

In no event shall TI's liability arising out of such information exceed the total purchase price of the TI part(s) at issue in this document sold by TI to Customer on an annual basis.

**TAPE AND REEL INFORMATION**

**QUADRANT ASSIGNMENTS FOR PIN 1 ORIENTATION IN TAPE**

\*All dimensions are nominal

Device	Package Type	Package Drawing	Pins	SPQ	Reel Diameter (mm)	Reel Width W1 (mm)	A0 (mm)	B0 (mm)	K0 (mm)	P1 (mm)	W (mm)	Pin1 Quadrant
SN74LV4066ADBR	SSOP	DB	14	2000	330.0	16.4	8.2	6.6	2.5	12.0	16.0	Q1
SN74LV4066ADGVR	TVSOP	DGV	14	2000	330.0	12.4	6.8	4.0	1.6	8.0	12.0	Q1
SN74LV4066ADR	SOIC	D	14	2500	330.0	16.4	6.5	9.0	2.1	8.0	16.0	Q1
SN74LV4066ANSR	SO	NS	14	2000	330.0	16.4	8.2	10.5	2.5	12.0	16.0	Q1
SN74LV4066APWR	TSSOP	PW	14	2000	330.0	12.4	6.9	5.6	1.6	8.0	12.0	Q1
SN74LV4066APWT	TSSOP	PW	14	250	330.0	12.4	6.9	5.6	1.6	8.0	12.0	Q1
SN74LV4066ARGYR	VQFN	RGY	14	3000	330.0	12.4	3.75	3.75	1.15	8.0	12.0	Q1

**TAPE AND REEL BOX DIMENSIONS**

\*All dimensions are nominal

Device	Package Type	Package Drawing	Pins	SPQ	Length (mm)	Width (mm)	Height (mm)
SN74LV4066ADBR	SSOP	DB	14	2000	346.0	346.0	33.0
SN74LV4066ADGVR	TVSOP	DGV	14	2000	346.0	346.0	29.0
SN74LV4066ADR	SOIC	D	14	2500	346.0	346.0	33.0
SN74LV4066ANSR	SO	NS	14	2000	346.0	346.0	33.0
SN74LV4066APWR	TSSOP	PW	14	2000	346.0	346.0	29.0
SN74LV4066APWT	TSSOP	PW	14	250	346.0	346.0	29.0
SN74LV4066ARGYR	VQFN	RGY	14	3000	346.0	346.0	29.0

N (R-PDIP-T\*\*)

PLASTIC DUAL-IN-LINE PACKAGE

16 PINS SHOWN



- NOTES:
- A. All linear dimensions are in inches (millimeters).
  - B. This drawing is subject to change without notice.
  - $\triangle C$  Falls within JEDEC MS-001, except 18 and 20 pin minimum body length (Dim A).
  - $\triangle D$  The 20 pin end lead shoulder width is a vendor option, either half or full width.

4040049/E 12/2002

DGV (R-PDSO-G\*\*)

PLASTIC SMALL-OUTLINE

24 PINS SHOWN



- NOTES: A. All linear dimensions are in millimeters.  
 B. This drawing is subject to change without notice.  
 C. Body dimensions do not include mold flash or protrusion, not to exceed 0,15 per side.  
 D. Falls within JEDEC: 24/48 Pins – MO-153  
 14/16/20/56 Pins – MO-194

D (R-PDSO-G14)

PLASTIC SMALL OUTLINE



- NOTES:
- A. All linear dimensions are in inches (millimeters).
  - B. This drawing is subject to change without notice.
  -  Body length does not include mold flash, protrusions, or gate burrs. Mold flash, protrusions, or gate burrs shall not exceed 0.006 (0,15) each side.
  -  Body width does not include interlead flash. Interlead flash shall not exceed 0.017 (0,43) each side.
  - E. Reference JEDEC MS-012 variation AB.

D (R-PDSO-G14)

PLASTIC SMALL OUTLINE

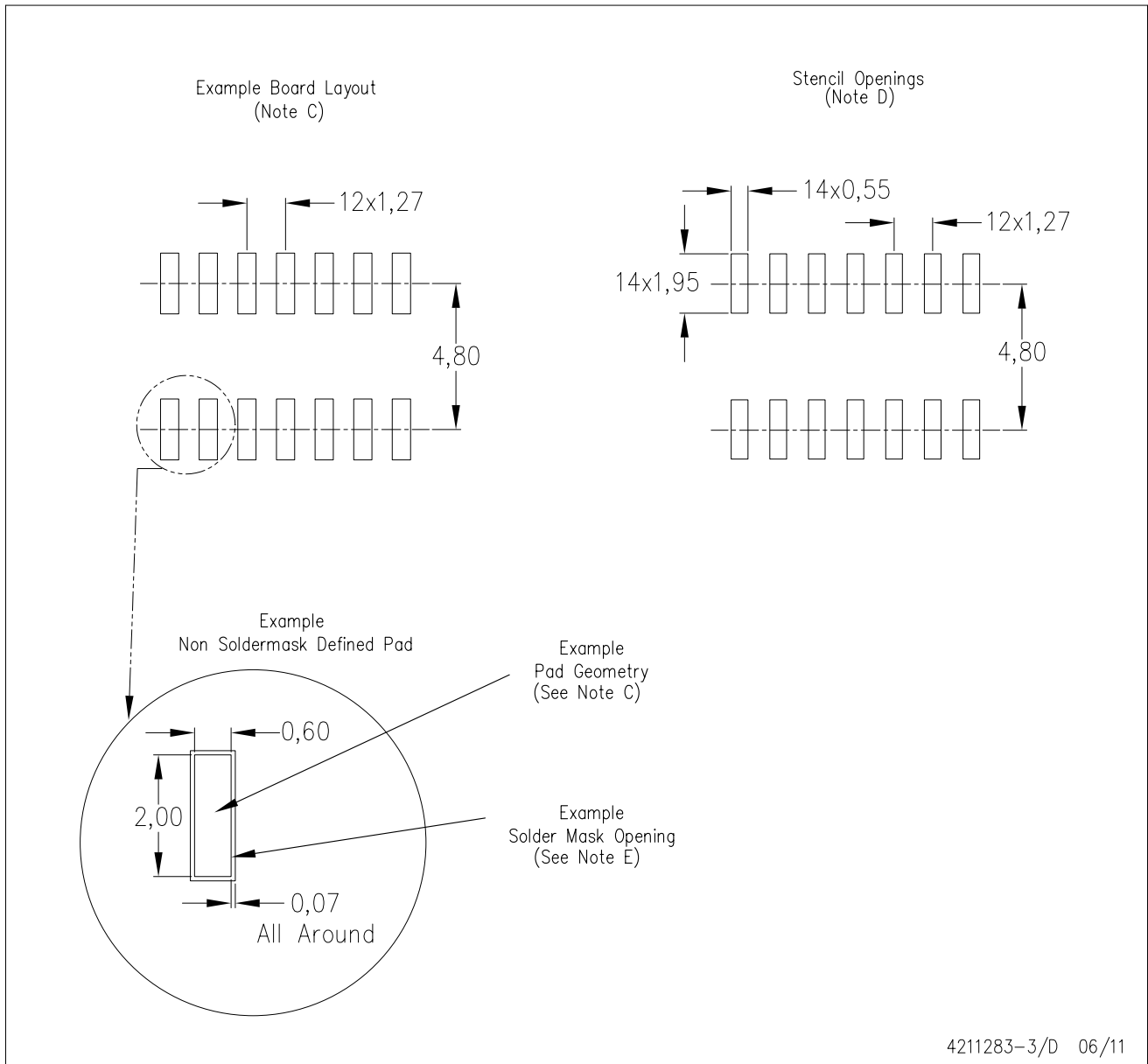

- NOTES:
- A. All linear dimensions are in millimeters.
  - B. This drawing is subject to change without notice.
  - C. Publication IPC-7351 is recommended for alternate designs.
  - D. Laser cutting apertures with trapezoidal walls and also rounding corners will offer better paste release. Customers should contact their board assembly site for stencil design recommendations. Refer to IPC-7525 for other stencil recommendations.
  - E. Customers should contact their board fabrication site for solder mask tolerances between and around signal pads.



PW (R-PDSO-G14)

PLASTIC SMALL OUTLINE

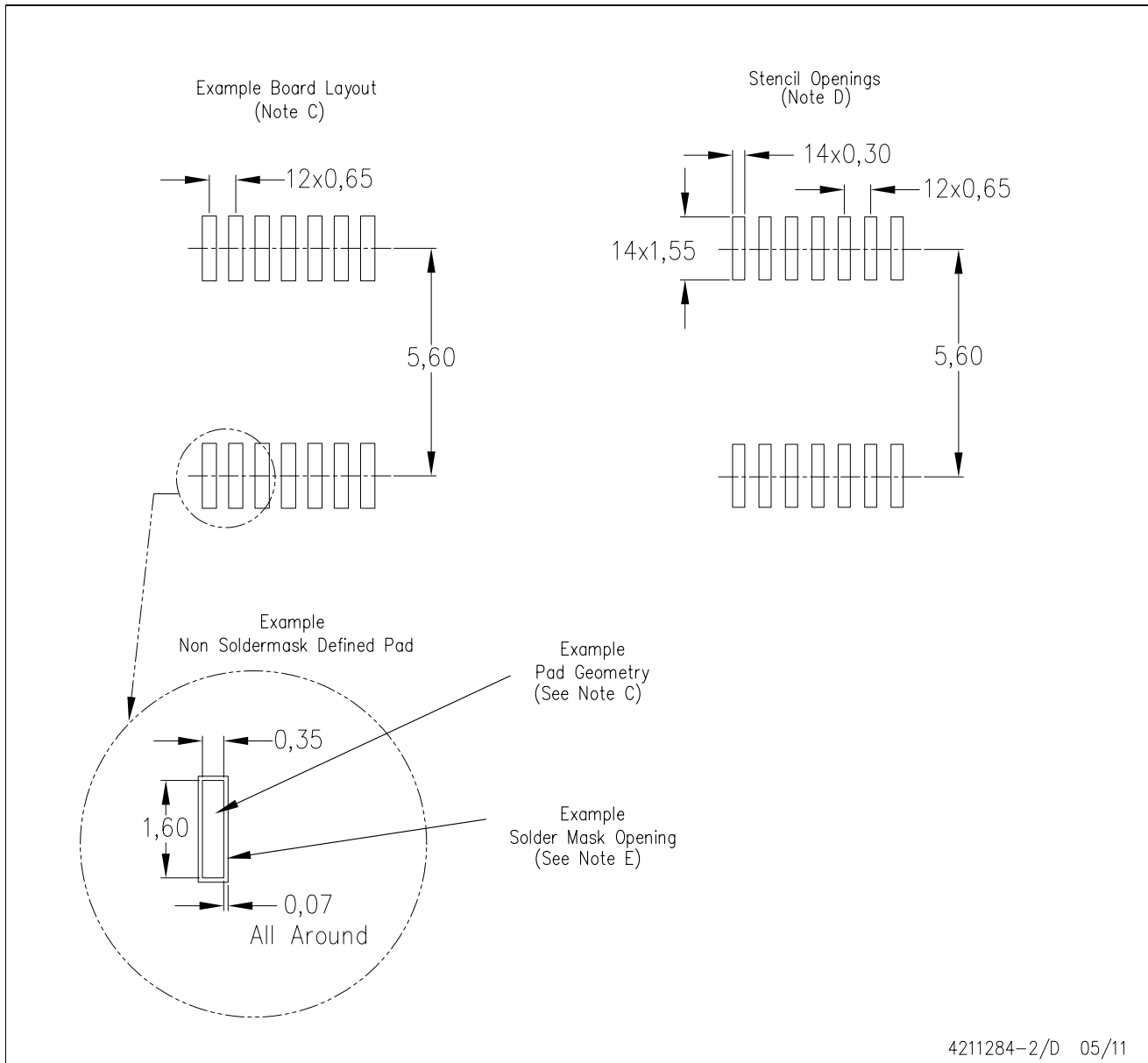

- NOTES:
- All linear dimensions are in millimeters.
  - This drawing is subject to change without notice.
  - Publication IPC-7351 is recommended for alternate designs.
  - Laser cutting apertures with trapezoidal walls and also rounding corners will offer better paste release. Customers should contact their board assembly site for stencil design recommendations. Refer to IPC-7525 for other stencil recommendations.
  - Customers should contact their board fabrication site for solder mask tolerances between and around signal pads.

RGY (S-PVQFN-N14)

PLASTIC QUAD FLATPACK NO-LEAD



- NOTES:
- A. All linear dimensions are in millimeters. Dimensioning and tolerancing per ASME Y14.5M-1994.
  - B. This drawing is subject to change without notice.
  - C. QFN (Quad Flatpack No-Lead) package configuration.
  - D. The package thermal pad must be soldered to the board for thermal and mechanical performance.
  - E. See the additional figure in the Product Data Sheet for details regarding the exposed thermal pad features and dimensions.
  -  Pin 1 identifiers are located on both top and bottom of the package and within the zone indicated. The Pin 1 identifiers are either a molded, marked, or metal feature.
  - G. Package complies to JEDEC MO-241 variation BA.

RGY (S-PVQFN-N14)

PLASTIC QUAD FLATPACK NO-LEAD

**THERMAL INFORMATION**

This package incorporates an exposed thermal pad that is designed to be attached directly to an external heatsink. The thermal pad must be soldered directly to the printed circuit board (PCB). After soldering, the PCB can be used as a heatsink. In addition, through the use of thermal vias, the thermal pad can be attached directly to the appropriate copper plane shown in the electrical schematic for the device, or alternatively, can be attached to a special heatsink structure designed into the PCB. This design optimizes the heat transfer from the integrated circuit (IC).

For information on the Quad Flatpack No-Lead (QFN) package and its advantages, refer to Application Report, QFN/SON PCB Attachment, Texas Instruments Literature No. SLUA271. This document is available at [www.ti.com](http://www.ti.com).

The exposed thermal pad dimensions for this package are shown in the following illustration.

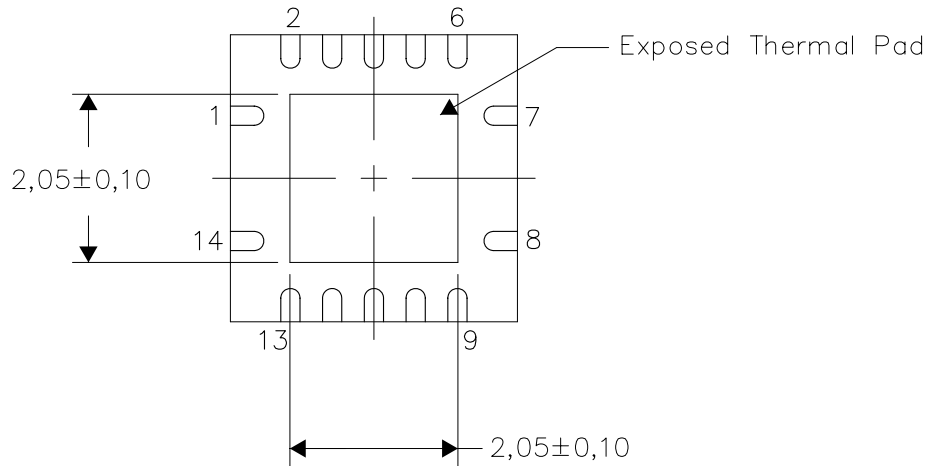

Bottom View

Exposed Thermal Pad Dimensions

4206353-2/N 06/11

NOTE: A. All linear dimensions are in millimeters

RGY (S-PVQFN-N14)

PLASTIC QUAD FLATPACK NO-LEAD

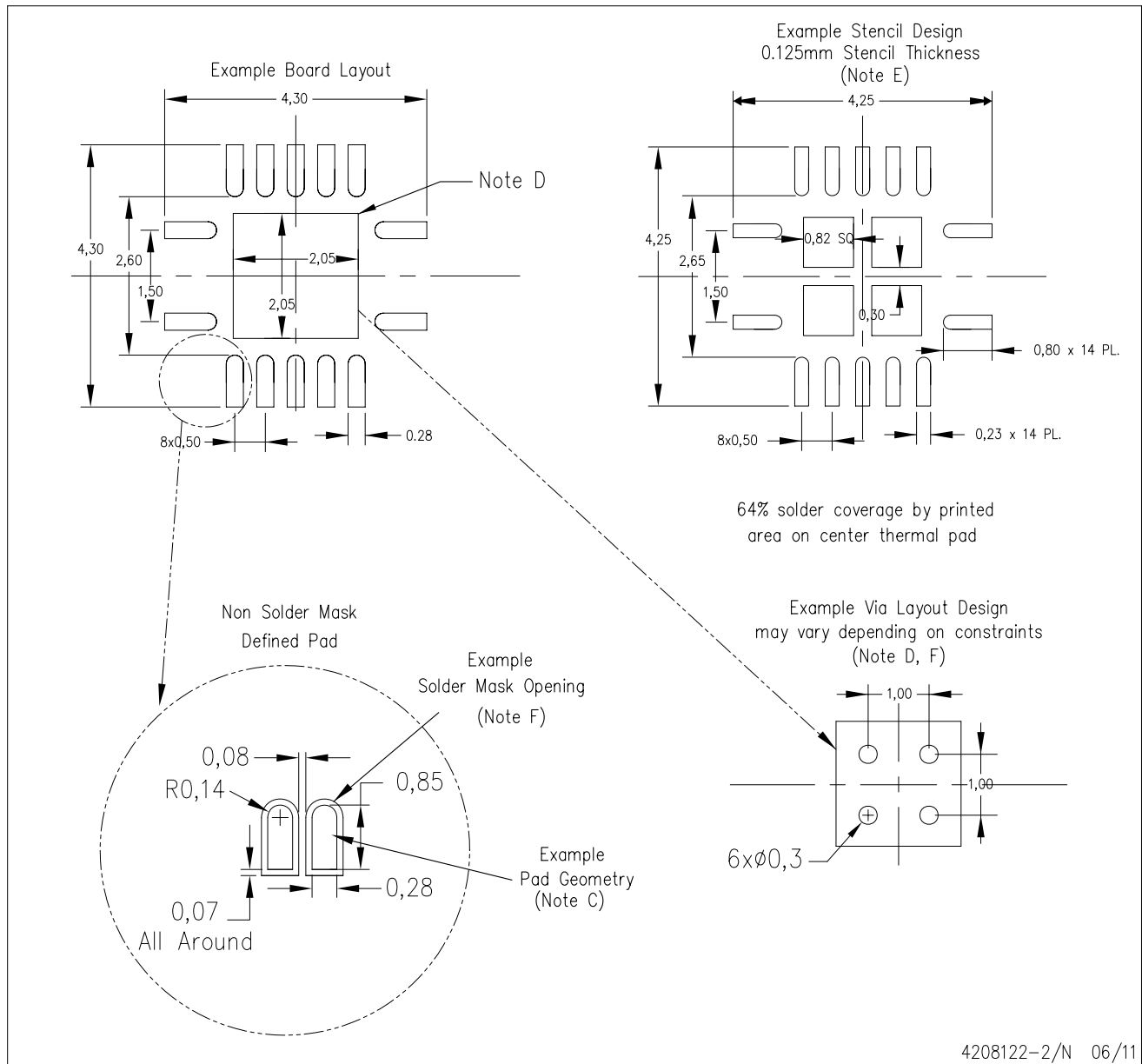

- NOTES:
- A. All linear dimensions are in millimeters.
  - B. This drawing is subject to change without notice.
  - C. Publication IPC-7351 is recommended for alternate designs.
  - D. This package is designed to be soldered to a thermal pad on the board. Refer to Application Note, Quad Flat-Pack QFN/SON PCB Attachment, Texas Instruments Literature No. SLUA271, and also the Product Data Sheets for specific thermal information, via requirements, and recommended board layout. These documents are available at [www.ti.com](http://www.ti.com) <<http://www.ti.com>>.
  - E. Laser cutting apertures with trapezoidal walls and also rounding corners will offer better paste release. Customers should contact their board assembly site for stencil design recommendations. Refer to IPC 7525 for stencil design considerations.
  - F. Customers should contact their board fabrication site for minimum solder mask web tolerances between signal pads.

# MECHANICAL DATA

NS (R-PDSO-G\*\*)

PLASTIC SMALL-OUTLINE PACKAGE

14-PINS SHOWN



- NOTES:
- A. All linear dimensions are in millimeters.
  - B. This drawing is subject to change without notice.
  - C. Body dimensions do not include mold flash or protrusion, not to exceed 0,15.



## IMPORTANT NOTICE

Texas Instruments Incorporated and its subsidiaries (TI) reserve the right to make corrections, modifications, enhancements, improvements, and other changes to its products and services at any time and to discontinue any product or service without notice. Customers should obtain the latest relevant information before placing orders and should verify that such information is current and complete. All products are sold subject to TI's terms and conditions of sale supplied at the time of order acknowledgment.

TI warrants performance of its hardware products to the specifications applicable at the time of sale in accordance with TI's standard warranty. Testing and other quality control techniques are used to the extent TI deems necessary to support this warranty. Except where mandated by government requirements, testing of all parameters of each product is not necessarily performed.

TI assumes no liability for applications assistance or customer product design. Customers are responsible for their products and applications using TI components. To minimize the risks associated with customer products and applications, customers should provide adequate design and operating safeguards.

TI does not warrant or represent that any license, either express or implied, is granted under any TI patent right, copyright, mask work right, or other TI intellectual property right relating to any combination, machine, or process in which TI products or services are used. Information published by TI regarding third-party products or services does not constitute a license from TI to use such products or services or a warranty or endorsement thereof. Use of such information may require a license from a third party under the patents or other intellectual property of the third party, or a license from TI under the patents or other intellectual property of TI.

Reproduction of TI information in TI data books or data sheets is permissible only if reproduction is without alteration and is accompanied by all associated warranties, conditions, limitations, and notices. Reproduction of this information with alteration is an unfair and deceptive business practice. TI is not responsible or liable for such altered documentation. Information of third parties may be subject to additional restrictions.

Resale of TI products or services with statements different from or beyond the parameters stated by TI for that product or service voids all express and any implied warranties for the associated TI product or service and is an unfair and deceptive business practice. TI is not responsible or liable for any such statements.

TI products are not authorized for use in safety-critical applications (such as life support) where a failure of the TI product would reasonably be expected to cause severe personal injury or death, unless officers of the parties have executed an agreement specifically governing such use. Buyers represent that they have all necessary expertise in the safety and regulatory ramifications of their applications, and acknowledge and agree that they are solely responsible for all legal, regulatory and safety-related requirements concerning their products and any use of TI products in such safety-critical applications, notwithstanding any applications-related information or support that may be provided by TI. Further, Buyers must fully indemnify TI and its representatives against any damages arising out of the use of TI products in such safety-critical applications.

TI products are neither designed nor intended for use in military/aerospace applications or environments unless the TI products are specifically designated by TI as military-grade or "enhanced plastic." Only products designated by TI as military-grade meet military specifications. Buyers acknowledge and agree that any such use of TI products which TI has not designated as military-grade is solely at the Buyer's risk, and that they are solely responsible for compliance with all legal and regulatory requirements in connection with such use.

TI products are neither designed nor intended for use in automotive applications or environments unless the specific TI products are designated by TI as compliant with ISO/TS 16949 requirements. Buyers acknowledge and agree that, if they use any non-designated products in automotive applications, TI will not be responsible for any failure to meet such requirements.

Following are URLs where you can obtain information on other Texas Instruments products and application solutions:

### Products

Audio	<a href="http://www.ti.com/audio">www.ti.com/audio</a>
Amplifiers	<a href="http://amplifier.ti.com">amplifier.ti.com</a>
Data Converters	<a href="http://dataconverter.ti.com">dataconverter.ti.com</a>
DLP® Products	<a href="http://www.dlp.com">www.dlp.com</a>
DSP	<a href="http://dsp.ti.com">dsp.ti.com</a>
Clocks and Timers	<a href="http://www.ti.com/clocks">www.ti.com/clocks</a>
Interface	<a href="http://interface.ti.com">interface.ti.com</a>
Logic	<a href="http://logic.ti.com">logic.ti.com</a>
Power Mgmt	<a href="http://power.ti.com">power.ti.com</a>
Microcontrollers	<a href="http://microcontroller.ti.com">microcontroller.ti.com</a>
RFID	<a href="http://www.ti-rfid.com">www.ti-rfid.com</a>
RF/IF and ZigBee® Solutions	<a href="http://www.ti.com/lprf">www.ti.com/lprf</a>

### Applications

Communications and Telecom	<a href="http://www.ti.com/communications">www.ti.com/communications</a>
Computers and Peripherals	<a href="http://www.ti.com/computers">www.ti.com/computers</a>
Consumer Electronics	<a href="http://www.ti.com/consumer-apps">www.ti.com/consumer-apps</a>
Energy and Lighting	<a href="http://www.ti.com/energy">www.ti.com/energy</a>
Industrial	<a href="http://www.ti.com/industrial">www.ti.com/industrial</a>
Medical	<a href="http://www.ti.com/medical">www.ti.com/medical</a>
Security	<a href="http://www.ti.com/security">www.ti.com/security</a>
Space, Avionics and Defense	<a href="http://www.ti.com/space-avionics-defense">www.ti.com/space-avionics-defense</a>
Transportation and Automotive	<a href="http://www.ti.com/automotive">www.ti.com/automotive</a>
Video and Imaging	<a href="http://www.ti.com/video">www.ti.com/video</a>
Wireless	<a href="http://www.ti.com/wireless-apps">www.ti.com/wireless-apps</a>

TI E2E Community Home Page

[e2e.ti.com](http://e2e.ti.com)

Mailing Address: Texas Instruments, Post Office Box 655303, Dallas, Texas 75265  
Copyright © 2011, Texas Instruments Incorporated