

SN54LV157A, SN74LV157A

QUADRUPLE 2-LINE TO 1-LINE DATA SELECTORS/MULTIPLEXERS

SCLS397D – APRIL 1998 – REVISED JULY 2003

- 2-V to 5.5-V V_{CC} Operation
- Max t_{pd} of 7.5 ns at 5 V
- Typical V_{OLP} (Output Ground Bounce) <math><0.8\text{ V}</math> at V_{CC} , $T_A = 25^\circ\text{C}$
- Typical V_{OHV} (Output V_{OH} Undershoot) >math>>2.3\text{ V}</math> at V_{CC} , $T_A = 25^\circ\text{C}$
- I_{off} Supports Partial-Power-Down-Mode Operation
- Latch-Up Performance Exceeds 100 mA Per JESD 78, Class II
- ESD Protection Exceeds JESD 22
 - 2000-V Human-Body Model (A114-A)
 - 200-V Machine Model (A115-A)
 - 1000-V Charged-Device Model (C101)

SN54LV157A ... J OR W PACKAGE
SN74LV157A ... D, DB, DGV, NS, OR PW PACKAGE
(TOP VIEW)

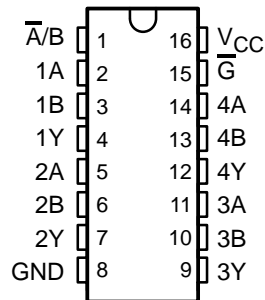

SN54LV157A ... FK PACKAGE
(TOP VIEW)

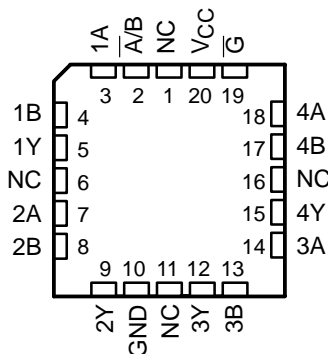

NC – No internal connection

description/ordering information

The 'LV157A devices are quadruple 2-line to 1-line data selectors/multiplexers designed for 2-V to 5.5-V V_{CC} operation.

These devices contain inverters and drivers to supply full data selection to the four output gates. A separate strobe (\bar{G}) input is provided. A 4-bit word is selected from one of two sources and is routed to the four outputs. The 'LV157A devices present true data.

ORDERING INFORMATION

T_A	PACKAGE†		ORDERABLE PART NUMBER	TOP-SIDE MARKING
–40°C to 85°C	SOIC – D	Tube of 40	SN74LV157AD	LV157A
		Reel of 2500	SN74LV157ADR	
	SOP – NS	Reel of 2000	SN74LV157ANSR	74LV157A
	SSOP – DB	Reel of 2000	SN74LV157ADBR	LV157A
	TSSOP – PW	Tube of 90	SN74LV157APW	LV157A
		Reel of 2000	SN74LV157APWR	
Reel of 250		SN74LV157APWT		
	TVSOP – DGV	Reel of 2000	SN74LV157ADGVR	LV157A
–55°C to 125°C	CDIP – J	Tube of 25	SNJ54LV157AJ	SNJ54LV157AJ
	CFP – W	Tube of 150	SNJ54LV157AW	SNJ54LV157AW
	LCCC – FK	Tube of 55	SNJ54LV157AFK	SNJ54LV157AFK

† Package drawings, standard packing quantities, thermal data, symbolization, and PCB design guidelines are available at www.ti.com/sc/package.



Please be aware that an important notice concerning availability, standard warranty, and use in critical applications of Texas Instruments semiconductor products and disclaimers thereto appears at the end of this data sheet.

UNLESS OTHERWISE NOTED this document contains PRODUCTION DATA information current as of publication date. Products conform to specifications per the terms of Texas Instruments standard warranty. Production processing does not necessarily include testing of all parameters.

**TEXAS
INSTRUMENTS**

POST OFFICE BOX 655303 • DALLAS, TEXAS 75265

Copyright © 2003, Texas Instruments Incorporated

SN54LV157A, SN74LV157A QUADRUPLE 2-LINE TO 1-LINE DATA SELECTORS/MULTIPLEXERS

SCLS397D – APRIL 1998 – REVISED JULY 2003

description/ordering information (continued)

These devices are fully specified for partial-power-down applications using I_{off} . The I_{off} circuitry disables the outputs, preventing damaging current backflow through the devices when they are powered down.

FUNCTION TABLE

INPUTS				OUTPUT Y
\overline{G}	SELECT $\overline{A/B}$	DATA		
		A	B	
H	X	X	X	L
L	L	L	X	L
L	L	H	X	H
L	H	X	L	L
L	H	X	H	H

logic diagram (positive logic)

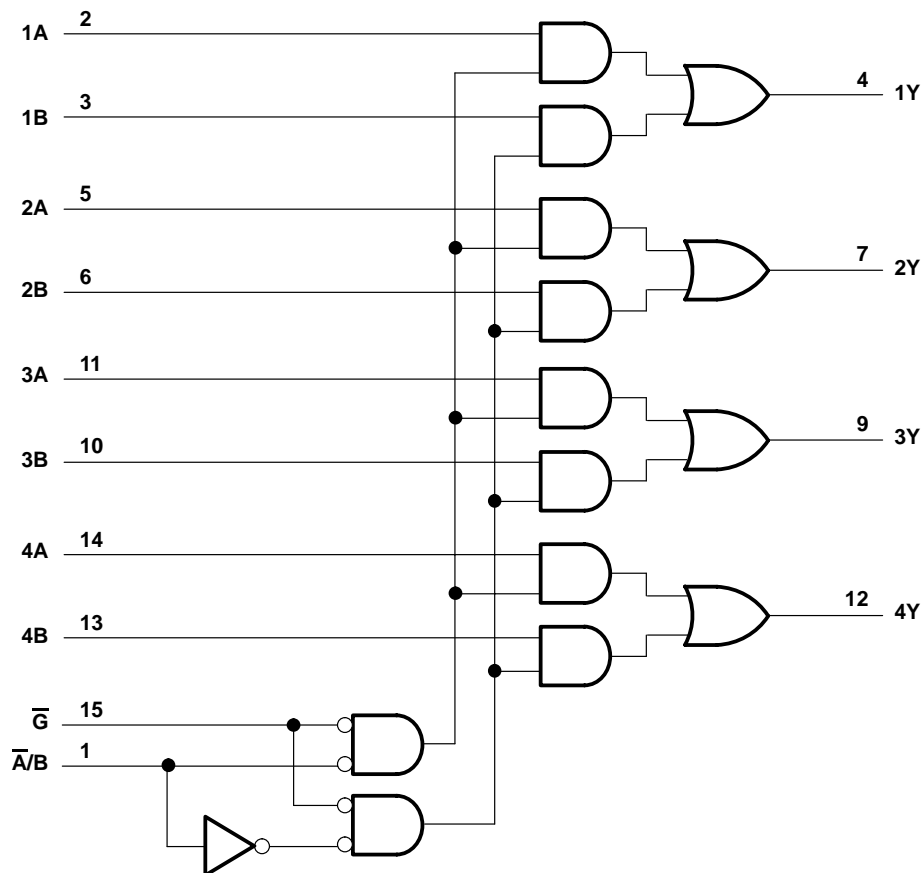

Pin numbers shown are for the D, DB, DGV, J, NS, PW, and W packages.

SN54LV157A, SN74LV157A QUADRUPLE 2-LINE TO 1-LINE DATA SELECTORS/MULTIPLEXERS

SCLS397D – APRIL 1998 – REVISED JULY 2003

absolute maximum ratings over operating free-air temperature range (unless otherwise noted)†

Supply voltage range, V_{CC}	–0.5 V to 7 V
Input voltage range, V_I (see Note 1)	–0.5 V to 7 V
Output voltage range applied in high or low state, V_O (see Notes 1 and 2)	–0.5 V to $V_{CC} + 0.5$ V
Output voltage range applied in power-off state, V_O (see Note 1)	–0.5 V to 7 V
Input clamp current, I_{IK} ($V_I < 0$)	–20 mA
Output clamp current, I_{OK} ($V_O < 0$ or $V_O > V_{CC}$)	±50 mA
Continuous output current, I_O ($V_O = 0$ to V_{CC})	±25 mA
Continuous current through V_{CC} or GND	±50 mA
Package thermal impedance, θ_{JA} (see Note 3):	
D package	73°C/W
DB package	82°C/W
DGV package	120°C/W
NS package	64°C/W
PW package	108°C/W
Storage temperature range, T_{stg}	–65°C to 150°C

† Stresses beyond those listed under “absolute maximum ratings” may cause permanent damage to the device. These are stress ratings only, and functional operation of the device at these or any other conditions beyond those indicated under “recommended operating conditions” is not implied. Exposure to absolute-maximum-rated conditions for extended periods may affect device reliability.

- NOTES:
1. The input and output voltage ratings may be exceeded if the input and output current ratings are observed.
 2. This value is limited to 5.5 V maximum.
 3. The package thermal impedance is calculated in accordance with JESD 51-7.

SN54LV157A, SN74LV157A QUADRUPLE 2-LINE TO 1-LINE DATA SELECTORS/MULTIPLEXERS

SCLS397D – APRIL 1998 – REVISED JULY 2003

recommended operating conditions (see Note 4)

		SN54LV157A		SN74LV157A		UNIT	
		MIN	MAX	MIN	MAX		
V _{CC}	Supply voltage	2	5.5	2	5.5	V	
V _{IH}	High-level input voltage	V _{CC} = 2 V	1.5	1.5		V	
		V _{CC} = 2.3 V to 2.7 V	V _{CC} × 0.7	V _{CC} × 0.7			
		V _{CC} = 3 V to 3.6 V	V _{CC} × 0.7	V _{CC} × 0.7			
		V _{CC} = 4.5 V to 5.5 V	V _{CC} × 0.7	V _{CC} × 0.7			
V _{IL}	Low-level input voltage	V _{CC} = 2 V		0.5	0.5	V	
		V _{CC} = 2.3 V to 2.7 V	V _{CC} × 0.3	V _{CC} × 0.3			
		V _{CC} = 3 V to 3.6 V	V _{CC} × 0.3	V _{CC} × 0.3			
		V _{CC} = 4.5 V to 5.5 V	V _{CC} × 0.3	V _{CC} × 0.3			
V _I	Input voltage	0	5.5	0	5.5	V	
V _O	Output voltage	0	V _{CC}	0	V _{CC}	V	
I _{OH}	High-level output current	V _{CC} = 2 V		-50	-50	μA	
		V _{CC} = 2.3 V to 2.7 V		-2	-2	mA	
		V _{CC} = 3 V to 3.6 V		-6	-6		
		V _{CC} = 4.5 V to 5.5 V		-12	-12		
I _{OL}	Low-level output current	V _{CC} = 2 V		50	50	μA	
		V _{CC} = 2.3 V to 2.7 V		2	2	mA	
		V _{CC} = 3 V to 3.6 V		6	6		
		V _{CC} = 4.5 V to 5.5 V		12	12		
Δt/Δv	Input transition rise or fall rate	V _{CC} = 2.3 V to 2.7 V		200	0	200	ns/V
		V _{CC} = 3 V to 3.6 V		100	0	100	
		V _{CC} = 4.5 V to 5.5 V		20	0	20	
T _A	Operating free-air temperature	-55	125	-40	85	°C	

NOTE 4: All unused inputs of the device must be held at V_{CC} or GND to ensure proper device operation. Refer to the TI application report, *Implications of Slow or Floating CMOS Inputs*, literature number SCBA004.

electrical characteristics over recommended operating free-air temperature range (unless otherwise noted)

PARAMETER	TEST CONDITIONS	V _{CC}	SN54LV157A			SN74LV157A			UNIT
			MIN	TYP	MAX	MIN	TYP	MAX	
V _{OH}	I _{OH} = -50 μA	2 V to 5.5 V	V _{CC} -0.1			V _{CC} -0.1			V
	I _{OH} = -2 mA	2.3 V	2			2			
	I _{OH} = -6 mA	3 V	2.48			2.48			
	I _{OH} = -12 mA	4.5 V	3.8			3.8			
V _{OL}	I _{OL} = 50 μA	2 V to 5.5 V	0.1			0.1			V
	I _{OL} = 2 mA	2.3 V	0.4			0.4			
	I _{OL} = 6 mA	3 V	0.44			0.44			
	I _{OL} = 12 mA	4.5 V	0.55			0.55			
I _I	V _I = 5.5 V or GND	0 to 5.5 V	±1			±1			μA
I _{CC}	V _I = V _{CC} or GND, I _O = 0	5.5 V	20			20			μA
I _{off}	V _I or V _O = 0 to 5.5 V	0	5			5			μA
C _i	V _I = V _{CC} or GND	3.3 V	1.7			1.7			pF

PRODUCT PREVIEW information concerns products in the formative or design phase of development. Characteristic data and other specifications are design goals. Texas Instruments reserves the right to change or discontinue these products without notice.



SN54LV157A, SN74LV157A QUADRUPLE 2-LINE TO 1-LINE DATA SELECTORS/MULTIPLEXERS

SCLS397D – APRIL 1998 – REVISED JULY 2003

**switching characteristics over recommended operating free-air temperature range,
V_{CC} = 2.5 V ± 0.2 V (unless otherwise noted) (see Figure 1)**

PARAMETER	FROM (INPUT)	TO (OUTPUT)	LOAD CAPACITANCE	T _A = 25°C			SN54LV157A		SN74LV157A		UNIT
				MIN	TYP	MAX	MIN	MAX	MIN	MAX	
t _{pd}	A or B	Y	C _L = 15 pF	7.4*	15.9*	1*	19.5*	1	19.5	ns	
	$\overline{A/B}$	Y		7.9*	19.4*	1*	23.5*	1	23.5		
	\overline{G}	Y		7.8*	19.8*	1*	24*	1	24		
t _{pd}	A or B	Y	C _L = 50 pF	9.4	18.8	1	22	1	22	ns	
	$\overline{A/B}$	Y		10.8	22.3	1	26	1	26		
	\overline{G}	Y		9.6	22.7	1	26.5	1	26.5		

* On products compliant to MIL-PRF-38535, this parameter is not production tested.

**switching characteristics over recommended operating free-air temperature range,
V_{CC} = 3.3 V ± 0.3 V (unless otherwise noted) (see Figure 1)**

PARAMETER	FROM (INPUT)	TO (OUTPUT)	LOAD CAPACITANCE	T _A = 25°C			SN54LV157A		SN74LV157A		UNIT
				MIN	TYP	MAX	MIN	MAX	MIN	MAX	
t _{pd}	A or B	Y	C _L = 15 pF	5.2*	9.7*	1*	11.5*	1	11.5	ns	
	$\overline{A/B}$	Y		5.8*	13.2*	1*	15.5*	1	15.5		
	\overline{G}	Y		5.5*	13.6*	1*	16*	1	16		
t _{pd}	A or B	Y	C _L = 50 pF	6.7	13.2	1	15	1	15	ns	
	$\overline{A/B}$	Y		7.6	16.7	1	19	1	19		
	\overline{G}	Y		7	17.1	1	19.5	1	19.5		

* On products compliant to MIL-PRF-38535, this parameter is not production tested.

**switching characteristics over recommended operating free-air temperature range,
V_{CC} = 5 V ± 0.5 V (unless otherwise noted) (see Figure 1)**

PARAMETER	FROM (INPUT)	TO (OUTPUT)	LOAD CAPACITANCE	T _A = 25°C			SN54LV157A		SN74LV157A		UNIT
				MIN	TYP	MAX	MIN	MAX	MIN	MAX	
t _{pd}	A or B	Y	C _L = 15 pF	3.6*	6.4*	1*	7.5*	1	7.5	ns	
	$\overline{A/B}$	Y		4.1*	8.1*	1*	9.5*	1	9.5		
	\overline{G}	Y		3.8*	8.6*	1*	10*	1	10		
t _{pd}	A or B	Y	C _L = 50 pF	4.8	8.4	1	9.5	1	9.5	ns	
	$\overline{A/B}$	Y		5.4	10.1	1	11.5	1	11.5		
	\overline{G}	Y		5	10.6	1	12	1	12		

* On products compliant to MIL-PRF-38535, this parameter is not production tested.

noise characteristics, V_{CC} = 3.3 V, C_L = 50 pF, T_A = 25°C (see Note 5)

PARAMETER		SN74LV157A			UNIT
		MIN	TYP	MAX	
V _{OL(P)}	Quiet output, maximum dynamic V _{OL}	0.3	0.8		V
V _{OL(V)}	Quiet output, minimum dynamic V _{OL}	-0.1	-0.8		V
V _{OH(V)}	Quiet output, minimum dynamic V _{OH}	3.2			V
V _{IH(D)}	High-level dynamic input voltage	2.31			V
V _{IL(D)}	Low-level dynamic input voltage		0.99		V

NOTE 5: Characteristics are for surface-mount packages only.

PRODUCT PREVIEW information concerns products in the formative or design phase of development. Characteristic data and other specifications are design goals. Texas Instruments reserves the right to change or discontinue these products without notice.



POST OFFICE BOX 655303 • DALLAS, TEXAS 75265

SN54LV157A, SN74LV157A QUADRUPLE 2-LINE TO 1-LINE DATA SELECTORS/MULTIPLEXERS

SCLS397D – APRIL 1998 – REVISED JULY 2003

operating characteristics, $T_A = 25^\circ\text{C}$

PARAMETER		TEST CONDITIONS	V _{CC}	TYP	UNIT
C _{pd}	Power dissipation capacitance	C _L = 50 pF, f = 10 MHz	3.3 V	12.1	pF
			5 V	13.1	



SN54LV157A, SN74LV157A QUADRUPLE 2-LINE TO 1-LINE DATA SELECTORS/MULTIPLEXERS

SCLS397D – APRIL 1998 – REVISED JULY 2003

PARAMETER MEASUREMENT INFORMATION

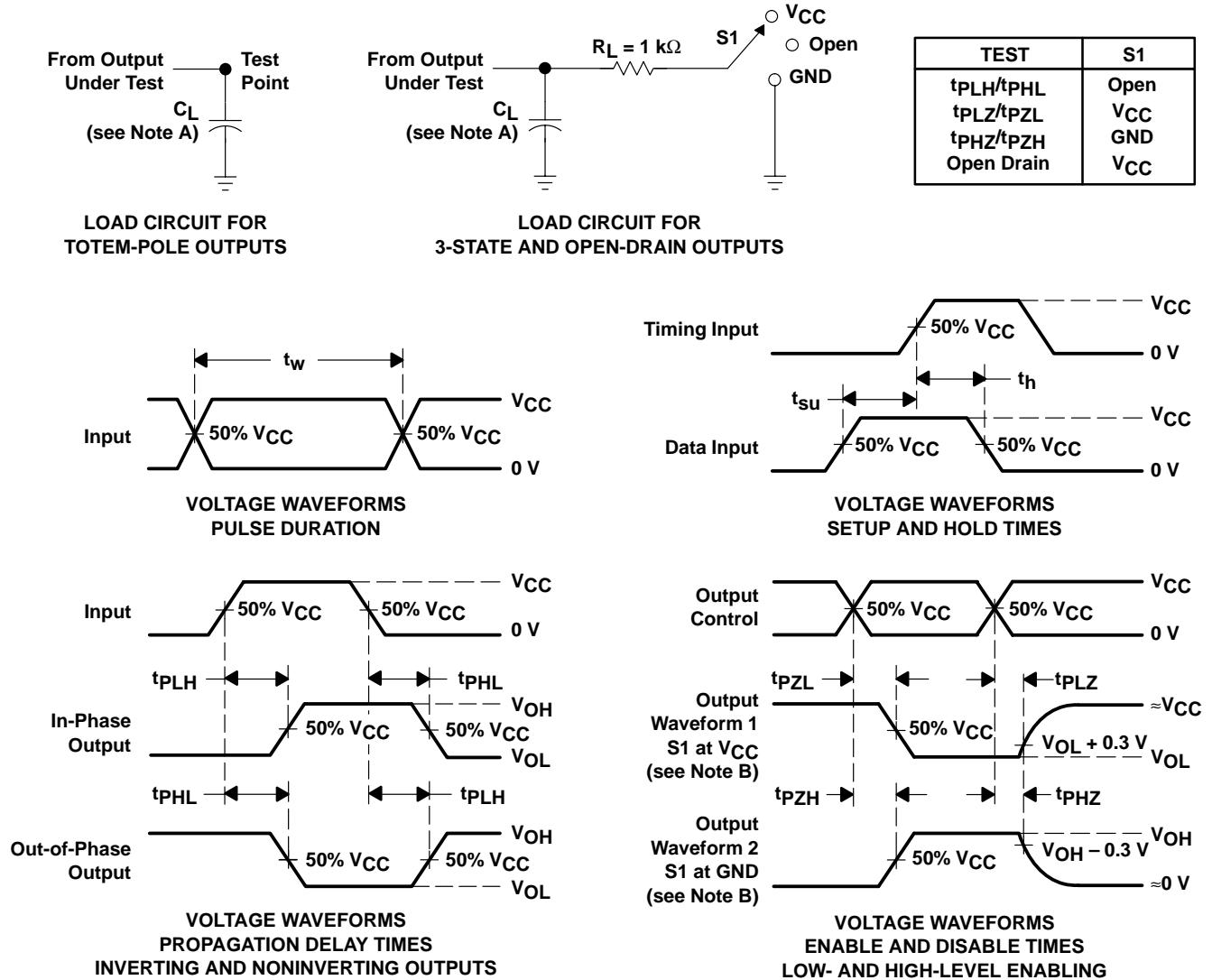



Input

t_w

$50\% V_{CC}$

$50\% V_{CC}$

V_{CC}

0 V

VOLTAGE WAVEFORMS PULSE DURATION



Timing Input

Data Input

t_{su}

t_h

$50\% V_{CC}$

$50\% V_{CC}$

V_{CC}

0 V

VOLTAGE WAVEFORMS SETUP AND HOLD TIMES



Input

In-Phase Output

Out-of-Phase Output

t_{PLH}

t_{PHL}

t_{PHL}

t_{PLH}

$50\% V_{CC}$

$50\% V_{CC}$

$50\% V_{CC}$

$50\% V_{CC}$

V_{CC}

0 V

V_{OH}

V_{OL}

V_{OH}

V_{OL}

VOLTAGE WAVEFORMS PROPAGATION DELAY TIMES INVERTING AND NONINVERTING OUTPUTS



Output Control

Output Waveform 1 S1 at V_{CC} (see Note B)

Output Waveform 2 S1 at GND (see Note B)

t_{PZL}

t_{PLZ}

t_{PZH}

t_{PHZ}

$50\% V_{CC}$

$50\% V_{CC}$

$50\% V_{CC}$

$50\% V_{CC}$

V_{CC}

0 V

$\approx V_{CC}$

$V_{OL} + 0.3\text{ V}$

V_{OL}

$V_{OH} - 0.3\text{ V}$

V_{OH}

$\approx 0\text{ V}$

VOLTAGE WAVEFORMS ENABLE AND DISABLE TIMES LOW- AND HIGH-LEVEL ENABLING

- NOTES:
- A. C_L includes probe and jig capacitance.
 - B. Waveform 1 is for an output with internal conditions such that the output is low except when disabled by the output control. Waveform 2 is for an output with internal conditions such that the output is high except when disabled by the output control.
 - C. All input pulses are supplied by generators having the following characteristics: $PRR \leq 1\text{ MHz}$, $Z_O = 50\ \Omega$, $t_r \leq 3\text{ ns}$, $t_f \leq 3\text{ ns}$.
 - D. The outputs are measured one at a time with one input transition per measurement.
 - E. t_{PLZ} and t_{PHZ} are the same as t_{dis} .
 - F. t_{PZL} and t_{PZH} are the same as t_{en} .
 - G. t_{PHL} and t_{PLH} are the same as t_{pd} .
 - H. All parameters and waveforms are not applicable to all devices.

Figure 1. Load Circuit and Voltage Waveforms

DGV (R-PDSO-G**)

PLASTIC SMALL-OUTLINE

24 PINS SHOWN



- NOTES: A. All linear dimensions are in millimeters.
 B. This drawing is subject to change without notice.
 C. Body dimensions do not include mold flash or protrusion, not to exceed 0,15 per side.
 D. Falls within JEDEC: 24/48 Pins – MO-153
 14/16/20/56 Pins – MO-194

D (R-PDSO-G16)

PLASTIC SMALL-OUTLINE PACKAGE



4040047-4/F 07/2004

- NOTES:
- A. All linear dimensions are in inches (millimeters).
 - B. This drawing is subject to change without notice.
 - C. Body dimensions do not include mold flash or protrusion not to exceed 0.006 (0,15).
 - D. Falls within JEDEC MS-012 variation AC.

MECHANICAL DATA

NS (R-PDSO-G**)

PLASTIC SMALL-OUTLINE PACKAGE

14-PINS SHOWN



- NOTES:
- All linear dimensions are in millimeters.
 - This drawing is subject to change without notice.
 - Body dimensions do not include mold flash or protrusion, not to exceed 0,15.

DB (R-PDSO-G**)

PLASTIC SMALL-OUTLINE

28 PINS SHOWN



- NOTES: A. All linear dimensions are in millimeters.
 B. This drawing is subject to change without notice.
 C. Body dimensions do not include mold flash or protrusion not to exceed 0,15.
 D. Falls within JEDEC MO-150

PW (R-PDSO-G**)

PLASTIC SMALL-OUTLINE PACKAGE

14 PINS SHOWN



4040064/F 01/97

- NOTES: A. All linear dimensions are in millimeters.
 B. This drawing is subject to change without notice.
 C. Body dimensions do not include mold flash or protrusion not to exceed 0,15.
 D. Falls within JEDEC MO-153

IMPORTANT NOTICE

Texas Instruments Incorporated and its subsidiaries (TI) reserve the right to make corrections, modifications, enhancements, improvements, and other changes to its products and services at any time and to discontinue any product or service without notice. Customers should obtain the latest relevant information before placing orders and should verify that such information is current and complete. All products are sold subject to TI's terms and conditions of sale supplied at the time of order acknowledgment.

TI warrants performance of its hardware products to the specifications applicable at the time of sale in accordance with TI's standard warranty. Testing and other quality control techniques are used to the extent TI deems necessary to support this warranty. Except where mandated by government requirements, testing of all parameters of each product is not necessarily performed.

TI assumes no liability for applications assistance or customer product design. Customers are responsible for their products and applications using TI components. To minimize the risks associated with customer products and applications, customers should provide adequate design and operating safeguards.

TI does not warrant or represent that any license, either express or implied, is granted under any TI patent right, copyright, mask work right, or other TI intellectual property right relating to any combination, machine, or process in which TI products or services are used. Information published by TI regarding third-party products or services does not constitute a license from TI to use such products or services or a warranty or endorsement thereof. Use of such information may require a license from a third party under the patents or other intellectual property of the third party, or a license from TI under the patents or other intellectual property of TI.

Reproduction of information in TI data books or data sheets is permissible only if reproduction is without alteration and is accompanied by all associated warranties, conditions, limitations, and notices. Reproduction of this information with alteration is an unfair and deceptive business practice. TI is not responsible or liable for such altered documentation.

Resale of TI products or services with statements different from or beyond the parameters stated by TI for that product or service voids all express and any implied warranties for the associated TI product or service and is an unfair and deceptive business practice. TI is not responsible or liable for any such statements.

Following are URLs where you can obtain information on other Texas Instruments products and application solutions:

Products		Applications	
Amplifiers	amplifier.ti.com	Audio	www.ti.com/audio
Data Converters	dataconverter.ti.com	Automotive	www.ti.com/automotive
DSP	dsp.ti.com	Broadband	www.ti.com/broadband
Interface	interface.ti.com	Digital Control	www.ti.com/digitalcontrol
Logic	logic.ti.com	Military	www.ti.com/military
Power Mgmt	power.ti.com	Optical Networking	www.ti.com/opticalnetwork
Microcontrollers	microcontroller.ti.com	Security	www.ti.com/security
		Telephony	www.ti.com/telephony
		Video & Imaging	www.ti.com/video
		Wireless	www.ti.com/wireless

Mailing Address: Texas Instruments
Post Office Box 655303 Dallas, Texas 75265