

SN54LV139A, SN74LV139A DUAL 2-LINE TO 4-LINE DECODERS/DEMULTIPLEXERS

SCLS396G – APRIL 1998 – REVISED JULY 2003

- 2-V to 5.5-V V_{CC} Operation
- Max t_{pd} of 7.5 ns at 5 V
- Support Mixed-Mode Voltage Operation on All Ports
- Designed Specifically for High-Speed Memory Decoders and Data-Transmission Systems
- Incorporate Two Enable Inputs to Simplify Cascading and/or Data Reception
- I_{off} Supports Partial-Power-Down Mode Operation
- Latch-Up Performance Exceeds 250 mA Per JESD 17
- ESD Protection Exceeds JESD 22
 - 2000-V Human-Body Model (A114-A)
 - 200-V Machine Model (A115-A)
 - 1000-V Charged-Device Model (C101)

SN54LV139A ... J OR W PACKAGE
SN74LV139A ... D, DB, DGV, NS,
OR PW PACKAGE
(TOP VIEW)

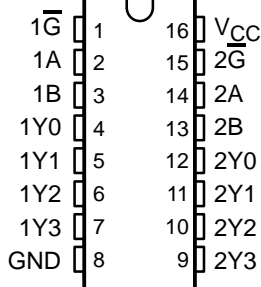

SN74LV139A ... RGY PACKAGE
(TOP VIEW)

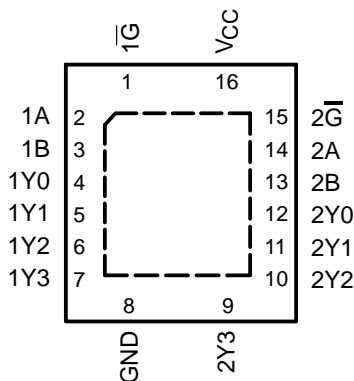

SN54LV139A ... FK PACKAGE
(TOP VIEW)

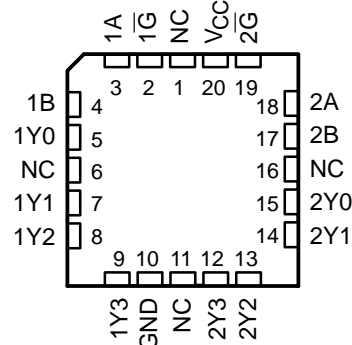

NC – No internal connection

description/ordering information

The 'LV139A devices are dual 2-line to 4-line decoders/demultiplexers designed for 2-V to 5.5-V V_{CC} operation.

ORDERING INFORMATION

T_A	PACKAGE†		ORDERABLE PART NUMBER	TOP-SIDE MARKING
–40°C to 85°C	QFN – RGY	Reel of 1000	SN74LV139ARGYR	LV139A
	SOIC – D	Tube of 40	SN74LV139AD	LV139A
		Reel of 2500	SN74LV139ADR	
	SOP – NS	Reel of 2000	SN74LV139ANSR	74LV139A
	SSOP – DB	Reel of 2000	SN74LV139ADBR	LV139A
	TSSOP – PW	Tube of 90	SN74LV139APW	LV139A
		Reel of 2000	SN74LV139APWR	
Reel of 250		SN74LV139APWT		
TVSOP – DGV	Reel of 2000	SN74LV139ADGVR	LV139A	
–55°C to 125°C	CDIP – J	Tube of 25	SNJ54LV139AJ	SNJ54LV139AJ
	CFP – W	Tube of 150	SNJ54LV139AW	SNJ54LV139AW
	LCCC – FK	Tube of 55	SNJ54LV139AFK	SNJ54LV139AFK

† Package drawings, standard packing quantities, thermal data, symbolization, and PCB design guidelines are available at www.ti.com/sc/package.



Please be aware that an important notice concerning availability, standard warranty, and use in critical applications of Texas Instruments semiconductor products and disclaimers thereto appears at the end of this data sheet.

UNLESS OTHERWISE NOTED this document contains PRODUCTION DATA information current as of publication date. Products conform to specifications per the terms of Texas Instruments standard warranty. Production processing does not necessarily include testing of all parameters.

**TEXAS
INSTRUMENTS**

POST OFFICE BOX 655303 • DALLAS, TEXAS 75265

Copyright © 2003, Texas Instruments Incorporated

SN54LV139A, SN74LV139A DUAL 2-LINE TO 4-LINE DECODERS/DEMULTIPLEXERS

SCLS396G – APRIL 1998 – REVISED JULY 2003

description/ordering information(continued)

These devices are designed for high-performance memory-decoding or data-routing applications requiring very short propagation delay times. In high-performance memory systems, these decoders can minimize the effects of system decoding. When employed with high-speed memories utilizing a fast enable circuit, the delay time of these decoders and the enable time of the memory usually are less than the typical access time of the memory. This means that the effective system delay introduced by the decoders is negligible.

The 'LV139A devices comprise two individual 2-line to 4-line decoders in a single package. The active-low enable (\overline{G}) input can be used as a data line in demultiplexing applications. These decoders/demultiplexers feature fully buffered inputs, each of which represents only one normalized load to its driving circuit.

These devices are fully specified for partial-power-down applications using I_{off} . The I_{off} circuitry disables the outputs, preventing damaging current backflow through the devices when they are powered down.

FUNCTION TABLE

INPUTS			OUTPUTS			
\overline{G}	SELECT		Y0	Y1	Y2	Y3
	B	A				
H	X	X	H	H	H	H
L	L	L	L	H	H	H
L	L	H	H	L	H	H
L	H	L	H	H	L	H
L	H	H	H	H	H	L



POST OFFICE BOX 655303 • DALLAS, TEXAS 75265

SN54LV139A, SN74LV139A DUAL 2-LINE TO 4-LINE DECODERS/DEMULTIPLEXERS

SCLS396G – APRIL 1998 – REVISED JULY 2003

logic diagram (positive logic)

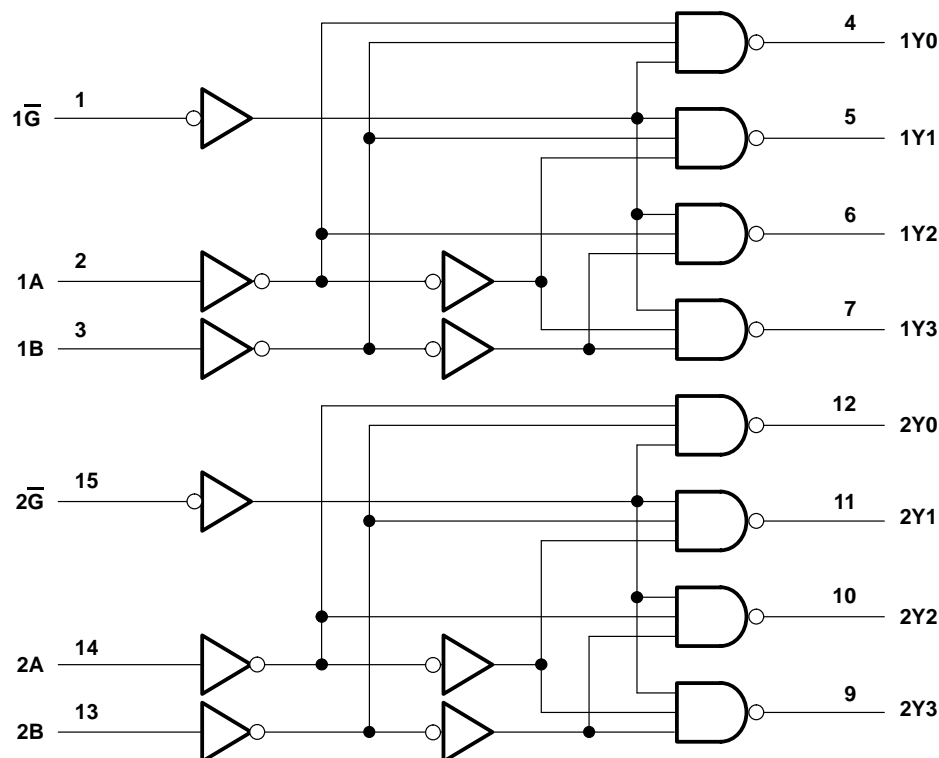

Pin numbers shown are for the D, DB, DGV, J, NS, PW, RGY, and W packages.

absolute maximum ratings over operating free-air temperature range (unless otherwise noted)[†]

Supply voltage range, V_{CC}	-0.5 V to 7 V
Input voltage range, V_I (see Note 1)	-0.5 V to 7 V
Voltage range applied to any output in the high-impedance or power-off state, V_O (see Note 1)	-0.5 V to 7 V
Output voltage range, V_O (see Notes 1 and 2)	-0.5 V to $V_{CC} + 0.5$ V
Input clamp current, I_{IK} ($V_I < 0$)	-20 mA
Output clamp current, I_{OK} ($V_O < 0$ or $V_O > V_{CC}$)	± 50 mA
Continuous output current, I_O ($V_O = 0$ to V_{CC})	± 25 mA
Continuous current through V_{CC} or GND	± 50 mA
Package thermal impedance, θ_{JA} (see Note 3): D package	73°C/W
(see Note 3): DB package	82°C/W
(see Note 3): DGV package	120°C/W
(see Note 3): NS package	64°C/W
(see Note 3): PW package	108°C/W
(see Note 4): RGY package	39°C/W
Storage temperature range, T_{stg}	-65°C to 150°C

[†] Stresses beyond those listed under "absolute maximum ratings" may cause permanent damage to the device. These are stress ratings only, and functional operation of the device at these or any other conditions beyond those indicated under "recommended operating conditions" is not implied. Exposure to absolute-maximum-rated conditions for extended periods may affect device reliability.

- NOTES:
1. The input and output voltage ratings may be exceeded if the input and output current ratings are observed.
 2. This value is limited to 5.5 V maximum.
 3. The package thermal impedance is calculated in accordance with JESD 51-7.
 4. The package thermal impedance is calculated in accordance with JESD 51-5.



SN54LV139A, SN74LV139A DUAL 2-LINE TO 4-LINE DECODERS/DEMULTIPLEXERS

SCLS396G – APRIL 1998 – REVISED JULY 2003

recommended operating conditions (see Note 5)

		SN54LV139A		SN74LV139A		UNIT
		MIN	MAX	MIN	MAX	
V_{CC}	Supply voltage	2	5.5	2	5.5	V
V_{IH}	High-level input voltage	$V_{CC} = 2\text{ V}$		1.5		V
		$V_{CC} = 2.3\text{ V to }2.7\text{ V}$		$V_{CC} \times 0.7$		
		$V_{CC} = 3\text{ V to }3.6\text{ V}$		$V_{CC} \times 0.7$		
		$V_{CC} = 4.5\text{ V to }5.5\text{ V}$		$V_{CC} \times 0.7$		
V_{IL}	Low-level input voltage	$V_{CC} = 2\text{ V}$		0.5		V
		$V_{CC} = 2.3\text{ V to }2.7\text{ V}$		$V_{CC} \times 0.3$		
		$V_{CC} = 3\text{ V to }3.6\text{ V}$		$V_{CC} \times 0.3$		
		$V_{CC} = 4.5\text{ V to }5.5\text{ V}$		$V_{CC} \times 0.3$		
V_I	Input voltage	0	5.5	0	5.5	V
V_O	Output voltage	0	V_{CC}	0	V_{CC}	V
I_{OH}	High-level output current	$V_{CC} = 2\text{ V}$		-50		μA
		$V_{CC} = 2.3\text{ V to }2.7\text{ V}$		-2		mA
		$V_{CC} = 3\text{ V to }3.6\text{ V}$		-6		
		$V_{CC} = 4.5\text{ V to }5.5\text{ V}$		-12		
I_{OL}	Low-level output current	$V_{CC} = 2\text{ V}$		50		μA
		$V_{CC} = 2.3\text{ V to }2.7\text{ V}$		2		mA
		$V_{CC} = 3\text{ V to }3.6\text{ V}$		6		
		$V_{CC} = 4.5\text{ V to }5.5\text{ V}$		12		
$\Delta t/\Delta v$	Input transition rise or fall rate	$V_{CC} = 2.3\text{ V to }2.7\text{ V}$		200		ns/V
		$V_{CC} = 3\text{ V to }3.6\text{ V}$		100		
		$V_{CC} = 4.5\text{ V to }5.5\text{ V}$		20		
T_A	Operating free-air temperature	-55	125	-40	85	$^{\circ}\text{C}$

NOTE 5: All unused inputs of the device must be held at V_{CC} or GND to ensure proper device operation. Refer to the TI application report, *Implications of Slow or Floating CMOS Inputs*, literature number SCBA004.

electrical characteristics over recommended operating free-air temperature range (unless otherwise noted)

PARAMETER	TEST CONDITIONS	V_{CC}	SN54LV139A			SN74LV139A			UNIT
			MIN	TYP	MAX	MIN	TYP	MAX	
V_{OH}	$I_{OH} = -50\ \mu\text{A}$	2 V to 5.5 V	$V_{CC}-0.1$			$V_{CC}-0.1$			V
	$I_{OH} = -2\ \text{mA}$	2.3 V	2			2			
	$I_{OH} = -6\ \text{mA}$	3 V	2.48			2.48			
	$I_{OH} = -12\ \text{mA}$	4.5 V	3.8			3.8			
V_{OL}	$I_{OL} = 50\ \mu\text{A}$	2 V to 5.5 V	0.1			0.1			V
	$I_{OL} = 2\ \text{mA}$	2.3 V	0.4			0.4			
	$I_{OL} = 6\ \text{mA}$	3 V	0.44			0.44			
	$I_{OL} = 12\ \text{mA}$	4.5 V	0.55			0.55			
I_I	$V_I = 5.5\text{ V or GND}$	0 to 5.5 V	± 1			± 1			μA
I_{CC}	$V_I = V_{CC}\text{ or GND, } I_O = 0$	5.5 V	20			20			μA
I_{off}	$V_I\text{ or }V_O = 0\text{ to }5.5\text{ V}$	0	5			5			μA
C_i	$V_I = V_{CC}\text{ or GND}$	3.3 V	1.9			1.9			pF

PRODUCT PREVIEW information concerns products in the formative or design phase of development. Characteristic data and other specifications are design goals. Texas Instruments reserves the right to change or discontinue these products without notice.



POST OFFICE BOX 655303 • DALLAS, TEXAS 75265

SN54LV139A, SN74LV139A DUAL 2-LINE TO 4-LINE DECODERS/DEMULTIPLEXERS

SCLS396G – APRIL 1998 – REVISED JULY 2003

switching characteristics over recommended operating free-air temperature range, $V_{CC} = 2.5\text{ V} \pm 0.2\text{ V}$ (unless otherwise noted) (see Figure 1)

PARAMETER	FROM (INPUT)	TO (OUTPUT)	LOAD CAPACITANCE	$T_A = 25^\circ\text{C}$			SN54LV139A		SN74LV139A		UNIT
				MIN	TYP	MAX	MIN	MAX	MIN	MAX	
t_{pd}	A or B	Y	$C_L = 15\text{ pF}$	7.7*	17.6*	1*	21*	1	21	ns	
	\overline{G}	Y		7.4*	15.8*	1*	19*	1	19		
t_{pd}	A or B	Y	$C_L = 50\text{ pF}$	10.2	22.5	1	26.5	1	26.5	ns	
	\overline{G}	Y		9.9	20.2	1	24	1	24		

* On products compliant to MIL-PRF-38535, this parameter is not production tested.

switching characteristics over recommended operating free-air temperature range, $V_{CC} = 3.3\text{ V} \pm 0.3\text{ V}$ (unless otherwise noted) (see Figure 1)

PARAMETER	FROM (INPUT)	TO (OUTPUT)	LOAD CAPACITANCE	$T_A = 25^\circ\text{C}$			SN54LV139A		SN74LV139A		UNIT
				MIN	TYP	MAX	MIN	MAX	MIN	MAX	
t_{pd}	A or B	Y	$C_L = 15\text{ pF}$	5.3*	11*	1*	13*	1	13	ns	
	\overline{G}	Y		5.1*	9.2*	1*	11*	1	11		
t_{pd}	A or B	Y	$C_L = 50\text{ pF}$	7.3	14.5	1	16.5	1	16.5	ns	
	\overline{G}	Y		7	12.7	1	14.5	1	14.5		

* On products compliant to MIL-PRF-38535, this parameter is not production tested.

switching characteristics over recommended operating free-air temperature range, $V_{CC} = 5\text{ V} \pm 0.5\text{ V}$ (unless otherwise noted) (see Figure 1)

PARAMETER	FROM (INPUT)	TO (OUTPUT)	LOAD CAPACITANCE	$T_A = 25^\circ\text{C}$			SN54LV139A		SN74LV139A		UNIT
				MIN	TYP	MAX	MIN	MAX	MIN	MAX	
t_{pd}	A or B	Y	$C_L = 15\text{ pF}$	3.7*	7.2*	1*	8.5*	1	8.5	ns	
	\overline{G}	Y		3.5*	6.3*	1*	7.5*	1	7.5		
t_{pd}	A or B	Y	$C_L = 50\text{ pF}$	5.2	9.2	1	10.5	1	10.5	ns	
	\overline{G}	Y		4.9	8.3	1	9.5	1	9.5		

* On products compliant to MIL-PRF-38535, this parameter is not production tested.

operating characteristics, $T_A = 25^\circ\text{C}$

PARAMETER	TEST CONDITIONS	V_{CC}	TYP	UNIT
C_{pd} Power dissipation capacitance	$C_L = 50\text{ pF}$, $f = 10\text{ MHz}$	3.3 V	17.3	pF
		5 V	18.2	

PRODUCT PREVIEW information concerns products in the formative or design phase of development. Characteristic data and other specifications are design goals. Texas Instruments reserves the right to change or discontinue these products without notice.



POST OFFICE BOX 655303 • DALLAS, TEXAS 75265

SN54LV139A, SN74LV139A DUAL 2-LINE TO 4-LINE DECODERS/DEMULTIPLEXERS

SCLS396G – APRIL 1998 – REVISED JULY 2003

PARAMETER MEASUREMENT INFORMATION

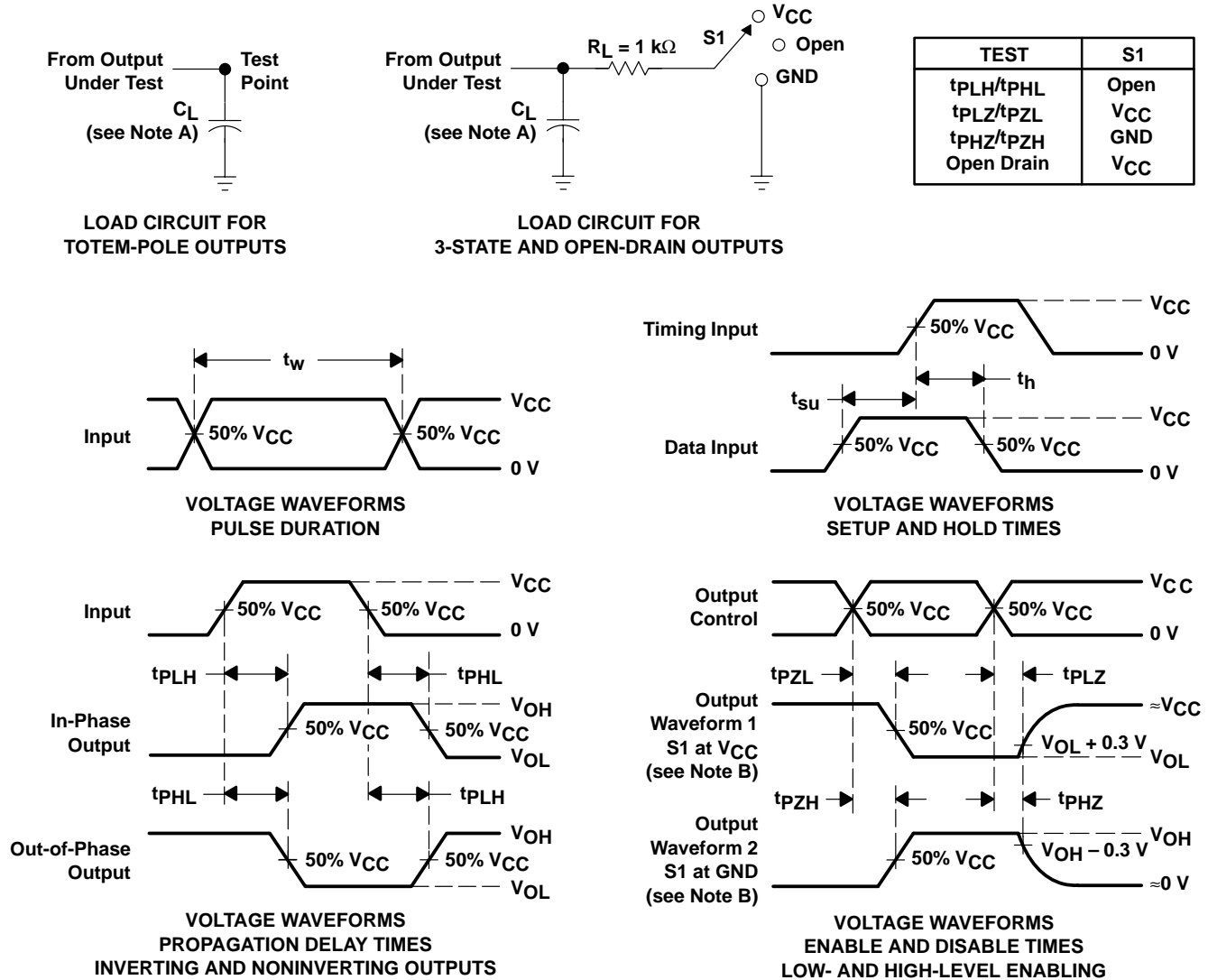

- NOTES:
- A. C_L includes probe and jig capacitance.
 - B. Waveform 1 is for an output with internal conditions such that the output is low except when disabled by the output control. Waveform 2 is for an output with internal conditions such that the output is high except when disabled by the output control.
 - C. All input pulses are supplied by generators having the following characteristics: $PRR \leq 1\text{ MHz}$, $Z_O = 50\ \Omega$, $t_r \leq 3\text{ ns}$, $t_f \leq 3\text{ ns}$.
 - D. The outputs are measured one at a time with one input transition per measurement.
 - E. t_{PLZ} and t_{PHZ} are the same as t_{dis} .
 - F. t_{PZL} and t_{PZH} are the same as t_{en} .
 - G. t_{PHL} and t_{PLH} are the same as t_{pd} .
 - H. All parameters and waveforms are not applicable to all devices.

Figure 1. Load Circuit and Voltage Waveforms

DGV (R-PDSO-G**)

PLASTIC SMALL-OUTLINE

24 PINS SHOWN



- NOTES: A. All linear dimensions are in millimeters.
 B. This drawing is subject to change without notice.
 C. Body dimensions do not include mold flash or protrusion, not to exceed 0,15 per side.
 D. Falls within JEDEC: 24/48 Pins – MO-153
 14/16/20/56 Pins – MO-194

D (R-PDSO-G16)

PLASTIC SMALL-OUTLINE PACKAGE

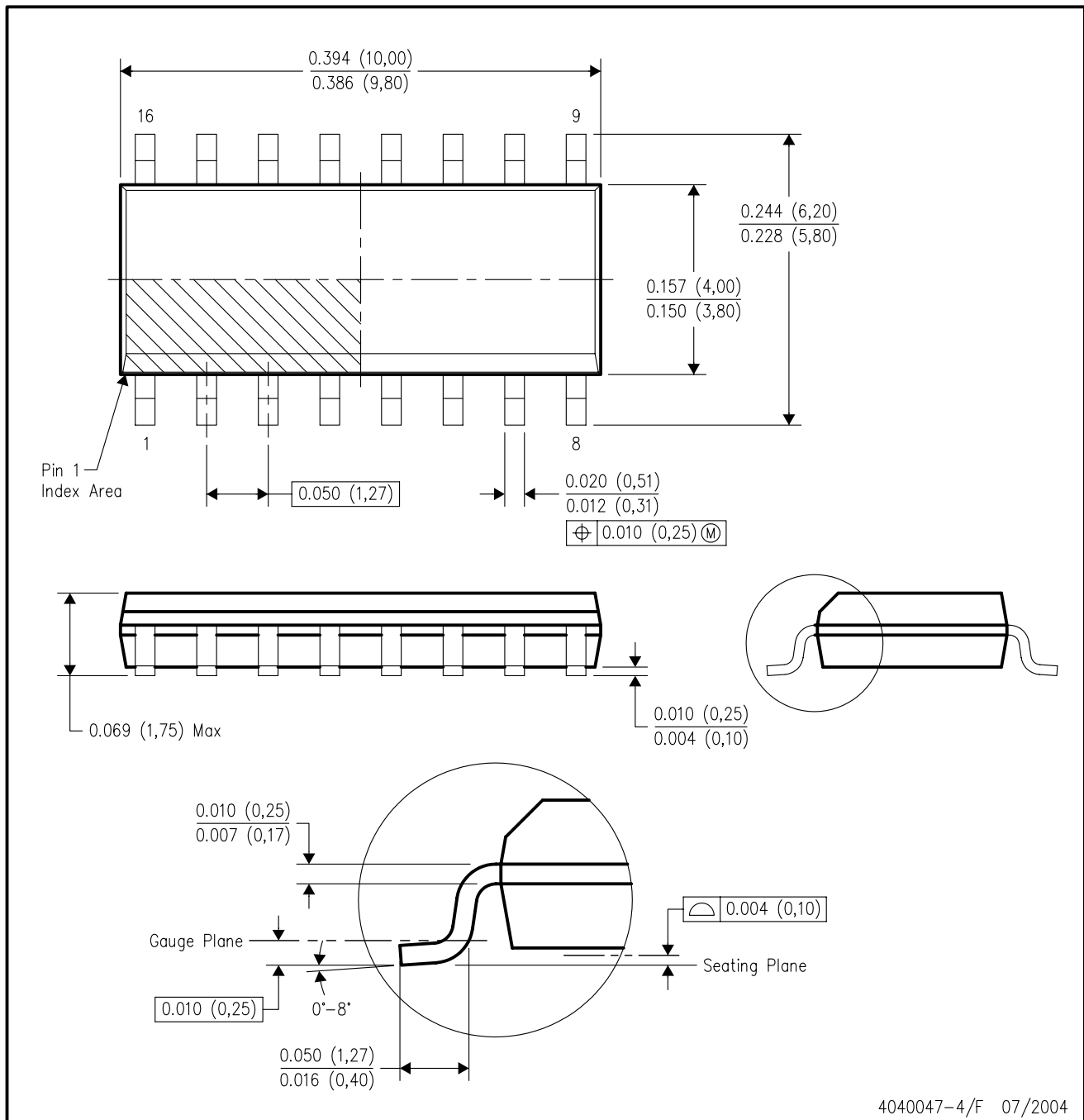

- NOTES:
- A. All linear dimensions are in inches (millimeters).
 - B. This drawing is subject to change without notice.
 - C. Body dimensions do not include mold flash or protrusion not to exceed 0.006 (0,15).
 - D. Falls within JEDEC MS-012 variation AC.

MECHANICAL DATA

NS (R-PDSO-G**)

PLASTIC SMALL-OUTLINE PACKAGE

14-PINS SHOWN



- NOTES:
- A. All linear dimensions are in millimeters.
 - B. This drawing is subject to change without notice.
 - C. Body dimensions do not include mold flash or protrusion, not to exceed 0,15.

DB (R-PDSO-G**)

PLASTIC SMALL-OUTLINE

28 PINS SHOWN



- NOTES: A. All linear dimensions are in millimeters.
 B. This drawing is subject to change without notice.
 C. Body dimensions do not include mold flash or protrusion not to exceed 0,15.
 D. Falls within JEDEC MO-150

PW (R-PDSO-G**)

PLASTIC SMALL-OUTLINE PACKAGE

14 PINS SHOWN



4040064/F 01/97

- NOTES: A. All linear dimensions are in millimeters.
 B. This drawing is subject to change without notice.
 C. Body dimensions do not include mold flash or protrusion not to exceed 0,15.
 D. Falls within JEDEC MO-153

IMPORTANT NOTICE

Texas Instruments Incorporated and its subsidiaries (TI) reserve the right to make corrections, modifications, enhancements, improvements, and other changes to its products and services at any time and to discontinue any product or service without notice. Customers should obtain the latest relevant information before placing orders and should verify that such information is current and complete. All products are sold subject to TI's terms and conditions of sale supplied at the time of order acknowledgment.

TI warrants performance of its hardware products to the specifications applicable at the time of sale in accordance with TI's standard warranty. Testing and other quality control techniques are used to the extent TI deems necessary to support this warranty. Except where mandated by government requirements, testing of all parameters of each product is not necessarily performed.

TI assumes no liability for applications assistance or customer product design. Customers are responsible for their products and applications using TI components. To minimize the risks associated with customer products and applications, customers should provide adequate design and operating safeguards.

TI does not warrant or represent that any license, either express or implied, is granted under any TI patent right, copyright, mask work right, or other TI intellectual property right relating to any combination, machine, or process in which TI products or services are used. Information published by TI regarding third-party products or services does not constitute a license from TI to use such products or services or a warranty or endorsement thereof. Use of such information may require a license from a third party under the patents or other intellectual property of the third party, or a license from TI under the patents or other intellectual property of TI.

Reproduction of information in TI data books or data sheets is permissible only if reproduction is without alteration and is accompanied by all associated warranties, conditions, limitations, and notices. Reproduction of this information with alteration is an unfair and deceptive business practice. TI is not responsible or liable for such altered documentation.

Resale of TI products or services with statements different from or beyond the parameters stated by TI for that product or service voids all express and any implied warranties for the associated TI product or service and is an unfair and deceptive business practice. TI is not responsible or liable for any such statements.

Following are URLs where you can obtain information on other Texas Instruments products and application solutions:

Products		Applications	
Amplifiers	amplifier.ti.com	Audio	www.ti.com/audio
Data Converters	dataconverter.ti.com	Automotive	www.ti.com/automotive
DSP	dsp.ti.com	Broadband	www.ti.com/broadband
Interface	interface.ti.com	Digital Control	www.ti.com/digitalcontrol
Logic	logic.ti.com	Military	www.ti.com/military
Power Mgmt	power.ti.com	Optical Networking	www.ti.com/opticalnetwork
Microcontrollers	microcontroller.ti.com	Security	www.ti.com/security
		Telephony	www.ti.com/telephony
		Video & Imaging	www.ti.com/video
		Wireless	www.ti.com/wireless

Mailing Address: Texas Instruments
Post Office Box 655303 Dallas, Texas 75265