

# SN54LS673, SN54LS674, SN74LS673, SN74LS674 16-BIT SHIFT REGISTERS

SDLS195 – MARCH 1985 – REVISED MARCH 1988

## 'LS673

- 16-Bit Serial-In, Serial-Out Shift Register with 16-Bit Parallel-Out Storage Register
- Performs Serial-to-Parallel Conversion

## 'LS674

- 16-Bit Parallel-In, Serial-Out Shift Register
- Performs Parallel-to-Serial Conversion

## description

### SN54LS673, SN74LS673

The 'LS673 is a 16-bit shift register and a 16-bit storage register in a single 24-pin package. A three-state input/output (SER/Q15) port to the shift register allows serial entry and/or reading of data. The storage register is connected in a parallel data loop with the shift register and may be asynchronously cleared by taking the store-clear input low. The storage register may be parallel loaded with shift-register data to provide shift-register status via the parallel outputs. The shift register can be parallel loaded with the storage-register data upon command.

A high logic level at the chip-level ( $\overline{CS}$ ) input disables both the shift-register clock and the storage register clock and places SER/Q15 in the high-impedance state. The store-clear function is not disabled by the chip select.

Caution must be exercised to prevent false clocking of either the shift register or the storage register via the chip-select input. The shift clock should be low during the low-to-high transition of chip select and the store clock should be low during the high-to-low transition of chip select.

### SN54LS674, SN74LS674

The 'LS674 is a 16-bit parallel-in, serial-out shift register. A three-state input/output (SER/Q15) port provides access for entering a serial data or reading the shift-register word in a recirculating loop.

The device has four basic modes of operation:

- 1) Hold (do nothing)
- 2) Write (serially via input/output)
- 3) Read (serially)
- 4) Load (parallel via data inputs)

Low-to-high-level changes at the chip select input should be made only when the clock input is low to prevent false clocking.

### SN54LS673 . . . J OR W PACKAGE SN74LS673 . . . DW OR N PACKAGE (TOP VIEW)

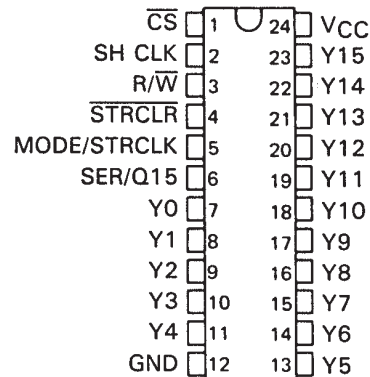

### SN54LS673 . . . FK PACKAGE (TOP VIEW)

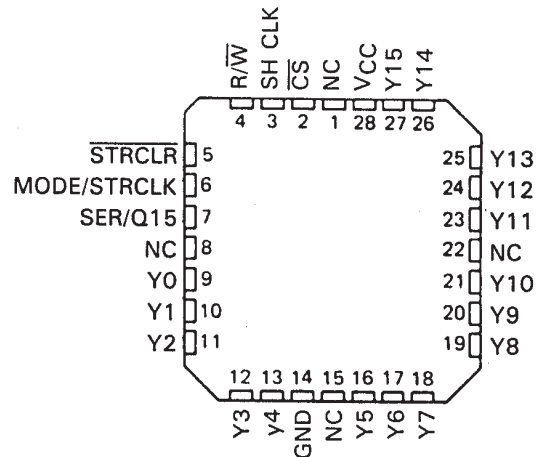

NC—No internal connection

# SN54LS673, SN54LS674, SN74LS673, SN74LS674 16-BIT SHIFT REGISTERS

SDLS195 – MARCH 1985 – REVISED MARCH 1988

SN54LS674 . . . J OR W PACKAGE  
SN74LS674 . . . DW OR N PACKAGE  
(TOP VIEW)

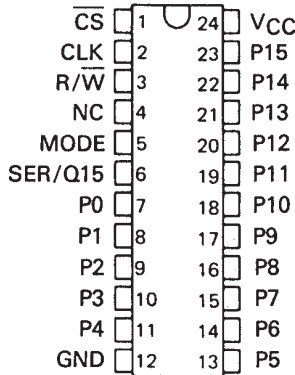

SN54LS674 . . . FK PACKAGE  
(TOP VIEW)

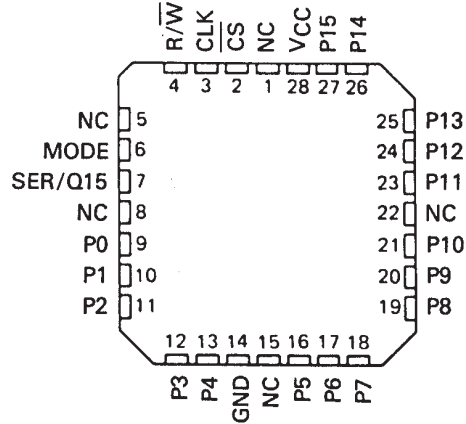

'LS673  
FUNCTION TABLE

INPUTS					SER/ Q15	SHIFT REGISTER FUNCTIONS				STORAGE REGISTER FUNCTIONS	
CS	R/W	SH CLK	STRCLR	MODE/ STRCLK		SHIFT	READ FROM SERIAL OUTPUT	WRITE INTO SERIAL INPUT	PARALLEL LOAD	CLEAR	LOAD
H	X	X	X	X	Z	NO	NO	NO	NO		NO
X	X	X	L	X						YES	
L	L	↓	X	X	Z	YES	NO	YES	NO		
L	H	X	X	X	Q15		YES	NO			NO
L	H	↓	X	L	Q14n	YES	YES	NO	NO		NO
L	H	↓	L	H	L	NO	YES		YES	YES	NO
L	H	↓	H	H	Y15n	NO	YES		YES	NO	NO
L	L	X	H	↑	Z		NO		NO	NO	YES

'LS674 FUNCTION TABLE

INPUTS				SER/ Q15	OPERATION
CS	R/W	MODE	CLK		
H	X	X	X	Z	Do nothing
L	L	X	↓	Z	Shift and write (serial load)
L	H	L	↓	Q14n	Shift and read
L	H	H	↓	P15	Parallel load

H = high level (steady state)  
L = low level (steady state)  
↑ = transition from low to high level  
↓ = transition from high to low level  
X = irrelevant (any input including transitions)  
Z = high impedance, input mode  
Q14n = content of 14th bit of the shift register before the most recent ↓ transition of the clock.  
Q15 = present content of 15th bit of the shift register  
Y15n = content of the 15th bit of the storage register before the most recent ↓ transition of the clock.  
P15 = level of input P15

# SN54LS673, SN54LS674, SN74LS673, SN74LS674 16-BIT SHIFT REGISTERS

SDLS195 – MARCH 1985 – REVISED MARCH 1988

logic symbols†

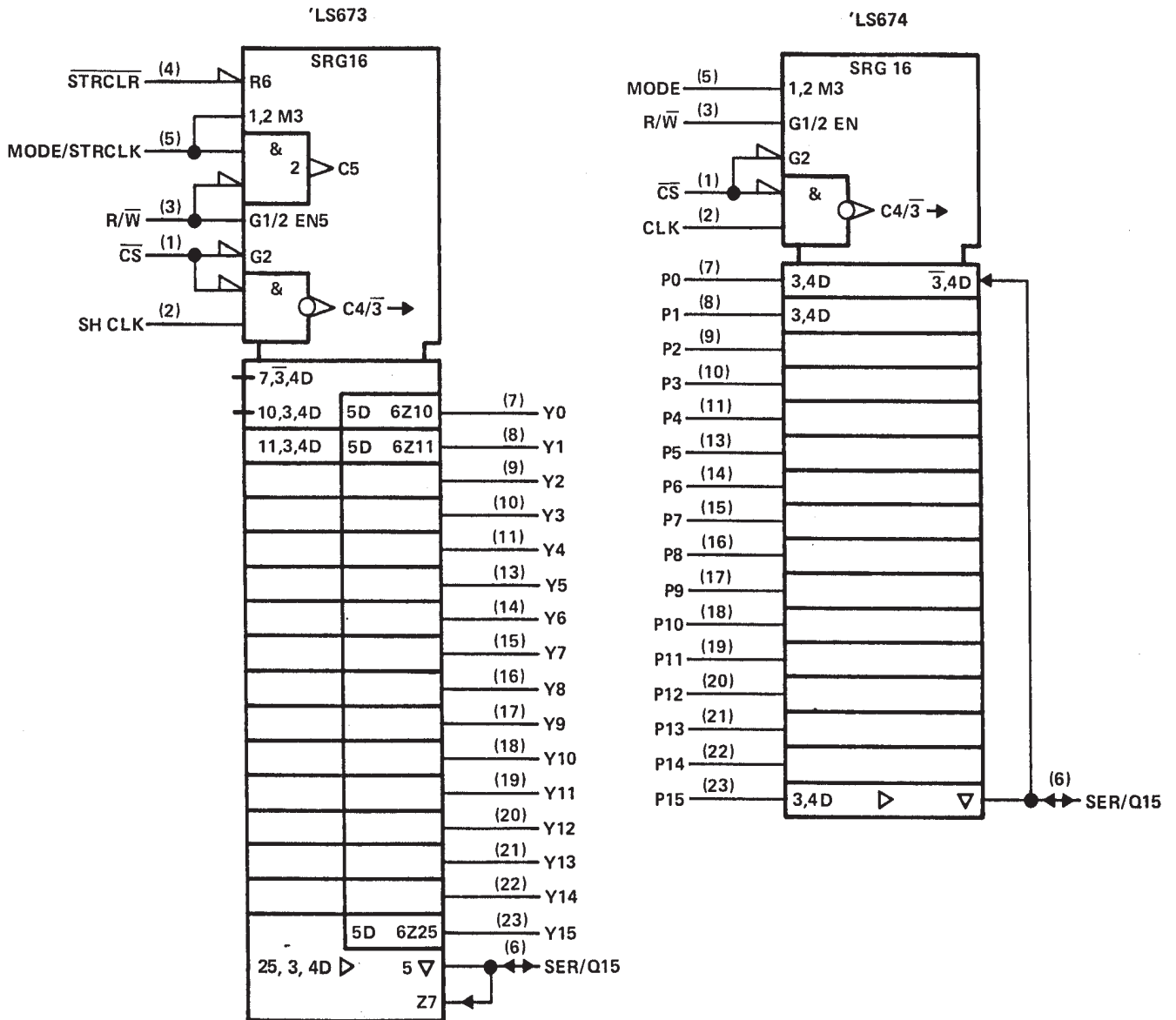

†These symbols are in accordance with ANSI/IEEE Std. 91-1984 and IEC Publication 617-12. Pin numbers shown are for DW, J, N, and W packages.

# SN54LS673, SN54LS674, SN74LS673, SN74LS674 16-BIT SHIFT REGISTERS

SDLS195 – MARCH 1985 – REVISED MARCH 1988

## functional block diagrams

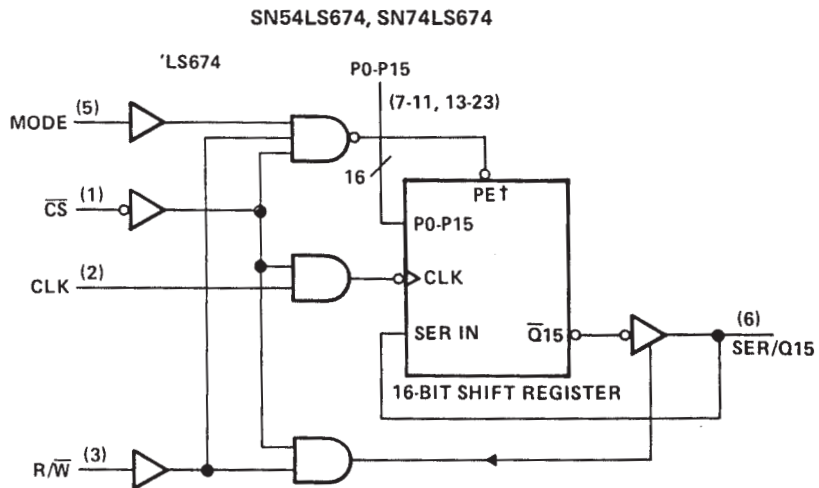
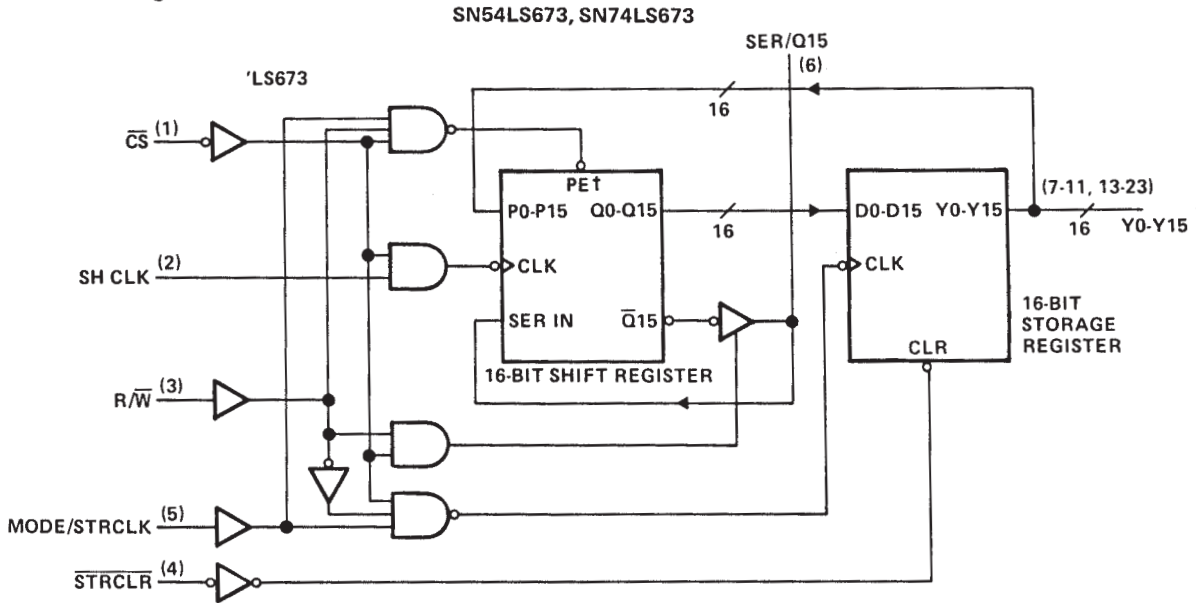

†When PE is active, data is synchronously parallel loaded into the shift registers from the 16 P inputs and no shifting takes place. Pin numbers shown are for DW, J, N, and W packages.

# SN54LS673, SN54LS674, SN74LS673, SN74LS674 16-BIT SHIFT REGISTERS

SDLS195 – MARCH 1985 – REVISED MARCH 1988

## schematics of inputs and outputs

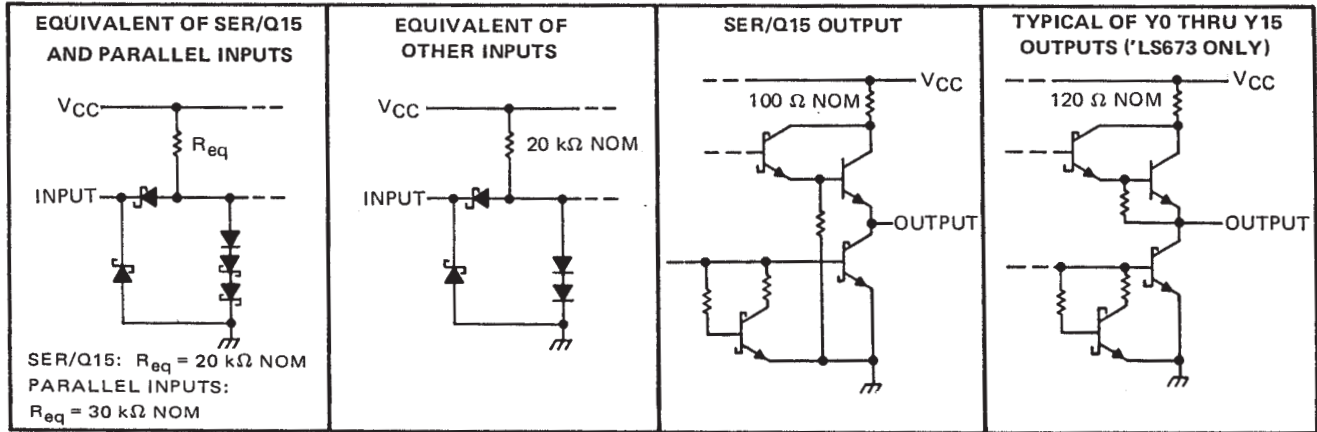

## absolute maximum ratings over operating free-air temperature range (unless otherwise noted)

Supply voltage, $V_{CC}$ (see Note 1)	7 V
Input voltage: SER/Q15	5.5 V
All others	7 V
Off-state output voltage	5.5 V
Operating free-air temperature range: SN54LS673, SN54LS674	-55°C to 125°C
SN74LS673, SN74LS674	0°C to 70°C
Storage temperature range	-65°C to 150°C

NOTE 1. Voltage values are with respect to network ground terminal.

## recommended operating conditions

		SN54LS'			SN74LS'			UNIT
		MIN	NOM	MAX	MIN	NOM	MAX	
$V_{CC}$	Supply voltage	4.5	5	5.5	4.75	5	5.25	V
$I_{OH}$	High-level output current	SER/Q15		-1	Y0 thru Y15		-2.6	mA
		Y0 thru Y15		-0.4	Y0 thru Y15		-0.4	
$I_{OL}$	Low-level output current	SER/Q15		12	Y0 thru Y15		24	mA
		Y0 thru Y15		4	Y0 thru Y15		8	
$f_{clock}$	Clock frequency	0		20	0		20	MHz
$t_{w(clock)}$	Width of clock input pulse	20			20			ns
$t_{w(clear)}$	Width of clear input pulse	20			20			ns
$t_{su}$	Setup time	SER/Q15		20	Y0 thru Y15		20	ns
		P0 thru P15		20	Y0 thru Y15		20	
		Mode		35	Y0 thru Y15		35	
		$R/\overline{W}$ , $\overline{CS}$		35	Y0 thru Y15		35	
		SH CLK ↓ to Mode/STR CLK ↑ See Note 2		25	Y0 thru Y15		25	
$t_h$	Hold time	SER/Q15		0	Y0 thru Y15		0	ns
		P0 thru P15	'LS673	0	Y0 thru Y15		0	
			'LS674	5.0	Y0 thru Y15		5.0	
Mode		0	Y0 thru Y15		0			
$T_A$	Operating free-air temperature	-55		125	0		70	°C

NOTE 2: This setup time ensures the storage register will see stable data from the shift register.



# SN54LS673, SN54LS674, SN74LS673, SN74LS674

## 16-BIT SHIFT REGISTERS

SDLS195 – MARCH 1985 – REVISED MARCH 1988

electrical characteristics over recommended operating free-air temperature range (unless otherwise noted)

PARAMETER		TEST CONDITIONS†	SN54LS'		SN74LS'		UNIT
			MIN	TYP‡	MAX	MIN	
V <sub>IH</sub>	High-level input voltage		2		2		V
V <sub>IL</sub>	Low-level input voltage			0.7		0.8	V
V <sub>IK</sub>	Input clamp voltage	V <sub>CC</sub> = MIN, I <sub>I</sub> = -18 mA		-1.5		-1.5	V
V <sub>OH</sub>	High-level output voltage	SER/Q15	V <sub>CC</sub> = MIN, V <sub>IH</sub> = 2 V,		2.4	3.1	V
		Y0 thru Y15¶	V <sub>IL</sub> = V <sub>ILmax</sub> , I <sub>OH</sub> = MAX		2.5	3.4	
V <sub>OL</sub>	Low-level output voltage	SER/Q15	V <sub>CC</sub> = MIN, V <sub>IH</sub> = 2 V,	I <sub>OL</sub> = 12 mA	0.25	0.4	V
				I <sub>OL</sub> = 24 mA		0.35	
		Y0 thru Y15¶	V <sub>IL</sub> = V <sub>ILmax</sub>	I <sub>OL</sub> = 4 mA	0.25	0.4	
				I <sub>OL</sub> = 8 mA		0.35	
I <sub>OZH</sub>	Off-state output current, high-level voltage applied	SER/Q15	V <sub>CC</sub> = MAX, V <sub>IH</sub> = 2 V, V <sub>IL</sub> = V <sub>ILmax</sub> , V <sub>O</sub> = 2.7 V	40		40	μA
I <sub>OZL</sub>	Off-state output current, low-level voltage applied	SER/Q15	V <sub>CC</sub> = MAX, V <sub>IH</sub> = 2 V, V <sub>IL</sub> = V <sub>ILmax</sub> , V <sub>O</sub> = 0.4 V	-0.4		-0.4	mA
I <sub>I</sub>	Input current at maximum input voltage	SER/Q15	V <sub>CC</sub> = MAX	V <sub>I</sub> = 5.5 V		0.1	mA
		Others		V <sub>I</sub> = 7 V		0.1	
I <sub>IH</sub>	High-level input current	SER/Q15	V <sub>CC</sub> = MAX, V <sub>I</sub> = 2.7 V			40	μA
		Others				20	
I <sub>IL</sub>	Low-level input current		V <sub>CC</sub> = MAX, V <sub>I</sub> = 0.4 V			-0.4	mA
I <sub>OS</sub>	Short-circuit output current§	SER/Q15	V <sub>CC</sub> = MAX		-30	-130	mA
		Y0 thru Y15¶			-20	-100	
I <sub>CC</sub>	Supply current	'LS673	V <sub>CC</sub> = MAX		50	80	mA
		'LS674			25	40	

† For conditions shown as MIN or MAX use the appropriate value specified under recommended operating conditions.

‡ All typical values are at V<sub>CC</sub> = 5 V, T<sub>A</sub> = 25°C.

§ Not more than one output should be shorted at a time, and duration of the short circuit should not exceed one second.

¶ 'LS673 only.

switching characteristics, V<sub>CC</sub> = 5 V, T<sub>A</sub> = 25°C, see note 2

PARAMETER	'LS673		'LS674		TEST CONDITIONS	MIN	TYP	MAX	UNIT
	FROM	TO	FROM	TO					
f <sub>max</sub>	SH CLK	SER/Q15	CLK	SER/Q15	R <sub>L</sub> = 667 Ω, C <sub>L</sub> = 45 pF	20	28		MHz
t <sub>PHL</sub>	STRCLR	Y0 thru Y15			R <sub>L</sub> = 2 kΩ, C <sub>L</sub> = 15 pF		25	40	ns
t <sub>PLH</sub>	MODE/ STRCLK	Y0 thru Y15					28	45	
t <sub>PHL</sub>							30	45	
t <sub>PLH</sub>	SH CLK	SER/Q15	CLK	SER/Q15	R <sub>L</sub> = 667 Ω, C <sub>L</sub> = 45 pF		21	33	ns
t <sub>PHL</sub>							26	40	
t <sub>PZH</sub>	CS, R/W	SER/Q15	CS, R/W	SER/Q15	R <sub>L</sub> = 667 Ω, C <sub>L</sub> = 45 pF		30	45	ns
t <sub>PZL</sub>							30	45	
t <sub>PHZ</sub>	CS, R/W	SER/Q15	CS, R/W	SER/Q15	R <sub>L</sub> = 667 Ω, C <sub>L</sub> = 5 pF		25	40	ns
t <sub>PLZ</sub>							25	40	

NOTE 2: Load circuits and voltage waveforms are shown in Section 1.



**PACKAGING INFORMATION**

Orderable Device	Status <sup>(1)</sup>	Package Type	Package Drawing	Pins	Package Qty	Eco Plan <sup>(2)</sup>	Lead/Ball Finish	MSL Peak Temp <sup>(3)</sup>
5962-88602013A	ACTIVE	LCCC	FK	28	1	TBD	POST-PLATE	N / A for Pkg Type
5962-8860201JA	ACTIVE	CDIP	J	24	1	TBD	Call TI	N / A for Pkg Type
5962-8860201JA	ACTIVE	CDIP	J	24	1	TBD	Call TI	N / A for Pkg Type
5962-8860201KA	OBSOLETE	CFP	W	24		TBD	Call TI	Call TI
5962-8860201KA	OBSOLETE	CFP	W	24		TBD	Call TI	Call TI
5962-8860201LA	ACTIVE	CDIP	JT	24	1	TBD	A42	N / A for Pkg Type
5962-8860201LA	ACTIVE	CDIP	JT	24	1	TBD	A42	N / A for Pkg Type
5962-88607013A	ACTIVE	LCCC	FK	28	1	TBD	POST-PLATE	N / A for Pkg Type
5962-88607013A	ACTIVE	LCCC	FK	28	1	TBD	POST-PLATE	N / A for Pkg Type
5962-8860701JA	ACTIVE	CDIP	J	24	1	TBD	Call TI	N / A for Pkg Type
5962-8860701JA	ACTIVE	CDIP	J	24	1	TBD	Call TI	N / A for Pkg Type
5962-8860701KA	OBSOLETE	CFP	W	24		TBD	Call TI	Call TI
5962-8860701KA	OBSOLETE	CFP	W	24		TBD	Call TI	Call TI
SN54LS673J	ACTIVE	CDIP	J	24	1	TBD	Call TI	N / A for Pkg Type
SN54LS673J	ACTIVE	CDIP	J	24	1	TBD	Call TI	N / A for Pkg Type
SN54LS674J	ACTIVE	CDIP	J	24	1	TBD	Call TI	N / A for Pkg Type
SN54LS674J	ACTIVE	CDIP	J	24	1	TBD	Call TI	N / A for Pkg Type
SN74LS673DW	ACTIVE	SOIC	DW	24	25	Green (RoHS & no Sb/Br)	CU NIPDAU	Level-1-260C-UNLIM
SN74LS673DW	ACTIVE	SOIC	DW	24	25	Green (RoHS & no Sb/Br)	CU NIPDAU	Level-1-260C-UNLIM
SN74LS673DWE4	ACTIVE	SOIC	DW	24	25	Green (RoHS & no Sb/Br)	CU NIPDAU	Level-1-260C-UNLIM
SN74LS673DWE4	ACTIVE	SOIC	DW	24	25	Green (RoHS & no Sb/Br)	CU NIPDAU	Level-1-260C-UNLIM
SN74LS673DWG4	ACTIVE	SOIC	DW	24	25	Green (RoHS & no Sb/Br)	CU NIPDAU	Level-1-260C-UNLIM
SN74LS673DWG4	ACTIVE	SOIC	DW	24	25	Green (RoHS & no Sb/Br)	CU NIPDAU	Level-1-260C-UNLIM
SN74LS673N	ACTIVE	PDIP	N	24	15	Pb-Free (RoHS)	CU NIPDAU	N / A for Pkg Type
SN74LS673N	ACTIVE	PDIP	N	24	15	Pb-Free (RoHS)	CU NIPDAU	N / A for Pkg Type
SN74LS673NE4	ACTIVE	PDIP	N	24	15	Pb-Free (RoHS)	CU NIPDAU	N / A for Pkg Type
SN74LS673NE4	ACTIVE	PDIP	N	24	15	Pb-Free (RoHS)	CU NIPDAU	N / A for Pkg Type
SN74LS674DW	ACTIVE	SOIC	DW	24	25	Green (RoHS & no Sb/Br)	CU NIPDAU	Level-1-260C-UNLIM
SN74LS674DW	ACTIVE	SOIC	DW	24	25	Green (RoHS & no Sb/Br)	CU NIPDAU	Level-1-260C-UNLIM
SN74LS674DWG4	ACTIVE	SOIC	DW	24	25	Green (RoHS & no Sb/Br)	CU NIPDAU	Level-1-260C-UNLIM
SN74LS674DWG4	ACTIVE	SOIC	DW	24	25	Green (RoHS & no Sb/Br)	CU NIPDAU	Level-1-260C-UNLIM
SN74LS674N	ACTIVE	PDIP	N	24	15	Pb-Free	CU NIPDAU	N / A for Pkg Type

Orderable Device	Status <sup>(1)</sup>	Package Type	Package Drawing	Pins	Package Qty	Eco Plan <sup>(2)</sup>	Lead/Ball Finish	MSL Peak Temp <sup>(3)</sup>
						(RoHS)		
SN74LS674N	ACTIVE	PDIP	N	24	15	Pb-Free (RoHS)	CU NIPDAU	N / A for Pkg Type
SN74LS674NE4	ACTIVE	PDIP	N	24	15	Pb-Free (RoHS)	CU NIPDAU	N / A for Pkg Type
SN74LS674NE4	ACTIVE	PDIP	N	24	15	Pb-Free (RoHS)	CU NIPDAU	N / A for Pkg Type
SNJ54LS673FK	ACTIVE	LCCC	FK	28	1	TBD	POST-PLATE	N / A for Pkg Type
SNJ54LS673FK	ACTIVE	LCCC	FK	28	1	TBD	POST-PLATE	N / A for Pkg Type
SNJ54LS673J	ACTIVE	CDIP	J	24	1	TBD	Call TI	N / A for Pkg Type
SNJ54LS673J	ACTIVE	CDIP	J	24	1	TBD	Call TI	N / A for Pkg Type
SNJ54LS673JT	ACTIVE	CDIP	JT	24	1	TBD	A42	N / A for Pkg Type
SNJ54LS673JT	ACTIVE	CDIP	JT	24	1	TBD	A42	N / A for Pkg Type
SNJ54LS673W	OBSOLETE	CFP	W	24		TBD	Call TI	Call TI
SNJ54LS673W	OBSOLETE	CFP	W	24		TBD	Call TI	Call TI
SNJ54LS674FK	ACTIVE	LCCC	FK	28	1	TBD	POST-PLATE	N / A for Pkg Type
SNJ54LS674FK	ACTIVE	LCCC	FK	28	1	TBD	POST-PLATE	N / A for Pkg Type
SNJ54LS674J	ACTIVE	CDIP	J	24	1	TBD	Call TI	N / A for Pkg Type
SNJ54LS674J	ACTIVE	CDIP	J	24	1	TBD	Call TI	N / A for Pkg Type
SNJ54LS674JT	ACTIVE	CDIP	JT	24	1	TBD	A42	N / A for Pkg Type
SNJ54LS674JT	ACTIVE	CDIP	JT	24	1	TBD	A42	N / A for Pkg Type
SNJ54LS674W	OBSOLETE	CFP	W	24		TBD	Call TI	Call TI
SNJ54LS674W	OBSOLETE	CFP	W	24		TBD	Call TI	Call TI

<sup>(1)</sup> The marketing status values are defined as follows:

**ACTIVE:** Product device recommended for new designs.

**LIFEBUY:** TI has announced that the device will be discontinued, and a lifetime-buy period is in effect.

**NRND:** Not recommended for new designs. Device is in production to support existing customers, but TI does not recommend using this part in a new design.

**PREVIEW:** Device has been announced but is not in production. Samples may or may not be available.

**OBSOLETE:** TI has discontinued the production of the device.

<sup>(2)</sup> Eco Plan - The planned eco-friendly classification: Pb-Free (RoHS), Pb-Free (RoHS Exempt), or Green (RoHS & no Sb/Br) - please check <http://www.ti.com/productcontent> for the latest availability information and additional product content details.

**TBD:** The Pb-Free/Green conversion plan has not been defined.

**Pb-Free (RoHS):** TI's terms "Lead-Free" or "Pb-Free" mean semiconductor products that are compatible with the current RoHS requirements for all 6 substances, including the requirement that lead not exceed 0.1% by weight in homogeneous materials. Where designed to be soldered at high temperatures, TI Pb-Free products are suitable for use in specified lead-free processes.

**Pb-Free (RoHS Exempt):** This component has a RoHS exemption for either 1) lead-based flip-chip solder bumps used between the die and package, or 2) lead-based die adhesive used between the die and leadframe. The component is otherwise considered Pb-Free (RoHS compatible) as defined above.

**Green (RoHS & no Sb/Br):** TI defines "Green" to mean Pb-Free (RoHS compatible), and free of Bromine (Br) and Antimony (Sb) based flame retardants (Br or Sb do not exceed 0.1% by weight in homogeneous material)

<sup>(3)</sup> MSL, Peak Temp. -- The Moisture Sensitivity Level rating according to the JEDEC industry standard classifications, and peak solder temperature.

**Important Information and Disclaimer:** The information provided on this page represents TI's knowledge and belief as of the date that it is provided. TI bases its knowledge and belief on information provided by third parties, and makes no representation or warranty as to the accuracy of such information. Efforts are underway to better integrate information from third parties. TI has taken and continues to take reasonable steps to provide representative and accurate information but may not have conducted destructive testing or chemical analysis on incoming materials and chemicals. TI and TI suppliers consider certain information to be proprietary, and thus CAS numbers and other limited information may not be available for release.

In no event shall TI's liability arising out of such information exceed the total purchase price of the TI part(s) at issue in this document sold by TI to Customer on an annual basis.

J (R-GDIP-T\*\*)

CERAMIC DUAL-IN-LINE PACKAGE

24 PINS SHOWN

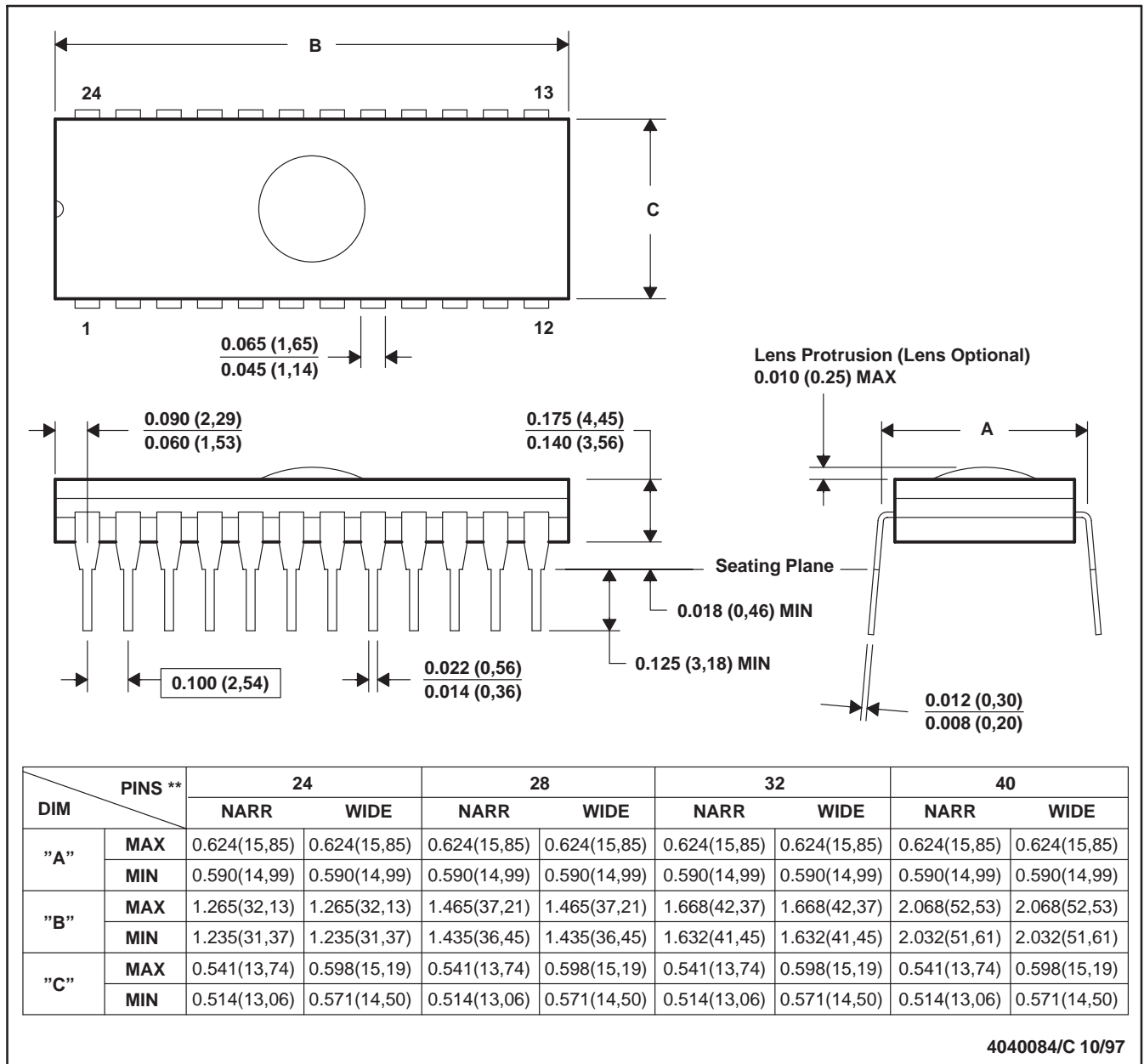

- NOTES: A. All linear dimensions are in inches (millimeters).  
 B. This drawing is subject to change without notice.  
 C. Window (lens) added to this group of packages (24-, 28-, 32-, 40-pin).  
 D. This package can be hermetically sealed with a ceramic lid using glass frit.  
 E. Index point is provided on cap for terminal identification.

JT (R-GDIP-T\*\*)

CERAMIC DUAL-IN-LINE

24 LEADS SHOWN

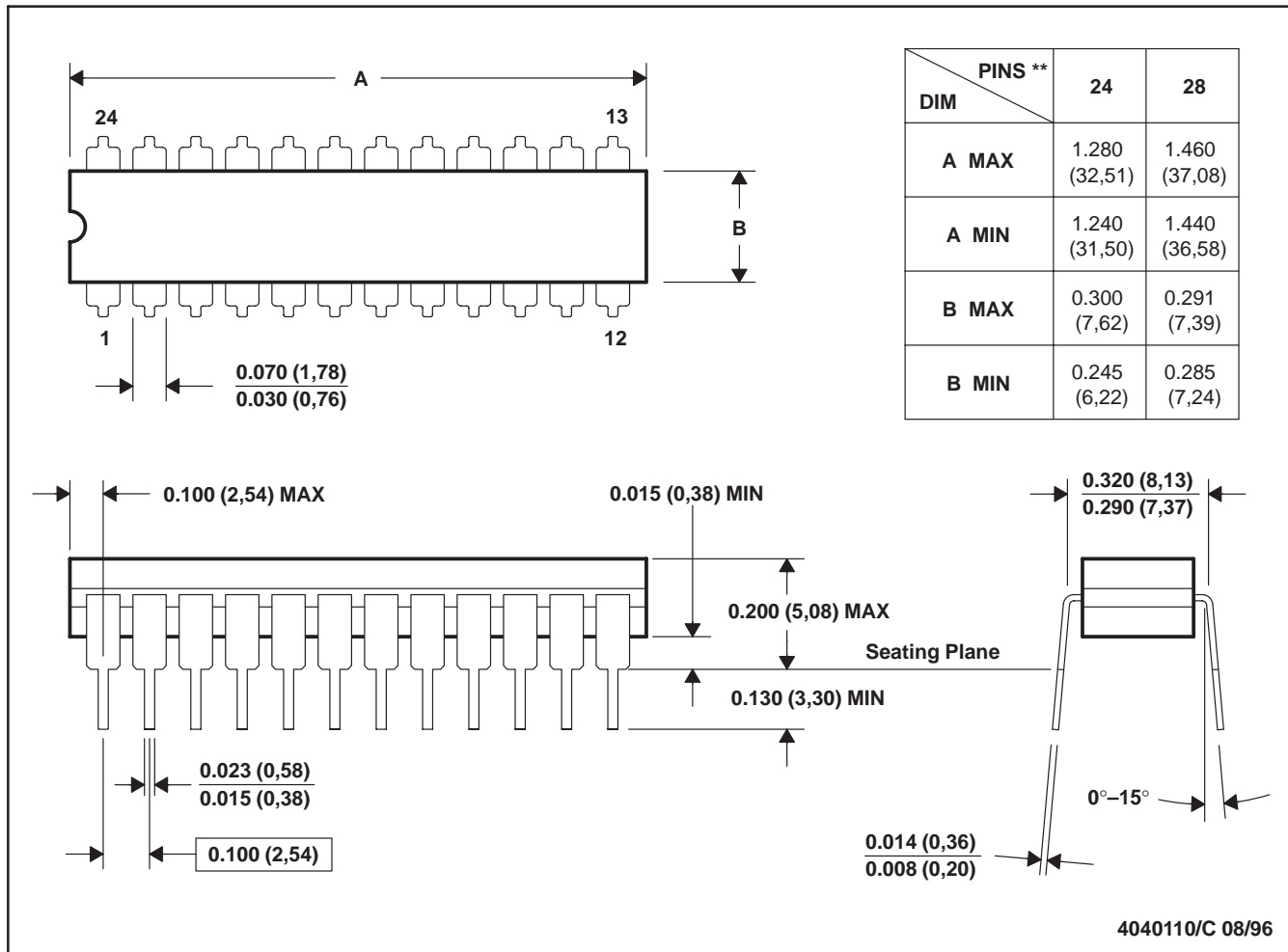

- NOTES: A. All linear dimensions are in inches (millimeters).  
 B. This drawing is subject to change without notice.  
 C. This package can be hermetically sealed with a ceramic lid using glass frit.  
 D. Index point is provided on cap for terminal identification.  
 E. Falls within MIL STD 1835 GDIP3-T24, GDIP4-T28, and JEDEC MO-058 AA, MO-058 AB

W (R-GDFP-F24)

CERAMIC DUAL FLATPACK

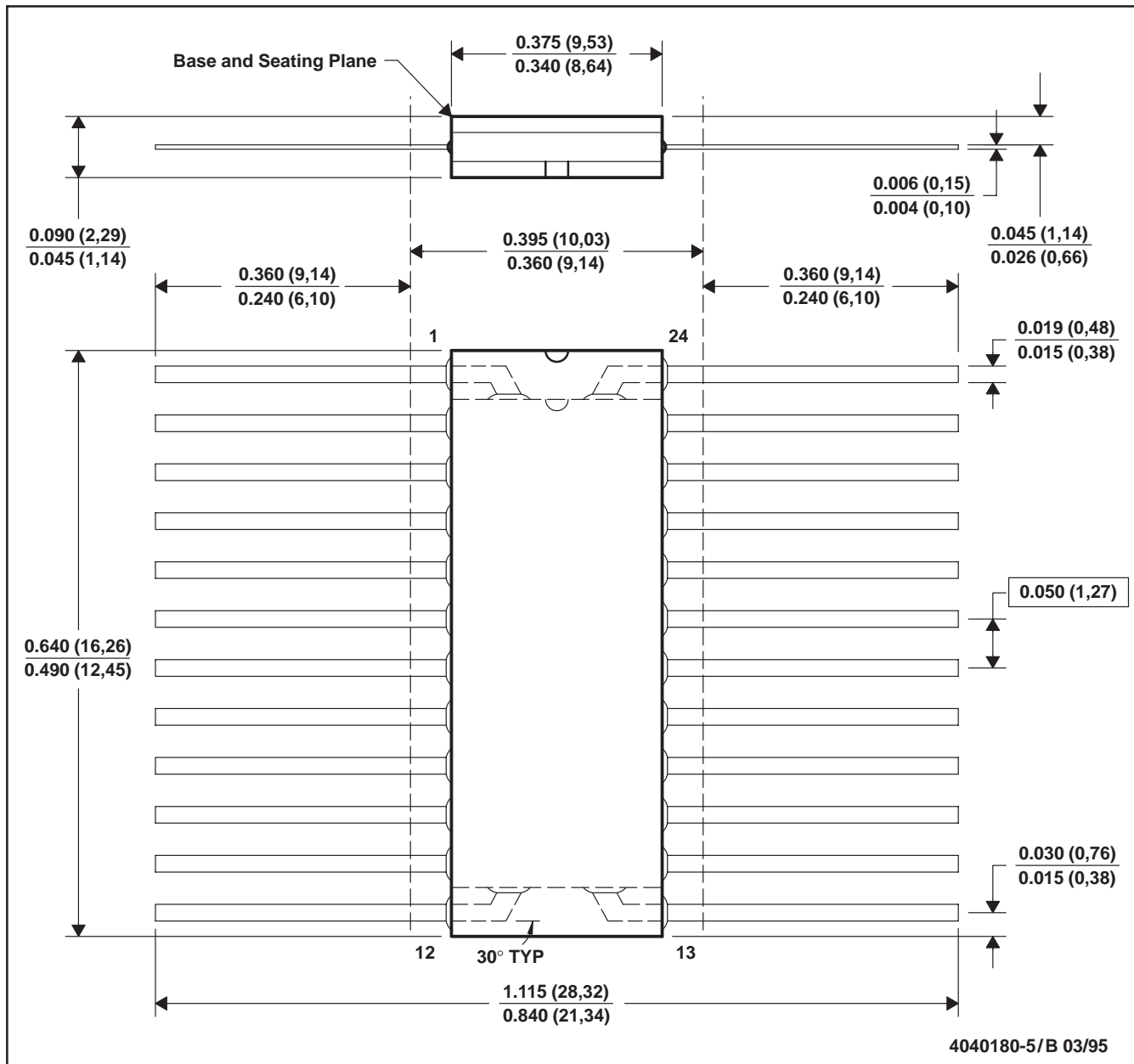

- NOTES:
- A. All linear dimensions are in inches (millimeters).
  - B. This drawing is subject to change without notice.
  - C. This package can be hermetically sealed with a ceramic lid using glass frit.
  - D. Falls within MIL-STD-1835 GDFP2-F24 and JEDEC MO-070AD
  - E. Index point is provided on cap for terminal identification only.

FK (S-CQCC-N\*\*)

LEADLESS CERAMIC CHIP CARRIER

28 TERMINAL SHOWN



NO. OF TERMINALS **	A		B	
	MIN	MAX	MIN	MAX
20	0.342 (8,69)	0.358 (9,09)	0.307 (7,80)	0.358 (9,09)
28	0.442 (11,23)	0.458 (11,63)	0.406 (10,31)	0.458 (11,63)
44	0.640 (16,26)	0.660 (16,76)	0.495 (12,58)	0.560 (14,22)
52	0.740 (18,78)	0.761 (19,32)	0.495 (12,58)	0.560 (14,22)
68	0.938 (23,83)	0.962 (24,43)	0.850 (21,6)	0.858 (21,8)
84	1.141 (28,99)	1.165 (29,59)	1.047 (26,6)	1.063 (27,0)



4040140/D 01/11

- NOTES:
- All linear dimensions are in inches (millimeters).
  - This drawing is subject to change without notice.
  - This package can be hermetically sealed with a metal lid.
  - Falls within JEDEC MS-004

N (R-PDIP-T24)

PLASTIC DUAL-IN-LINE

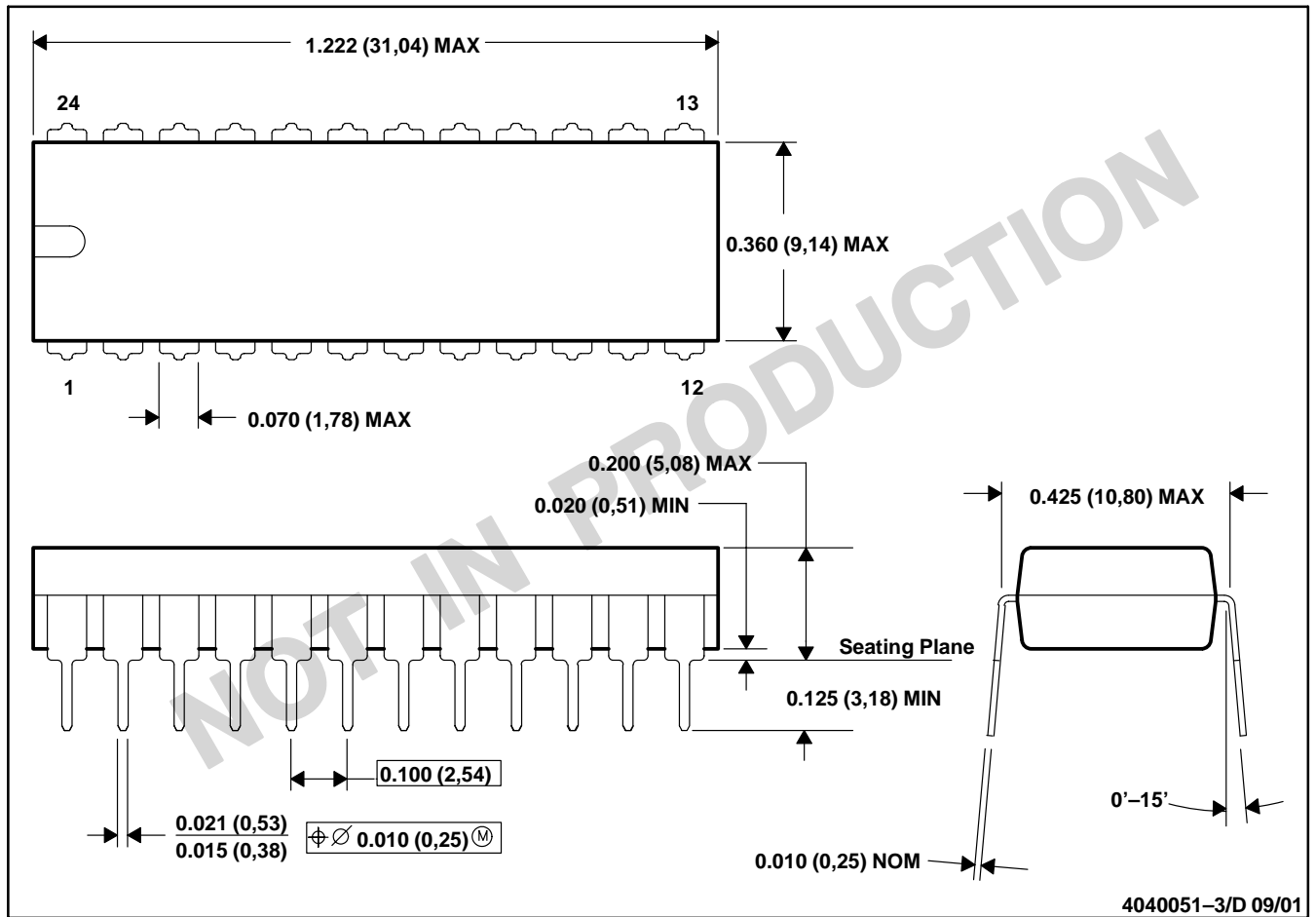

- NOTES: A. All linear dimensions are in inches (millimeters).  
 B. This drawing is subject to change without notice.  
 C. Falls within JEDEC MS-010

**N (R-PDIP-T\*\*)**

**PLASTIC DUAL-IN-LINE PACKAGE**

24 PIN SHOWN

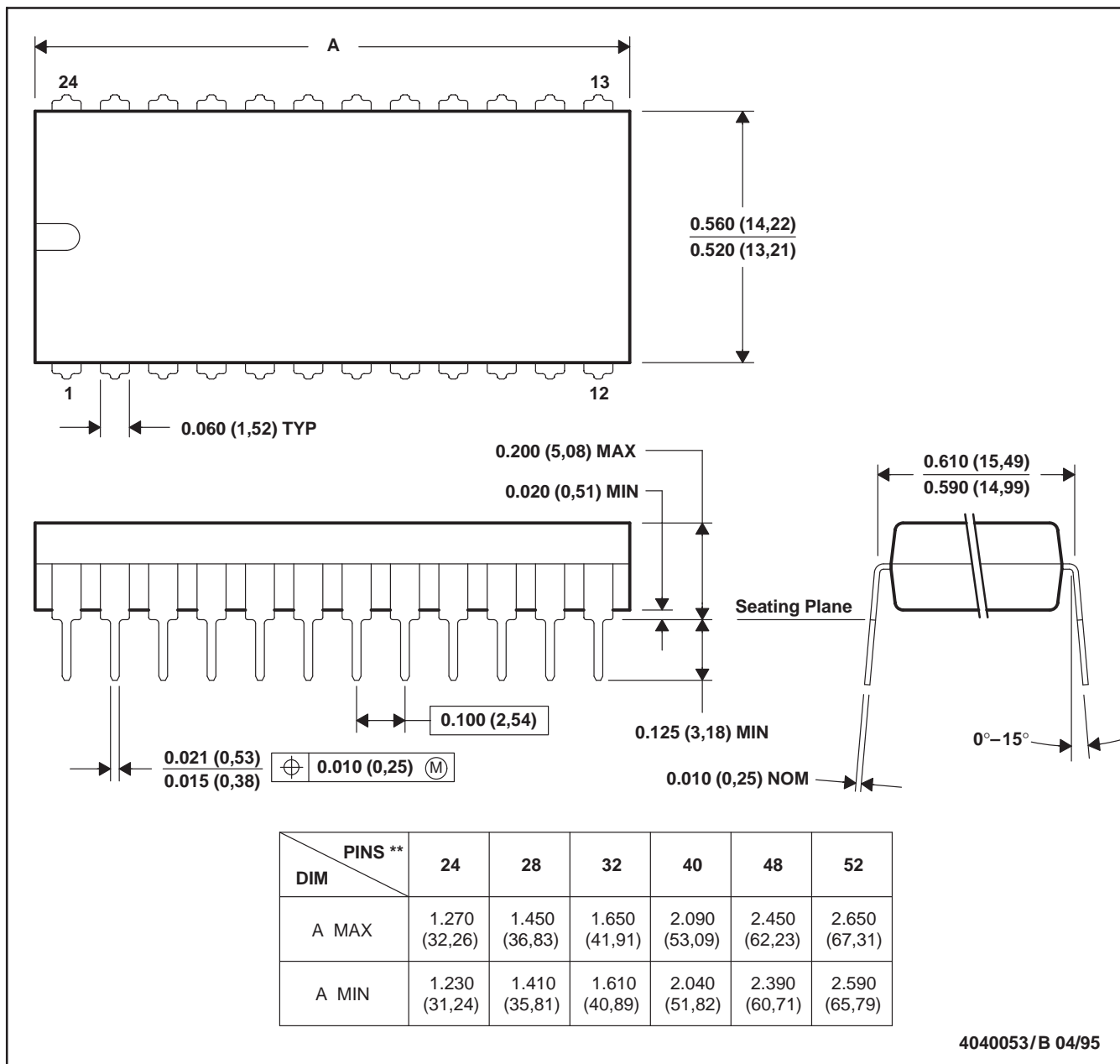

- NOTES: A. All linear dimensions are in inches (millimeters).  
 B. This drawing is subject to change without notice.  
 C. Falls within JEDEC MS-011  
 D. Falls within JEDEC MS-015 (32 pin only)



## IMPORTANT NOTICE

Texas Instruments Incorporated and its subsidiaries (TI) reserve the right to make corrections, modifications, enhancements, improvements, and other changes to its products and services at any time and to discontinue any product or service without notice. Customers should obtain the latest relevant information before placing orders and should verify that such information is current and complete. All products are sold subject to TI's terms and conditions of sale supplied at the time of order acknowledgment.

TI warrants performance of its hardware products to the specifications applicable at the time of sale in accordance with TI's standard warranty. Testing and other quality control techniques are used to the extent TI deems necessary to support this warranty. Except where mandated by government requirements, testing of all parameters of each product is not necessarily performed.

TI assumes no liability for applications assistance or customer product design. Customers are responsible for their products and applications using TI components. To minimize the risks associated with customer products and applications, customers should provide adequate design and operating safeguards.

TI does not warrant or represent that any license, either express or implied, is granted under any TI patent right, copyright, mask work right, or other TI intellectual property right relating to any combination, machine, or process in which TI products or services are used. Information published by TI regarding third-party products or services does not constitute a license from TI to use such products or services or a warranty or endorsement thereof. Use of such information may require a license from a third party under the patents or other intellectual property of the third party, or a license from TI under the patents or other intellectual property of TI.

Reproduction of TI information in TI data books or data sheets is permissible only if reproduction is without alteration and is accompanied by all associated warranties, conditions, limitations, and notices. Reproduction of this information with alteration is an unfair and deceptive business practice. TI is not responsible or liable for such altered documentation. Information of third parties may be subject to additional restrictions.

Resale of TI products or services with statements different from or beyond the parameters stated by TI for that product or service voids all express and any implied warranties for the associated TI product or service and is an unfair and deceptive business practice. TI is not responsible or liable for any such statements.

TI products are not authorized for use in safety-critical applications (such as life support) where a failure of the TI product would reasonably be expected to cause severe personal injury or death, unless officers of the parties have executed an agreement specifically governing such use. Buyers represent that they have all necessary expertise in the safety and regulatory ramifications of their applications, and acknowledge and agree that they are solely responsible for all legal, regulatory and safety-related requirements concerning their products and any use of TI products in such safety-critical applications, notwithstanding any applications-related information or support that may be provided by TI. Further, Buyers must fully indemnify TI and its representatives against any damages arising out of the use of TI products in such safety-critical applications.

TI products are neither designed nor intended for use in military/aerospace applications or environments unless the TI products are specifically designated by TI as military-grade or "enhanced plastic." Only products designated by TI as military-grade meet military specifications. Buyers acknowledge and agree that any such use of TI products which TI has not designated as military-grade is solely at the Buyer's risk, and that they are solely responsible for compliance with all legal and regulatory requirements in connection with such use.

TI products are neither designed nor intended for use in automotive applications or environments unless the specific TI products are designated by TI as compliant with ISO/TS 16949 requirements. Buyers acknowledge and agree that, if they use any non-designated products in automotive applications, TI will not be responsible for any failure to meet such requirements.

Following are URLs where you can obtain information on other Texas Instruments products and application solutions:

### Products

Audio	<a href="http://www.ti.com/audio">www.ti.com/audio</a>
Amplifiers	<a href="http://amplifier.ti.com">amplifier.ti.com</a>
Data Converters	<a href="http://dataconverter.ti.com">dataconverter.ti.com</a>
DLP® Products	<a href="http://www.dlp.com">www.dlp.com</a>
DSP	<a href="http://dsp.ti.com">dsp.ti.com</a>
Clocks and Timers	<a href="http://www.ti.com/clocks">www.ti.com/clocks</a>
Interface	<a href="http://interface.ti.com">interface.ti.com</a>
Logic	<a href="http://logic.ti.com">logic.ti.com</a>
Power Mgmt	<a href="http://power.ti.com">power.ti.com</a>
Microcontrollers	<a href="http://microcontroller.ti.com">microcontroller.ti.com</a>
RFID	<a href="http://www.ti-rfid.com">www.ti-rfid.com</a>
RF/IF and ZigBee® Solutions	<a href="http://www.ti.com/lprf">www.ti.com/lprf</a>

### Applications

Communications and Telecom	<a href="http://www.ti.com/communications">www.ti.com/communications</a>
Computers and Peripherals	<a href="http://www.ti.com/computers">www.ti.com/computers</a>
Consumer Electronics	<a href="http://www.ti.com/consumer-apps">www.ti.com/consumer-apps</a>
Energy and Lighting	<a href="http://www.ti.com/energy">www.ti.com/energy</a>
Industrial	<a href="http://www.ti.com/industrial">www.ti.com/industrial</a>
Medical	<a href="http://www.ti.com/medical">www.ti.com/medical</a>
Security	<a href="http://www.ti.com/security">www.ti.com/security</a>
Space, Avionics and Defense	<a href="http://www.ti.com/space-avionics-defense">www.ti.com/space-avionics-defense</a>
Transportation and Automotive	<a href="http://www.ti.com/automotive">www.ti.com/automotive</a>
Video and Imaging	<a href="http://www.ti.com/video">www.ti.com/video</a>
Wireless	<a href="http://www.ti.com/wireless-apps">www.ti.com/wireless-apps</a>

TI E2E Community Home Page

[e2e.ti.com](http://e2e.ti.com)

Mailing Address: Texas Instruments, Post Office Box 655303, Dallas, Texas 75265  
Copyright © 2011, Texas Instruments Incorporated