

Distributed by:

JAMECO[®]
ELECTRONICS

www.Jameco.com ♦ 1-800-831-4242

The content and copyrights of the attached
material are the property of its owner.

Jameco Part Number 816641

SN54LS651 THRU SN54LS653 SN74LS651 THRU SN74LS653 OCTAL BUS TRANSCEIVERS AND REGISTERS

SDLS191A – JANUARY 1981 – REVISED DECEMBER 2000

- Bus Transceivers/Registers
- Independent Registers and Enables for A and B Buses
- Multiplexed Real-Time and Stored Data
- Choice of True and Inverting Data Paths
- Choice of 3-State or Open-Collector Outputs to A Bus
- Dependable Texas Instruments Quality and Reliability

DEVICE	A OUTPUT	B OUTPUT	LOGIC
'LS651	3-State	3-State	Inverting
'LS652	3-State	3-State	True
'LS653	Open-collector	3-State	Inverting

description

These devices consist of bus transceiver circuits, D-type flip-flops, and control circuitry arranged for multiplexed transmission of data directly from the data bus or from the internal storage registers. Enable GAB and $\overline{\text{GBA}}$ are provided to control the transceiver functions. SAB and SBA control pins are provided to select whether real-time or stored data is transferred. A low input level selects real-time data, and a high selects stored data. The following examples demonstrate the four fundamental bus-management functions that can be performed with the 'LS651, 'LS652, and 'LS653.

SN54LS' . . . JT PACKAGE
SN74LS' . . . DW OR NT PACKAGE
(TOP VIEW)

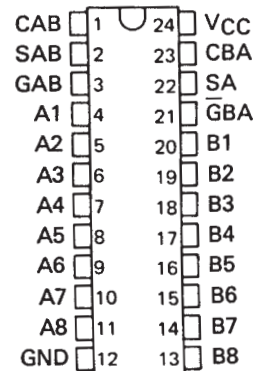

SN54LS' . . . FK PACKAGE
(TOP VIEW)

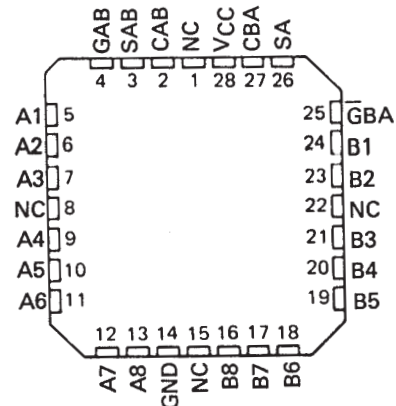

NC — No internal connection

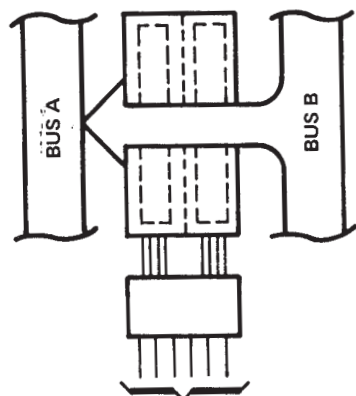

GAB $\overline{\text{GBA}}$ CAB CBA SAB SBA
L L X X X L

REAL-TIME TRANSFER
BUS B TO BUS A

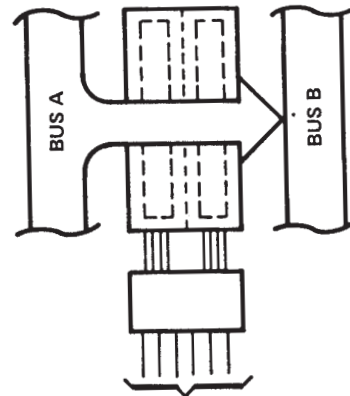

GAB $\overline{\text{GBA}}$ CAB CBA SAB SBA
H H X X L X

REAL-TIME TRANSFER
BUS A TO BUS B

PRODUCTION DATA information is current as of publication date. Products conform to specifications per the terms of Texas Instruments standard warranty. Production processing does not necessarily include testing of all parameters.



POST OFFICE BOX 655303 • DALLAS, TEXAS 75265

Copyright © 2000, Texas Instruments Incorporated

SN54LS651 THRU SN54LS653
SN74LS651 THRU SN74LS653
OCTAL BUS TRANSCEIVERS AND REGISTERS

SDLS191A – JANUARY 1981 – REVISED DECEMBER 2000

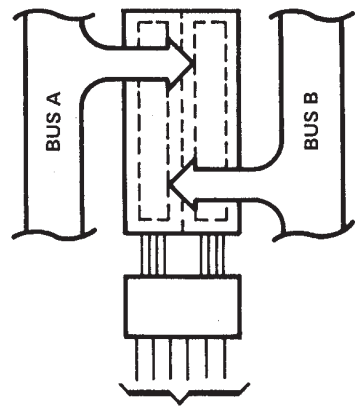

GAB	$\overline{\text{GBA}}$	CAB	CBA	SAB	SBA
X	H	↑	X	X	X
L	X	X	↑	X	X
L	H	↑	↑	X	X

**STORAGE FROM
A AND/OR B**

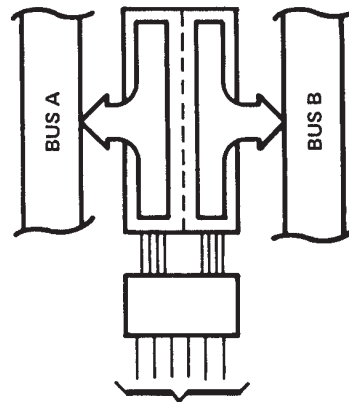

GAB	$\overline{\text{GBA}}$	CAB	CBA	SAB	SBA
H	L	H or L	H or L	H	H

**TRANSFER
STORED DATA
TO A AND/OR B**

Data on the A or B data bus, or both, can be stored in the internal D flip-flop by low-to-high transitions at the appropriate clock pins (CAB or CBA) regardless of the select or enable control pins. When SAB or SBA are in the real-time transfer mode, it is also possible to store data without using the internal D-type flip-flops by simultaneously enabling GAB and $\overline{\text{GBA}}$. In this configuration each output reinforces its input. Thus, when all other data sources to the two sets of bus lines are at high impedance, each set of bus lines will remain at its last state.

The SN54LS651 through SN54LS653 are characterized for operation over the full military temperature range of -55°C to 125°C . The SN74LS651 through SN74LS653 are characterized for operation from 0°C to 70°C .

FUNCTION TABLE

INPUTS						DATA I/O*		OPERATION OR FUNCTION	
GAB	$\overline{\text{GBA}}$	CAB	CBA	SAB	SBA	A1 THRU A8	B1 THRU B8	'LS651, 'LS653	'LS652, 'LS654
L	H	H or L	H or L	X	X	Input	Input	Isolation	Isolation
L	H	↑	↑	X	X	Input	Input	Store A and B Data	Store A and B Data
X	H	↑	H or L	X	X	Input	Not specified	Store A, Hold B	Store A, Hold B
H	H	↑	↑	X	X	Input	Output	Store A in both registers	Store A in both registers
L	X	H or L	↑	X	X	Not specified	Input	Hold A, Store B	Hold A, Store B
L	L	↑	↑	X	X	Output	Input	Store B in both registers	Store B in both registers
L	L	X	X	X	L	Output	Input	Real-Time $\overline{\text{B}}$ Data to A Bus	Real-Time B Data to A Bus
L	L	X	H or L	X	H	Output	Input	Stored $\overline{\text{B}}$ Data to A Bus	Stored B Data to A Bus
H	H	X	X	L	X	Input	Output	Real-Time $\overline{\text{A}}$ Data to B Bus	Real-Time A Data to B Bus
H	H	H or L	X	H	X	Input	Output	Stored $\overline{\text{A}}$ Data to B Bus	Stored A Data to B Bus
H	L	H or L	H or L	H	H	Output	Output	Stored $\overline{\text{A}}$ Data to B Bus and Stored $\overline{\text{B}}$ Data to A Bus	Stored A Data to B Bus and Stored B Data to A Bus

* The data output functions may be enabled or disabled by various signals at the GAB and $\overline{\text{GBA}}$ inputs. Data input functions are always enabled, i.e., data at the bus pins will be stored on every low-to-high transition on the clock inputs.

SN54LS651 THRU SN54LS653
SN74LS651 THRU SN74LS653
OCTAL BUS TRANSCEIVERS AND REGISTERS

SDLS191A - JANUARY 1981 - REVISED DECEMBER 2000

logic diagrams (positive logic)

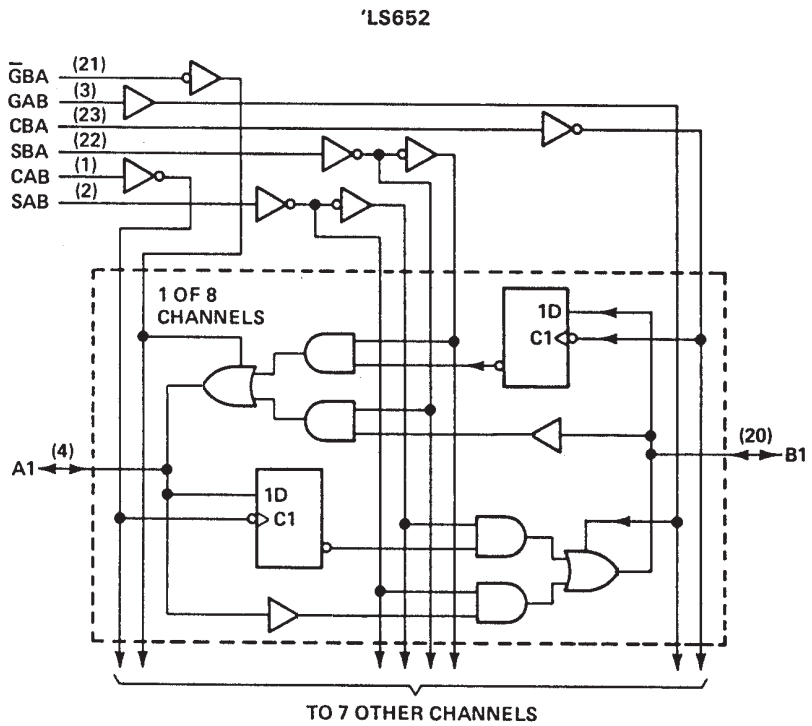
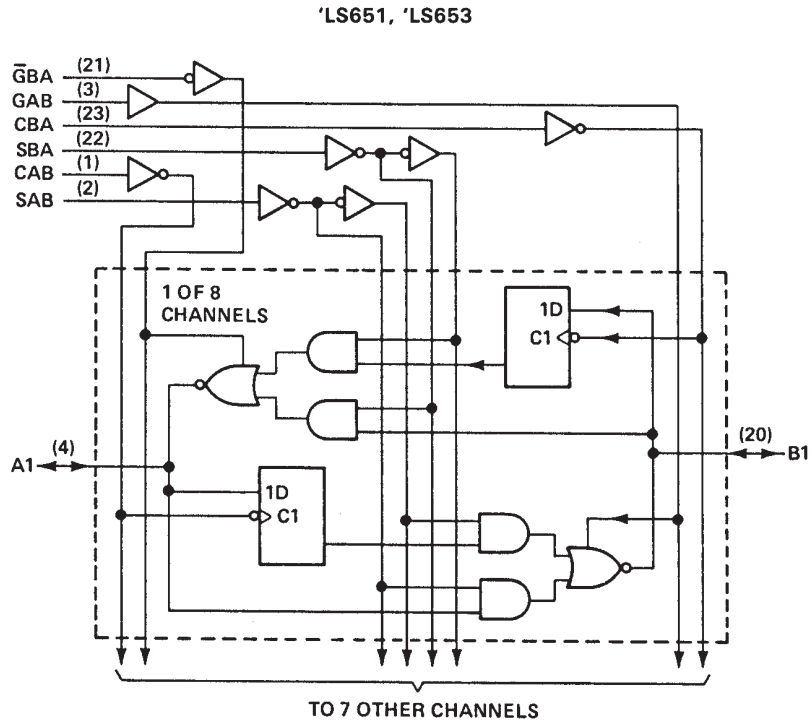

Pin numbers shown are for DW, JT or NT packages.

SN54LS651 THRU SN54LS653 SN74LS651 THRU SN74LS653 OCTAL BUS TRANSCEIVERS AND REGISTERS

SDLS191A - JANUARY 1981 - REVISED DECEMBER 2000

logic symbols†

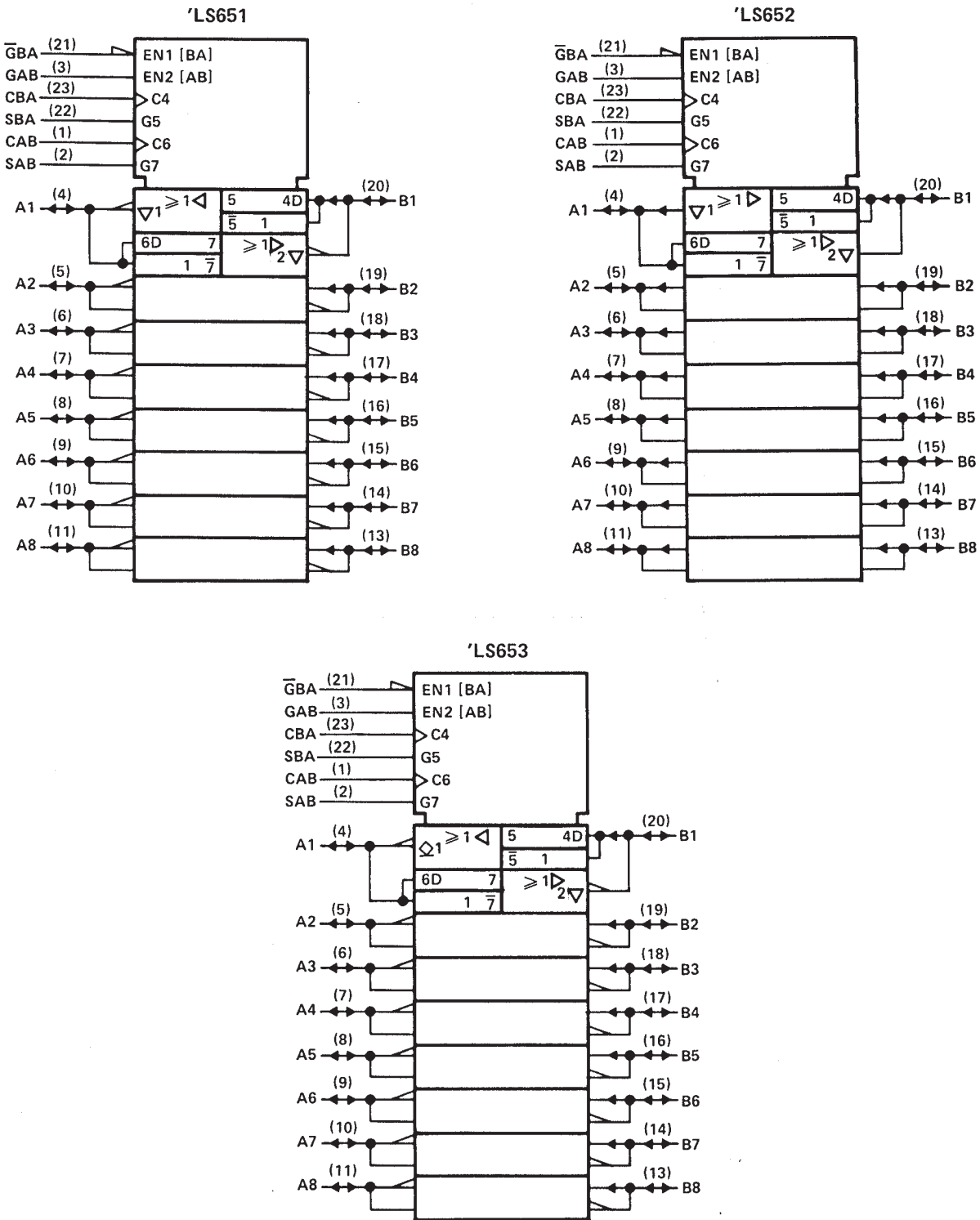

†This symbol is in accordance with ANSI/IEEE Std. 91-1984 and IEC Publication 617-12. Pin numbers shown are for DW, JT, or NT packages.

SN54LS651, SN54LS652, SN74LS651, SN74LS652 OCTAL BUS TRANSCEIVERS AND REGISTERS

SDLS191 – JANUARY 1981 – REVISED MARCH 1988

absolute maximum ratings over operating free-air temperature range (unless otherwise noted)

Supply voltage, V_{CC}	7 V
Input voltage: Control inputs	7 V
I/O ports	5.5 V
Operating free-air temperature range: SN54LS651, SN54LS652	- 55°C to 125°C
SN74LS651, SN74LS652	0°C to 70°C
Storage temperature range	- 65°C to 150°C

recommended operating conditions

		SN54LS651 SN54LS652			SN74LS651 SN74LS652			UNIT
		MIN	NOM	MAX	MIN	NOM	MAX	
V_{CC}	Supply voltage	4.5	5	5.5	4.75	5	5.25	V
V_{IH}	High-level input voltage	2			2			V
V_{IL}	Low-level input voltage			0.7			0.8	V
I_{OH}	High-level output current			- 12			- 15	mA
I_{OL}	Low-level output current			12			24	mA
t_w	Pulse duration	CBA or CAB high		15	15		ns	
		CBA or CAB low		15	15			
		Data high or low		15	15			
t_{su}	Setup time before CAB ↑ or CBA ↑	A or B		15	15		ns	
t_h	Hold time after CAB ↑ or CBA ↑	A or B		0	0		ns	
T_A	Operating free-air temperature	- 55		125	0		70	°C

electrical characteristics over recommended operating free-air temperature range (unless otherwise noted)

PARAMETER	TEST CONDITIONS†	SN54LS651 SN54LS652		SN74LS651 SN74LS652		UNIT	
		MIN	TYP‡	MAX	MIN		TYP‡
V_{IK}	$V_{CC} = \text{MIN}, I_I = - 18 \text{ mA}$	- 1.5		- 1.5		V	
V_{OH}	$V_{CC} = \text{MIN}, V_{IH} = 2 \text{ V}, V_{IL} = \text{MAX},$	$I_{OH} = - 3 \text{ mA}$		2.4	3.4	V	
		$I_{OH} = - 12 \text{ mA}$		2			
		$I_{OH} = - 15 \text{ mA}$		2			
V_{OL}	$V_{CC} = \text{MIN}, V_{IH} = 2 \text{ V}, V_{IL} = \text{MAX},$	$I_{OL} = 12 \text{ mA}$		0.25	0.4	V	
		$I_{OL} = 24 \text{ mA}$		0.35 0.5			
I_I	Control inputs	$V_{CC} = \text{MAX}, V_I = 7 \text{ V}$		0.1		mA	
	A or B ports	$V_{CC} = \text{MAX}, V_I = 5.5 \text{ V}$		0.1			
I_{IH}	Control inputs	$V_{CC} = \text{MAX}, V_I = 2.7 \text{ V}$		20		µA	
	A or B ports¶	$V_{CC} = \text{MAX}, V_I = 2.7 \text{ V}$		20			
I_{IL}	Control inputs	$V_{CC} = \text{MAX}, V_I = 0.4 \text{ V}$		- 0.4		mA	
	A or B ports¶	$V_{CC} = \text{MAX}, V_I = 0.4 \text{ V}$		- 0.4			
I_{OS}^{\S}	$V_{CC} = \text{MAX}, V_O = 0 \text{ V}$	- 40	- 225	- 40	- 225	mA	
I_{CC}	LS651 LS652	$V_{CC} = \text{MAX}$	Outputs high		95	145	mA
			Outputs low		103	165	
			Outputs disabled		103	165	
			Outputs high		95	145	
			Outputs low		103	165	
			Outputs disabled		120	180	

† For conditions shown as MIN or MAX, use the appropriate value specified under recommended operating conditions.

‡ All typical values are at $V_{CC} = 5 \text{ V}, T_A = 25^\circ\text{C}$.

§ Not more than one output should be shorted at a time, and duration of the short-circuit should not exceed one second.

¶ For I/O ports, the parameters I_{IH} and I_{IL} include the off-state output current.



SN54LS651, SN54LS652, SN74LS651, SN74LS652 OCTAL BUS TRANSCEIVERS AND REGISTERS

SDLS191 – JANUARY 1981 – REVISED MARCH 1988

switching characteristics, $V_{CC} = 5\text{ V}$, $T_A = 25^\circ\text{C}$

PARAMETER	FROM (INPUT)	TO (OUTPUT)	TEST CONDITIONS	'LS651			'LS652			UNIT
				MIN	TYP	MAX	MIN	TYP	MAX	
t_{PLH}	Clock	Bus	$R_L = 667\ \Omega$, See Note 2	$C_L = 45\ \text{pF}$	14	24	15	25	ns	
t_{PHL}					23	35	24	36	ns	
t_{PLH}	Bus	Bus			9	18	12	18	ns	
t_{PHL}					20	30	13	20	ns	
t_{PLH}	Select, with bus input high†	Bus			31	47	23	35	ns	
t_{PHL}					22	33	21	32	ns	
t_{PLH}	Select, with bus input low†	Bus			23	35	33	50	ns	
t_{PHL}					19	30	15	23	ns	
t_{PZH}	$\overline{\text{G}}\text{BA}$	A Bus			29	44	30	45	ns	
t_{PZL}		B Bus			40	60	36	54	ns	
t_{PZH}	GAB	A Bus	19	29	20	30	ns			
t_{PZL}		B Bus	26	40	25	38	ns			
t_{PHZ}	$\overline{\text{G}}\text{BA}$	A Bus	25	38	25	38	ns			
t_{PLZ}		B Bus	19	30	19	30	ns			
t_{PHZ}	GAB	A Bus	25	38	25	38	ns			
t_{PLZ}		B Bus	19	30	19	30	ns			

t_{PLH} = propagation delay time, low-to-high-level output.

t_{PHL} = propagation delay time, high-to-low-level output

t_{PZH} = output enable time to high level

t_{PZL} = output enable time to low level

t_{PHZ} = output disable time from high level

t_{PLZ} = output disable time from low level

† These parameters are measured with the internal output state of the storage register opposite to that of the bus input.

NOTE 2: Load circuits and voltage waveforms are shown in Section 1.

schematics of inputs and outputs

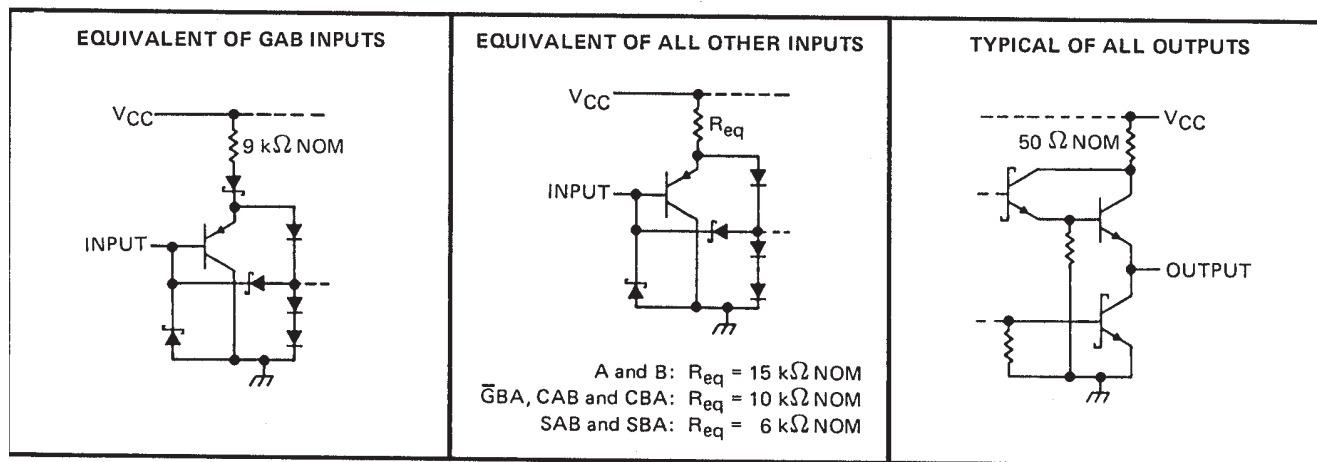

SN54LS653, SN74LS653 OCTAL BUS TRANSCEIVERS AND REGISTERS

SDLS191 – JANUARY 1981 – REVISED MARCH 1988

absolute maximum ratings over operating free-air temperature range (unless otherwise noted)

Supply voltage, V_{CC}	7 V
Input voltage: All inputs and A I/O ports	7 V
B I/O ports	5.5 V
Operating free-air temperature range: SN54LS653	–55°C to 125°C
SN74LS653	0°C to 70°C
Storage temperature range	–65°C to 150°C

recommended operating conditions

		SN54LS653			SN74LS653			UNIT		
		MIN	NOM	MAX	MIN	NOM	MAX			
V_{CC}	Supply voltage	4.5	5	5.5	4.75	5	5.25	V		
V_{IH}	High-level input voltage	2			2			V		
V_{IL}	Low-level input voltage	0.7			0.8			V		
V_{OH}	High-level output voltage	A ports			5.5			V		
I_{OH}	High-level output current	B ports			–12			mA		
I_{OL}	Low-level output current				12			mA		
t_w	Pulse duration	CBA or CAB high			15			ns		
		CBA or CAB low			30					
		Data high or low			30					
t_{su}	Setup time before CAB ↑ or CBA ↑	A or B			15			ns		
t_h	Hold time after CAB ↑ or CBA ↑	A or B			0			ns		
T_A	Operating free-air temperature	–55			125			0	70	°C

electrical characteristics over recommended operating free-air temperature range (unless otherwise noted)

PARAMETER		TEST CONDITIONS†		SN54LS653		SN74LS653		UNIT		
				MIN	TYP‡	MAX	MIN		TYP‡	MAX
V_{IK}		$V_{CC} = \text{MIN}, I_I = -18 \text{ mA}$		–1.5		–1.5		V		
V_{OH}	B ports	$V_{CC} = \text{MIN}, V_{IL} = \text{MAX}$	$V_{IH} = 2 \text{ V}$	$I_{OH} = -3 \text{ mA}$		2.4	3.4	2.4	3.4	V
				$I_{OH} = -12 \text{ mA}$		2				
				$I_{OH} = -15 \text{ mA}$		2				
I_{OH}	A ports	$V_{CC} = \text{MIN}, V_{OH} = 5.5 \text{ V}$		0.1		0.1		mA		
V_{OL}		$V_{CC} = \text{MIN}, V_{IL} = \text{MAX}$	$V_{IH} = 2 \text{ V}$	$I_{OL} = 12 \text{ mA}$		0.25	0.4	0.25	0.4	V
				$I_{OL} = 24 \text{ mA}$		0.35		0.5		
I_I	Control inputs	$V_{CC} = \text{MAX}, V_I = 7 \text{ V}$		0.1		0.1		mA		
	A or B ports	$V_{CC} = \text{MAX}, V_I = 5.5 \text{ V}$		0.1		0.1				
I_{IH}	Control inputs	$V_{CC} = \text{MAX}, V_I = 2.7 \text{ V}$		20		20		μA		
	A or B ports†			20		20				
I_{IL}	Control inputs	$V_{CC} = \text{MAX}, V_I = 0.4 \text{ V}$		–0.4		–0.4		mA		
	A or B ports†			–0.4		–0.4				
$I_{OS}§$	B ports	$V_{CC} = \text{MAX}, V_O = 0 \text{ V}$		–40	–225	–40	–225	mA		
I_{CC}	LS653	$V_{CC} = \text{MAX}$	Outputs high	95	145	95	145	mA		
			Outputs low	103	165	103	165			
			Outputs disabled	103	165	103	165			
	Outputs high		95	145	95	145				
	Outputs low		105	170	105	170				
	Outputs disabled		120	180	120	180				

† For conditions shown as MIN or MAX, use the appropriate value specified under recommended operating conditions.

‡ All typical values are at $V_{CC} = 5 \text{ V}, T_A = 25^\circ\text{C}$.

§ Not more than one output should be shorted at a time, and duration of the short-circuit should not exceed one second.

† For I/O ports, the parameters I_{IH} and I_{IL} include the off-state output current.



SN54LS653, SN74LS653 OCTAL BUS TRANSCEIVERS AND REGISTERS

SDLS191 – JANUARY 1981 – REVISED MARCH 1988

switching characteristics, $V_{CC} = 5\text{ V}$, $T_A = 25^\circ\text{C}$

PARAMETER	FROM (INPUT)	TO (OUTPUT)	TEST CONDITIONS	MIN	TYP	MAX	UNIT
t_{PLH}	CBA	A Bus	$R_L = 667\ \Omega$, $C_L = 45\ \text{pF}$, See Note 2		25	38	ns
t_{PHL}					26	39	
t_{PLH}	CAB	B Bus			15	23	ns
t_{PHL}					24	36	
t_{PLH}	A Bus	B Bus			10	18	ns
t_{PHL}					20	30	
t_{PLH}	B Bus	A Bus			21	32	ns
t_{PHL}					16	24	
t_{PLH}	SBA [†] (with B high)	A Bus			38	57	ns
t_{PHL}					26	39	
t_{PLH}	SBA [†] (with B low)	A Bus			34	51	ns
t_{PHL}					23	35	
t_{PLH}	SAB [†] (with A high)	B Bus			32	48	ns
t_{PHL}					22	33	
t_{PLH}	SAB [†] (with A low)	B Bus			24	36	ns
t_{PHL}					20	30	
t_{PLH}	$\bar{G}BA$	A Bus		23	35	ns	
t_{PHL}				37	55		
t_{PZH}	GAB	B Bus	$R_L = 667\ \Omega$, $C_L = 5\ \text{pF}$, See Note 2		19	29	ns
t_{PZL}					25	38	
t_{PHZ}	GAB	B Bus			26	39	ns
t_{PLZ}					19	29	

[†]These parameters are measured with the internal output state of the storage register opposite to that of the bus input.

NOTE 2: Load circuits and voltage waveforms are shown in Section 1.

schematics of inputs and outputs

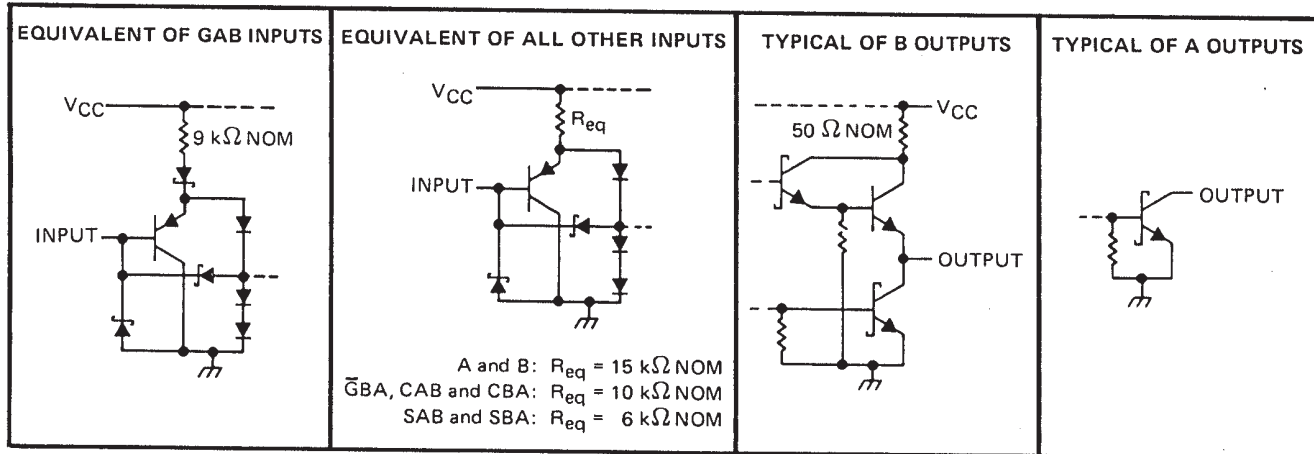

PACKAGING INFORMATION

Orderable Device	Status ⁽¹⁾	Package Type	Package Drawing	Pins	Package Qty	Eco Plan ⁽²⁾	Lead/Ball Finish	MSL Peak Temp ⁽³⁾
SN74LS651DW	OBSOLETE	SOIC	DW	24		TBD	Call TI	Call TI
SN74LS651DWR	OBSOLETE	SOIC	DW	24		TBD	Call TI	Call TI
SN74LS651NT	OBSOLETE	PDIP	NT	24		TBD	Call TI	Call TI
SN74LS652DW	ACTIVE	SOIC	DW	24	25	Green (RoHS & no Sb/Br)	CU NIPDAU	Level-1-260C-UNLIM
SN74LS652DWE4	ACTIVE	SOIC	DW	24	25	Green (RoHS & no Sb/Br)	CU NIPDAU	Level-1-260C-UNLIM
SN74LS652DWR	ACTIVE	SOIC	DW	24	2000	Green (RoHS & no Sb/Br)	CU NIPDAU	Level-1-260C-UNLIM
SN74LS652DWRE4	ACTIVE	SOIC	DW	24	2000	Green (RoHS & no Sb/Br)	CU NIPDAU	Level-1-260C-UNLIM
SN74LS652NT	ACTIVE	PDIP	NT	24	15	Pb-Free (RoHS)	CU NIPDAU	N / A for Pkg Type
SN74LS652NTE4	ACTIVE	PDIP	NT	24	15	Pb-Free (RoHS)	CU NIPDAU	N / A for Pkg Type

⁽¹⁾ The marketing status values are defined as follows:

ACTIVE: Product device recommended for new designs.

LIFEBUY: TI has announced that the device will be discontinued, and a lifetime-buy period is in effect.

NRND: Not recommended for new designs. Device is in production to support existing customers, but TI does not recommend using this part in a new design.

PREVIEW: Device has been announced but is not in production. Samples may or may not be available.

OBSOLETE: TI has discontinued the production of the device.

⁽²⁾ Eco Plan - The planned eco-friendly classification: Pb-Free (RoHS), Pb-Free (RoHS Exempt), or Green (RoHS & no Sb/Br) - please check <http://www.ti.com/productcontent> for the latest availability information and additional product content details.

TBD: The Pb-Free/Green conversion plan has not been defined.

Pb-Free (RoHS): TI's terms "Lead-Free" or "Pb-Free" mean semiconductor products that are compatible with the current RoHS requirements for all 6 substances, including the requirement that lead not exceed 0.1% by weight in homogeneous materials. Where designed to be soldered at high temperatures, TI Pb-Free products are suitable for use in specified lead-free processes.

Pb-Free (RoHS Exempt): This component has a RoHS exemption for either 1) lead-based flip-chip solder bumps used between the die and package, or 2) lead-based die adhesive used between the die and leadframe. The component is otherwise considered Pb-Free (RoHS compatible) as defined above.

Green (RoHS & no Sb/Br): TI defines "Green" to mean Pb-Free (RoHS compatible), and free of Bromine (Br) and Antimony (Sb) based flame retardants (Br or Sb do not exceed 0.1% by weight in homogeneous material)

⁽³⁾ MSL, Peak Temp. -- The Moisture Sensitivity Level rating according to the JEDEC industry standard classifications, and peak solder temperature.

Important Information and Disclaimer:The information provided on this page represents TI's knowledge and belief as of the date that it is provided. TI bases its knowledge and belief on information provided by third parties, and makes no representation or warranty as to the accuracy of such information. Efforts are underway to better integrate information from third parties. TI has taken and continues to take reasonable steps to provide representative and accurate information but may not have conducted destructive testing or chemical analysis on incoming materials and chemicals. TI and TI suppliers consider certain information to be proprietary, and thus CAS numbers and other limited information may not be available for release.

In no event shall TI's liability arising out of such information exceed the total purchase price of the TI part(s) at issue in this document sold by TI to Customer on an annual basis.

IMPORTANT NOTICE

Texas Instruments Incorporated and its subsidiaries (TI) reserve the right to make corrections, modifications, enhancements, improvements, and other changes to its products and services at any time and to discontinue any product or service without notice. Customers should obtain the latest relevant information before placing orders and should verify that such information is current and complete. All products are sold subject to TI's terms and conditions of sale supplied at the time of order acknowledgment.

TI warrants performance of its hardware products to the specifications applicable at the time of sale in accordance with TI's standard warranty. Testing and other quality control techniques are used to the extent TI deems necessary to support this warranty. Except where mandated by government requirements, testing of all parameters of each product is not necessarily performed.

TI assumes no liability for applications assistance or customer product design. Customers are responsible for their products and applications using TI components. To minimize the risks associated with customer products and applications, customers should provide adequate design and operating safeguards.

TI does not warrant or represent that any license, either express or implied, is granted under any TI patent right, copyright, mask work right, or other TI intellectual property right relating to any combination, machine, or process in which TI products or services are used. Information published by TI regarding third-party products or services does not constitute a license from TI to use such products or services or a warranty or endorsement thereof. Use of such information may require a license from a third party under the patents or other intellectual property of the third party, or a license from TI under the patents or other intellectual property of TI.

Reproduction of information in TI data books or data sheets is permissible only if reproduction is without alteration and is accompanied by all associated warranties, conditions, limitations, and notices. Reproduction of this information with alteration is an unfair and deceptive business practice. TI is not responsible or liable for such altered documentation.

Resale of TI products or services with statements different from or beyond the parameters stated by TI for that product or service voids all express and any implied warranties for the associated TI product or service and is an unfair and deceptive business practice. TI is not responsible or liable for any such statements.

Following are URLs where you can obtain information on other Texas Instruments products and application solutions:

Products		Applications	
Amplifiers	amplifier.ti.com	Audio	www.ti.com/audio
Data Converters	dataconverter.ti.com	Automotive	www.ti.com/automotive
DSP	dsp.ti.com	Broadband	www.ti.com/broadband
Interface	interface.ti.com	Digital Control	www.ti.com/digitalcontrol
Logic	logic.ti.com	Military	www.ti.com/military
Power Mgmt	power.ti.com	Optical Networking	www.ti.com/opticalnetwork
Microcontrollers	microcontroller.ti.com	Security	www.ti.com/security
		Telephony	www.ti.com/telephony
		Video & Imaging	www.ti.com/video
		Wireless	www.ti.com/wireless

Mailing Address: Texas Instruments
Post Office Box 655303 Dallas, Texas 75265

Copyright © 2006, Texas Instruments Incorporated