

SN54LS620, SN54LS621, SN74LS620, SN74LS621, SN74LS623 OCTAL BUS TRANSCEIVERS

SDLS185

D2537, AUGUST 1979—REVISED MARCH 1988

- Bidirectional Bus Transceivers in High-Density 20-Pin Packages
- Local Bus-Latch Capability
- Hysteresis at Bus Inputs Improves Noise Margins
- Choice of True or Inverting Logic
- Choice of 3-State or Open-Collector Outputs

DEVICE	OUTPUT	LOGIC
'LS620	3-State	Inverting
'LS621	Open-Collector	True
'LS623	3-State	True

SN54LS620, SN54LS621,
SN54LS622 . . . J PACKAGE
SN74LS620, SN74LS621,
SN74LS623 . . . DW OR N PACKAGE
(TOP VIEW)

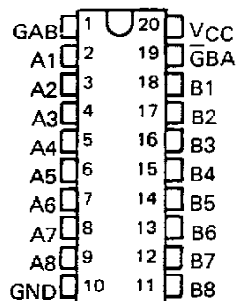

description

These octal bus transceivers are designed for asynchronous two-way communication between data buses. The control function implementation allows for maximum flexibility in timing.

These devices allow data transmission from the A bus to the B bus or from the B bus to the A bus depending upon the logic levels at the enable inputs ($\overline{\text{GBA}}$ and GAB).

The enable inputs can be used to disable the device so that the buses are effectively isolated.

The dual-enable configuration gives the 'LS620, 'LS621, and 'LS623 the capability to store data by simultaneous enabling of $\overline{\text{GBA}}$ and GAB. Each output reinforces its input in this transceiver configuration. Thus, when both control inputs are enabled and all other data sources to the two sets of bus lines are at high impedance, both sets of bus lines (16 in all) will remain at their last states. The 8-bit codes appearing on the two sets of buses will be identical for the 'LS621 and 'LS623 devices or complementary for the 'LS620.

SN54LS620, SN54LS621,
SN54LS622 . . . FK PACKAGE
(TOP VIEW)

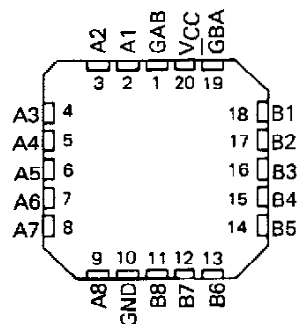

FUNCTION TABLE

ENABLE INPUTS		OPERATION	
$\overline{\text{GBA}}$	GAB	'LS620	'LS621, 'LS623
L	L	B data to A bus	B data to A bus
H	H	A data to B bus	A data to B bus
H	L	Isolation	Isolation
L	H	$\overline{\text{B}}$ data to A bus, $\overline{\text{A}}$ data to B bus	B data to A bus, A data to B bus

H = high level, L = low level

absolute maximum ratings over operating free-air temperature range (unless otherwise noted)

Supply voltage, V_{CC} (see Note 1)	7 V
Input voltage	7 V
Off-state output voltage	5.5 V
Operating free-air temperature range: SN54LS'	-55°C to 125°C
SN74LS'	0°C to 70°C
Storage temperature range	-65°C to 150°C

NOTE 1: Voltage values are with respect to network ground terminal.

PRODUCTION DATA documents contain information current as of publication date. Products conform to specifications per the terms of Texas Instruments standard warranty. Production processing does not necessarily include testing of all parameters.

TEXAS
INSTRUMENTS

POST OFFICE BOX 655012 • DALLAS, TEXAS 75265

SN54LS620, SN54LS621, SN74LS620, SN74LS621, SN74LS623 OCTAL BUS TRANSCEIVERS

logic symbols†

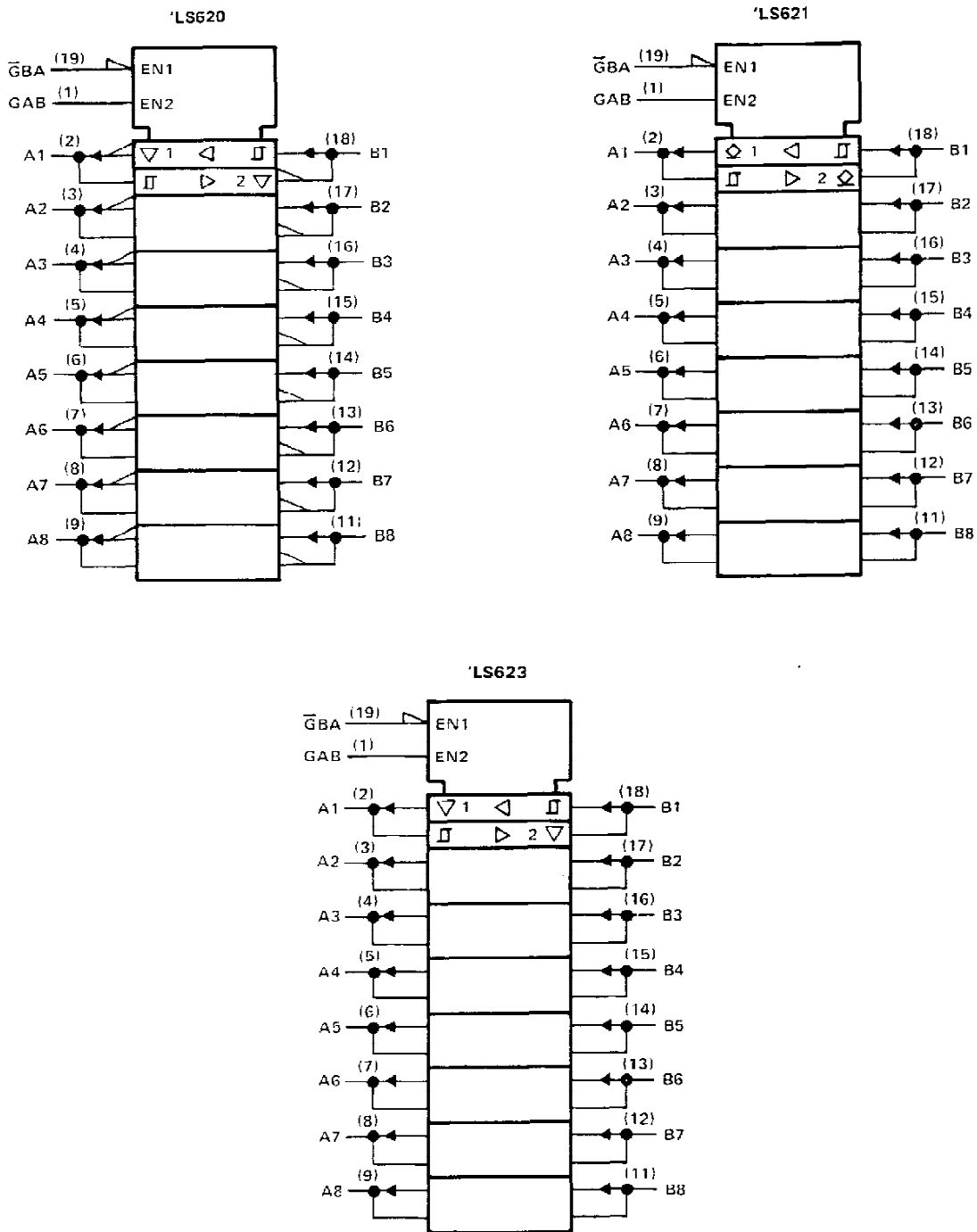

† These symbols are in accordance with ANSI/IEEE Std 91-1984 and IEC Publication 617-12. Pin numbers shown are for DW, J, and N packages.

**SN54LS620, SN54LS621,
SN74LS620, SN74LS621, SN74LS623
OCTAL BUS TRANSCEIVERS**

logic diagrams (positive logic)

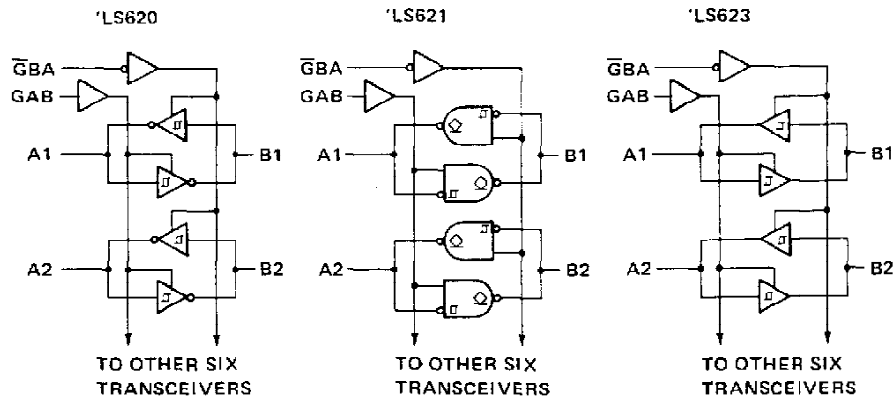

schematics of inputs and outputs

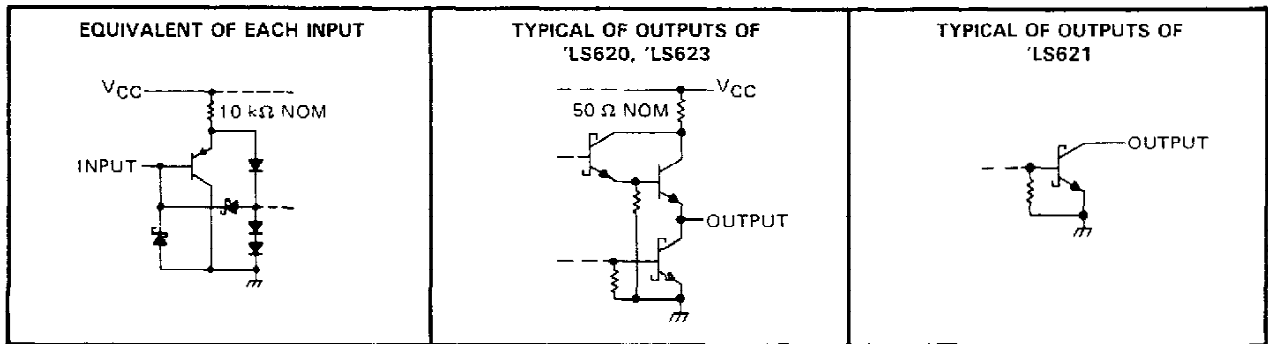

**TEXAS
INSTRUMENTS**

POST OFFICE BOX 655012 • DALLAS, TEXAS 75285

SN54LS620, SN74LS620, SN74LS623 OCTAL BUS TRANSCEIVERS WITH 3-STATE OUTPUTS

recommended operating conditions

PARAMETER	SN54LS620			SN74LS620 SN74LS623			UNIT
	MIN	NOM	MAX	MIN	NOM	MAX	
Supply voltage, V_{CC} (see Note 1)	4.5	5	5.5	4.75	5	5.25	V
High-level output current, I_{OH}			-12			-15	mA
Low-level output current, I_{OL}			12			24	mA
Operating free-air temperature, T_A	-55		125	0		70	°C

NOTE 1: Voltage values are with respect to network ground terminal.

electrical characteristics over recommended operating free-air temperature range (unless otherwise noted)

PARAMETER	TEST CONDITIONS†	SN54LS620			SN74LS620 SN74LS623			UNIT
		MIN	TYP‡	MAX	MIN	TYP‡	MAX	
V_{IH} High-level input voltage		2		0.5	2		0.6	V
V_{IL} Low-level input voltage				0.5			0.6	V
V_{IK} Input clamp voltage	$V_{CC} = \text{MIN}, I_I = -18 \text{ mA}$			-1.5			-1.5	V
Hysteresis ($V_{T+} - V_{T-}$) A or B input	$V_{CC} = \text{MIN}$	0.1	0.4		0.2	0.4		V
V_{OH} High-level output voltage	$V_{CC} = \text{MIN}, V_{IH} = 2 \text{ V}, V_{IL} = V_{IL \text{ max}}, I_{OH} = -3 \text{ mA}$	2.4	3.4		2.4	3.4		V
	$I_{OH} = \text{MAX}$	2			2			V
V_{OL} Low-level output voltage	$V_{CC} = \text{MIN}, V_{IH} = 2 \text{ V}, V_{IL} = V_{IL \text{ max}}, I_{OL} = 12 \text{ mA}$		0.25	0.4		0.25	0.4	V
	$I_{OL} = 24 \text{ mA}$					0.35	0.5	V
I_{OZH} Off-state output current, high-level voltage applied	$V_{CC} = \text{MAX}, V_O = 2.7 \text{ V}, \bar{G}$ at 2 V,			20			20	µA
I_{OZL} Off-state output current, low-level voltage applied	$V_{CC} = \text{MAX}, V_O = 0.4 \text{ V}, \bar{G}$ at 2 V,			-400			-400	µA
I_I Input current at maximum input voltage	A or B			0.1			0.1	mA
	GBA or GAB			0.1			0.1	mA
I_{IH} High-level input current	$V_{CC} = \text{MAX}, V_I = 2.7 \text{ V}$			20			20	µA
I_{IL} Low-level input current	$V_{CC} = \text{MAX}, V_I = 0.4 \text{ V}$			-0.4			-0.4	mA
I_{OS} Short-circuit output current §	$V_{CC} = \text{MAX}$	-40		-225	-40		-225	mA
I_{CC} Total supply current	Outputs high		48	70		48	70	mA
	Outputs low		62	90		62	90	mA
	Outputs at Hi-Z		64	95		64	95	mA

† For conditions shown as MIN or MAX use the appropriate value specified under recommended operating conditions.

‡ All typical values are at $V_{CC} = 5 \text{ V}, T_A = 25^\circ \text{C}$.

§ Not more than one output should be shorted at a time, and duration of the short-circuit should not exceed one second.

switching characteristics at $V_{CC} = 5 \text{ V}, T_A = 25^\circ \text{C}$

PARAMETER	FROM (INPUT)	TO (OUTPUT)	TEST CONDITIONS	'LS620			SN74LS623			UNIT
				MIN	TYP	MAX	MIN	TYP	MAX	
t_{PLH} Propagation delay time, low-to-high-level output	A	B	$C_L = 45 \text{ pF}, R_L = 667 \Omega,$ See Note 2	6	10		8	15	ns	
	B	A		6	10		8	15		
t_{PHL} Propagation delay time, high-to-low-level output	A	B		8	15		11	15	ns	
	B	A		8	15		11	15		
t_{PZL} Output enable time to low level	\bar{G} BA	A	See Note 2	31	40		31	40	ns	
	GAB	B		31	40		31	40		
t_{PZH} Output enable time to high level	\bar{G} BA	A		23	40		26	40	ns	
	GAB	B		23	40		26	40		
t_{PLZ} Output disable time from low level	\bar{G} BA	A	$C_L = 5 \text{ pF}, R_L = 667 \Omega,$ See Note 2	15	25		15	25	ns	
	GAB	B		15	25		15	25		
t_{PHZ} Output disable time from high level	\bar{G} BA	A		15	25		15	25	ns	
	GAB	B		15	25		15	25		

t_{PLH} = Propagation delay time, low-to-high-level output

t_{PHL} = Propagation delay time, high-to-low-level output

t_{PZH} = Output enable time to high level

NOTE 2: Load circuits and voltage waveforms are shown in Section 1.

t_{PZL} = Output enable time to low level

t_{PHZ} = Output disable time from high level

t_{PLZ} = Output disable time from low level

TEXAS
INSTRUMENTS

POST OFFICE BOX 655012 • DALLAS, TEXAS 75265

SN54LS621, SN74LS621 OCTAL BUS TRANSCEIVERS WITH OPEN-COLLECTOR OUTPUTS

recommended operating conditions

PARAMETER	SN54LS621			SN74LS621			UNIT
	MIN	NOM	MAX	MIN	NOM	MAX	
Supply voltage, V_{CC} (see Note 1)	4.5	5	5.5	4.75	5	5.25	V
High-level output voltage, V_{OH}			5.5			5.5	V
Low-level output current, I_{OL}			12			24	mA
Operating free-air temperature, T_A	-55		125	0		70	°C

NOTE 1: Voltage values are with respect to network ground terminal.

electrical characteristics over recommended operating free-air temperature range (unless otherwise noted)

PARAMETER		TEST CONDITIONS†	SN54LS621			SN74LS621			UNIT	
			MIN	TYP‡	MAX	MIN	TYP‡	MAX		
V_{IH}	High-level input voltage		2			2			V	
V_{IL}	Low-level input voltage				0.5			0.6	V	
V_{IK}	Input clamp voltage	$V_{CC} = \text{MIN}, I_I = -18 \text{ mA}$			-1.5			-1.5	V	
	Hysteresis ($V_{T+} - V_{T-}$) A or B input	$V_{CC} = \text{MIN}$	0.1	0.4		0.2	0.4		V	
I_{OH}	High-level output current	$V_{CC} = \text{MIN}, V_{IH} = 2 \text{ V}, V_{IL} = V_{IL \text{ max}}, V_{OH} = 5.5 \text{ V}$			100			100	μA	
V_{OL}	Low-level output voltage	$V_{CC} = \text{MIN}, I_{OL} = 12 \text{ mA}$	0.25	0.4		0.25	0.4		V	
		$V_{CC} = \text{MIN}, I_{OL} = 24 \text{ mA}$				0.35	0.5			
I_I	Input current at maximum input voltage	A or B			0.1			0.1	mA	
		GAB or $\bar{G}BA$	$V_{CC} = \text{MAX}, V_I = 7 \text{ V}$			0.1		0.1		
I_{IH}	High-level input current	$V_{CC} = \text{MAX}, V_I = 2.7 \text{ V}$			20			20	μA	
I_{IL}	Low-level input current	$V_{CC} = \text{MAX}, V_I = 0.4 \text{ V}$			-0.4			-0.4	mA	
I_{CC}	Total supply current	Outputs high			48	70		48	70	mA
		Outputs low	$V_{CC} = \text{MAX},$ Outputs open			62	90		62	

†For conditions shown as MIN or MAX use the appropriate value specified under recommended operating conditions.

‡All typical values are at $V_{CC} = 5 \text{ V}, T_A = 25^\circ\text{C}$.

switching characteristics, $V_{CC} = 5 \text{ V}, T_A = 25^\circ\text{C}$

PARAMETER	FROM (INPUT)	TO (OUTPUT)	TEST CONDITIONS	'LS621			UNIT
				MIN	TYP	MAX	
t_{PLH}	Propagation delay time, low-to-high-level output	A	$C_L = 45 \text{ pF}, R_L = 667 \Omega,$ See Note 2		17	25	ns
		B			17	25	
t_{PHL}	Propagation delay time, high-to-low-level output	A			16	25	ns
		B			16	25	
t_{PLH}	Output disable time from low level	$\bar{G}BA$			23	40	ns
		GAB			25	40	
t_{PHL}	Output enable time from high level	$\bar{G}BA$			34	50	ns
		GAB			37	50	

t_{PLH} = Propagation delay time, low-to-high-level output

t_{PHL} = Propagation delay time, high-to-low-level output

NOTE 2: Load circuits and voltage waveforms are shown in Section 1.

TEXAS INSTRUMENTS

POST OFFICE BOX 655012 • DALLAS, TEXAS 75265

IMPORTANT NOTICE

Texas Instruments (TI) reserves the right to make changes to its products or to discontinue any semiconductor product or service without notice, and advises its customers to obtain the latest version of relevant information to verify, before placing orders, that the information being relied on is current.

TI warrants performance of its semiconductor products and related software to the specifications applicable at the time of sale in accordance with TI's standard warranty. Testing and other quality control techniques are utilized to the extent TI deems necessary to support this warranty. Specific testing of all parameters of each device is not necessarily performed, except those mandated by government requirements.

Certain applications using semiconductor products may involve potential risks of death, personal injury, or severe property or environmental damage ("Critical Applications").

TI SEMICONDUCTOR PRODUCTS ARE NOT DESIGNED, INTENDED, AUTHORIZED, OR WARRANTED TO BE SUITABLE FOR USE IN LIFE-SUPPORT APPLICATIONS, DEVICES OR SYSTEMS OR OTHER CRITICAL APPLICATIONS.

Inclusion of TI products in such applications is understood to be fully at the risk of the customer. Use of TI products in such applications requires the written approval of an appropriate TI officer. Questions concerning potential risk applications should be directed to TI through a local SC sales office.

In order to minimize risks associated with the customer's applications, adequate design and operating safeguards should be provided by the customer to minimize inherent or procedural hazards.

TI assumes no liability for applications assistance, customer product design, software performance, or infringement of patents or services described herein. Nor does TI warrant or represent that any license, either express or implied, is granted under any patent right, copyright, mask work right, or other intellectual property right of TI covering or relating to any combination, machine, or process in which such semiconductor products or services might be or are used.

IMPORTANT NOTICE

Texas Instruments (TI) reserves the right to make changes to its products or to discontinue any semiconductor product or service without notice, and advises its customers to obtain the latest version of relevant information to verify, before placing orders, that the information being relied on is current.

TI warrants performance of its semiconductor products and related software to the specifications applicable at the time of sale in accordance with TI's standard warranty. Testing and other quality control techniques are utilized to the extent TI deems necessary to support this warranty. Specific testing of all parameters of each device is not necessarily performed, except those mandated by government requirements.

Certain applications using semiconductor products may involve potential risks of death, personal injury, or severe property or environmental damage ("Critical Applications").

TI SEMICONDUCTOR PRODUCTS ARE NOT DESIGNED, INTENDED, AUTHORIZED, OR WARRANTED TO BE SUITABLE FOR USE IN LIFE-SUPPORT APPLICATIONS, DEVICES OR SYSTEMS OR OTHER CRITICAL APPLICATIONS.

Inclusion of TI products in such applications is understood to be fully at the risk of the customer. Use of TI products in such applications requires the written approval of an appropriate TI officer. Questions concerning potential risk applications should be directed to TI through a local SC sales office.

In order to minimize risks associated with the customer's applications, adequate design and operating safeguards should be provided by the customer to minimize inherent or procedural hazards.

TI assumes no liability for applications assistance, customer product design, software performance, or infringement of patents or services described herein. Nor does TI warrant or represent that any license, either express or implied, is granted under any patent right, copyright, mask work right, or other intellectual property right of TI covering or relating to any combination, machine, or process in which such semiconductor products or services might be or are used.

TAPE AND REEL INFORMATION



QUADRANT ASSIGNMENTS FOR PIN 1 ORIENTATION IN TAPE

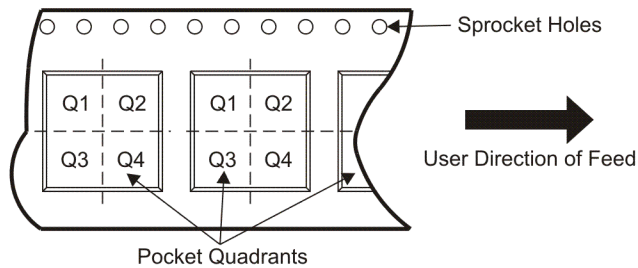

*All dimensions are nominal

Device	Package Type	Package Drawing	Pins	SPQ	Reel Diameter (mm)	Reel Width W1 (mm)	A0 (mm)	B0 (mm)	K0 (mm)	P1 (mm)	W (mm)	Pin1 Quadrant
SN74LS623DWR	SOIC	DW	20	2000	330.0	24.4	10.8	13.0	2.7	12.0	24.0	Q1
SN74LS623NSR	SO	NS	20	2000	330.0	24.4	8.2	13.0	2.5	12.0	24.0	Q1

TAPE AND REEL BOX DIMENSIONS



*All dimensions are nominal

Device	Package Type	Package Drawing	Pins	SPQ	Length (mm)	Width (mm)	Height (mm)
SN74LS623DWR	SOIC	DW	20	2000	346.0	346.0	41.0
SN74LS623NSR	SO	NS	20	2000	346.0	346.0	41.0

IMPORTANT NOTICE

Texas Instruments Incorporated and its subsidiaries (TI) reserve the right to make corrections, modifications, enhancements, improvements, and other changes to its products and services at any time and to discontinue any product or service without notice. Customers should obtain the latest relevant information before placing orders and should verify that such information is current and complete. All products are sold subject to TI's terms and conditions of sale supplied at the time of order acknowledgment.

TI warrants performance of its hardware products to the specifications applicable at the time of sale in accordance with TI's standard warranty. Testing and other quality control techniques are used to the extent TI deems necessary to support this warranty. Except where mandated by government requirements, testing of all parameters of each product is not necessarily performed.

TI assumes no liability for applications assistance or customer product design. Customers are responsible for their products and applications using TI components. To minimize the risks associated with customer products and applications, customers should provide adequate design and operating safeguards.

TI does not warrant or represent that any license, either express or implied, is granted under any TI patent right, copyright, mask work right, or other TI intellectual property right relating to any combination, machine, or process in which TI products or services are used. Information published by TI regarding third-party products or services does not constitute a license from TI to use such products or services or a warranty or endorsement thereof. Use of such information may require a license from a third party under the patents or other intellectual property of the third party, or a license from TI under the patents or other intellectual property of TI.

Reproduction of TI information in TI data books or data sheets is permissible only if reproduction is without alteration and is accompanied by all associated warranties, conditions, limitations, and notices. Reproduction of this information with alteration is an unfair and deceptive business practice. TI is not responsible or liable for such altered documentation. Information of third parties may be subject to additional restrictions.

Resale of TI products or services with statements different from or beyond the parameters stated by TI for that product or service voids all express and any implied warranties for the associated TI product or service and is an unfair and deceptive business practice. TI is not responsible or liable for any such statements.

TI products are not authorized for use in safety-critical applications (such as life support) where a failure of the TI product would reasonably be expected to cause severe personal injury or death, unless officers of the parties have executed an agreement specifically governing such use. Buyers represent that they have all necessary expertise in the safety and regulatory ramifications of their applications, and acknowledge and agree that they are solely responsible for all legal, regulatory and safety-related requirements concerning their products and any use of TI products in such safety-critical applications, notwithstanding any applications-related information or support that may be provided by TI. Further, Buyers must fully indemnify TI and its representatives against any damages arising out of the use of TI products in such safety-critical applications.

TI products are neither designed nor intended for use in military/aerospace applications or environments unless the TI products are specifically designated by TI as military-grade or "enhanced plastic." Only products designated by TI as military-grade meet military specifications. Buyers acknowledge and agree that any such use of TI products which TI has not designated as military-grade is solely at the Buyer's risk, and that they are solely responsible for compliance with all legal and regulatory requirements in connection with such use.

TI products are neither designed nor intended for use in automotive applications or environments unless the specific TI products are designated by TI as compliant with ISO/TS 16949 requirements. Buyers acknowledge and agree that, if they use any non-designated products in automotive applications, TI will not be responsible for any failure to meet such requirements.

Following are URLs where you can obtain information on other Texas Instruments products and application solutions:

Products

Amplifiers	amplifier.ti.com
Data Converters	dataconverter.ti.com
DLP® Products	www.dlp.com
DSP	dsp.ti.com
Clocks and Timers	www.ti.com/clocks
Interface	interface.ti.com
Logic	logic.ti.com
Power Mgmt	power.ti.com
Microcontrollers	microcontroller.ti.com
RFID	www.ti-rfid.com
RF/IF and ZigBee® Solutions	www.ti.com/lprf

Applications

Audio	www.ti.com/audio
Automotive	www.ti.com/automotive
Broadband	www.ti.com/broadband
Digital Control	www.ti.com/digitalcontrol
Medical	www.ti.com/medical
Military	www.ti.com/military
Optical Networking	www.ti.com/opticalnetwork
Security	www.ti.com/security
Telephony	www.ti.com/telephony
Video & Imaging	www.ti.com/video
Wireless	www.ti.com/wireless

Mailing Address: Texas Instruments, Post Office Box 655303, Dallas, Texas 75265
Copyright © 2009, Texas Instruments Incorporated