

SN54LS590, SN54LS591, SN74LS590, SN74LS591 8-BIT BINARY COUNTERS WITH OUTPUT REGISTERS

SDLS003

D2632, JANUARY 1981 — REVISED MARCH 1988

- 8-Bit Counter with Register
- Parallel Register Outputs
- Choice of 3-State ('LS590) or Open-Collector ('LS591) Register Outputs
- Guaranteed Counter Frequency: DC to 20 MHz

SN54LS590, SN54LS591 . . . J OR W PACKAGE
SN74LS590, SN74LS591 . . . N PACKAGE

(TOP VIEW)

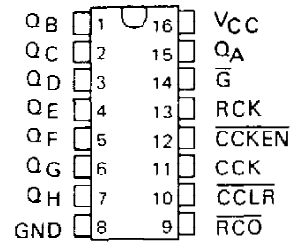

description

These devices each contain an 8-bit binary counter that feeds an 8-bit storage register. The storage register has parallel outputs. Separate clocks are provided for both the binary counter and storage register. The binary counter features a direct clear input \overline{CCLR} and a count enable input \overline{CCKEN} . For cascading, a ripple carry output \overline{RCO} is provided. Expansion is easily accomplished for two stages by connecting \overline{RCO} of the first stage to \overline{CCKEN} of the second stage. Cascading for larger count chains can be accomplished by connecting \overline{RCO} of each stage to CCK of the following stage.

Both the counter and register clocks are positive-edge triggered. If the user wishes to connect both clocks together, the counter state will always be one count ahead of the register. Internal circuitry prevents clocking from the clock enable.

SN54LS590, SN54LS591 . . . FK PACKAGE

(TOP VIEW)

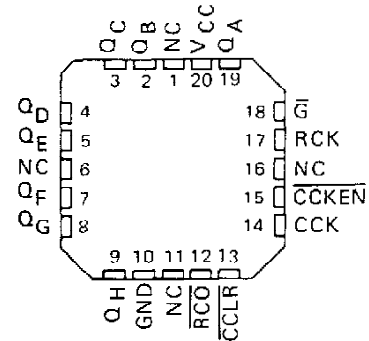

NC - No internal connection

schematics of inputs and outputs

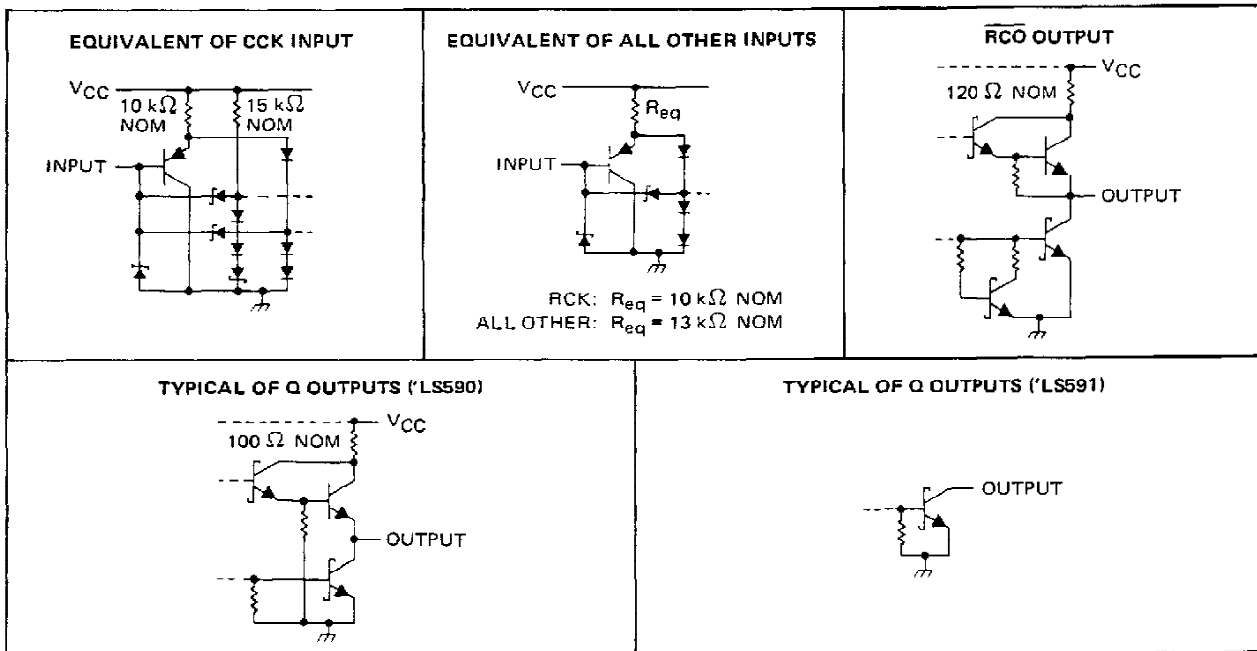

PRODUCTION DATA documents contain information current as of publication date. Products conform to specifications per the terms of Texas Instruments standard warranty. Production processing does not necessarily include testing of all parameters.

TEXAS
INSTRUMENTS

POST OFFICE BOX 655012 • DALLAS, TEXAS 75265

SN54LS590, SN54LS591, SN74LS590, SN74LS591
8-BIT BINARY COUNTERS WITH OUTPUT REGISTERS

logic diagram (positive logic)

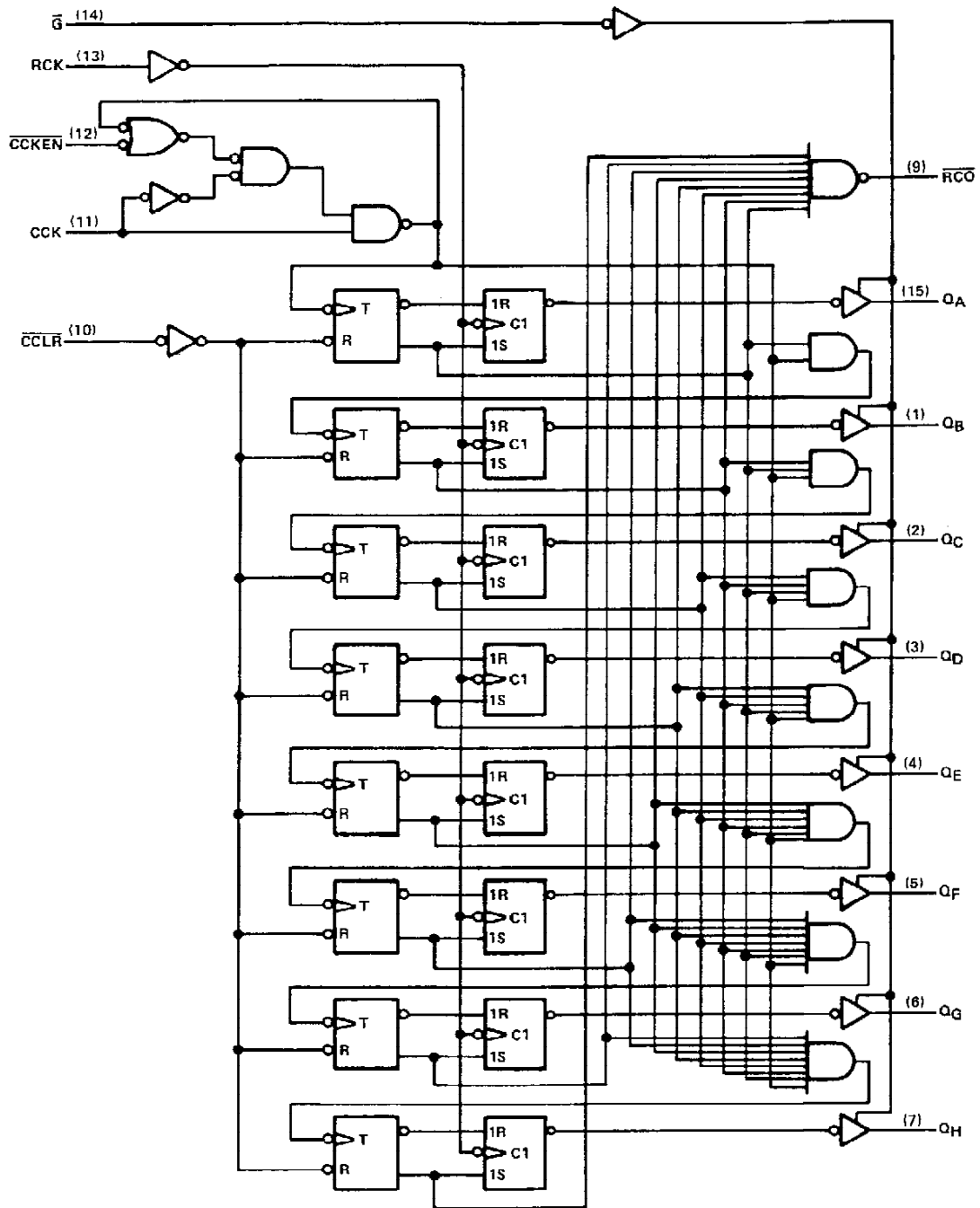

Pin numbers shown are for J, N and W packages.

TEXAS
INSTRUMENTS

POST OFFICE BOX 655012 • DALLAS, TEXAS 75265

SN54LS590, SN54LS591, SN74LS590, SN74LS591 8-BIT BINARY COUNTERS WITH OUTPUT REGISTERS

logic symbols †

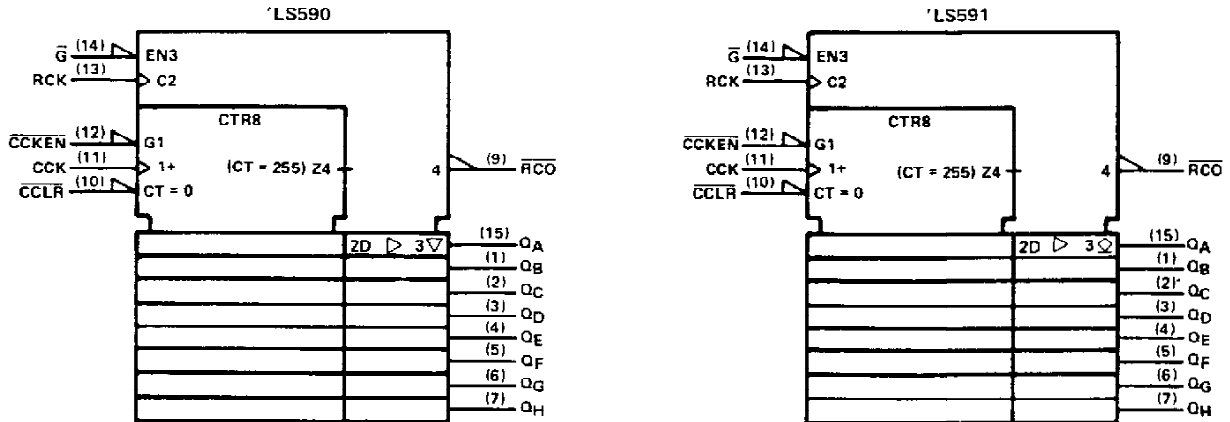

†These symbols are in accordance with ANSI/IEEE Std. 91-1984 and IEC Publication 617-12. Pin numbers shown are for J, N, and W packages.

absolute maximum ratings over operating free-air temperature range (unless otherwise noted)

Supply voltage, V_{CC} (see Note 1)	7 V
Input voltage	7 V
Off-state output voltage	5.5 V
Operating free-air temperature range: SN54LS590, SN54LS591	-55°C to 125°C
SN74LS590, SN74LS591	0°C to 70°C
Storage temperature range	-65°C to 150°C

NOTE 1: Voltage values are with respect to the network ground terminal.

recommended operating conditions

		SN54LS*			SN74LS*			UNIT
		MIN	NOM	MAX	MIN	NOM	MAX	
V_{CC}	Supply voltage	4.5	5	5.5	4.75	5	5.25	V
V_{IH}	High-level input voltage	2			2			V
V_{IL}	Low-level input voltage	0.7			0.8			V
V_{OH}	High-level output voltage	Q, 'LS591 only		5.5	5.5		V	
I_{OH}	High-level output current	RCO		-1	-1		mA	
		Q, 'LS590 only		-1	-2.6			
I_{OL}	Low-level output current	RCO		8	16		mA	
		Q		12	24			
f_{CCK}	Counter clock frequency	0	20	0	20	MHz		
f_{RCK}	Register clock frequency	0	25	0	25	MHz		
$t_w(CCK)$	Duration of counter clock pulse	25			25			ns
$t_w(\overline{CCLR})$	Duration of counter clear pulse	20			20			ns
$t_w(RCK)$	Duration of register clock pulse	20			20			ns
t_{su}	Setup time	CCKEN low before CCK ↑		20	20		ns	
		CCLR inactive before CCK ↑		20	20			
		CCK before RCK ↑ (see Note 2)		40	40			
t_h	Hold time	CCKEN low after CCK ↑		0	0		ns	
T_A	Operating free-air temperature	-55	125	0	70	$^{\circ}\text{C}$		

NOTE 2: This setup time ensures the register will see stable data from the counter outputs. The clocks may be tied together in which case the register state will be one clock pulse behind the counter.

TEXAS
INSTRUMENTS

POST OFFICE BOX 655012 • DALLAS, TEXAS 75265

SN54LS590, SN54LS591, SN74LS590, SN74LS591

8-BIT BINARY COUNTERS WITH OUTPUT REGISTERS

electrical characteristics over recommended operating free-air temperature range (unless otherwise noted)

PARAMETER	TEST CONDITIONS†	SN54LS*			SN74LS*			UNIT		
		MIN	TYP‡	MAX	MIN	TYP‡	MAX			
V _{IK}	V _{CC} = MIN, I _I = -18 mA			-1.5			-1.5	V		
V _{OH}	'LS590 Q RCO	V _{CC} = MIN, V _{IH} = 2V, V _{IL} = MAX	I _{OH} = -1 mA	2.4	3.2			V		
			I _{OH} = -2.6 mA			2.4	3.1			
I _{OH}	'LS591 Q	V _{CC} = MIN, V _{IH} = 2V, V _{IL} = MAX	V _{OH} = 5.5V					mA		
						0.1			0.1	
V _{OL}	Q RCO	V _{CC} = MIN, V _{IH} = 2V, V _{IL} = MAX	I _{OL} = 12 mA	0.25	0.4			V		
			I _{OL} = 24 mA			0.25	0.4			
			I _{OL} = 8 mA			0.25	0.4			
			I _{OL} = 16 mA			0.35	0.5			
I _{OZH}	'LS590 Q	V _{CC} = MAX, V _O = 2.7 V	V _{IH} = 2V, V _{IL} = MAX			20		20	μA	
I _{OZL}	'LS590 Q	V _{CC} = MAX, V _O = 0.4 V	V _{IH} = 2V, V _{IL} = MAX			-20		-20	μA	
I _I		V _{CC} = MAX, V _I = 7 V				0.1		0.1	mA	
I _{IH}		V _{CC} = MAX, V _I = 2.7 V				20		20	μA	
I _{IL}	CCK	V _{CC} = MAX, V _I = 0.4 V				-0.8		-0.8	mA	
	All others					-0.2		-0.2		
I _{OS} §	'LS590 Q	V _{CC} = MAX, V _O = 0 V				-30		-130	mA	
	RCO					-20		-100		
I _{CC}	'LS590	V _{CC} = MAX, All possible inputs grounded, All outputs open	I _{CCH}	33	55			33	55	mA
			I _{CCL}	44	65			44	65	
			I _{CCZ}	46	65			46	65	
	'LS591		I _{CCH}	35	55			35	55	
			I _{CCL}	42	65			42	65	

† For conditions shown as MIN or MAX, use the appropriate value specified under recommended operating conditions.

‡ All typical values are at V_{CC} = 5 V, T_A = 25°C

§ Not more than one output should be shorted at a time and the duration of the short-circuit should not exceed one second.

switching characteristics, V_{CC} = 5 V, T_A = 25°C (see note 3)

PARAMETER	FROM (INPUT)	TO (OUTPUT)	TEST CONDITIONS	'LS590			'LS591			UNIT
				MIN	TYP	MAX	MIN	TYP	MAX	
f _{max}	RCK	Q	R _L = 667 Ω, C _L = 45 pF	20	35		20	35		MHz
t _{PLH}	CCK↑	RCO	R _L = 1 kΩ, C _L = 30 pF		14	22		16	24	ns
t _{PHL}	CCK↑	RCO			20	30		25	38	ns
t _{PLH}	CCLR↓	RCO	R _L = 667 Ω, C _L = 45 pF		30	45		32	48	ns
t _{PLH}	RCK↑	Q			12	18		25	38	ns
t _{PHL}	RCK↑	Q			22	33		28	42	ns
t _{PZH}	G↓	Q			25	38				ns
t _{PZL}	G↓	Q			30	45				ns
t _{PHZ}	G↑	Q			20	30				ns
t _{PLZ}	G↑	Q	R _L = 667 Ω, C _L = 5 pF		25	38				ns
t _{PLH}	G↑	Q	R _L = 667 Ω, C _L = 45 pF					34	50	ns
t _{PHL}	G↓	Q						32	48	ns

NOTE 3: Load circuits and voltage waveforms are shown in Section 1.

TEXAS
INSTRUMENTS

POST OFFICE BOX 655012 • DALLAS, TEXAS 75285

IMPORTANT NOTICE

Texas Instruments (TI) reserves the right to make changes to its products or to discontinue any semiconductor product or service without notice, and advises its customers to obtain the latest version of relevant information to verify, before placing orders, that the information being relied on is current.

TI warrants performance of its semiconductor products and related software to the specifications applicable at the time of sale in accordance with TI's standard warranty. Testing and other quality control techniques are utilized to the extent TI deems necessary to support this warranty. Specific testing of all parameters of each device is not necessarily performed, except those mandated by government requirements.

Certain applications using semiconductor products may involve potential risks of death, personal injury, or severe property or environmental damage ("Critical Applications").

TI SEMICONDUCTOR PRODUCTS ARE NOT DESIGNED, INTENDED, AUTHORIZED, OR WARRANTED TO BE SUITABLE FOR USE IN LIFE-SUPPORT APPLICATIONS, DEVICES OR SYSTEMS OR OTHER CRITICAL APPLICATIONS.

Inclusion of TI products in such applications is understood to be fully at the risk of the customer. Use of TI products in such applications requires the written approval of an appropriate TI officer. Questions concerning potential risk applications should be directed to TI through a local SC sales office.

In order to minimize risks associated with the customer's applications, adequate design and operating safeguards should be provided by the customer to minimize inherent or procedural hazards.

TI assumes no liability for applications assistance, customer product design, software performance, or infringement of patents or services described herein. Nor does TI warrant or represent that any license, either express or implied, is granted under any patent right, copyright, mask work right, or other intellectual property right of TI covering or relating to any combination, machine, or process in which such semiconductor products or services might be or are used.

PACKAGING INFORMATION

Orderable Device	Status ⁽¹⁾	Package Type	Package Drawing	Pins	Package Qty	Eco Plan ⁽²⁾	Lead/Ball Finish	MSL Peak Temp ⁽³⁾
5962-87517012A	ACTIVE	LCCC	FK	20	1	TBD	Call TI	Level-NC-NC-NC
5962-8751701EA	ACTIVE	CDIP	J	16	1	TBD	Call TI	Level-NC-NC-NC
5962-8751701EA	ACTIVE	CDIP	J	16	1	TBD	Call TI	Level-NC-NC-NC
5962-8751701FA	ACTIVE	CFP	W	16	1	TBD	Call TI	Level-NC-NC-NC
5962-8751701FA	ACTIVE	CFP	W	16	1	TBD	Call TI	Level-NC-NC-NC
SN54LS590J	ACTIVE	CDIP	J	16	1	TBD	Call TI	Level-NC-NC-NC
SN54LS590J	ACTIVE	CDIP	J	16	1	TBD	Call TI	Level-NC-NC-NC
SN74LS590D	ACTIVE	SOIC	D	16	40	Pb-Free (RoHS)	CU NIPDAU	Level-2-250C-1 YEAR
SN74LS590D	ACTIVE	SOIC	D	16	40	Pb-Free (RoHS)	CU NIPDAU	Level-2-250C-1 YEAR
SN74LS590DE4	ACTIVE	SOIC	D	16	40	Pb-Free (RoHS)	CU NIPDAU	Level-2-250C-1 YEAR
SN74LS590DE4	ACTIVE	SOIC	D	16	40	Pb-Free (RoHS)	CU NIPDAU	Level-2-250C-1 YEAR
SN74LS590DR	ACTIVE	SOIC	D	16	2500	Pb-Free (RoHS)	CU NIPDAU	Level-2-250C-1 YEAR
SN74LS590DR	ACTIVE	SOIC	D	16	2500	Pb-Free (RoHS)	CU NIPDAU	Level-2-250C-1 YEAR
SN74LS590DRE4	ACTIVE	SOIC	D	16	2500	Pb-Free (RoHS)	CU NIPDAU	Level-2-250C-1 YEAR
SN74LS590DRE4	ACTIVE	SOIC	D	16	2500	Pb-Free (RoHS)	CU NIPDAU	Level-2-250C-1 YEAR
SN74LS590N	ACTIVE	PDIP	N	16	25	Pb-Free (RoHS)	CU NIPDAU	Level-NC-NC-NC
SN74LS590N	ACTIVE	PDIP	N	16	25	Pb-Free (RoHS)	CU NIPDAU	Level-NC-NC-NC
SN74LS590N3	OBSOLETE	PDIP	N	16		TBD	Call TI	Call TI
SN74LS590N3	OBSOLETE	PDIP	N	16		TBD	Call TI	Call TI
SN74LS590NE4	ACTIVE	PDIP	N	16	25	Pb-Free (RoHS)	CU NIPDAU	Level-NC-NC-NC
SN74LS590NE4	ACTIVE	PDIP	N	16	25	Pb-Free (RoHS)	CU NIPDAU	Level-NC-NC-NC
SN74LS590NSR	ACTIVE	SO	NS	16	2000	Pb-Free (RoHS)	CU NIPDAU	Level-2-260C-1 YEAR/ Level-1-235C-UNLIM
SN74LS590NSR	ACTIVE	SO	NS	16	2000	Pb-Free (RoHS)	CU NIPDAU	Level-2-260C-1 YEAR/ Level-1-235C-UNLIM
SN74LS590NSRE4	ACTIVE	SO	NS	16	2000	Pb-Free (RoHS)	CU NIPDAU	Level-2-260C-1 YEAR/ Level-1-235C-UNLIM
SN74LS590NSRE4	ACTIVE	SO	NS	16	2000	Pb-Free (RoHS)	CU NIPDAU	Level-2-260C-1 YEAR/ Level-1-235C-UNLIM
SNJ54LS590FK	ACTIVE	LCCC	FK	20	1	TBD	Call TI	Level-NC-NC-NC
SNJ54LS590FK	ACTIVE	LCCC	FK	20	1	TBD	Call TI	Level-NC-NC-NC
SNJ54LS590J	ACTIVE	CDIP	J	16	1	TBD	Call TI	Level-NC-NC-NC
SNJ54LS590J	ACTIVE	CDIP	J	16	1	TBD	Call TI	Level-NC-NC-NC
SNJ54LS590W	ACTIVE	CFP	W	16	1	TBD	Call TI	Level-NC-NC-NC
SNJ54LS590W	ACTIVE	CFP	W	16	1	TBD	Call TI	Level-NC-NC-NC