

SN54LS31, SN74LS31 DELAY ELEMENTS

SDLS157 – DECEMBER 1983 – REVISED MARCH 1988

- Delay Elements for Generating Delay Lines
- Inverting and Non-inverting Elements
- Buffer NAND Elements Rated at I_{OL} of 12/24 mA
- PNP Inputs Reduce Fan-In ($I_{IL} = -0.2$ mA MAX)
- Worst Case MIN/MAX Delays Guaranteed Across Temperature and V_{CC} Ranges

description

These 'LS31 delay elements are intended to provide well-defined delays across both temperature and V_{CC} ranges. Used in cascade, a limitless range of delay gating is possible.

All inputs are PNP with I_{IL} MAX of -0.2 mA. Gates 1, 2, 5, and 6 have standard Low-Power Schottky output sink current capability of 4 and 8 mA I_{OL} . Buffers 3 and 4 are rated at 12 and 24 mA.

The SN54LS31 is characterized for operation over the full military temperature range of -55°C to 125°C . The SN74LS31 is characterized for operation from 0°C to 70°C .

logic symbol†

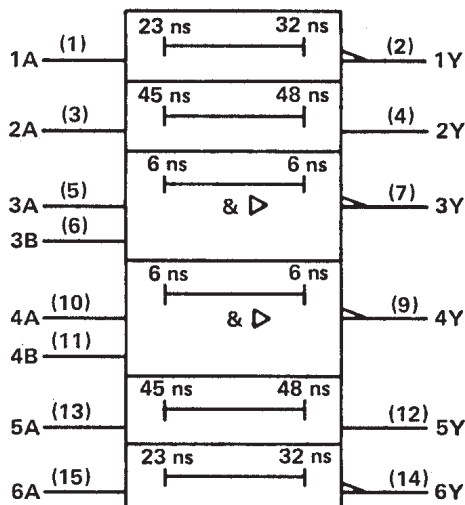

† This symbol is in accordance with ANSI/IEEE Std 91-1984 and IEC Publication 617-12.

Pin numbers shown are for D, J, N, and W packages.

SN54LS31 . . . J OR W PACKAGE
SN74LS31 . . . D OR N PACKAGE
(TOP VIEW)

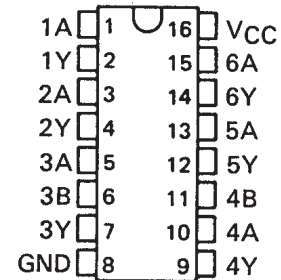

SN54LS31 . . . FK PACKAGE
(TOP VIEW)

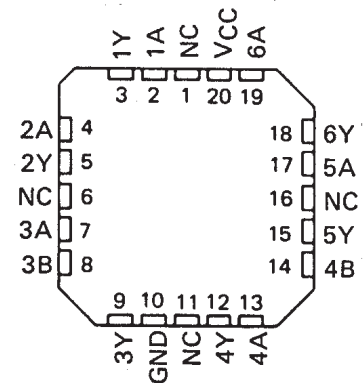

NC - No internal connection

SN54LS31, SN74LS31 DELAY ELEMENTS

SDLS157 – DECEMBER 1983 – REVISED MARCH 1988

Delay Element	Logic	Typical Delays			Rated I _{OL}
		t _{PLH}	t _{PHL}	AVG.	
Gates 1 and 6	Inverting	32 ns	23 ns	27.5 ns	4 and 8 mA
Gates 2 and 5	Non-Inverting	45 ns	48 ns	46.5 ns	4 and 8 mA
Buffers 3 and 4	2-Input NAND	6 ns	6 ns	6 ns	12 and 24 mA

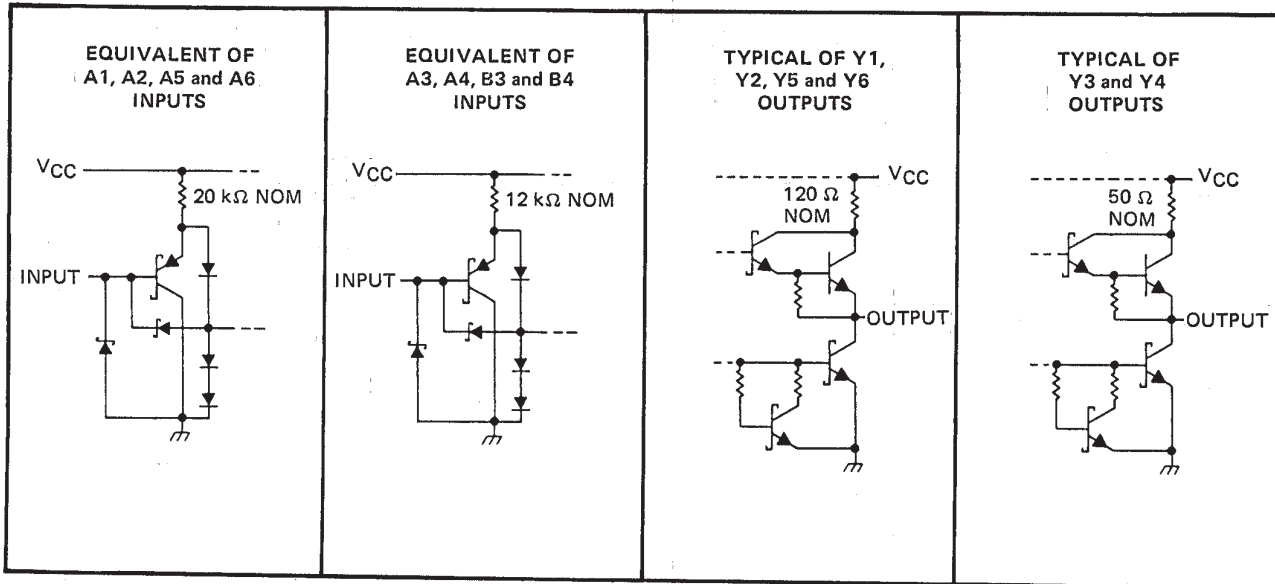

absolute maximum ratings over operating free air temperature range (unless otherwise noted)

Supply voltage, V _{CC} (See Note 1)	7 V
Input voltage, V _I : All inputs	7 V
Operating free-air temperature range: SN54LS31	– 55°C to 125°C
SN74LS31	0°C to 70°C
Storage temperature range	– 65°C to 150°C

NOTE 1: Voltage values are with respect to network ground terminal.

recommended operating conditions

	SN54LS31			SN74LS31			UNIT
	MIN	NOM	MAX	MIN	NOM	MAX	
V _{CC} Supply voltage	4.5	5	5.5	4.75	5	5.25	V
V _{IH} High-level input voltage	2			2			V
V _{IL} Low-level input voltage			0.7			0.8	V
I _{OH} High-level output current	Y3, Y4 outputs		– 1.2	Y3, Y4 outputs		– 1.2	mA
	All other outputs		– 0.4	All other outputs		– 0.4	
I _{OL} Low-level output current	Y3, Y4 outputs		12	Y3, Y4 outputs		24	mA
	All other outputs		4	All other outputs		8	
T _A Operating free-air temperature	– 55	125		0	70		°C

electrical characteristics over recommended operating free-air temperature range (unless otherwise noted)

PARAMETER	TEST CONDITIONS†		SN54LS31			SN74LS31			UNIT	
			MIN	TYP‡	MAX	MIN	TYP‡	MAX		
V _{IK}	V _{CC} = MIN, I _I = -18 mA		-1.5			-1.5			V	
V _{OH}	V _{CC} = MIN, V _{IH} = 2 V, V _{IL} = MAX	Y3, Y4	I _{OH} = -1.2 mA			2.4 3.1			V	
		Others	I _{OH} = -0.4 mA			2.5 3.1				
V _{OL}	V _{CC} = MIN, V _{IH} = 2 V, V _{IL} = MAX	Y3, Y4	I _{OL} = 12 mA			0.25 0.4			V	
			I _{OL} = 24 mA			0.35 0.5				
		Others	I _{OL} = 4 mA			0.25 0.4				
			I _{OL} = 8 mA			0.35 0.5				
I _I	V _{CC} = MAX, V _I = 7 V		0.1			0.1			mA	
I _{IH}	V _{CC} = MAX, V _I = 2.7 V		20			20			μA	
I _{IL}	V _{CC} = MAX, V _I = 0.4 V		-0.2			-0.2			mA	
I _{OS} §	V _{CC} = MAX, A3, A4, B3, B4 = 0 V		Y3, Y4			-30 -130			mA	
	V _{CC} = MAX, A1, A6 = 0 V, A2, A5 = 4.5 V		Y1, Y2, Y5, Y6			-20 -100				
I _{CC}	I _{CC} H	V _{CC} = MAX, A2, A5 = 4.5 V, all other inputs 0 V		2.3 4			2.3 4			mA
	I _{CC} L	V _{CC} = MAX, A2, A5 = 0 V, all other inputs 4.5 V		13 20			13 20			

† For conditions shown as MIN or MAX, use the appropriate value specified under recommended operating conditions.

‡ All typical values are at V_{CC} = 5 V, T_A = 25°C.

§ Not more than one output should be shorted at a time and the duration of the short-circuit should not exceed one second.

switching characteristics, (see note 2)

PARAMETER	FROM (INPUT)	TO (OUTPUT)	SN54LS31			SN74LS31			UNIT
			MIN	TYP	MAX	MIN	TYP	MAX	
t _{PLH}	A1, A6	Y1, Y6	15			22			ns
t _{PHL}			70			65			
t _{PLH}	A2, A5	Y2, Y5	9			13			ns
t _{PHL}			50			45			
t _{PLH}	A3, B3, A4, Y4	Y3, Y4	22			31			ns
t _{PHL}			90			80			
t _{PLH}	Y4	Y3, Y4	20			30			ns
t _{PHL}			105			95			
t _{PLH}	Y4	Y3, Y4	2			2			ns
t _{PHL}			20			15			
t _{PHL}	Y4	Y3, Y4	2			2			ns
t _{PHL}			20			15			

NOTE 2: V_{CC} = MIN to MAX

R_L = 667 Ω, C_L = 45 pF for Y3 and Y4.

R_L = 2 kΩ, C_L = 15 pF for Y1, Y2, Y5 and Y6.

T_A = MIN to MAX

Load circuits and voltage waveforms are shown in Section 1.

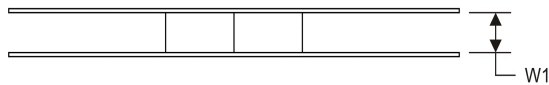
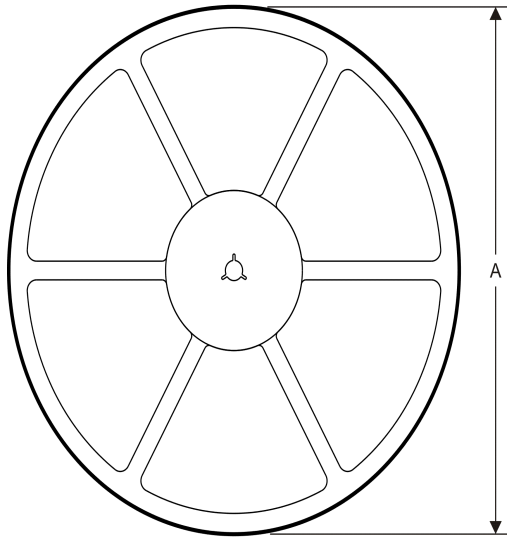
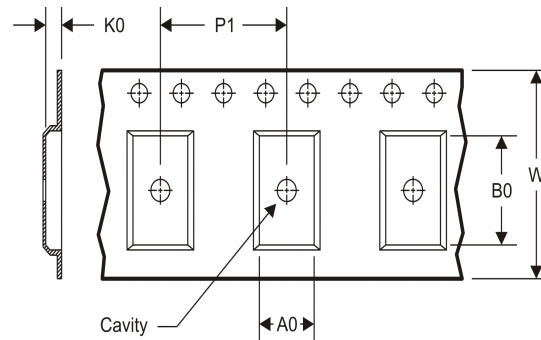
TAPE AND REEL INFORMATION
REEL DIMENSIONS

TAPE DIMENSIONS

A0	Dimension designed to accommodate the component width
B0	Dimension designed to accommodate the component length
K0	Dimension designed to accommodate the component thickness
W	Overall width of the carrier tape
P1	Pitch between successive cavity centers

TAPE AND REEL INFORMATION

*All dimensions are nominal

Device	Package Type	Package Drawing	Pins	SPQ	Reel Diameter (mm)	Reel Width W1 (mm)	A0 (mm)	B0 (mm)	K0 (mm)	P1 (mm)	W (mm)	Pin1 Quadrant
SN74LS31NSR	SO	NS	16	2000	330.0	16.4	8.2	10.5	2.5	12.0	16.0	Q1

TAPE AND REEL BOX DIMENSIONS

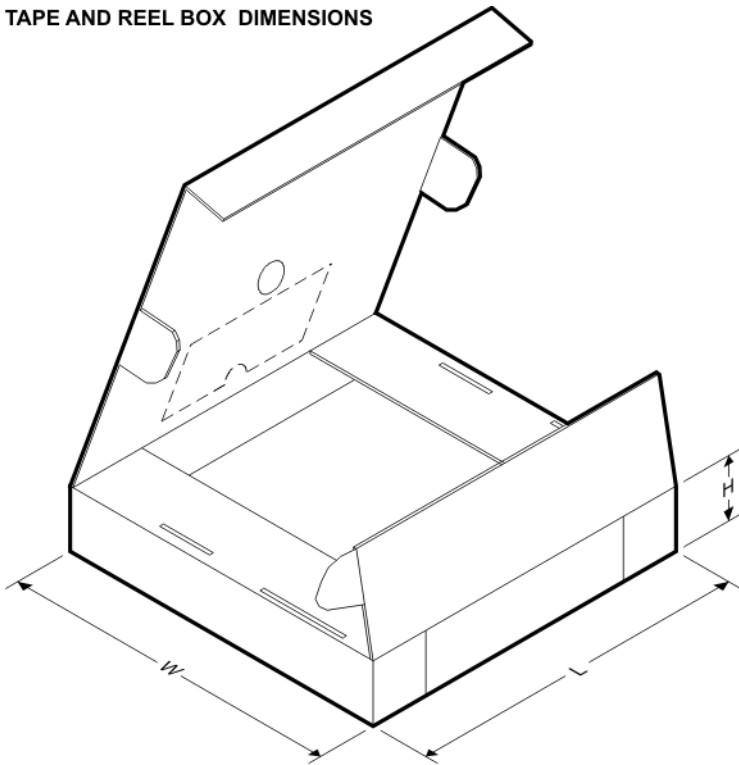

*All dimensions are nominal

Device	Package Type	Package Drawing	Pins	SPQ	Length (mm)	Width (mm)	Height (mm)
SN74LS31NSR	SO	NS	16	2000	367.0	367.0	38.0

IMPORTANT NOTICE

Texas Instruments Incorporated and its subsidiaries (TI) reserve the right to make corrections, enhancements, improvements and other changes to its semiconductor products and services per JESD46C and to discontinue any product or service per JESD48B. Buyers should obtain the latest relevant information before placing orders and should verify that such information is current and complete. All semiconductor products (also referred to herein as "components") are sold subject to TI's terms and conditions of sale supplied at the time of order acknowledgment.

TI warrants performance of its components to the specifications applicable at the time of sale, in accordance with the warranty in TI's terms and conditions of sale of semiconductor products. Testing and other quality control techniques are used to the extent TI deems necessary to support this warranty. Except where mandated by applicable law, testing of all parameters of each component is not necessarily performed.

TI assumes no liability for applications assistance or the design of Buyers' products. Buyers are responsible for their products and applications using TI components. To minimize the risks associated with Buyers' products and applications, Buyers should provide adequate design and operating safeguards.

TI does not warrant or represent that any license, either express or implied, is granted under any patent right, copyright, mask work right, or other intellectual property right relating to any combination, machine, or process in which TI components or services are used. Information published by TI regarding third-party products or services does not constitute a license to use such products or services or a warranty or endorsement thereof. Use of such information may require a license from a third party under the patents or other intellectual property of the third party, or a license from TI under the patents or other intellectual property of TI.

Reproduction of significant portions of TI information in TI data books or data sheets is permissible only if reproduction is without alteration and is accompanied by all associated warranties, conditions, limitations, and notices. TI is not responsible or liable for such altered documentation. Information of third parties may be subject to additional restrictions.

Resale of TI components or services with statements different from or beyond the parameters stated by TI for that component or service voids all express and any implied warranties for the associated TI component or service and is an unfair and deceptive business practice. TI is not responsible or liable for any such statements.

Buyer acknowledges and agrees that it is solely responsible for compliance with all legal, regulatory and safety-related requirements concerning its products, and any use of TI components in its applications, notwithstanding any applications-related information or support that may be provided by TI. Buyer represents and agrees that it has all the necessary expertise to create and implement safeguards which anticipate dangerous consequences of failures, monitor failures and their consequences, lessen the likelihood of failures that might cause harm and take appropriate remedial actions. Buyer will fully indemnify TI and its representatives against any damages arising out of the use of any TI components in safety-critical applications.

In some cases, TI components may be promoted specifically to facilitate safety-related applications. With such components, TI's goal is to help enable customers to design and create their own end-product solutions that meet applicable functional safety standards and requirements. Nonetheless, such components are subject to these terms.

No TI components are authorized for use in FDA Class III (or similar life-critical medical equipment) unless authorized officers of the parties have executed a special agreement specifically governing such use.

Only those TI components which TI has specifically designated as military grade or "enhanced plastic" are designed and intended for use in military/aerospace applications or environments. Buyer acknowledges and agrees that any military or aerospace use of TI components which have **not** been so designated is solely at the Buyer's risk, and that Buyer is solely responsible for compliance with all legal and regulatory requirements in connection with such use.

TI has specifically designated certain components which meet ISO/TS16949 requirements, mainly for automotive use. Components which have not been so designated are neither designed nor intended for automotive use; and TI will not be responsible for any failure of such components to meet such requirements.

Products

Audio	www.ti.com/audio
Amplifiers	amplifier.ti.com
Data Converters	dataconverter.ti.com
DLP® Products	www.dlp.com
DSP	dsp.ti.com
Clocks and Timers	www.ti.com/clocks
Interface	interface.ti.com
Logic	logic.ti.com
Power Mgmt	power.ti.com
Microcontrollers	microcontroller.ti.com
RFID	www.ti-rfid.com
OMAP Mobile Processors	www.ti.com/omap
Wireless Connectivity	www.ti.com/wirelessconnectivity

Applications

Automotive and Transportation	www.ti.com/automotive
Communications and Telecom	www.ti.com/communications
Computers and Peripherals	www.ti.com/computers
Consumer Electronics	www.ti.com/consumer-apps
Energy and Lighting	www.ti.com/energy
Industrial	www.ti.com/industrial
Medical	www.ti.com/medical
Security	www.ti.com/security
Space, Avionics and Defense	www.ti.com/space-avionics-defense
Video and Imaging	www.ti.com/video

TI E2E Community e2e.ti.com