

SN54LS297, SN74LS297 DIGITAL PHASE-LOCKED-LOOP FILTERS

SDLS155 – JANUARY 1981 – REVISED MARCH 1988

- Digital Design Avoids Analog Compensation Errors
- Easily Cascadable for Higher Order Loops
- Useful Frequency from DC to:
50 MHz Typical (K Clock)
35 MHz Typical (I/D Clock)

description

The SN54LS297 and SN74LS297 devices are designed to provide a simple, cost-effective solution to high-accuracy, digital, phase-locked-loop applications. These devices contain all the necessary circuits, with the exception of the divide-by-N counter, to build first order phase-locked loops as described in Figure 1.

Both exclusive-OR (XORPD) and edge-controlled (ECPD) phase detectors are provided for maximum flexibility.

Proper partitioning of the loop function, with many of the building blocks external to the package, makes it easy for the designer to incorporate ripple cancellation or to cascade to higher order phase-locked loops.

The length of the up/down K counter is digitally programmable according to the K counter function table. With A, B, C, and D all low, the K counter is disabled. With A high and B, C, and D low, the K counter is only three stages long, which widens the bandwidth or capture range and shortens the lock time of the loop. When A, B, C, and D are all programmed high, the K counter becomes seventeen stages long, which narrows the bandwidth or capture range and lengthens the lock time. Real-time control of loop bandwidth by manipulating the A through D inputs can maximize the overall performance of the digital phase-locked loop.

SN54LS297 . . . J OR W PACKAGE
SN74LS297 . . . N PACKAGE

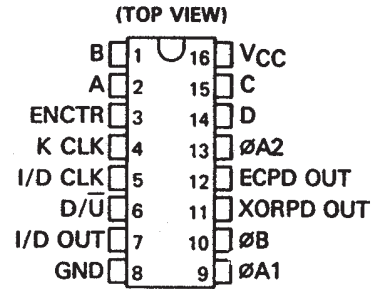

SN54LS297 . . . FK PACKAGE
(TOP VIEW)

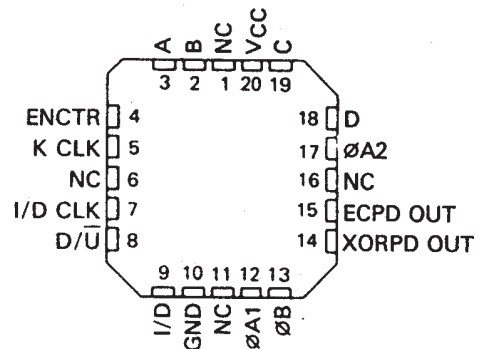

NC—No internal connection

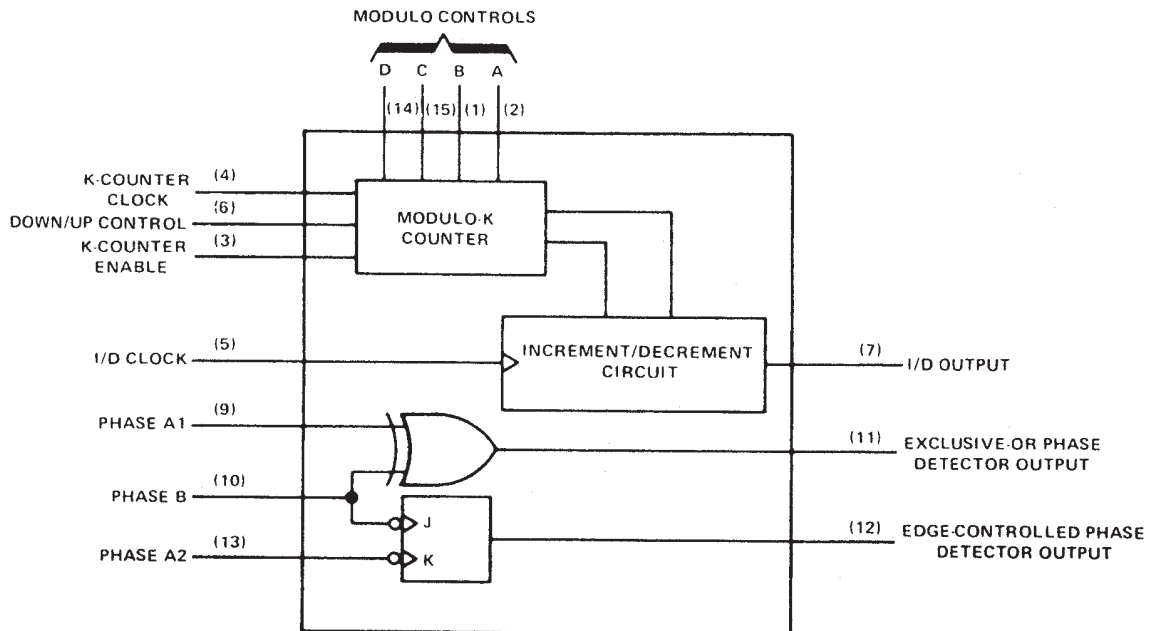

FIGURE 1—SIMPLIFIED BLOCK DIAGRAM

Pin numbers shown are for J, N and W packages.

PRODUCTION DATA information is current as of publication date. Products conform to specifications per the terms of Texas Instruments standard warranty. Production processing does not necessarily include testing of all parameters.

TEXAS
INSTRUMENTS

POST OFFICE BOX 655303 • DALLAS, TEXAS 75265

Copyright © 1988, Texas Instruments Incorporated

SN54LS297, SN74LS297 DIGITAL PHASE-LOCKED-LOOP FILTERS

SDLS155 – JANUARY 1981 – REVISED MARCH 1988

description (continued)

The 'LS297 can perform the classic first-order phase-locked loop function without using analog components. The accuracy of the digital phase-locked loop (DPLL) is not affected by V_{CC} and temperature variations, but depends solely on accuracies of the K clock, I/D clock, and loop propagation delays. The I/D clock frequency and the divide-by-N modulus will determine the center frequency of the DPLL. The center frequency is defined by the relationship $f_c = I/D \text{ Clock}/2N$ (Hz).

logic diagram (positive logic)

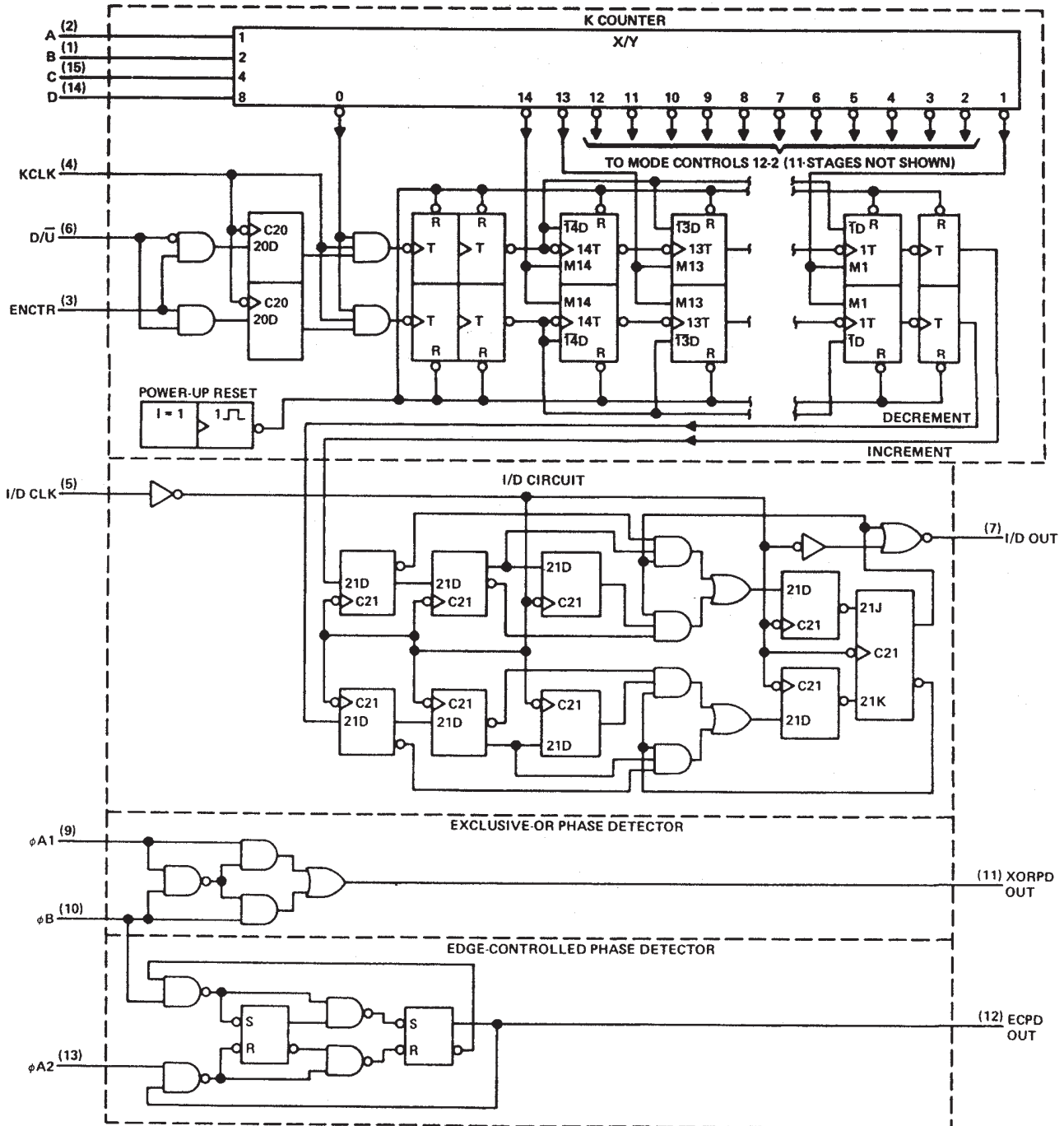

Pin numbers shown are for J, N, and W packages.



POST OFFICE BOX 655303 • DALLAS, TEXAS 75265

SN54LS297, SN74LS297 DIGITAL PHASE-LOCKED-LOOP FILTERS

SDLS155 – JANUARY 1981 – REVISED MARCH 1988

**K COUNTER FUNCTION TABLE
(DIGITAL CONTROL)**

D	C	B	A	MODULO (K)
L	L	L	L	Inhibited
L	L	L	H	23
L	L	H	L	24
L	L	H	H	25
L	H	L	L	26
L	H	L	H	27
L	H	H	L	28
L	H	H	H	29
H	L	L	L	210
H	L	L	H	211
H	L	H	L	212
H	L	H	H	213
H	H	L	L	214
H	H	L	H	215
H	H	H	L	216
H	H	H	H	217

**FUNCTION TABLE
EXCLUSIVE-OR PHASE DETECTOR**

$\phi A1$	ϕB	XORPD OUT
L	L	L
L	H	H
H	L	H
H	H	L

**FUNCTION TABLE
EDGE-CONTROLLED PHASE DETECTOR**

$\phi A2$	ϕB	ECPD OUT
H or L	↓	H
↓	H or L	L
H or L	↑	No change
↑	H or L	No change

H = steady-state high level
L = steady-state low level
↓ = transition from high to low
↑ = transition from low to high

schematics of inputs and outputs

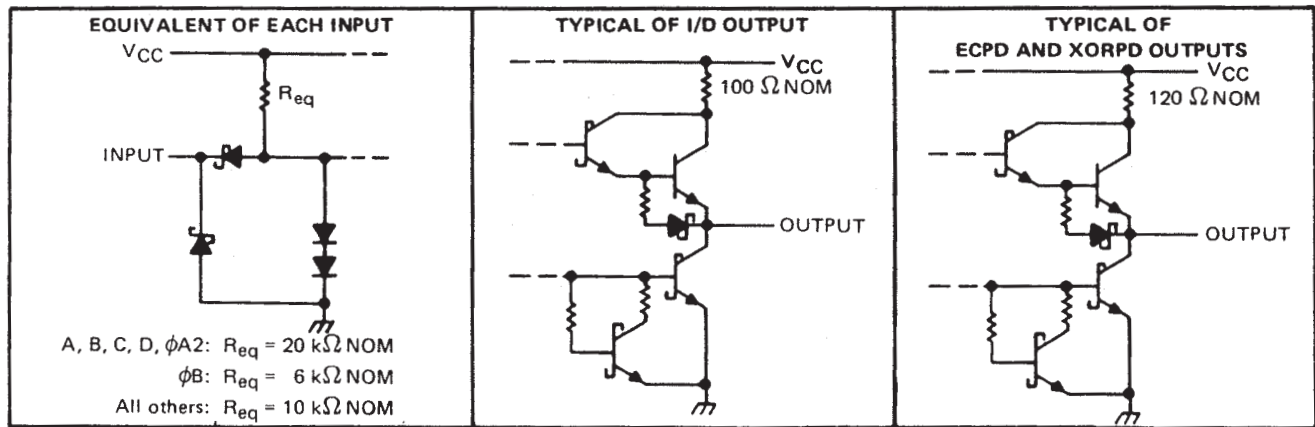

operation

The phase detector generates an error signal waveform that, at zero phase error, is a 50% duty cycle square wave. At the limits of linear operation, the phase detector output will be either high or low all of the time, depending on the direction of the phase error ($\phi_{in} - \phi_{out}$). Within these limits, the phase detector output varies linearly with the input phase error according to the gain k_D , which is expressed in terms of phase detector output per cycle of phase error. The phase detector output can be defined to vary between ± 1 according to the relation:

$$\text{PD Output} = \frac{\% \text{ high} - \% \text{ low}}{100} \quad (1)$$

The output of the phase detector will be $k_D \phi_e$, where the phase error $\phi_e = \phi_{in} - \phi_{out}$.

SN54LS297, SN74LS297 DIGITAL PHASE-LOCKED-LOOP FILTERS

SDLS155 – JANUARY 1981 – REVISED MARCH 1988

Exclusive-OR phase detectors (XORPD) and edge-controlled phase detectors (ECPD) are commonly used digital types. The ECPD is more complex than the XORPD logic function, but can be described generally as a circuit that changes states on one of the transitions of its inputs. k_d for an XORPD is 4 because its output remains high (PD output = 1) for a phase error of 1/4 cycle. Similarly, k_d for the ECPD is 2 since its output remains high for a phase error of 1/2 cycle. The type of phase detector will determine the zero-phase-error point, i.e., the phase separation of the phase detector inputs for ϕ_e defined to be zero. For the basic DPLL system of Figure 2, $\phi_e = 0$ when the phase detector output is a square wave. The XORPD inputs are 1/4 cycle out of phase for zero phase error. For the ECPD, $\phi_e = 0$ when the inputs are 1/2 cycle out of phase.

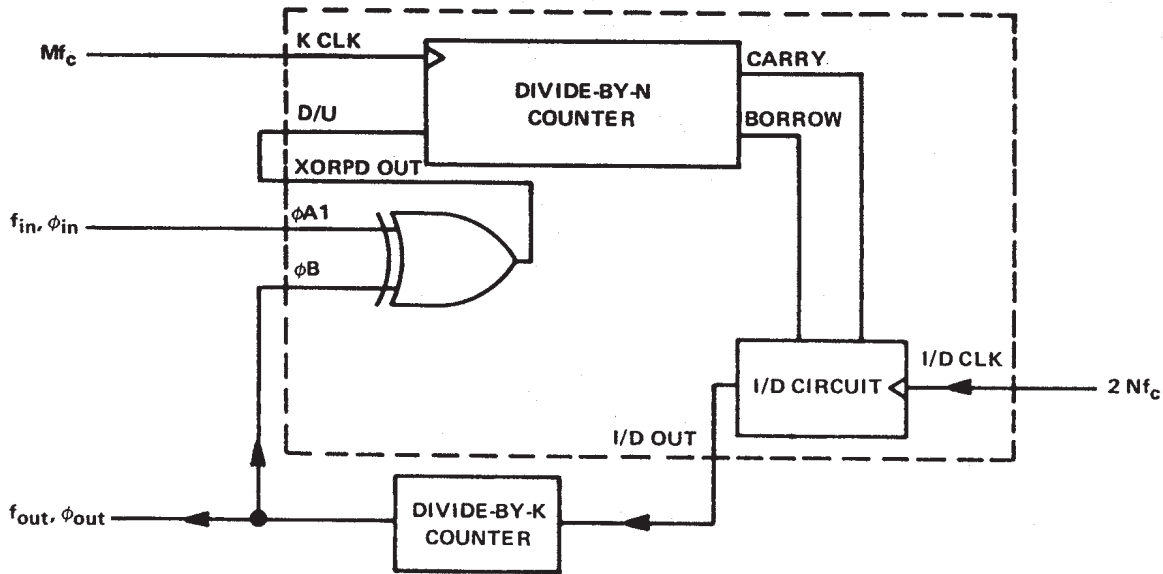

FIGURE 2—DPLL USING EXCLUSIVE-OR PHASE DETECTION

The phase detector output controls the up/down input to the K counter. The counter is clocked by input frequency Mf_c , which is a multiple M of the loop center frequency f_c . When the K counter recycles up, it generates a carry pulse. Recycling while counting down generates a borrow pulse. If the carry and borrow outputs are conceptually combined into one output that is positive for a carry and negative for a borrow, and if the K counter is considered as a frequency divider with the ratio Mf_c/K , the output of the K counter will equal the input frequency multiplied by the division ratio. Thus the output from the K counter is $(k_d \phi_e Mf_c)/K$.

The carry and borrow pulses go to the increment/decrement (I/D) circuit, which, in the absence of any carry or borrow pulse, has an output that is 1/2 of the input clock I/D CLK. The input clock is just a multiple, $2N$, of the loop center frequency. In response to a carry or borrow pulse, the I/D circuit will either add or delete a pulse at I/D OUT. Thus the output of the I/D circuit will be $Nf_c + (k_d \phi_e Mf_c)/2K$.

The output of the N counter (or the output of the phase-locked loop) is thus:

$$f_o = f_c + (k_d \phi_e Mf_c)/2KN$$

If this result is compared to the equation for a first-order analog phase-locked loop, the digital equivalent of the gain of the VCO is just $Mf_c/2KN$ or f_c/K for $M = 2N$.

Thus the simple first-order phase-locked loop with an adjustable K counter is the equivalent of an analog phase-locked loop with a programmable VCO gain.

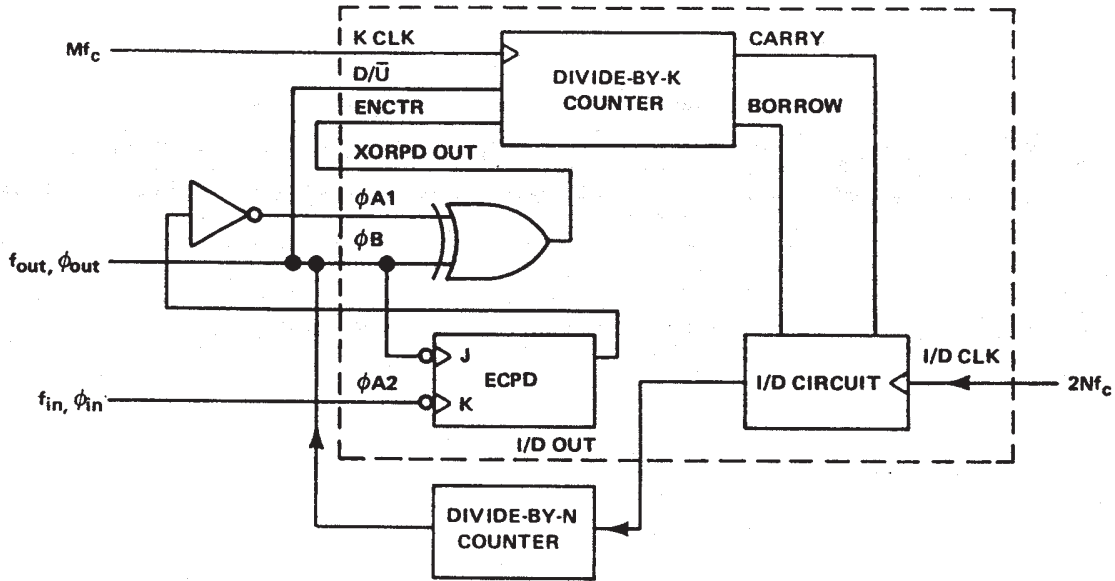

FIGURE 3—DPLL USING BOTH PHASE DETECTORS IN A RIPPLE-CANCELLATION SCHEME

absolute maximum rating over operating free-air temperature range (unless otherwise noted)

Supply voltage, V_{CC} (see Note 1)	7 V
Input voltage	7 V
Operating free-air temperature range: SN54LS297	-55°C to 125°C
SN74LS297	0°C to 70°C
Storage temperature range	-65°C to 150°C

NOTE 1: Voltage values are with respect to network ground terminal.

recommended operating conditions

		SN54LS297			SN74LS297			UNIT
		MIN	NOM	MAX	MIN	NOM	MAX	
V_{CC}	Supply voltage	4.5	5	5.5	4.75	5	5.25	V
I_{OH}	High-level output current	I/D OUT		-1.2	-1.2		mA	
		EXOR, ECPD		-400	-400		μ A	
I_{OL}	Low-level output current	I/D OUT		12	24		mA	
		XOR, ECPD		4	8		mA	
f_{clock}	Clock frequency	K Clock		0	32	0	32	MHz
		I/D Clock		0	16	0	16	MHz
t_w	Width of clock input pulse	K Clock		16	16		ns	
		I/D Clock		33	33		ns	
$t_{su, to K}$	Setup time to K Clock \dagger	U/ \bar{D} , ENCTR		30	30		ns	
t_h	Hold time from K Clock \dagger	U/ \bar{D} , ENCTR		0	0		ns	
T_A	Operating free-air temperature	-55	125	0	70	°C		

SN54LS297, SN74LS297 DIGITAL PHASE-LOCKED-LOOP FILTERS

SDLS155 – JANUARY 1981 – REVISED MARCH 1988

electrical characteristics over recommended operating free-air temperature range (unless otherwise noted)

PARAMETER		TEST CONDITIONS†	SN54LS297			SN74LS297			UNIT
			MIN	TYP‡	MAX	MIN	TYP‡	MAX	
V _{IH}	High-level input voltage		2			2			V
V _{IL}	Low-level input voltage			0.7			0.8		V
V _{IK}	Input clamp voltage	V _{CC} = MIN, I _I = -18 mA			-1.5			-1.5	V
V _{OH}	High-level output voltage	I/D OUT	V _{CC} = MIN, V _{IH} = 2 V, V _{IL} = V _{IL max}	I _{OH} = MAX	2.4		2.4		V
		Others		I _{OH} = MAX	2.5		2.7		
V _{OL}	Low-level output voltage	I/D OUT	V _{CC} = MIN, V _{IH} = 2 V, V _{IL} = V _{IL max}	I _{OL} = 12 mA	0.25	0.4	0.25	0.4	V
				I _{OL} = 24 mA			0.35	0.5	
		Others		I _{OL} = 4 mA	0.25	0.4	0.25	0.4	
				I _{OL} = 8 mA			0.35	0.5	
I _I	Input current at maximum input voltage	V _{CC} = MAX, V _I = 7 V			0.1		0.1	mA	
I _{IH}	High-level input current	U/D, EN, φA1	V _{CC} = MAX, V _I = 2.7 V			40		40	μA
		φB				60		60	
		All others				20		20	
I _{IL}	Low-level input current	U/D, EN, φA1	V _{CC} = MAX, V _I = 0.4 V			-0.8		-0.8	mA
		φB				-1.2		-1.2	
		All others				-0.4		-0.4	
I _{OS}	Short-circuit output current §	I/D OUT	V _{CC} = MAX		-30	-130	-30	-130	mA
		Others			-20	-100	-20	-100	
I _{CC}	Supply current	V _{CC} = MAX, All inputs grounded, All outputs open		75	120		75	120	mA

† For conditions shown as MIN or MAX, use the appropriate value specified under recommended operating conditions.

‡ All typical values are of V_{CC} = 5 V, T_A = 25°C.

§ Not more than one output should be shorted at a time and the duration of the short-circuit should not exceed one second.

switching characteristics, V_{CC} = 5 V, T_A = 25°C

PARAMETER¶	FROM (INPUT)		TO (OUTPUT)	TEST CONDITIONS	MIN	TYP	MAX	UNIT
f _{max}	KCLK		I/D OUT	R _L = 667 Ω, C _L = 45 pF, See Note 2	32	50		MHz
	I/D CLK		I/D OUT		16	35		
t _{PLH}	I/D CLK ↑		I/D OUT	See Note 2		15	25	ns
t _{PHL}	I/D CLK ↑		I/D OUT			22	35	ns
t _{PLH}	φA1 or φB	Other input low	XOR OUT	R _L = 2 k Ω, C _L = 45 pF, See Note 2		10	15	ns
	φA1 or φB	Other input high	XOR OUT			17	25	
t _{PHL}	φA1 or φB	Other input low	XOR OUT			15	25	ns
	φA1 or φB	Other input high	XOR OUT			17	25	
t _{PLH}	φB ↓		ECPD OUT			20	30	ns
t _{PHL}	φA2 ↓		ECPD OUT			20	30	ns

¶ t_{PLH} = propagation delay time, low-to-high-level output

t_{PHL} = propagation delay time, high-to-low-level output

NOTE 2: Load circuits and voltage waveforms are shown in Section 1.



POST OFFICE BOX 655303 • DALLAS, TEXAS 75265

PACKAGING INFORMATION

Orderable Device	Status ⁽¹⁾	Package Type	Package Drawing	Pins	Package Qty	Eco Plan ⁽²⁾	Lead/Ball Finish	MSL Peak Temp ⁽³⁾
SN74LS297N	ACTIVE	PDIP	N	16	25	Pb-Free (RoHS)	CU NIPDAU	N / A for Pkg Type
SN74LS297NE4	ACTIVE	PDIP	N	16	25	Pb-Free (RoHS)	CU NIPDAU	N / A for Pkg Type
SN74LS297NE4	ACTIVE	PDIP	N	16	25	Pb-Free (RoHS)	CU NIPDAU	N / A for Pkg Type

⁽¹⁾ The marketing status values are defined as follows:

ACTIVE: Product device recommended for new designs.

LIFEBUY: TI has announced that the device will be discontinued, and a lifetime-buy period is in effect.

NRND: Not recommended for new designs. Device is in production to support existing customers, but TI does not recommend using this part in a new design.

PREVIEW: Device has been announced but is not in production. Samples may or may not be available.

OBsolete: TI has discontinued the production of the device.

⁽²⁾ Eco Plan - The planned eco-friendly classification: Pb-Free (RoHS), Pb-Free (RoHS Exempt), or Green (RoHS & no Sb/Br) - please check <http://www.ti.com/productcontent> for the latest availability information and additional product content details.

TBD: The Pb-Free/Green conversion plan has not been defined.

Pb-Free (RoHS): TI's terms "Lead-Free" or "Pb-Free" mean semiconductor products that are compatible with the current RoHS requirements for all 6 substances, including the requirement that lead not exceed 0.1% by weight in homogeneous materials. Where designed to be soldered at high temperatures, TI Pb-Free products are suitable for use in specified lead-free processes.

Pb-Free (RoHS Exempt): This component has a RoHS exemption for either 1) lead-based flip-chip solder bumps used between the die and package, or 2) lead-based die adhesive used between the die and leadframe. The component is otherwise considered Pb-Free (RoHS compatible) as defined above.

Green (RoHS & no Sb/Br): TI defines "Green" to mean Pb-Free (RoHS compatible), and free of Bromine (Br) and Antimony (Sb) based flame retardants (Br or Sb do not exceed 0.1% by weight in homogeneous material)

⁽³⁾ MSL, Peak Temp. -- The Moisture Sensitivity Level rating according to the JEDEC industry standard classifications, and peak solder temperature.

Important Information and Disclaimer:The information provided on this page represents TI's knowledge and belief as of the date that it is provided. TI bases its knowledge and belief on information provided by third parties, and makes no representation or warranty as to the accuracy of such information. Efforts are underway to better integrate information from third parties. TI has taken and continues to take reasonable steps to provide representative and accurate information but may not have conducted destructive testing or chemical analysis on incoming materials and chemicals. TI and TI suppliers consider certain information to be proprietary, and thus CAS numbers and other limited information may not be available for release.

In no event shall TI's liability arising out of such information exceed the total purchase price of the TI part(s) at issue in this document sold by TI to Customer on an annual basis.

N (R-PDIP-T**)

PLASTIC DUAL-IN-LINE PACKAGE

16 PINS SHOWN



- NOTES:
- A. All linear dimensions are in inches (millimeters).
 - B. This drawing is subject to change without notice.
 - Falls within JEDEC MS-001, except 18 and 20 pin minimum body length (Dim A).
 - The 20 pin end lead shoulder width is a vendor option, either half or full width.

IMPORTANT NOTICE

Texas Instruments Incorporated and its subsidiaries (TI) reserve the right to make corrections, modifications, enhancements, improvements, and other changes to its products and services at any time and to discontinue any product or service without notice. Customers should obtain the latest relevant information before placing orders and should verify that such information is current and complete. All products are sold subject to TI's terms and conditions of sale supplied at the time of order acknowledgment.

TI warrants performance of its hardware products to the specifications applicable at the time of sale in accordance with TI's standard warranty. Testing and other quality control techniques are used to the extent TI deems necessary to support this warranty. Except where mandated by government requirements, testing of all parameters of each product is not necessarily performed.

TI assumes no liability for applications assistance or customer product design. Customers are responsible for their products and applications using TI components. To minimize the risks associated with customer products and applications, customers should provide adequate design and operating safeguards.

TI does not warrant or represent that any license, either express or implied, is granted under any TI patent right, copyright, mask work right, or other TI intellectual property right relating to any combination, machine, or process in which TI products or services are used. Information published by TI regarding third-party products or services does not constitute a license from TI to use such products or services or a warranty or endorsement thereof. Use of such information may require a license from a third party under the patents or other intellectual property of the third party, or a license from TI under the patents or other intellectual property of TI.

Reproduction of information in TI data books or data sheets is permissible only if reproduction is without alteration and is accompanied by all associated warranties, conditions, limitations, and notices. Reproduction of this information with alteration is an unfair and deceptive business practice. TI is not responsible or liable for such altered documentation.

Resale of TI products or services with statements different from or beyond the parameters stated by TI for that product or service voids all express and any implied warranties for the associated TI product or service and is an unfair and deceptive business practice. TI is not responsible or liable for any such statements.

Following are URLs where you can obtain information on other Texas Instruments products and application solutions:

Products		Applications	
Amplifiers	amplifier.ti.com	Audio	www.ti.com/audio
Data Converters	dataconverter.ti.com	Automotive	www.ti.com/automotive
DSP	dsp.ti.com	Broadband	www.ti.com/broadband
Interface	interface.ti.com	Digital Control	www.ti.com/digitalcontrol
Logic	logic.ti.com	Military	www.ti.com/military
Power Mgmt	power.ti.com	Optical Networking	www.ti.com/opticalnetwork
Microcontrollers	microcontroller.ti.com	Security	www.ti.com/security
Low Power Wireless	www.ti.com/lpw	Telephony	www.ti.com/telephony
		Video & Imaging	www.ti.com/video
		Wireless	www.ti.com/wireless

Mailing Address: Texas Instruments
Post Office Box 655303 Dallas, Texas 75265