

Distributed by:

JAMECO[®]
ELECTRONICS

www.Jameco.com ♦ 1-800-831-4242

The content and copyrights of the attached
material are the property of its owner.

Jameco Part Number 1017074

SN54190, SN54191, SN54LS190, SN54LS191, SN74190, SN74191, SN74LS190, SN74LS191 SYNCHRONOUS UP/DOWN COUNTERS WITH DOWN/UP MODE CONTROL

SDLS072 - DECEMBER 1972 - REVISED MARCH 1988

- Counts 8-4-2-1 BCD or Binary
- Single Down/Up Count Control Line
- Count Enable Control Input
- Ripple Clock Output for Cascading
- Asynchronously Presetable with Load Control
- Parallel Outputs
- Cascadable for n-Bit Applications

SN54190, SN54191, SN54LS190,
SN54LS191 . . . J PACKAGE
SN74190, SN74191 . . . N PACKAGE
SN74LS190, SN74LS191 . . . D OR N PACKAGE

(TOP VIEW)

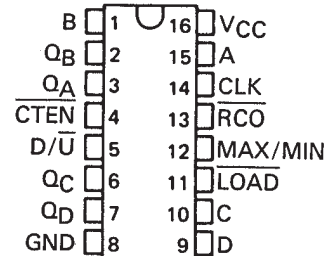

TYPE	AVERAGE PROPAGATION DELAY	TYPICAL MAXIMUM CLOCK FREQUENCY	TYPICAL POWER DISSIPATION
'190,'191	20ns	25MHz	325mW
'LS190,'LS191	20ns	25MHz	100mW

SN54LS190, SN54LS191 . . . FK PACKAGE

(TOP VIEW)

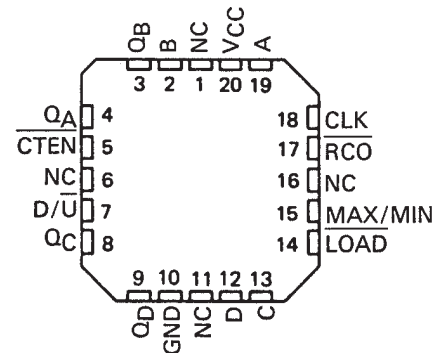

NC - No internal connection

description

The '190, 'LS190, '191, and 'LS191 are synchronous, reversible up/down counters having a complexity of 58 equivalent gates. The '191 and 'LS191 are 4-bit binary counters and the '190 and 'LS190 are BCD counters. Synchronous operation is provided by having all flip-flops clocked simultaneously so that the outputs change coincident with each other when so instructed by the steering logic. This mode of operation eliminates the output counting spikes normally associated with asynchronous (ripple clock) counters.

The outputs of the four master-slave flip-flops are triggered on a low-to-high transition of the clock input if the enable input is low. A high at the enable input inhibits counting. Level changes at the enable input should be made only when the clock input is high. The direction of the count is determined by the level of the down/up input. When low, the counter count up and when high, it counts down. A false clock may occur if the down/up input changes while the clock is low. A false ripple carry may occur if both the clock and enable are low and the down/up input is high during a load pulse.

These counters are fully programmable; that is, the outputs may be preset to either level by placing a low on the load input and entering the desired data at the data inputs. The output will change to agree with the data inputs independently of the level of the clock input. This feature allows the counters to be used as modulo-N dividers by simply modifying the count length with the preset inputs.

The clock, down/up, and load inputs are buffered to lower the drive requirement which significantly reduces the number of clock drivers, etc., required for long parallel words.

Two outputs have been made available to perform the cascading function: ripple clock and maximum/minimum count. The latter output produces a high-level output pulse with a duration approximately equal to one complete cycle of the clock when the counter overflows or underflows. The ripple clock output produces a low-level output pulse equal in width to the low-level portion of the clock input when an overflow or underflow condition exists. The counters can be easily cascaded by feeding the ripple clock output to the enable input of the succeeding counter if parallel clocking is used, or to the clock input if parallel enabling is used. The maximum/minimum count output can be used to accomplish look-ahead for high-speed operation.

Series 54' and 54LS' are characterized for operation over the full military temperature range of -55°C to 125°C ; Series 74' and 74LS' are characterized for operation from 0°C to 70°C .

PRODUCTION DATA information is current as of publication date. Products conform to specifications per the terms of Texas Instruments standard warranty. Production processing does not necessarily include testing of all parameters.

 **TEXAS
INSTRUMENTS**

POST OFFICE BOX 655303 • DALLAS, TEXAS 75265

Copyright © 1988, Texas Instruments Incorporated

SN54190, SN54191, SN54LS190, SN54LS191,
 SN74190, SN74191, SN74LS190, SN74LS191
 SYNCHRONOUS UP/DOWN COUNTERS WITH DOWN/UP MODE CONTROL

SDLS072 – DECEMBER 1972 – REVISED MARCH 1988

logic symbols†

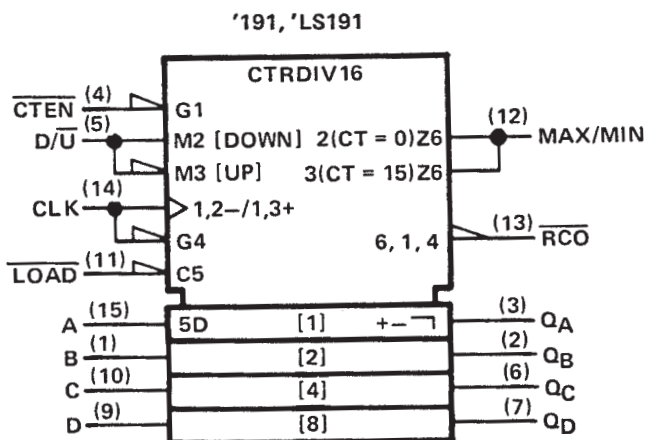
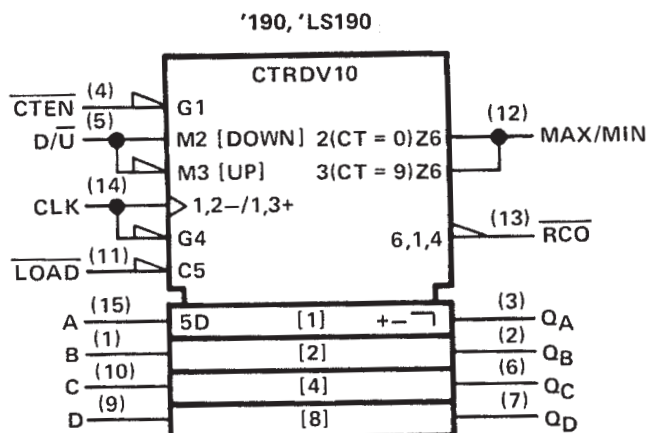

† These symbols are accordance with ANSI/IEEE Std 91-1984 and IEC Publication 617-12.
 Pin numbers shown are for D, J, and N packages.

SN54190, SN54LS190, SN74190, SN74LS190

SYNCHRONOUS UP/DOWN COUNTERS WITH DOWN/UP MODE CONTROL

SDLS072 – DECEMBER 1972 – REVISED MARCH 1988

logic diagram (positive logic)

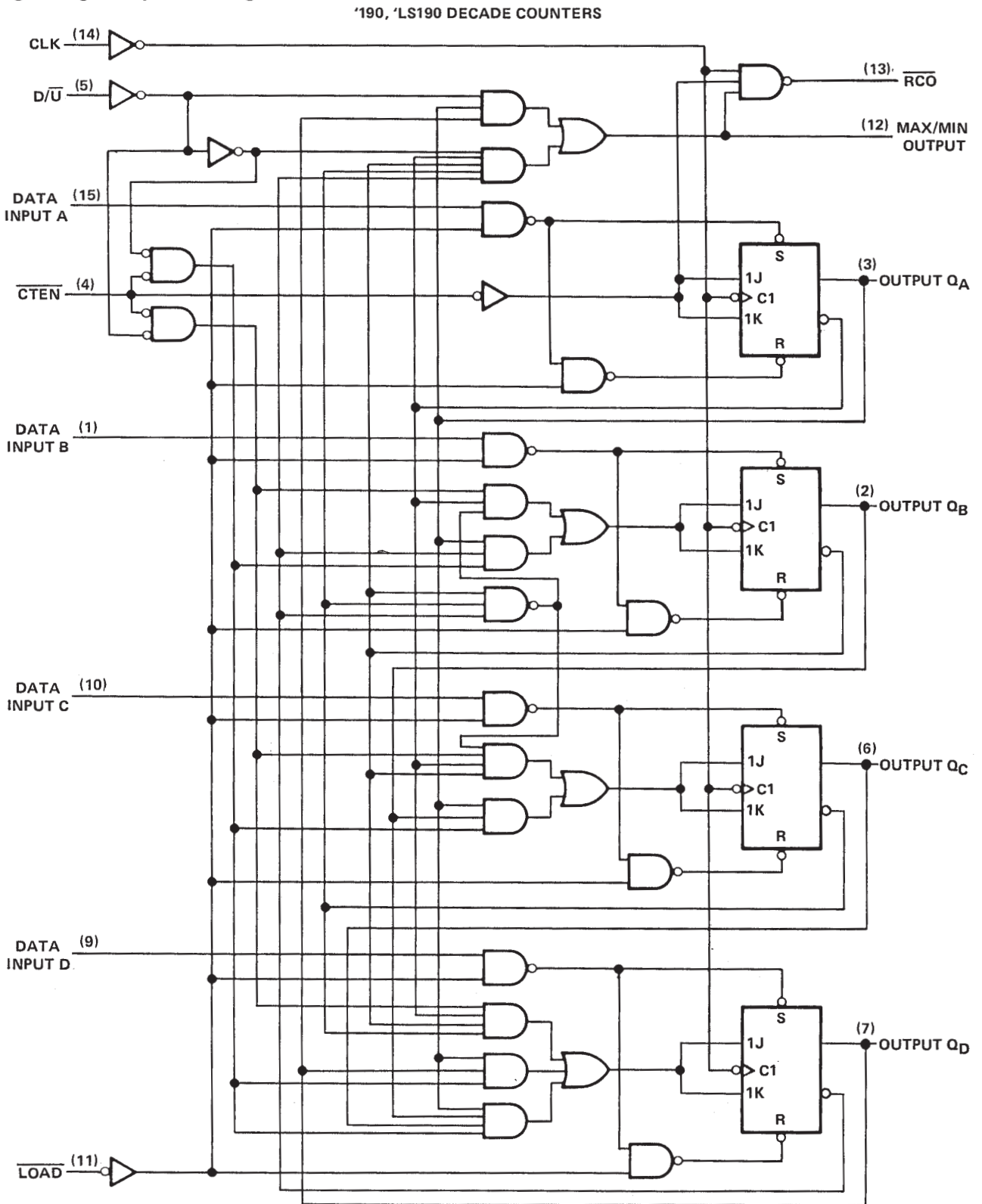

Pin numbers shown are for D, J, and N packages.



POST OFFICE BOX 655303 • DALLAS, TEXAS 75265

SN54191, SN54LS191, SN74191, SN74LS191

SYNCHRONOUS UP/DOWN COUNTERS WITH DOWN/UP MODE CONTROL

SDLS072 – DECEMBER 1972 – REVISED MARCH 1988

logic diagram (positive logic)

'191, 'LS191 BINARY COUNTERS

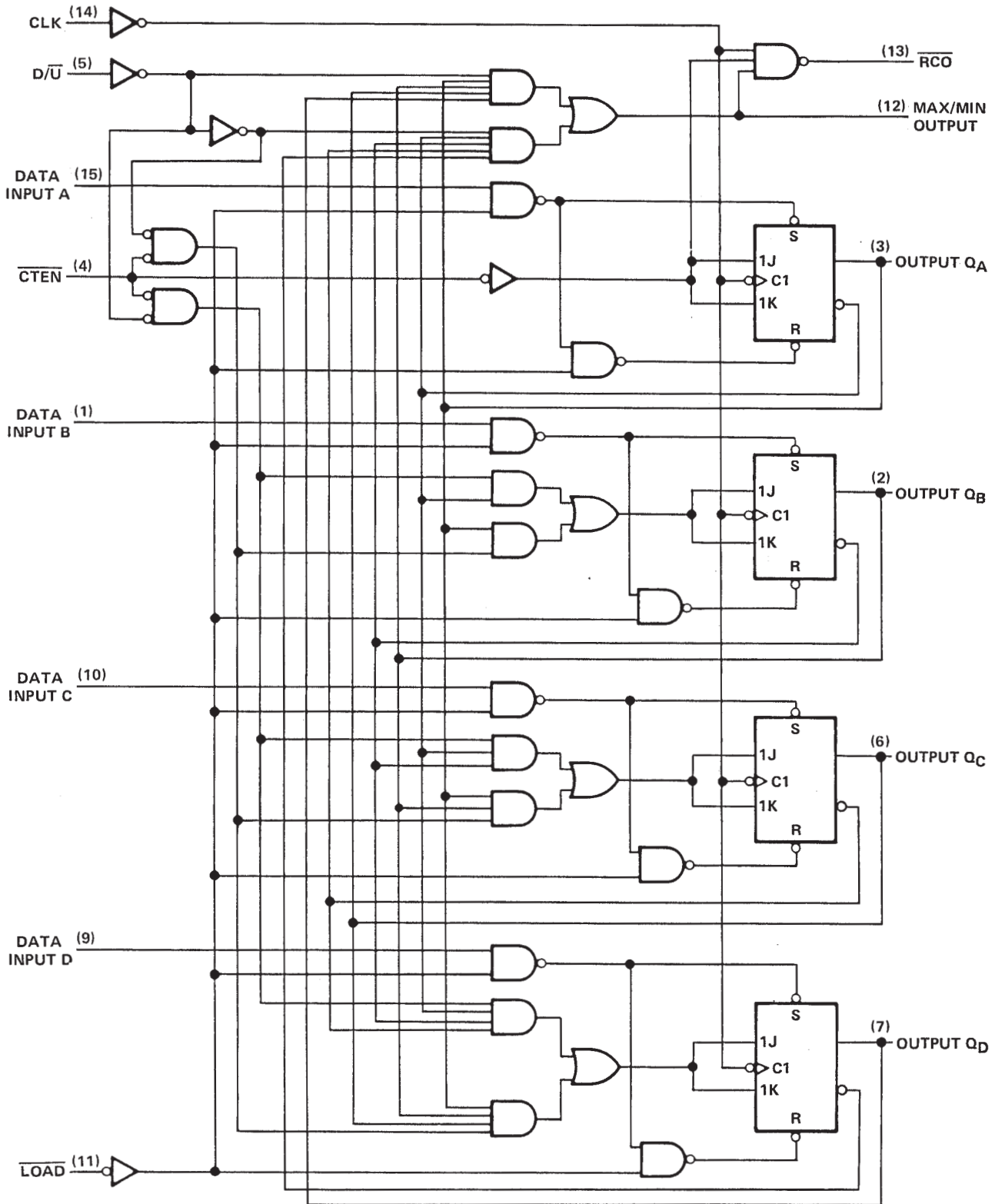

Pin numbers shown are for D, J, and N packages.



POST OFFICE BOX 655303 • DALLAS, TEXAS 75265

SN54190, SN54LS190, SN74190, SN74LS190 SYNCHRONOUS UP/DOWN COUNTERS WITH DOWN/UP MODE CONTROL

SDLS072 – DECEMBER 1972 – REVISED MARCH 1988

'190, 'LS190 DECADE COUNTERS

typical load, count, and inhibit sequences

Illustrated below is the following sequence:

1. Load (preset) to BCD seven.
2. Count up to eight, nine (maximum), zero, one, and two.
3. Inhibit.
4. Count down to one, zero (minimum), nine, eight, and seven.

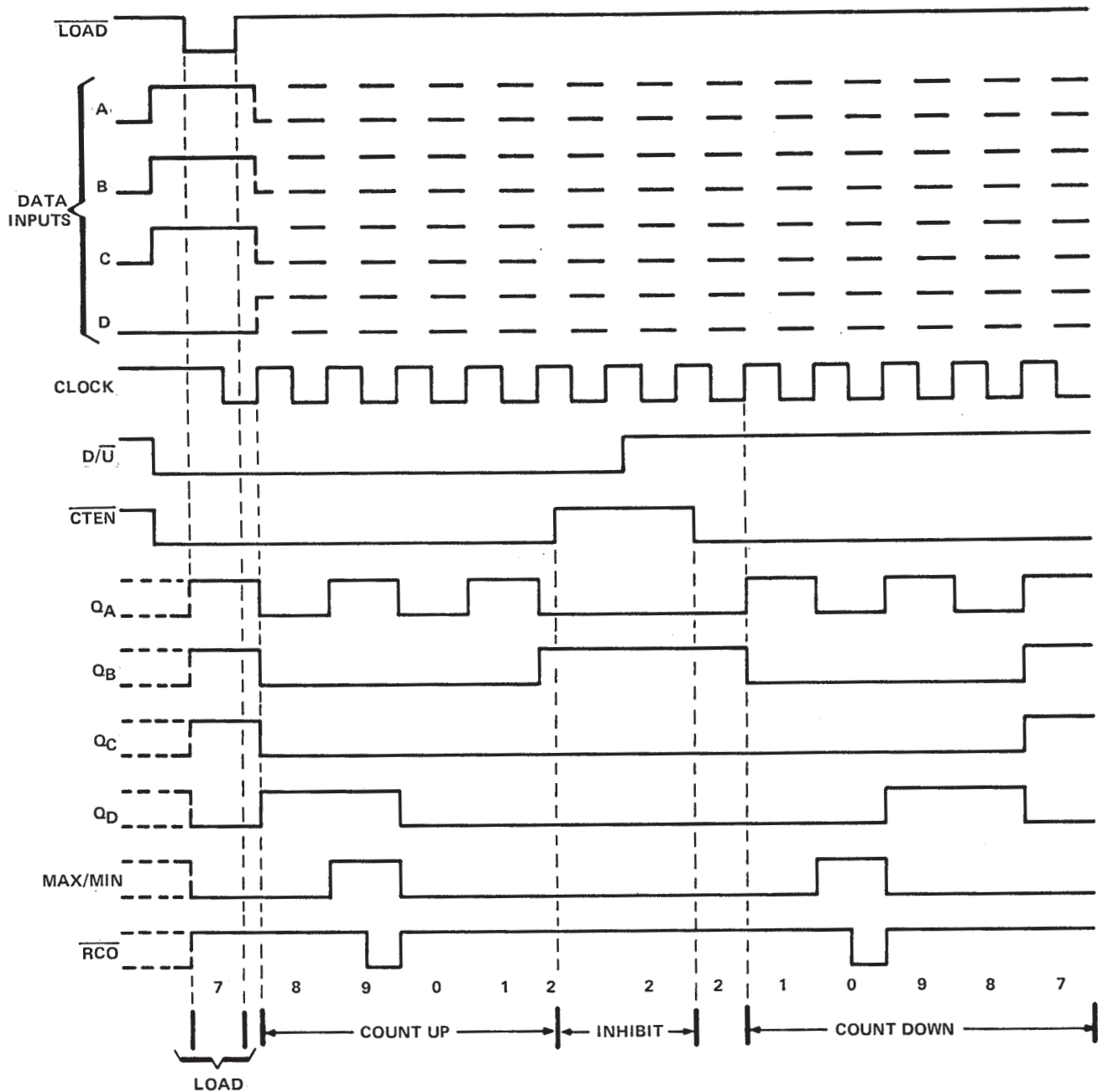

SN54191, SN54LS191, SN74191, SN74LS191 SYNCHRONOUS UP/DOWN COUNTERS WITH DOWN/UP MODE CONTROL

SDLS072 – DECEMBER 1972 – REVISED MARCH 1988

'191, 'LS191 BINARY COUNTERS

Typical load, count, and inhibit sequences

Illustrated below is the following sequence:

1. Load (preset) to binary thirteen.
2. Count up to fourteen, fifteen (maximum), zero, one, and two.
3. Inhibit.
4. Count down to one, zero (minimum), fifteen, fourteen, and thirteen.

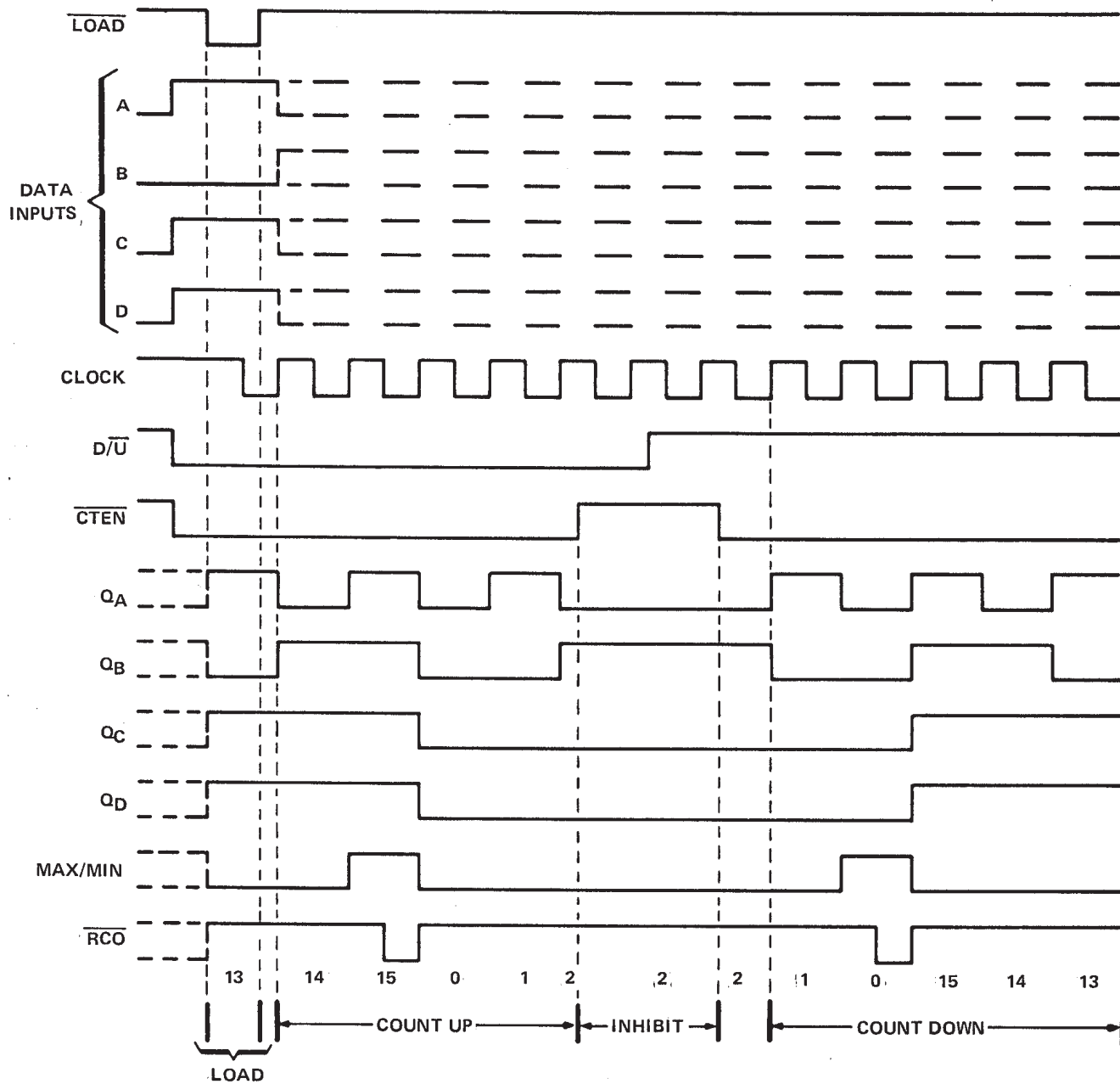

SN54190, SN54191, SN54LS190, SN54LS191, SN74190, SN74191, SN74LS190, SN74LS191 SYNCHRONOUS UP/DOWN COUNTERS WITH DOWN/UP MODE CONTROL

SDLS072 – DECEMBER 1972 – REVISED MARCH 1988

absolute maximum ratings over operating free-air temperature range (unless otherwise noted)

Supply voltage, V_{CC} (see Note 1)	7 V
Input voltage: SN54', SN74' Circuits	5.5 V
SN54LS', SN74LS' Circuits	7 V
Operating free-air temperature range: SN54', SN54LS' Circuits	-55°C to 125°C
SN74', SN74LS' Circuits	0°C to 70°C
Storage temperature range	-65°C to 150°C

NOTE 1: Voltage values are with respect to network ground terminal.

recommended operating conditions

		SN54190, SN54191			SN74190, SN74191			UNIT
		MIN	NOM	MAX	MIN	NOM	MAX	
V_{CC}	Supply voltage	4.5	5	5.5	4.75	5	5.25	V
I_{OH}	High-level output current			-0.8			-0.8	mA
I_{OL}	Low-level output current			16			16	mA
f_{clock}	Input clock frequency	0		20	0		20	MHz
$t_{w(clock)}$	Width of clock input pulse	25			25			ns
$t_{w(load)}$	Width of load input pulse	35			35			ns
t_{su}	Setup time	Data, high or low (See Figure 1 and 2)			20			ns
		Load inactive state			20			
t_{hold}	Data hold time	0			0			ns
T_A	Operating free-air temperature	-55		125	0		70	°C

electrical characteristics over recommended operating free-air temperature range (unless otherwise noted)

PARAMETER	TEST CONDITIONS†	SN54190, SN54191			SN74190, SN74191			UNIT	
		MIN	TYP‡	MAX	MIN	TYP‡	MAX		
V_{IH}	High-level input voltage	$V_{CC} = \text{MIN}$			2			V	
V_{IL}	Low-level input voltage	$V_{CC} = \text{MIN}$			0.8			V	
V_{IK}	Input clamp voltage	$V_{CC} = \text{MIN}, I_I = -12 \text{ mA}$			-1.5			V	
V_{OH}	High-level output voltage	$V_{CC} = \text{MIN}, V_{IH} = 2 \text{ V}, V_{IL} = 0.8 \text{ V}, I_{OH} = -0.8 \text{ mA}$			2.4	3.4		V	
V_{OL}	Low-level output voltage	$V_{CC} = \text{MIN}, V_{IH} = 2 \text{ V}, V_{IL} = 0.8 \text{ V}, I_{OL} = 16 \text{ mA}$			0.2	0.4		V	
I_I	High-level input current at maximum input voltage	$V_{CC} = \text{MAX}, V_I = 5.5 \text{ V}$			1			mA	
I_{IH}	High-level input current at any input except enable	$V_{CC} = \text{MAX}, V_I = 2.4 \text{ V}$			40			μA	
I_{IH}	High-level input current at enable input				120			μA	
I_{IL}	Low-level input current at any input except enable	$V_{CC} = \text{MAX}, V_I = 0.4 \text{ V}$			-1.6			mA	
I_{IL}	Low-level input current at enable input				-4.8			mA	
I_{OS}	Short-circuit output current§	$V_{CC} = \text{MAX}$			-20	-65	-18	-65	mA
I_{CC}	Supply current	$V_{CC} = \text{MAX},$ See Note 2			65	99	65	105	mA

† For conditions shown as MAX or MIN, use appropriate value specified under recommended operating conditions.

‡ All typical values are at $V_{CC} = 5 \text{ V}, T_A = 25^\circ\text{C}$.

§ Not more than one output should be shorted at a time.

NOTE 2: I_{CC} is measured with all inputs grounded and all outputs open.



SN54190, SN54191, SN74190, SN74191 SYNCHRONOUS UP/DOWN COUNTERS WITH DOWN/UP MODE CONTROL

SDLS072 – DECEMBER 1972 – REVISED MARCH 1988

switching characteristics, $V_{CC} = 5\text{ V}$, $T_A = 25^\circ\text{C}$

PARAMETER†	FROM (INPUT)	TO (OUTPUT)	TEST CONDITIONS	'190, '191			UNIT
				MIN	TYP	MAX	
f_{max}			$C_L = 15\text{ pF}$, $R_L = 400\ \Omega$, See Figures 1 and 3 thru 7	20	25		MHz
t_{PLH}	$\overline{\text{Load}}$	Q_A, Q_B, Q_C, Q_D			22	33	ns
t_{PHL}					33	50	
t_{PLH}	Data A, B, C, D	Q_A, Q_B, Q_C, Q_D			14	22	ns
t_{PHL}					35	50	
t_{PLH}	CLK	$\overline{\text{RCO}}$			13	20	ns
t_{PHL}					16	24	
t_{PLH}	CLK	Q_A, Q_B, Q_C, Q_D			16	24	ns
t_{PHL}					24	36	
t_{PLH}	CLK	Max/Min			28	42	ns
t_{PHL}					37	52	
t_{PLH}	D/\overline{U}	$\overline{\text{RCO}}$			30	45	ns
t_{PHL}					30	45	
t_{PLH}	D/\overline{U}	Max/Min			21	33	ns
t_{PHL}					22	33	

† f_{max} = maximum clock frequency
 t_{PLH} = propagation delay time, low-to-high-level output
 t_{PHL} = propagation delay time, high-to-low-level output

schematics of inputs and outputs

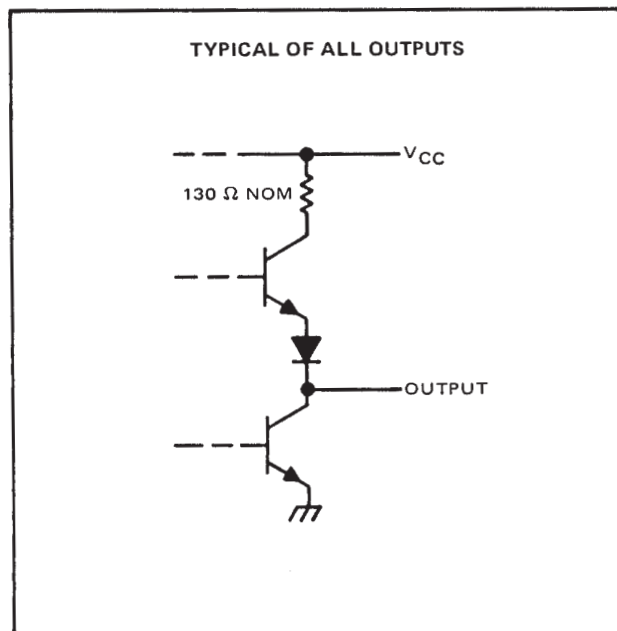
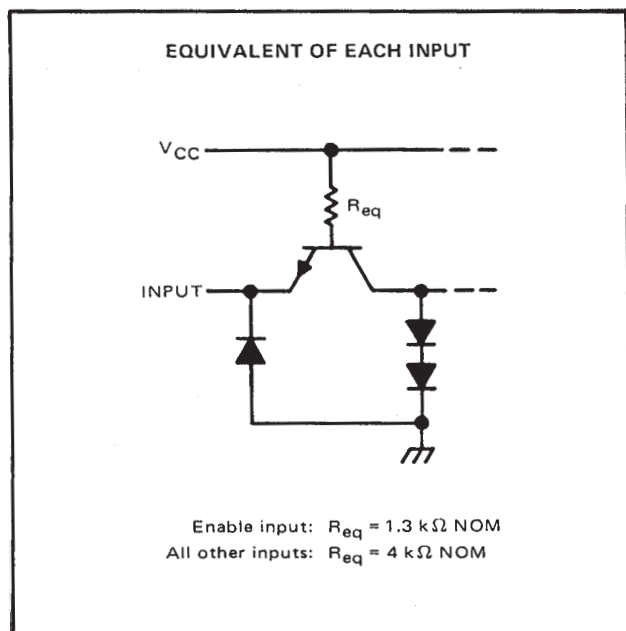

SN54LS190, SN54LS191, SN74LS190, SN74LS191 SYNCHRONOUS UP/DOWN COUNTERS WITH DOWN/UP MODE CONTROL

SDLS072 – DECEMBER 1972 – REVISED MARCH 1988

recommended operating conditions

		SN54LS190 SN54LS191			SN74LS190 SN74LS191			UNIT
		MIN	NOM	MAX	MIN	NOM	MAX	
V _{CC}	Supply voltage	4.5	5	5.5	4.75	5	5.25	V
I _{OH}	High-level output current			-0.4			-0.4	mA
I _{OL}	Low-level output current			4			8	mA
f _{clock}	Clock frequency	0		20	0		20	MHz
t _{w(clock)}	Width of clock input pulse	25			25			ns
t _{w(load)}	Width of load input pulse	35			35			ns
t _{su}	Data setup time (See Figures 1 and 2)	20			20			ns
t _{su}	Load inactive state setup time	30			30			ns
t _h	Data hold time	5			5			ns
t _h	Enable hold time	0			0			ns
t _{enable}	Count enable time (see Note 3)	40			40			ns
T _A	Operating free-air temperature	-55		125	0		70	°C

electrical characteristics over recommended operating free-air temperature range (unless otherwise noted)

PARAMETER		TEST CONDITIONS [†]	SN54LS190 SN54LS191			SN74LS190 SN74LS191			UNIT
			MIN	TYP [‡]	MAX	MIN	TYP [‡]	MAX	
V _{IH}	High-level input voltage		2			2		V	
V _{IL}	Low-level input voltage				0.7			0.8	
V _{IK}	Input clamp voltage	V _{CC} = MIN, I _I = -18 mA			-1.5			-1.5	
V _{OH}	High-level output voltage	V _{CC} = MIN, V _{IH} = 2 V, V _{IL} = V _{IL} max, I _{OH} = -400 μA	2.5	3.4		2.7	3.4	V	
V _{OL}	Low-level output voltage	V _{CC} = MIN, V _{IH} = 2 V, V _{IL} = V _{IL} max			0.25	0.4	0.25	0.4	
							0.35	0.5	
I _I	High-level input current at maximum input voltage	Enable			0.3			0.3	
		Others	V _{CC} = MAX, V _I = 7 V			0.1			0.1
I _{IH}	High-level input current	Enable			60			60	
		Others	V _{CC} = MAX, V _I = 2.7 V			20			20
I _{IL}	Low-level input current	Enable			-1.2			-1.2	
		Others	V _{CC} = MAX, V _I = 0.4 V			-0.4			-0.4
I _{OS}	Short-circuit output current [§]	V _{CC} = MAX,	-20	-100	-20	-100		mA	
I _{CC}	Supply current	V _{CC} = MAX, See Note 2	20	35	20	35		mA	

[†]For conditions shown as MAX or MIN, use appropriate value specified under recommended operating conditions for the applicable device type.

[‡]All typical values are at V_{CC} = 5 V, T_A = 25°C.

[§]Not more than one output should be shorted at a time, and duration of the short-circuit should not exceed one second.

NOTES: 2. I_{CC} is measured with all inputs grounded and all outputs open.

3. Minimum count enable time is the interval immediately preceding the rising edge of the clock pulse during which interval the count enable input must be low to ensure counting.



SN54LS190, SN54LS191, SN74LS190, SN74LS191

SYNCHRONOUS UP/DOWN COUNTERS WITH DOWN/UP MODE CONTROL

SDLS072 – DECEMBER 1972 – REVISED MARCH 1988

switching characteristics, $V_{CC} = 5\text{ V}$, $T_A = 25^\circ\text{C}$

PARAMETER†	FROM (INPUT)	TO (OUTPUT)	TEST CONDITIONS	'LS190, 'LS191			UNIT
				MIN	TYP	MAX	
f_{max}			$C_L = 15\text{ pF}$, $R_L = 2\text{ k}\Omega$, See Figures 1 and 3 thru 7	20	25		MHz
t_{PLH}	Load	Q_A, Q_B, Q_C, Q_D		22	33	ns	
t_{PHL}				33	50		
t_{PLH}	Data A, B, C, D	Q_A, Q_B, Q_C, Q_D		20	32	ns	
t_{PHL}				27	40		
t_{PLH}	CLK	\overline{RCO}		13	20	ns	
t_{PHL}				16	24		
t_{PLH}	CLK	Q_A, Q_B, Q_C, Q_D		16	24	ns	
t_{PHL}				24	36		
t_{PLH}	CLK	Max/Min		28	42	ns	
t_{PHL}				37	52		
t_{PLH}	D/\overline{U}	\overline{RCO}		30	45	ns	
t_{PHL}				30	45		
t_{PLH}	D/\overline{U}	Max/Min		21	33	ns	
t_{PHL}				22	33		
t_{PLH}	\overline{CTEN}	\overline{RCO}		21	33	ns	
t_{PHL}				22	33		

- † f_{max} ≡ maximum clock frequency
- t_{PLH} ≡ propagation delay time, low-to-high-level output
- t_{PHL} ≡ propagation delay time, high-to-low-level output

schematics of inputs and outputs

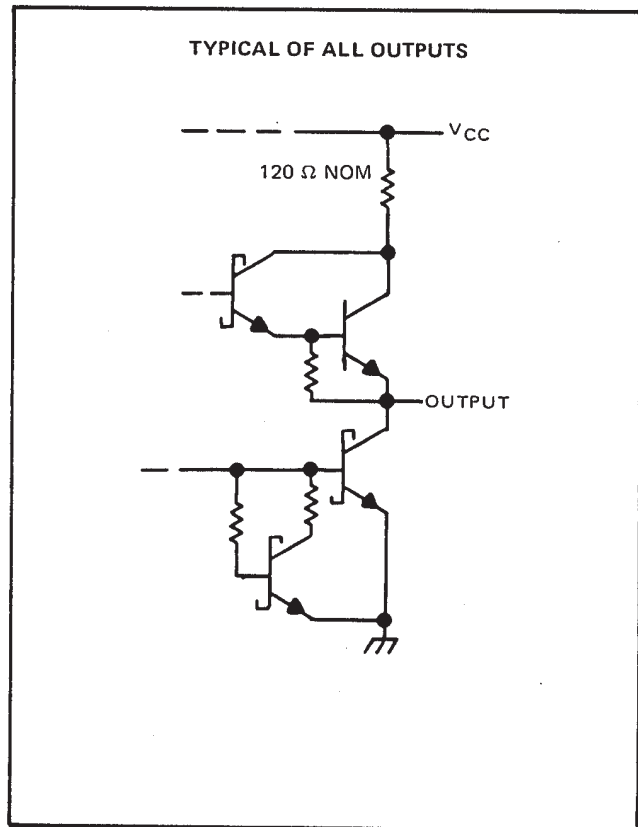
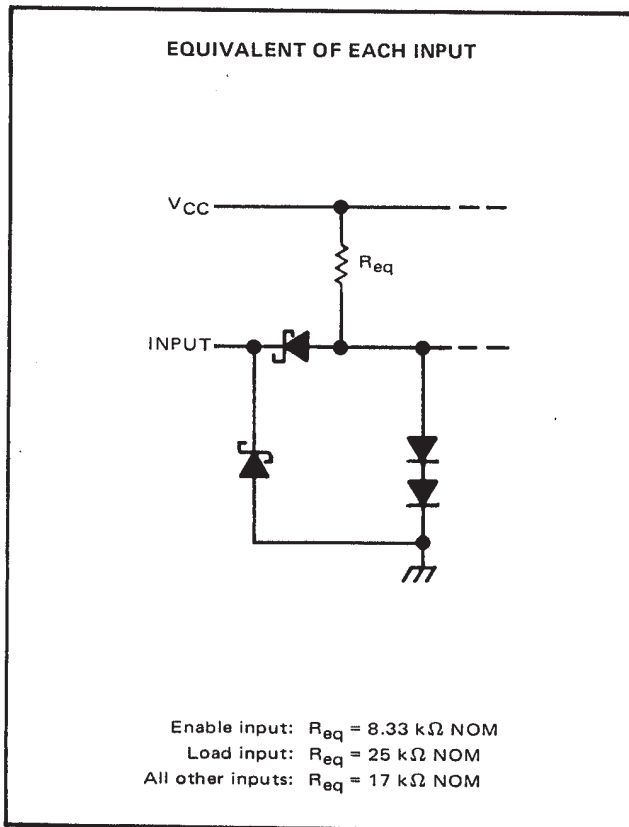

SN54190, SN54191, SN54LS190, SN54LS191,
SN74190, SN74191, SN74LS190, SN74LS191
SYNCHRONOUS UP/DOWN COUNTERS WITH DOWN/UP MODE CONTROL

SDLS072 - DECEMBER 1972 - REVISED MARCH 1988

PARAMETER MEASUREMENT INFORMATION

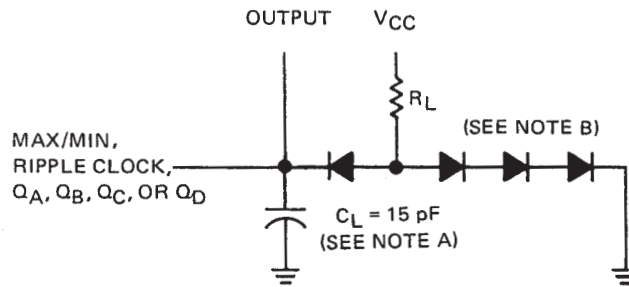

**FIGURE 1—LOAD CIRCUIT
FOR SWITCHING TIME MEASUREMENT**

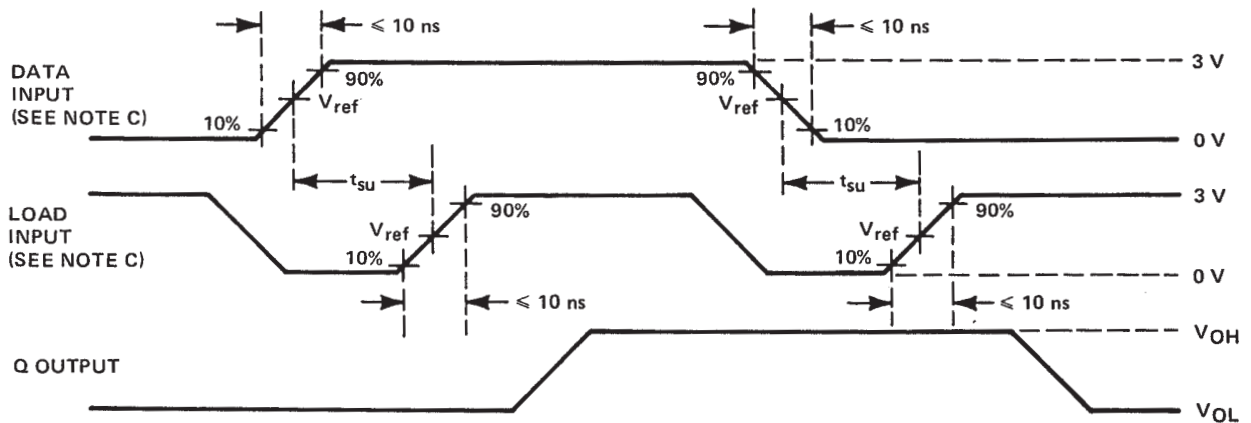
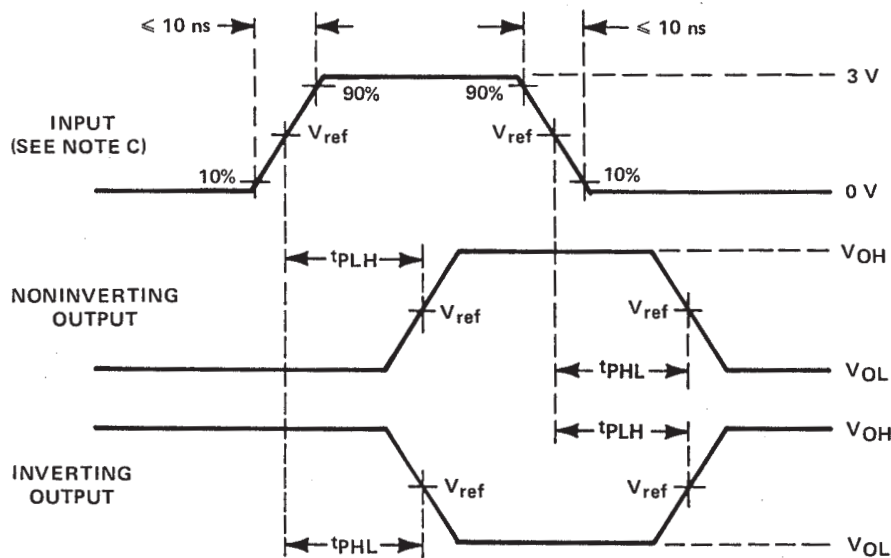

FIGURE 2—DATA SETUP TIME VOLTAGE WAVEFORMS



See waveform sequences in figures 4 through 7 for propagation times from a specific input to a specific output. For simplification, pulse rise times, reference levels, etc., have not been shown in figures 4 through 7.

FIGURE 3—GENERAL VOLTAGE WAVEFORMS FOR PROPAGATION TIMES

- NOTES: A. C_L includes probe and jig capacitance.
B. All diodes are 1N3064 or equivalent.
C. The input pulses are supplied by generators having the following characteristics: $Z_{out} = 50 \Omega$, duty cycle $\leq 50\%$, PRR $\leq 1\text{ MHz}$.
D. $V_{ref} = 1.5\text{ V}$ for '190 and '191; 1.3 V for 'LS190 and 'LS191.

SN54190, SN54191, SN54LS190, SN54LS191,
 SN74190, SN74191, SN74LS190, SN74LS191
 SYNCHRONOUS UP/DOWN COUNTERS WITH DOWN/UP MODE CONTROL

SDLS072 – DECEMBER 1972 – REVISED MARCH 1988

PARAMETER MEASUREMENT INFORMATION (continued)

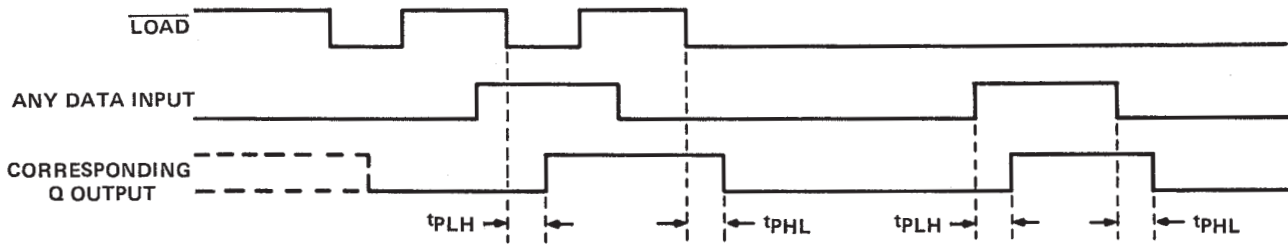

NOTE E: Conditions on other inputs are irrelevant.

FIGURE 4—LOAD TO OUTPUT AND DATA TO OUTPUT

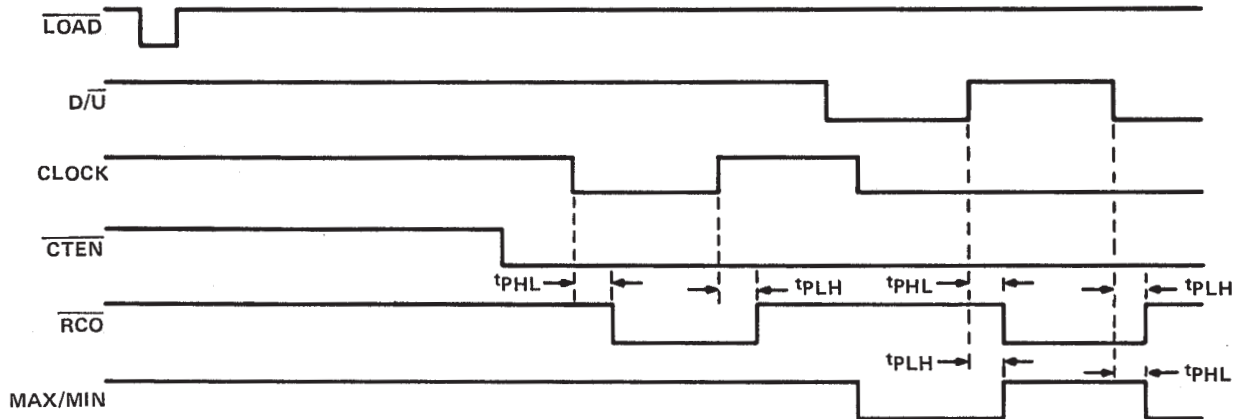

NOTE F: All data inputs are low.

FIGURE 5—ENABLE TO RIPPLE CLOCK, CLOCK TO RIPPLE CLOCK, DOWN/UP TO RIPPLE CLOCK, AND DOWN/UP TO MAX/MIN

SN54190, SN54191, SN54LS190, SN54LS191,
SN74190, SN74191, SN74LS190, SN74LS191
SYNCHRONOUS UP/DOWN COUNTERS WITH DOWN/UP MODE CONTROL

SDLS072 - DECEMBER 1972 - REVISED MARCH 1988

PARAMETER MEASUREMENT INFORMATION (continued)

switching characteristics (continued)

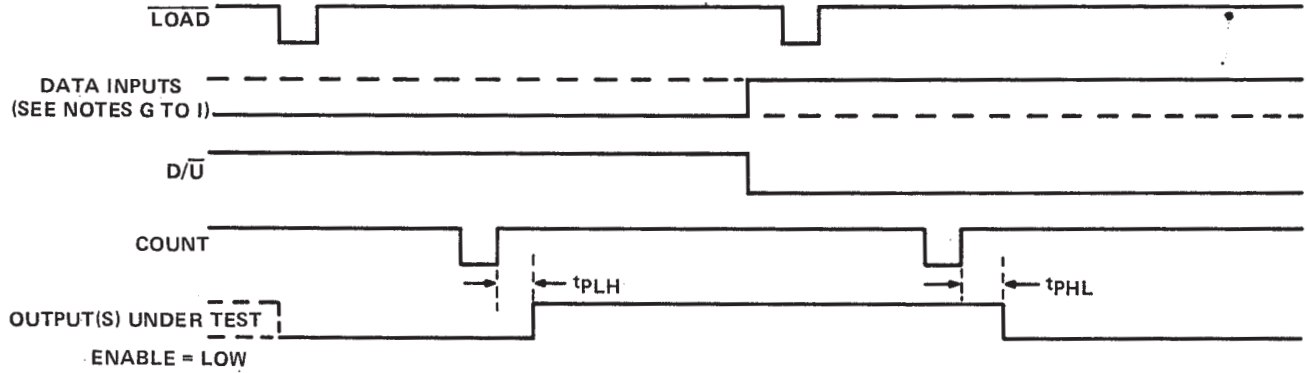

- NOTES: G. To test Q_A , Q_B , and Q_C outputs of '190 and 'LS190: Data inputs A, B, and C are shown by the solid line. Data input D is shown by the dashed line.
H. To test Q_D output of '190 and 'LS190: Data inputs A and D are shown by the solid line. Data inputs B and C are held at the low logic level.
I. To test Q_A , Q_B , Q_C , and Q_D outputs of '191 and 'LS191: All four data inputs are shown by the solid line.

FIGURE 6-CLOCK TO OUTPUT

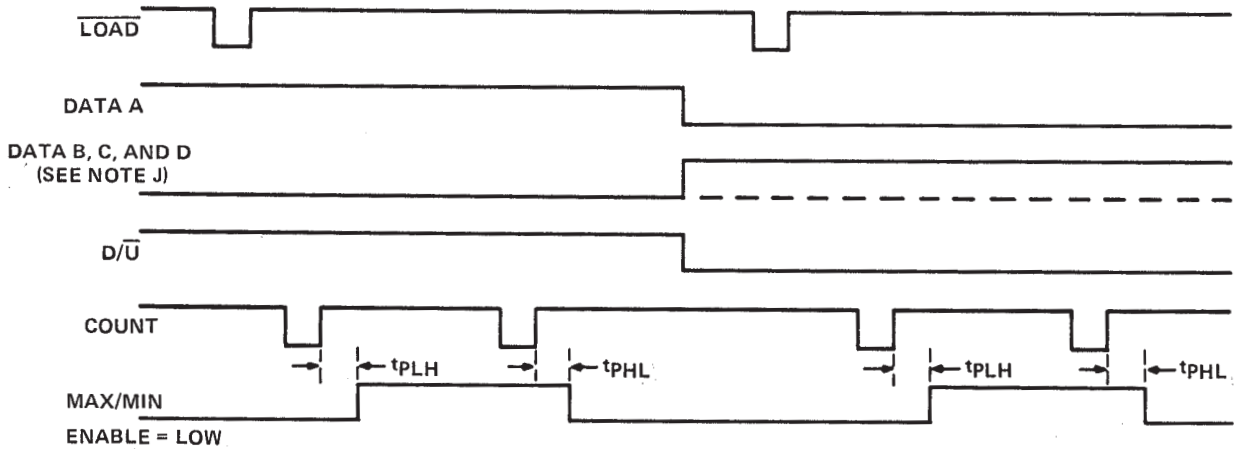

- NOTE J: Data inputs B and C are shown by the dashed line for the '190 and 'LS190 and the solid line for the '191 and 'LS191: Data input D is shown by the solid line for both devices.

FIGURE 7-CLOCK TO MAX/MIN

IMPORTANT NOTICE

Texas Instruments and its subsidiaries (TI) reserve the right to make changes to their products or to discontinue any product or service without notice, and advise customers to obtain the latest version of relevant information to verify, before placing orders, that information being relied on is current and complete. All products are sold subject to the terms and conditions of sale supplied at the time of order acknowledgement, including those pertaining to warranty, patent infringement, and limitation of liability.

TI warrants performance of its semiconductor products to the specifications applicable at the time of sale in accordance with TI's standard warranty. Testing and other quality control techniques are utilized to the extent TI deems necessary to support this warranty. Specific testing of all parameters of each device is not necessarily performed, except those mandated by government requirements.

CERTAIN APPLICATIONS USING SEMICONDUCTOR PRODUCTS MAY INVOLVE POTENTIAL RISKS OF DEATH, PERSONAL INJURY, OR SEVERE PROPERTY OR ENVIRONMENTAL DAMAGE ("CRITICAL APPLICATIONS"). TI SEMICONDUCTOR PRODUCTS ARE NOT DESIGNED, AUTHORIZED, OR WARRANTED TO BE SUITABLE FOR USE IN LIFE-SUPPORT DEVICES OR SYSTEMS OR OTHER CRITICAL APPLICATIONS. INCLUSION OF TI PRODUCTS IN SUCH APPLICATIONS IS UNDERSTOOD TO BE FULLY AT THE CUSTOMER'S RISK.

In order to minimize risks associated with the customer's applications, adequate design and operating safeguards must be provided by the customer to minimize inherent or procedural hazards.

TI assumes no liability for applications assistance or customer product design. TI does not warrant or represent that any license, either express or implied, is granted under any patent right, copyright, mask work right, or other intellectual property right of TI covering or relating to any combination, machine, or process in which such semiconductor products or services might be or are used. TI's publication of information regarding any third party's products or services does not constitute TI's approval, warranty or endorsement thereof.