

SN54174, SN54175, SN54LS174, SN54LS175, SN54S174, SN54S175, SN74174, SN74175, SN74LS174, SN74LS175, SN74S174, SN74S175 HEX/QUADRUPLE D-TYPE FLIP-FLOPS WITH CLEAR

SDLS068A – DECEMBER 1972 – REVISED OCTOBER 2001

'174, 'LS174, 'S174 ... HEX D-TYPE FLIP-FLOPS
'175, 'LS175, 'S175 ... QUADRUPLE D-TYPE FLIP-FLOPS

- '174, 'LS174, 'S174 Contain Six Flip-Flops with Single-Rail Outputs
- '175, 'LS175, 'S175 Contain Four Flip-Flops with Double-Rail Outputs
- Three Performance Ranges Offered: See Table Lower Right
- Buffered Clock and Direct Clear Inputs
- Individual Data Input to Each Flip-Flop
- Applications include:
 - Buffer/Storage Registers
 - Shift Registers
 - Pattern Generators

SN54174, SN54LS174, SN54S174 ... J OR W PACKAGE
SN74174 ... N PACKAGE
SN74LS174, SN74S174 ... D OR N PACKAGE

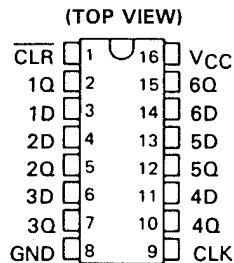

SN54LS174, SN54S174 ... FK PACKAGE
(TOP VIEW)

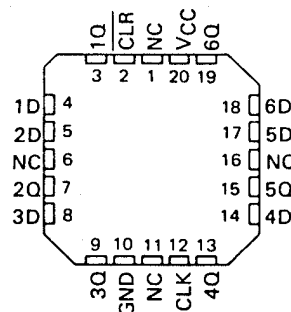

SN54175, SN54LS175, SN54S175 ... J OR W PACKAGE
SN74175 ... N PACKAGE
SN74LS175, SN74S175 ... D OR N PACKAGE

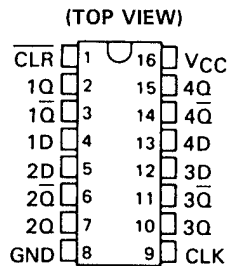

SN54LS175, SN54S175 ... FK PACKAGE
(TOP VIEW)

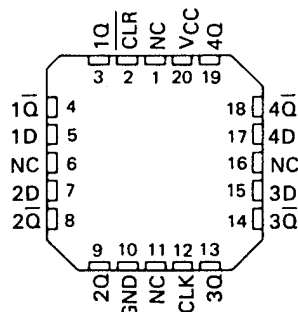

NC – No internal connection

description

These monolithic, positive-edge-triggered flip-flops utilize TTL circuitry to implement D-type flip-flop logic. All have a direct clear input, and the '175, 'LS175, and 'S175 feature complementary outputs from each flip-flop.

Information at the D inputs meeting the setup time requirements is transferred to the Q outputs on the positive-going edge of the clock pulse. Clock triggering occurs at a particular voltage level and is not directly related to the transition time of the positive-going pulse. When the clock input is at either the high or low level, the D input signal has no effect at the output.

These circuits are fully compatible for use with most TTL circuits.

FUNCTION TABLE
(EACH FLIP-FLOP)

INPUTS			OUTPUTS	
CLEAR	CLOCK	D	Q	Q̄†
L	X	X	L	H
H	↑	H	H	L
H	↑	L	L	H
H	L	X	Q ₀	Q̄ ₀

H = high level (steady state)

L = low level (steady state)

X = irrelevant

↑ = transition from low to high level

Q₀ = the level of Q before the indicated steady-state input conditions were established.

† = '175, 'LS175, and 'S175 only

TYPES	TYPICAL	TYPICAL
	MAXIMUM	POWER
	CLOCK	DISSIPATION
	FREQUENCY	PER FLIP-FLOP
'174, '175	35 MHz	38 mW
'LS174, 'LS175	40 MHz	14 mW
'S174, 'S175	110 MHz	75 mW

PRODUCTION DATA information is current as of publication date. Products conform to specifications per the terms of Texas Instruments standard warranty. Production processing does not necessarily include testing of all parameters.

 **TEXAS
INSTRUMENTS**

POST OFFICE BOX 655303 • DALLAS, TEXAS 75265

Copyright © 2001, Texas Instruments Incorporated

SN54174, SN54175, SN54LS174, SN54LS175, SN54S174, SN54S175, SN74174, SN74175, SN74LS174, SN74LS175, SN74S174, SN74S175 HEX/QUADRUPLE D-TYPE FLIP-FLOPS WITH CLEAR

SDLS068A – DECEMBER 1972 – REVISED OCTOBER 2001

logic symbols†

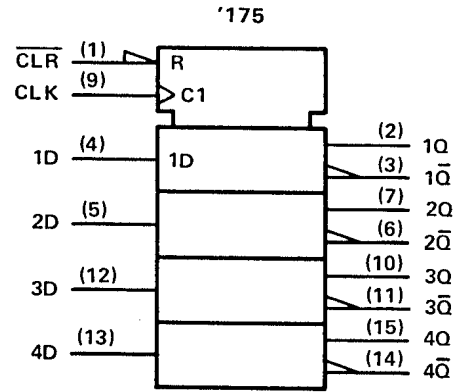
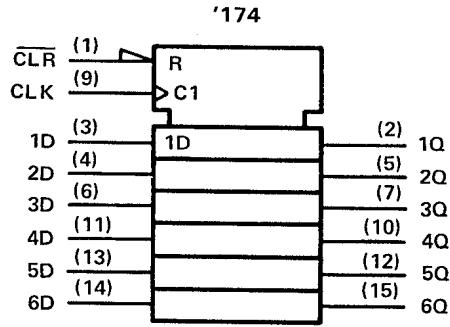

†These symbols are in accordance with ANSI/IEEE Std. 91-1984 and IEC Publication 617-12. Pin numbers shown are for D, J, N, and W packages.

logic diagrams (positive logic)

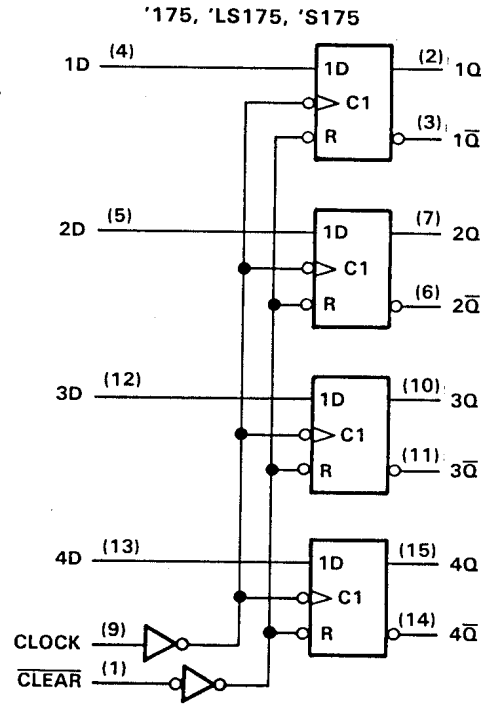
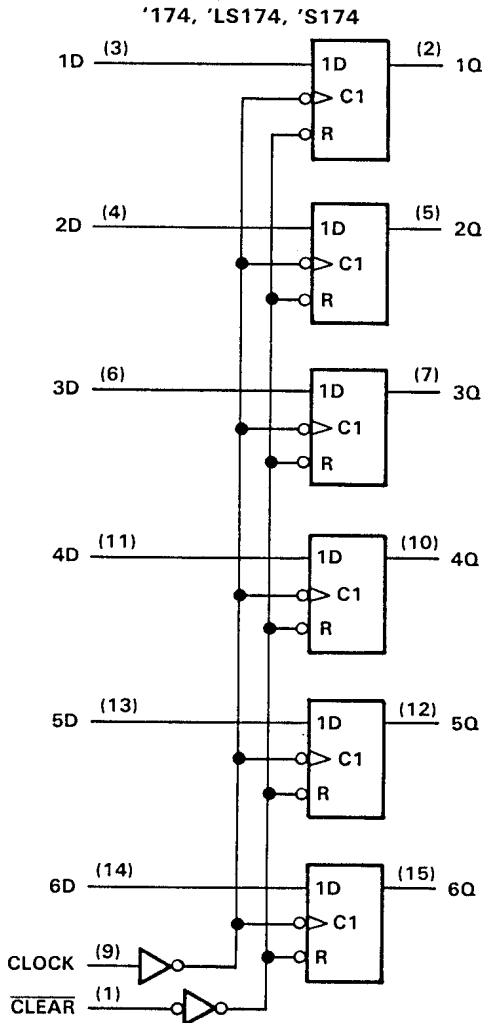

Pin numbers shown are for D, J, N, and W packages.



POST OFFICE BOX 655303 • DALLAS, TEXAS 75265

SN54174, SN54175, SN54LS174, SN54LS175, SN54S174, SN54S175,
 SN74174, SN74175, SN74LS174, SN74LS175, SN74S174, SN74S175
 HEX/QUADRUPLE D-TYPE FLIP-FLOPS WITH CLEAR

SDLS068A - DECEMBER 1972 - REVISED OCTOBER 2001

schematics of inputs and outputs

SN54174, SN54175, SN74174, SN74175

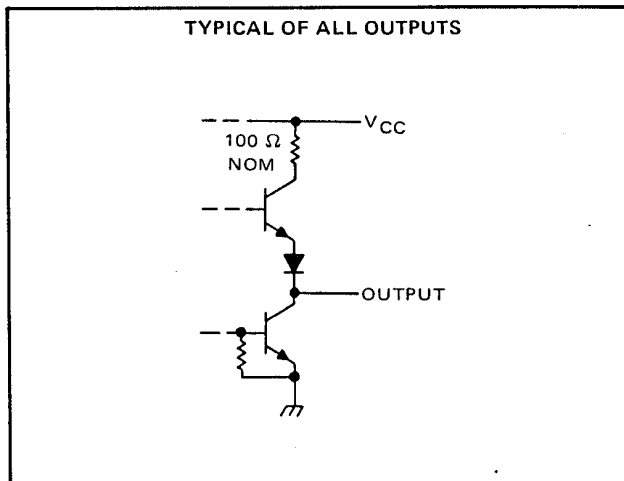
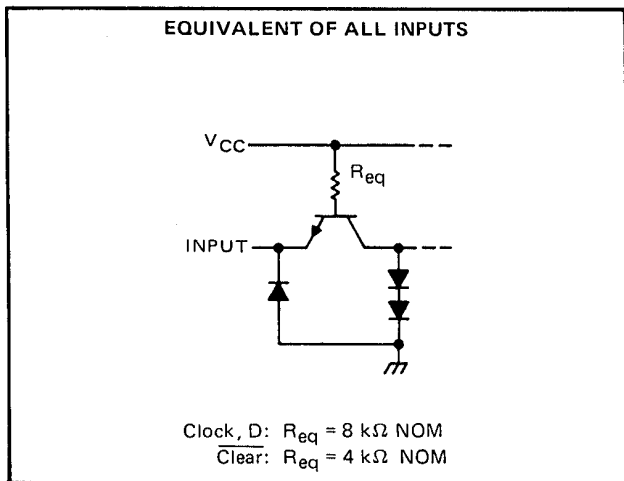

SN54LS174, SN54LS175, SN74LS174, SN74LS175

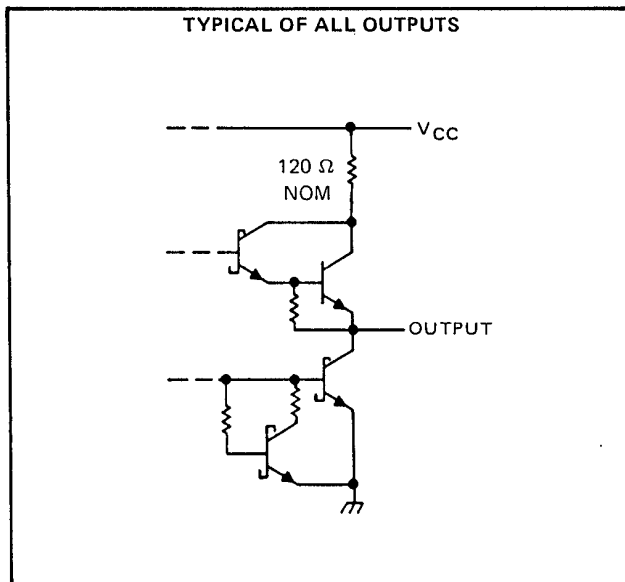
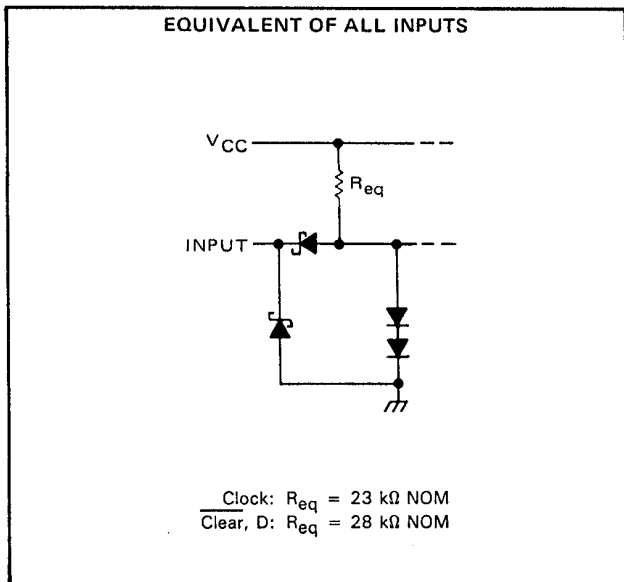

SN54S174, SN54S175, SN74S174, SN74S175

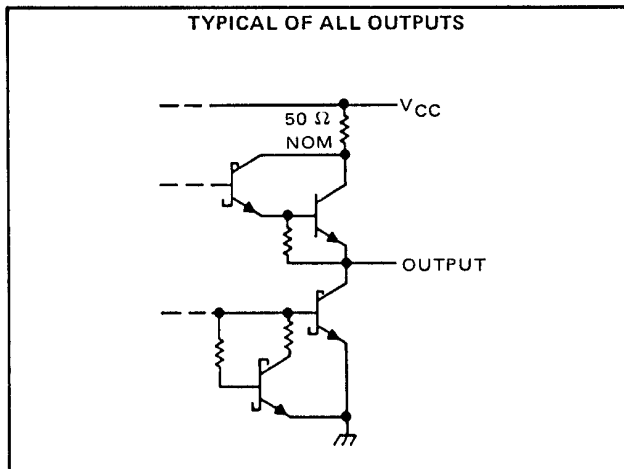
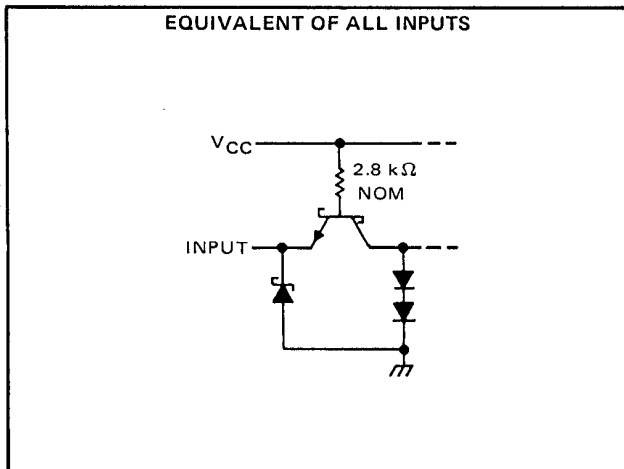

SN54LS174, SN54LS175, SN74LS174, SN74LS175 HEX/QUADRUPLE D-TYPE FLIP-FLOPS WITH CLEAR

SDLS068A – DECEMBER 1972 – REVISED OCTOBER 2001

absolute maximum ratings over operating free-air temperature range (unless otherwise noted)

Supply voltage, V_{CC} (see Note 1)	7 V
Input voltage	7 V
Operating free-air temperature range: SN54LS174, SN54LS175 Circuits	-55°C to 125°C
SN74LS174, SN74LS175 Circuits	0°C to 70°C
Storage temperature range	-65°C to 150°C

NOTE 1: Voltage values are with respect to network ground terminal.

recommended operating conditions

	SN54LS174 SN54LS175			SN74LS174 SN74LS175			UNIT
	MIN	NOM	MAX	MIN	NOM	MAX	
Supply voltage, V_{CC}	4.5	5	5.5	4.75	5	5.25	V
High-level output current, I_{OH}			-400			-400	μ A
Low-level output current, I_{OL}			4			8	mA
Clock frequency, f_{clock}	0		30	0		30	MHz
Width of clock or clear pulse, t_W	20			20			ns
Setup time, t_{su}	Data input	20		20			ns
	Clear inactive-state	25		25			ns
Data hold time, t_h	5			5			ns
Operating free-air temperature, T_A	-55		125	0		70	°C

electrical characteristics over recommended operating free-air temperature range (unless otherwise noted)

PARAMETER	TEST CONDITIONS†	SN54LS174 SN54LS175			SN74LS174 SN74LS175			UNIT
		MIN	TYP‡	MAX	MIN	TYP‡	MAX	
V_{IH} High-level input voltage		2			2			V
V_{IL} Low-level input voltage				0.7			0.8	V
V_{IK} Input clamp voltage	$V_{CC} = \text{MIN}, I_I = -18 \text{ mA}$			-1.5			-1.5	V
V_{OH} High-level output voltage	$V_{CC} = \text{MIN}, V_{IH} = 2 \text{ V},$ $V_{IL} = V_{IL \text{ max}}, I_{OH} = -400 \mu\text{A}$	2.5	3.5		2.7	3.5		V
V_{OL} Low-level output voltage	$V_{CC} = \text{MIN}, V_{IH} = 2 \text{ V},$ $V_{IL} = V_{IL \text{ max}}$	$I_{OL} = 4 \text{ mA}$	0.25	0.4	0.25	0.4		V
		$I_{OL} = 8 \text{ mA}$			0.35	0.5		
I_I Input current at maximum input voltage	$V_{CC} = \text{MAX}, V_I = 7 \text{ V}$			0.1			0.1	mA
I_{IH} High-level input current	$V_{CC} = \text{MAX}, V_I = 2.7 \text{ V}$			20			20	μ A
I_{IL} Low-level input current	$V_{CC} = \text{MAX}, V_I = 0.4 \text{ V}$			-0.4			-0.4	mA
I_{OS} Short-circuit output current §	$V_{CC} = \text{MAX}$	-20		-100	-20		-100	mA
I_{CC} Supply current	$V_{CC} = \text{MAX},$ See Note 2	'LS174	16	26	16	26		mA
		'LS175	11	18	11	18		

† For conditions shown as MIN or MAX, use the appropriate value specified under recommended operating conditions.

‡ All typical values are at $V_{CC} = 5 \text{ V}, T_A = 25^\circ\text{C}$.

§ Not more than one output should be shorted at a time, and duration of the short-circuit should not exceed one second.

NOTE 2: With all outputs open and 4.5 V applied to all data and clear inputs, I_{CC} is measured after a momentary ground, then 4.5 V, is applied to clock.

switching characteristics, $V_{CC} = 5 \text{ V}, T_A = 25^\circ\text{C}$

PARAMETER	TEST CONDITIONS	'LS174			'LS175			UNIT
		MIN	TYP	MAX	MIN	TYP	MAX	
f_{max} Maximum clock frequency	$C_L = 15 \text{ pF},$ $R_L = 2 \text{ k}\Omega,$ See Note 3	30	40		30	40		MHz
t_{PLH} Propagation delay time, low-to-high-level output from clear					20	30		ns
t_{PHL} Propagation delay time, high-to-low-level output from clear			23	35	20	30		ns
t_{PLH} Propagation delay time, low-to-high-level output from clock			20	30	13	25		ns
t_{PHL} Propagation delay time, high-to-low-level output from clock			21	30	16	25		ns

NOTE 3: Load circuits and voltage waveforms are shown in Section 1.



SN54S174, SN54S175, SN74S174, SN74S175 HEX/QUADRUPLE D-TYPE FLIP-FLOPS WITH CLEAR

SDLS068A – DECEMBER 1972 – REVISED OCTOBER 2001

absolute maximum ratings over operating free-air temperature range (unless otherwise noted)

Supply voltage, V_{CC} (see Note 1)	7 V
Input voltage	5.5 V
Operating free-air temperature range: SN54S174, SN54S175 Circuits	-55°C to 125°C
SN74S174, SN74S175 Circuits	0°C to 70°C
Storage temperature range	-65°C to 150°C

NOTE 1: Voltage values are with respect to network ground terminal.

recommended operating conditions

	SN54S174, SN54S175			SN74S174, SN74S175			UNIT
	MIN	NOM	MAX	MIN	NOM	MAX	
Supply voltage, V_{CC}	4.5	5	5.5	4.75	5	5.25	V
High-level output current, I_{OH}			-1			-1	mA
Low-level output current, I_{OL}			20			20	mA
Clock frequency, f_{clock}	0		75	0		75	MHz
Pulse width, t_w	Clock		7			7	ns
	Clear		10			10	
Setup time, t_{su}	Data input		5			5	ns
	Clear inactive-state		5			5	
Data hold time, t_h			3			3	ns
Operating free-air temperature, T_A	-55		125	0		70	°C

electrical characteristics over recommended operating free-air temperature range (unless otherwise noted)

PARAMETER	TEST CONDITIONS†	MIN	TYP‡	MAX	UNIT
V_{IH} High-level input voltage		2			V
V_{IL} Low-level input voltage				0.8	V
V_{IK} Input clamp voltage	$V_{CC} = \text{MIN}, I_I = -18 \text{ mA}$			-1.2	V
V_{OH} High-level output voltage	$V_{CC} = \text{MIN}, V_{IH} = 2 \text{ V},$ $V_{IL} = 0.8 \text{ V}, I_{OH} = -1 \text{ mA}$	SN54S'	2.5	3.4	V
		SN74S'	2.7	3.4	
V_{OL} Low-level output voltage	$V_{CC} = \text{MIN}, V_{IH} = 2 \text{ V},$ $V_{IL} = 0.8 \text{ V}, I_{OL} = 20 \text{ mA}$			0.5	V
I_I Input current at maximum input voltage	$V_{CC} = \text{MAX}, V_I = 5.5 \text{ V}$			1	mA
I_{IH} High-level input current	$V_{CC} = \text{MAX}, V_I = 2.7 \text{ V}$			50	µA
I_{IL} Low-level input current	$V_{CC} = \text{MAX}, V_I = 0.5 \text{ V}$			-2	mA
I_{OS} Short-circuit output current §	$V_{CC} = \text{MAX}$	-40		-100	mA
I_{CC} Supply current	$V_{CC} = \text{MAX}, \text{ See Note 2}$	'174	90	144	mA
		'175	60	96	

† For conditions shown as MIN or MAX, use the appropriate value specified under recommended operating conditions for the applicable device type.

‡ All typical values are at $V_{CC} = 5 \text{ V}, T_A = 25^\circ\text{C}$.

§ Not more than one output should be shorted at a time, and duration of the short-circuit should not exceed one second.

NOTE 2: With all outputs open and 4.5 V applied to all data and clear inputs, I_{CC} is measured after a momentary ground, then 4.5 V, is applied to clock.

switching characteristics, $V_{CC} = 5 \text{ V}, T_A = 25^\circ\text{C}$

PARAMETER	TEST CONDITIONS	MIN	TYP	MAX	UNIT
f_{max} Maximum clock frequency		75	110		MHz
t_{PLH} Propagation delay time, low-to-high-level \bar{Q} output from clear (SN54S175, SN74S175 only)	$C_L = 15 \text{ pF},$ $R_L = 280 \Omega,$ See Note 3		10	15	ns
t_{PHL} Propagation delay time, high-to-low-level Q output from clear			13	22	ns
t_{PLH} Propagation delay time, low-to-high-level output from clock			8	12	ns
t_{PHL} Propagation time, high-to-low-level output from clock			11.5	17	ns

NOTE 3: Load circuits and voltage waveforms are shown in Section 1.

