

SN54125, SN54126, SN54LS125A, SN54LS126A, SN74125, SN74126, SN74LS125A, SN74LS126A QUADRUPLE BUS BUFFERS WITH 3-STATE OUTPUTS

SDLS044A - DECEMBER 1983 - REVISED MARCH 2002

The SN54125, SN54126, SN74125, SN74126, and SN54LS126A are obsolete and are no longer supplied.

- Quad Bus Buffers
- 3-State Outputs
- Separate Control for Each Channel

description

These bus buffers feature three-state outputs that, when enabled, have the low impedance characteristics of a TTL output with additional drive capability at high logic levels to permit driving heavily loaded bus lines without external pullup resistors. When disabled, both output transistors are turned off, presenting a high-impedance state to the bus so the output will act neither as a significant load nor as a driver. The '125 and 'LS125A devices' outputs are disabled when \bar{G} is high. The '126 and 'LS126A devices' outputs are disabled when G is low.

SN54125, SN54126, SN54LS125A,
SN54LS126A . . . J OR W PACKAGE
SN74125, SN74126 . . . N PACKAGE
SN74LS125A, SN74LS126A . . . D, N, OR NS PACKAGE
(TOP VIEW)

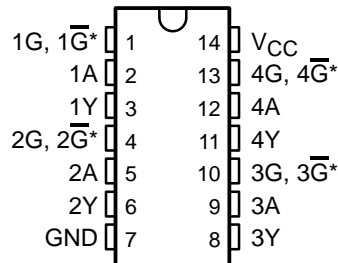

\bar{G} on '125 and 'LS125A devices;
G on 126 and 'LS126A devices

SN54LS125A, SN54LS126A . . . FK PACKAGE
(TOP VIEW)

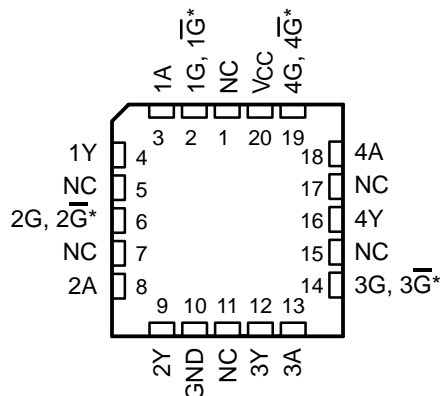

\bar{G} on '125 and 'LS125A devices;
G on 126 and 'LS126A devices
NC - No internal connection



Please be aware that an important notice concerning availability, standard warranty, and use in critical applications of Texas Instruments semiconductor products and disclaimers thereto appears at the end of this data sheet.

PRODUCTION DATA information is current as of publication date. Products conform to specifications per the terms of Texas Instruments standard warranty. Production processing does not necessarily include testing of all parameters.

 **TEXAS
INSTRUMENTS**

POST OFFICE BOX 655303 • DALLAS, TEXAS 75265

Copyright © 2002, Texas Instruments Incorporated
On products compliant to MIL-PRF-38535, all parameters are tested unless otherwise noted. On all other products, production processing does not necessarily include testing of all parameters.

**SN54125, SN54126, SN54LS125A, SN54LS126A,
SN74125, SN74126, SN74LS125A, SN74LS126A
QUADRUPLE BUS BUFFERS WITH 3-STATE OUTPUTS**

SDLS044A – DECEMBER 1983 – REVISED MARCH 2002

The SN54125, SN54126, SN74125,
SN74126, and SN54LS126A are
obsolete and are no longer supplied.

ORDERING INFORMATION

T _A	PACKAGE†		ORDERABLE PART NUMBER	TOP-SIDE MARKING
0°C to 70°C	PDIP – N	Tube	SN74LS125AN	SN74LS125AN
		Tube	SN74LS126AN	SN74LS126AN
	SOIC – D	Tube	SN74LS125AD	LS125A
		Tape and reel	SN74LS125ADR	
		Tube	SN74LS126AD	LS126A
		Tape and reel	SN74LS126ADR	
	SOP – NS	Tape and reel	SN74LS125ANSR	74LS125A
Tape and reel		SN74LS126ANSR	74LS126A	
–55°C to 125°C	CDIP – J	Tube	SN54LS125AJ	SN54LS125AJ
		Tube	SNJ54LS125AJ	SNJ54LS125AJ
	CFP – W	Tube	SNJ54LS125AW	SNJ54LS125AW
	LCCC – FK	Tube	SNJ54LS125AFK	SNJ54LS125AFK

† Package drawings, standard packing quantities, thermal data, symbolization, and PCB design guidelines are available at www.ti.com/sc/package.

logic diagram (each gate)

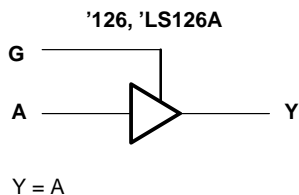
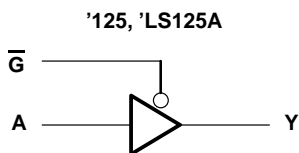

PACKAGING INFORMATION

Orderable Device	Status ⁽¹⁾	Package Type	Package Drawing	Pins	Package Qty	Eco Plan ⁽²⁾	Lead/Ball Finish	MSL Peak Temp ⁽³⁾
JM38510/32301B2A	ACTIVE	LCCC	FK	20	1	TBD	Call TI	Level-NC-NC-NC
JM38510/32301BCA	ACTIVE	CDIP	J	14	1	TBD	Call TI	Level-NC-NC-NC
JM38510/32301BDA	ACTIVE	CFP	W	14	1	TBD	Call TI	Level-NC-NC-NC
JM38510/32301SCA	ACTIVE	CDIP	J	14	1	TBD	Call TI	Level-NC-NC-NC
JM38510/32301SDA	ACTIVE	CFP	W	14	1	TBD	Call TI	Level-NC-NC-NC
SN54126J	OBSOLETE	CDIP	J	14		TBD	Call TI	Call TI
SN54LS125AJ	ACTIVE	CDIP	J	14	1	TBD	Call TI	Level-NC-NC-NC
SN74125N	OBSOLETE	PDIP	N	14		TBD	Call TI	Call TI
SN74125N3	OBSOLETE	PDIP	N	14		TBD	Call TI	Call TI
SN74126N	OBSOLETE	PDIP	N	14		TBD	Call TI	Call TI
SN74LS125AD	ACTIVE	SOIC	D	14	50	Pb-Free (RoHS)	CU NIPDAU	Level-2-260C-1 YEAR/ Level-1-235C-UNLIM
SN74LS125ADBR	ACTIVE	SSOP	DB	14	2000	Pb-Free (RoHS)	CU NIPDAU	Level-2-260C-1 YEAR/ Level-1-235C-UNLIM
SN74LS125ADBRE4	ACTIVE	SSOP	DB	14	2000	TBD	Call TI	Call TI
SN74LS125ADR	ACTIVE	SOIC	D	14	2500	Pb-Free (RoHS)	CU NIPDAU	Level-2-260C-1 YEAR/ Level-1-235C-UNLIM
SN74LS125AN	ACTIVE	PDIP	N	14	25	Pb-Free (RoHS)	CU NIPDAU	Level-NC-NC-NC
SN74LS125AN3	OBSOLETE	PDIP	N	14		TBD	Call TI	Call TI
SN74LS125ANSR	ACTIVE	SO	NS	14	2000	Pb-Free (RoHS)	CU NIPDAU	Level-2-260C-1 YEAR/ Level-1-235C-UNLIM
SN74LS125ANSRG4	ACTIVE	SO	NS	14	2000	Green (RoHS & no Sb/Br)	CU NIPDAU	Level-1-260C-UNLIM
SN74LS126AD	ACTIVE	SOIC	D	14	50	Pb-Free (RoHS)	CU NIPDAU	Level-2-260C-1 YEAR/ Level-1-235C-UNLIM
SN74LS126ADR	ACTIVE	SOIC	D	14	2500	Pb-Free (RoHS)	CU NIPDAU	Level-2-260C-1 YEAR/ Level-1-235C-UNLIM
SN74LS126AJ	OBSOLETE	CDIP	J	14		TBD	Call TI	Call TI
SN74LS126AN	ACTIVE	PDIP	N	14	25	Pb-Free (RoHS)	CU NIPDAU	Level-NC-NC-NC
SN74LS126ANSR	ACTIVE	SO	NS	14	2000	Pb-Free (RoHS)	CU NIPDAU	Level-2-260C-1 YEAR/ Level-1-235C-UNLIM
SNJ54126J	OBSOLETE	CDIP	J	14		TBD	Call TI	Call TI
SNJ54126W	OBSOLETE	CFP	W	14		TBD	Call TI	Call TI
SNJ54LS125AFK	ACTIVE	LCCC	FK	20	1	TBD	Call TI	Level-NC-NC-NC
SNJ54LS125AJ	ACTIVE	CDIP	J	14	1	TBD	Call TI	Level-NC-NC-NC
SNJ54LS125AW	ACTIVE	CFP	W	14	1	TBD	Call TI	Level-NC-NC-NC

⁽¹⁾ The marketing status values are defined as follows:

ACTIVE: Product device recommended for new designs.

LIFEBUY: TI has announced that the device will be discontinued, and a lifetime-buy period is in effect.

NRND: Not recommended for new designs. Device is in production to support existing customers, but TI does not recommend using this part in a new design.

PREVIEW: Device has been announced but is not in production. Samples may or may not be available.

OBSOLETE: TI has discontinued the production of the device.

⁽²⁾ Eco Plan - The planned eco-friendly classification: Pb-Free (RoHS) or Green (RoHS & no Sb/Br) - please check