

# SN54HC594, SN74HC594 8-BIT SHIFT REGISTERS WITH OUTPUT REGISTERS

SCLS040F – DECEMBER 1982 – REVISED OCTOBER 2003

- Wide Operating Voltage Range of 2 V to 6 V
- High-Current Outputs Can Drive Up To 15 LSTTL Loads
- Low Power Consumption, 80- $\mu$ A Max  $I_{CC}$
- Typical  $t_{pd} = 15$  ns
- $\pm 6$ -mA Output Drive at 5 V
- Low Input Current of 1  $\mu$ A Max
- 8-Bit Serial-In, Parallel-Out Shift Registers With Storage
- Independent Direct Overriding Clears on Shift and Storage Registers
- Independent Clocks for Both Shift and Storage Registers

SN54HC594 . . . J OR W PACKAGE  
SN74HC594 . . . D, DW, OR N PACKAGE  
(TOP VIEW)

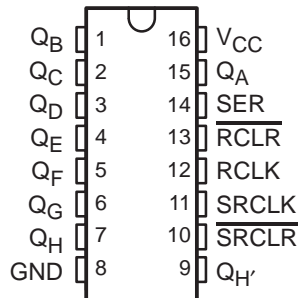

SN54HC594 . . . FK PACKAGE  
(TOP VIEW)

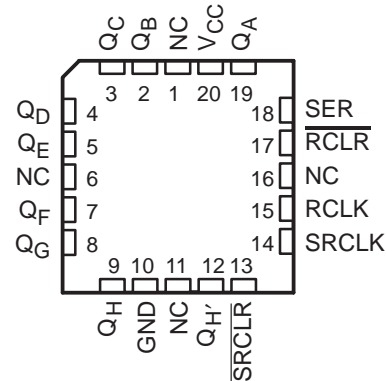

NC – No internal connection

## description/ordering information

The 'HC594 devices contain an 8-bit serial-in, parallel-out shift register that feeds an 8-bit D-type storage register. Separate clocks and direct overriding clear ( $\overline{RCLR}$ ,  $\overline{SRCLR}$ ) inputs are provided on both the shift and storage registers. A serial ( $Q_{H'}$ ) output is provided for cascading purposes.

Both the shift register (SRCLK) and storage register (RCLK) clocks are positive edge triggered. If both clocks are connected together, the shift register always is one count pulse ahead of the storage register.

The parallel ( $Q_A$ – $Q_H$ ) outputs have high-current capability.  $Q_{H'}$  is a standard output.

## ORDERING INFORMATION

TA	PACKAGE†		ORDERABLE PART NUMBER	TOP-SIDE MARKING
–40°C to 85°C	PDIP – N	Tube of 25	SN74HC594N	SN74HC594N
		Tube of 40	SN74HC594D	HC594
	SOIC – D	Reel of 2500	SN74HC594DR	
		Reel of 250	SN74HC594DT	
	SOIC – DW	Tube of 40	SN74HC594DW	HC594
Reel of 2000		SN74HC594DWR		
–55°C to 125°C	CDIP – J	Tube of 25	SNJ54HC594J	SNJ54HC594J
	CFP – W	Tube of 150	SNJ54HC594W	SNJ54HC594W
	LCCC – FK	Tube of 55	SNJ54HC594FK	SNJ54HC594FK

† Package drawings, standard packing quantities, thermal data, symbolization, and PCB design guidelines are available at [www.ti.com/sc/package](http://www.ti.com/sc/package).



Please be aware that an important notice concerning availability, standard warranty, and use in critical applications of Texas Instruments semiconductor products and disclaimers thereto appears at the end of this data sheet.

UNLESS OTHERWISE NOTED this document contains PRODUCTION DATA information current as of publication date. Products conform to specifications per the terms of Texas Instruments standard warranty. Production processing does not necessarily include testing of all parameters.

 **TEXAS  
INSTRUMENTS**

POST OFFICE BOX 655303 • DALLAS, TEXAS 75265

Copyright © 2003, Texas Instruments Incorporated

**SN54HC594, SN74HC594**  
**8-BIT SHIFT REGISTERS**  
**WITH OUTPUT REGISTERS**

SCLS040F – DECEMBER 1982 – REVISED OCTOBER 2003

**FUNCTION TABLE**

INPUTS					FUNCTION
SER	SRCLK	SRCLR	RCLK	RCLR	
X	X	L	X	X	Shift register is cleared.
L	↑	H	X	X	First stage of shift register goes low. Other stages store the data of previous stage, respectively.
H	↑	H	X	X	First stage of shift register goes high. Other stages store the data of previous stage, respectively.
L	↓	H	X	X	Shift register state is not changed.
X	X	X	X	L	Storage register is cleared.
X	X	X	↑	H	Shift register data is stored in the storage register.
X	X	X	↓	H	Storage register state is not changed.

# SN54HC594, SN74HC594 8-BIT SHIFT REGISTERS WITH OUTPUT REGISTERS

SCLS040F – DECEMBER 1982 – REVISED OCTOBER 2003

## logic diagram (positive logic)

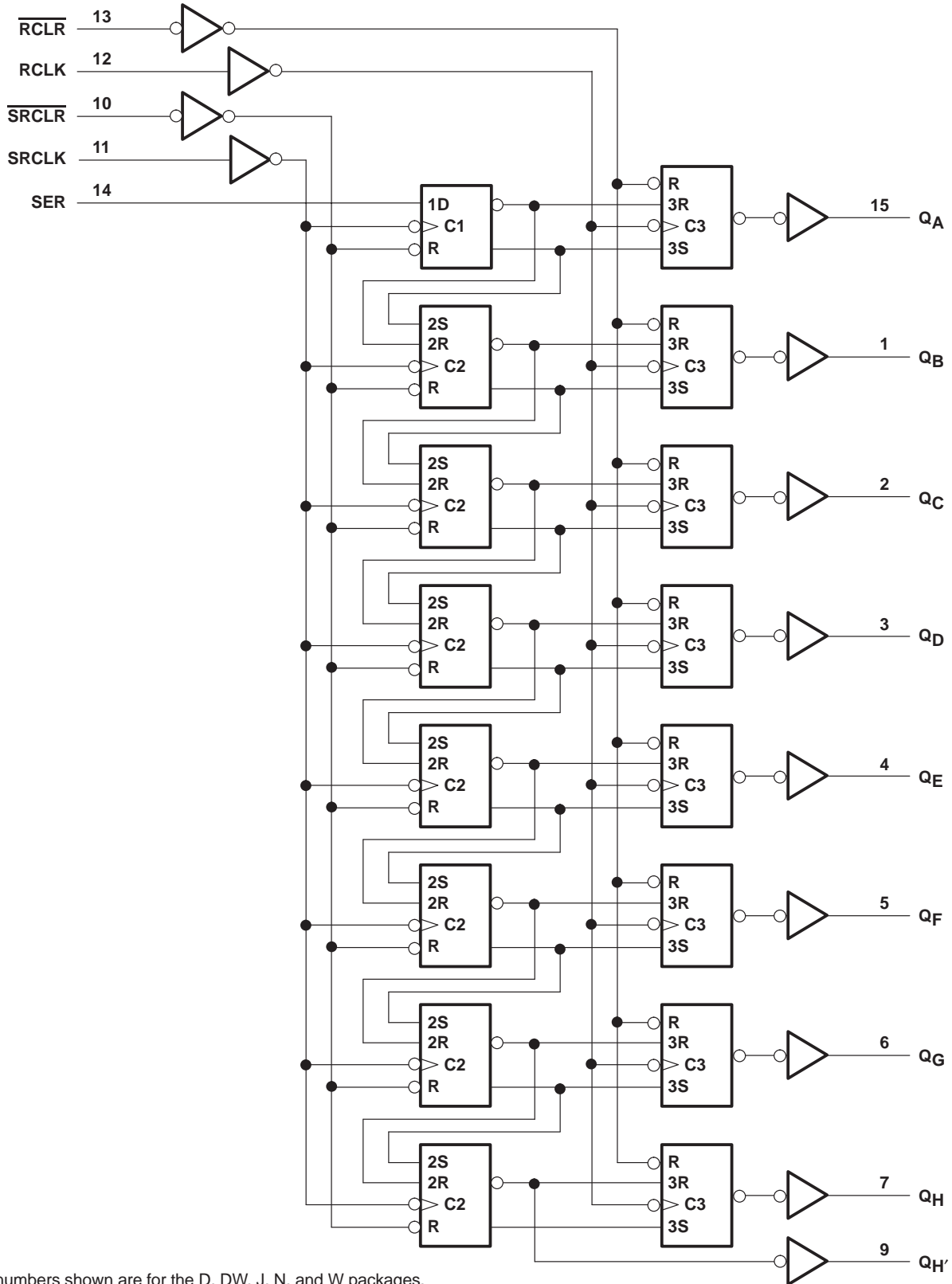

Pin numbers shown are for the D, DW, J, N, and W packages.



# SN54HC594, SN74HC594 8-BIT SHIFT REGISTERS WITH OUTPUT REGISTERS

SCLS040F – DECEMBER 1982 – REVISED OCTOBER 2003

## recommended operating conditions (see Note 3)

		SN54HC594			SN74HC594			UNIT
		MIN	NOM	MAX	MIN	NOM	MAX	
V <sub>CC</sub>	Supply voltage	2	5	6	2	5	6	V
V <sub>IH</sub>	High-level input voltage	V <sub>CC</sub> = 2 V		1.5	1.5		V	
		V <sub>CC</sub> = 4.5 V		3.15	3.15			
		V <sub>CC</sub> = 6 V		4.2	4.2			
V <sub>IL</sub>	Low-level input voltage	V <sub>CC</sub> = 2 V			0.5		V	
		V <sub>CC</sub> = 4.5 V			1.35			
		V <sub>CC</sub> = 6 V			1.8			
V <sub>I</sub>	Input voltage	0		V <sub>CC</sub>	0		V <sub>CC</sub>	V
V <sub>O</sub>	Output voltage	0		V <sub>CC</sub>	0		V <sub>CC</sub>	V
t <sub>t</sub>	Input transition (rise and fall) time	V <sub>CC</sub> = 2 V			1000		ns	
		V <sub>CC</sub> = 4.5 V			500			
		V <sub>CC</sub> = 6 V			400			
T <sub>A</sub>	Operating free-air temperature	-55		125	-40		85	°C

NOTE 3: All unused inputs of the device must be held at V<sub>CC</sub> or GND to ensure proper device operation. Refer to the TI application report, *Implications of Slow or Floating CMOS Inputs*, literature number SCBA004.

## electrical characteristics over recommended operating free-air temperature range (unless otherwise noted)

PARAMETER	TEST CONDITIONS		V <sub>CC</sub>	T <sub>A</sub> = 25°C			SN54HC594		SN74HC594		UNIT
				MIN	TYP	MAX	MIN	MAX	MIN	MAX	
V <sub>OH</sub>	V <sub>I</sub> = V <sub>IH</sub> or V <sub>IL</sub>	I <sub>OH</sub> = -20 μA	2 V	1.9	1.998		1.9		1.9	V	
			4.5 V	4.4	4.499		4.4		4.4		
			6 V	5.9	5.999		5.9		5.9		
		4.5 V	Q <sub>H</sub> ', I <sub>OH</sub> = -4 mA	3.98	4.3		3.7		3.84		
			Q <sub>A</sub> -Q <sub>H</sub> , I <sub>OH</sub> = -6 mA	3.98	4.3		3.7		3.84		
			Q <sub>H</sub> ', I <sub>OH</sub> = -5.2 mA	5.48	5.8		5.2		5.34		
6 V	Q <sub>A</sub> -Q <sub>H</sub> , I <sub>OH</sub> = -7.8 mA	5.48	5.8		5.2		5.34				
V <sub>OL</sub>	V <sub>I</sub> = V <sub>IH</sub> or V <sub>IL</sub>	I <sub>OL</sub> = 20 μA	2 V		0.002	0.1		0.1		0.1	V
			4.5 V		0.001	0.1		0.1		0.1	
			6 V		0.001	0.1		0.1		0.1	
		4.5 V	Q <sub>H</sub> ', I <sub>OL</sub> = 4 mA		0.17	0.26		0.4		0.33	
			Q <sub>A</sub> -Q <sub>H</sub> , I <sub>OL</sub> = 6 mA		0.17	0.26		0.4		0.33	
			Q <sub>H</sub> ', I <sub>OL</sub> = 5.2 mA		0.15	0.26		0.4		0.33	
6 V	Q <sub>A</sub> -Q <sub>H</sub> , I <sub>OL</sub> = 7.8 mA		0.15	0.26		0.4		0.33			
I <sub>I</sub>	V <sub>I</sub> = V <sub>CC</sub> or 0		6 V		±0.1	±100		±1000		±1000	nA
I <sub>OZ</sub>	V <sub>O</sub> = V <sub>CC</sub> or 0		6 V		±0.01	±0.5		±10		±5	μA
I <sub>CC</sub>	V <sub>I</sub> = V <sub>CC</sub> or 0, I <sub>O</sub> = 0		6 V			8		160		80	μA
C <sub>i</sub>			2 V to 6 V		3	10		10		10	pF

PRODUCT PREVIEW information concerns products in the formative or design phase of development. Characteristic data and other specifications are design goals. Texas Instruments reserves the right to change or discontinue these products without notice.



POST OFFICE BOX 655303 • DALLAS, TEXAS 75265

# SN54HC594, SN74HC594 8-BIT SHIFT REGISTERS WITH OUTPUT REGISTERS

SCLS040F – DECEMBER 1982 – REVISED OCTOBER 2003

timing requirements over recommended operating free-air temperature range (unless otherwise noted)

		V <sub>CC</sub>	T <sub>A</sub> = 25°C		SN54HC594		SN74HC594		UNIT
			MIN	MAX	MIN	MAX	MIN	MAX	
f <sub>clock</sub>	Clock frequency	2 V	5		3.3		4		MHz
		4.5 V	25		17		20		
		6 V	29		20		24		
t <sub>w</sub>	SRCLK or RCLK high or low	2 V	100		150		125		ns
		4.5 V	20		30		25		
		6 V	17		25		21		
	SRCLR or RCLR low	2 V	100		150		125		
		4.5 V	20		30		25		
		6 V	17		25		21		
t <sub>su</sub>	SER before SRCLK↑	2 V	90		135		110		ns
		4.5 V	18		27		22		
		6 V	15		23		19		
	SRCLK↑ before RCLK↑†	2 V	90		135		110		
		4.5 V	18		27		22		
		6 V	15		23		19		
	SRCLR low before RCLK↑	2 V	50		75		63		
		4.5 V	10		15		13		
		6 V	9		13		11		
	SRCLR high (inactive) before SRCLK↑	2 V	20		20		20		
		4.5 V	10		10		10		
		6 V	10		10		10		
	RCLR high (inactive) before SRCLK↑	2 V	5		5		5		
		4.5 V	5		5		5		
		6 V	5		5		5		
t <sub>h</sub>	Hold time, SER after SRCLK↑	2 V	5		5		5		ns
		4.5 V	5		5		5		
		6 V	5		5		5		

† This setup time ensures that the output register receives stable data from the shift-register outputs. The clocks may be tied together, in which case the output register is one clock pulse behind the shift register.

# SN54HC594, SN74HC594 8-BIT SHIFT REGISTERS WITH OUTPUT REGISTERS

SCLS040F – DECEMBER 1982 – REVISED OCTOBER 2003

switching characteristics over recommended operating free-air temperature range,  $C_L = 50$  pF (unless otherwise noted) (see Figure 1)

PARAMETER	FROM (INPUT)	TO (OUTPUT)	V <sub>CC</sub>	T <sub>A</sub> = 25°C			SN54HC594		SN74HC594		UNIT
				MIN	TYP	MAX	MIN	MAX	MIN	MAX	
f <sub>max</sub>			2 V	5	8		3.3		4	MHz	
			4.5 V	25	35		17		20		
			6 V	29	40		20		24		
t <sub>pd</sub>	SRCLK	Q <sub>H</sub> '	2 V		50	150		225		185	ns
			4.5 V		20	30		45		37	
			6 V		15	25		38		31	
	RCLK	Q <sub>A</sub> -Q <sub>H</sub>	2 V		50	150		225		185	
			4.5 V		20	30		45		37	
			6 V		15	25		38		31	
t <sub>PHL</sub>	SRCLK	Q <sub>H</sub> '	2 V		50	150		225		185	ns
			4.5 V		20	30		45		37	
			6 V		15	25		38		31	
	RCLK	Q <sub>A</sub> -Q <sub>H</sub>	2 V		50	125		185		155	
			4.5 V		20	25		37		31	
			6 V		15	21		31		26	
t <sub>t</sub>		Q <sub>H</sub> '	2 V		38	75		110		95	ns
			4.5 V		8	15		22		19	
			6 V		6	13		19		16	
		Q <sub>A</sub> -Q <sub>H</sub>	2 V		38	60		90		75	
			4.5 V		8	12		18		15	
			6 V		6	10		15		13	

switching characteristics over recommended operating free-air temperature range,  $C_L = 150$  pF (unless otherwise noted) (see Figure 1)

PARAMETER	FROM (INPUT)	TO (OUTPUT)	V <sub>CC</sub>	T <sub>A</sub> = 25°C			SN54HC594		SN74HC594		UNIT
				MIN	TYP	MAX	MIN	MAX	MIN	MAX	
t <sub>pd</sub>	RCLK	Q <sub>A</sub> -Q <sub>H</sub>	2 V		90	200		300		250	ns
			4.5 V		23	40		60		50	
			6 V		19	34		51		43	
t <sub>PHL</sub>	RCLK	Q <sub>A</sub> -Q <sub>H</sub>	2 V		90	200		300		250	ns
			4.5 V		23	40		60		50	
			6 V		19	34		51		43	
t <sub>t</sub>		Q <sub>A</sub> -Q <sub>H</sub>	2 V		45	210		315		265	ns
			4.5 V		17	42		63		53	
			6 V		13	36		53		45	

operating characteristics, T<sub>A</sub> = 25°C

PARAMETER	TEST CONDITIONS	TYP	UNIT
C <sub>pd</sub> Power dissipation capacitance	No load	395	pF

PRODUCT PREVIEW information concerns products in the formative or design phase of development. Characteristic data and other specifications are design goals. Texas Instruments reserves the right to change or discontinue these products without notice.



POST OFFICE BOX 655303 • DALLAS, TEXAS 75265

# SN54HC594, SN74HC594 8-BIT SHIFT REGISTERS WITH OUTPUT REGISTERS

SCLS040F – DECEMBER 1982 – REVISED OCTOBER 2003

## PARAMETER MEASUREMENT INFORMATION

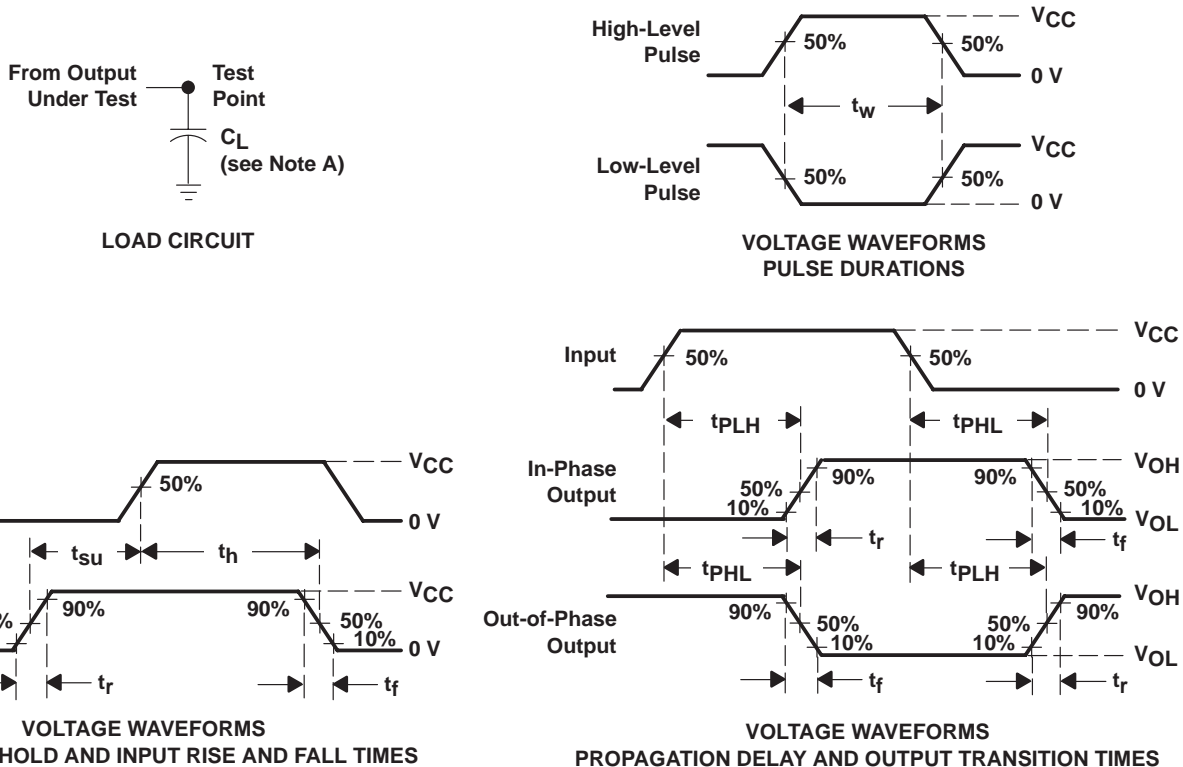

- NOTES:
- A.  $C_L$  includes probe and test-fixture capacitance.
  - B. Phase relationships between waveforms were chosen arbitrarily. All input pulses are supplied by generators having the following characteristics:  $PRR \leq 1$  MHz,  $Z_O = 50 \Omega$ ,  $t_r = 6$  ns,  $t_f = 6$  ns.
  - C. For clock inputs,  $f_{max}$  is measured when the input duty cycle is 50%.
  - D. The outputs are measured one at a time with one input transition per measurement.
  - E.  $t_{PLH}$  and  $t_{PHL}$  are the same as  $t_{pd}$ .
  - F.  $t_f$  and  $t_r$  are the same as  $t_t$ .

Figure 1. Load Circuit and Voltage Waveforms

N (R-PDIP-T\*\*)

PLASTIC DUAL-IN-LINE PACKAGE

16 PINS SHOWN



- NOTES:
- A. All linear dimensions are in inches (millimeters).
  - B. This drawing is subject to change without notice.
  - Falls within JEDEC MS-001, except 18 and 20 pin minimum body length (Dim A).
  - The 20 pin end lead shoulder width is a vendor option, either half or full width.

D (R-PDSO-G16)

PLASTIC SMALL-OUTLINE PACKAGE

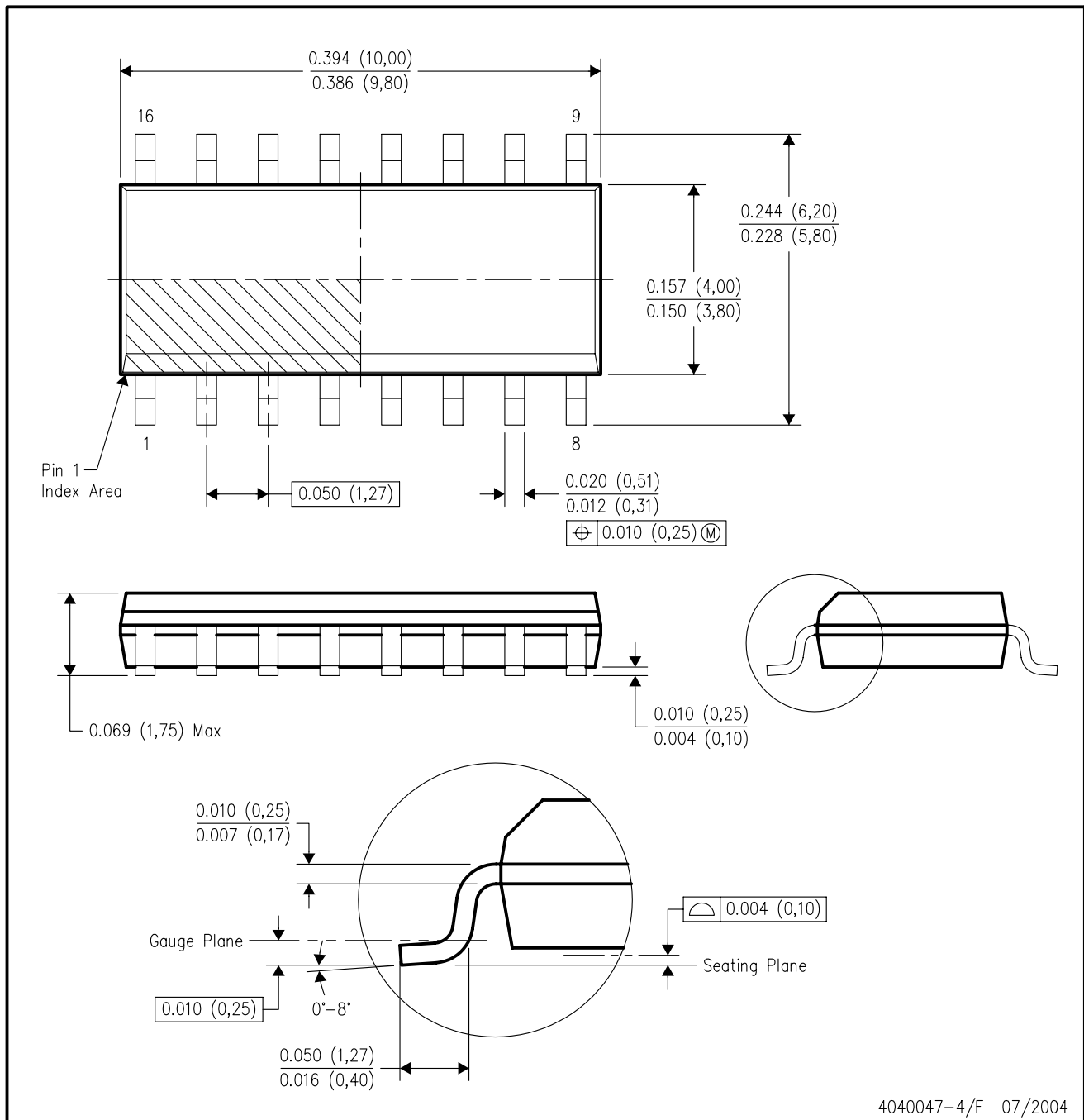

- NOTES:
- A. All linear dimensions are in inches (millimeters).
  - B. This drawing is subject to change without notice.
  - C. Body dimensions do not include mold flash or protrusion not to exceed 0.006 (0,15).
  - D. Falls within JEDEC MS-012 variation AC.

DW (R-PDSO-G16)

PLASTIC SMALL-OUTLINE PACKAGE

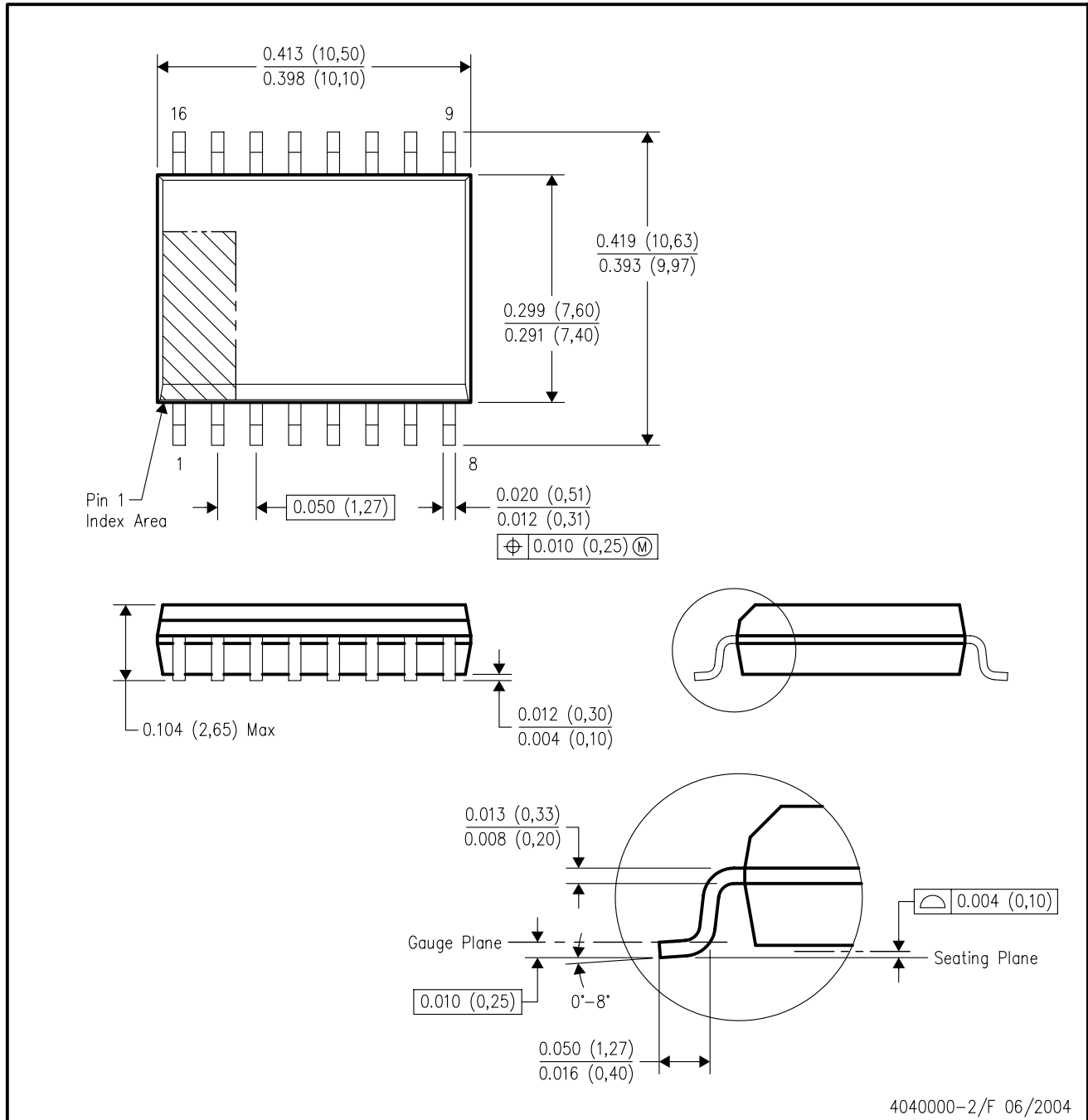

4040000-2/F 06/2004

- NOTES:
- A. All linear dimensions are in inches (millimeters).
  - B. This drawing is subject to change without notice.
  - C. Body dimensions do not include mold flash or protrusion not to exceed 0.006 (0,15).
  - D. Falls within JEDEC MS-013 variation AA.

## IMPORTANT NOTICE

Texas Instruments Incorporated and its subsidiaries (TI) reserve the right to make corrections, modifications, enhancements, improvements, and other changes to its products and services at any time and to discontinue any product or service without notice. Customers should obtain the latest relevant information before placing orders and should verify that such information is current and complete. All products are sold subject to TI's terms and conditions of sale supplied at the time of order acknowledgment.

TI warrants performance of its hardware products to the specifications applicable at the time of sale in accordance with TI's standard warranty. Testing and other quality control techniques are used to the extent TI deems necessary to support this warranty. Except where mandated by government requirements, testing of all parameters of each product is not necessarily performed.

TI assumes no liability for applications assistance or customer product design. Customers are responsible for their products and applications using TI components. To minimize the risks associated with customer products and applications, customers should provide adequate design and operating safeguards.

TI does not warrant or represent that any license, either express or implied, is granted under any TI patent right, copyright, mask work right, or other TI intellectual property right relating to any combination, machine, or process in which TI products or services are used. Information published by TI regarding third-party products or services does not constitute a license from TI to use such products or services or a warranty or endorsement thereof. Use of such information may require a license from a third party under the patents or other intellectual property of the third party, or a license from TI under the patents or other intellectual property of TI.

Reproduction of information in TI data books or data sheets is permissible only if reproduction is without alteration and is accompanied by all associated warranties, conditions, limitations, and notices. Reproduction of this information with alteration is an unfair and deceptive business practice. TI is not responsible or liable for such altered documentation.

Resale of TI products or services with statements different from or beyond the parameters stated by TI for that product or service voids all express and any implied warranties for the associated TI product or service and is an unfair and deceptive business practice. TI is not responsible or liable for any such statements.

Following are URLs where you can obtain information on other Texas Instruments products and application solutions:

<b>Products</b>		<b>Applications</b>	
Amplifiers	<a href="http://amplifier.ti.com">amplifier.ti.com</a>	Audio	<a href="http://www.ti.com/audio">www.ti.com/audio</a>
Data Converters	<a href="http://dataconverter.ti.com">dataconverter.ti.com</a>	Automotive	<a href="http://www.ti.com/automotive">www.ti.com/automotive</a>
DSP	<a href="http://dsp.ti.com">dsp.ti.com</a>	Broadband	<a href="http://www.ti.com/broadband">www.ti.com/broadband</a>
Interface	<a href="http://interface.ti.com">interface.ti.com</a>	Digital Control	<a href="http://www.ti.com/digitalcontrol">www.ti.com/digitalcontrol</a>
Logic	<a href="http://logic.ti.com">logic.ti.com</a>	Military	<a href="http://www.ti.com/military">www.ti.com/military</a>
Power Mgmt	<a href="http://power.ti.com">power.ti.com</a>	Optical Networking	<a href="http://www.ti.com/opticalnetwork">www.ti.com/opticalnetwork</a>
Microcontrollers	<a href="http://microcontroller.ti.com">microcontroller.ti.com</a>	Security	<a href="http://www.ti.com/security">www.ti.com/security</a>
		Telephony	<a href="http://www.ti.com/telephony">www.ti.com/telephony</a>
		Video & Imaging	<a href="http://www.ti.com/video">www.ti.com/video</a>
		Wireless	<a href="http://www.ti.com/wireless">www.ti.com/wireless</a>

Mailing Address: Texas Instruments  
Post Office Box 655303 Dallas, Texas 75265