

SN54HC574, SN74HC574 OCTAL EDGE-TRIGGERED D-TYPE FLIP-FLOPS WITH 3-STATE OUTPUTS

SCLS148F – DECEMBER 1982 – REVISED AUGUST 2003

- Wide Operating Voltage Range of 2 V to 6 V
- High-Current 3-State Noninverting Outputs Drive Bus Lines Directly or Up To 15 LSTTL Loads
- Low Power Consumption, 80- μ A Max I_{CC}
- Typical $t_{pd} = 22$ ns
- ± 6 -mA Output Drive at 5 V
- Low Input Current of 1 μ A Max
- Bus-Structured Pinout

description/ordering information

These octal edge-triggered D-type flip-flops feature 3-state outputs designed specifically for bus driving. They are particularly suitable for implementing buffer registers, I/O ports, bidirectional bus drivers, and working registers.

The eight flip-flops enter data on the low-to-high transition of the clock (CLK) input.

A buffered output-enable (\overline{OE}) input can be used to place the eight outputs in either a normal logic state (high or low logic levels) or the high-impedance state. In the high-impedance state, the outputs neither load nor drive the bus lines significantly. The high-impedance state and increased drive provide the capability to drive bus lines without interface or pullup components.

SN54HC574 . . . J OR W PACKAGE
SN74HC574 . . . DB, DW, N, NS, OR PW PACKAGE
(TOP VIEW)

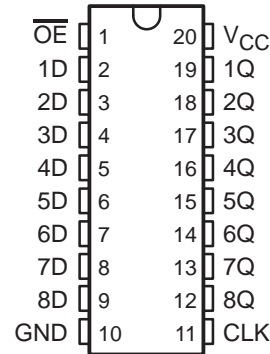

SN54HC574 . . . FK PACKAGE
(TOP VIEW)

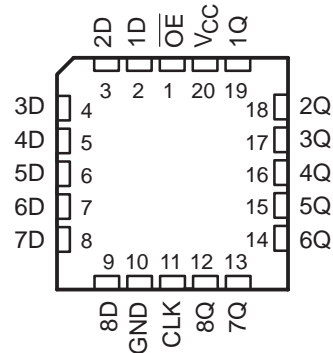

ORDERING INFORMATION

T_A	PACKAGE†		ORDERABLE PART NUMBER	TOP-SIDE MARKING
-40°C to 85°C	PDIP – N	Tube of 20	SN74HC574N	SN74HC574N
	SOIC – DW	Tube of 25	SN74HC574DW	HC574
		Reel of 2000	SN74HC574DWR	
	SSOP – DB	Reel of 2000	SN74HC574DBR	HC574
	SOP – NS	Reel of 2000	SN74HC574NSR	HC574
	TSSOP – PW	Tube of 70	SN74HC574PW	HC574
		Reel of 2000	SN74HC574PWR	
Reel of 250		SN74HC574PWT		
-55°C to 125°C	CDIP – J	Tube of 20	SNJ54HC574J	SNJ54HC574J
	CFP – W	Tube of 85	SNJ54HC574W	SNJ54HC574W
	LCCC – FK	Tube of 55	SNJ54HC574FK	SNJ54HC574FK

† Package drawings, standard packing quantities, thermal data, symbolization, and PCB design guidelines are available at www.ti.com/sc/package.



Please be aware that an important notice concerning availability, standard warranty, and use in critical applications of Texas Instruments semiconductor products and disclaimers thereto appears at the end of this data sheet.

PRODUCTION DATA information is current as of publication date. Products conform to specifications per the terms of Texas Instruments standard warranty. Production processing does not necessarily include testing of all parameters.

 **TEXAS
INSTRUMENTS**

POST OFFICE BOX 655303 • DALLAS, TEXAS 75265

Copyright © 2003, Texas Instruments Incorporated
On products compliant to MIL-PRF-38535, all parameters are tested unless otherwise noted. On all other products, production processing does not necessarily include testing of all parameters.

SN54HC574, SN74HC574 OCTAL EDGE-TRIGGERED D-TYPE FLIP-FLOPS WITH 3-STATE OUTPUTS

SCLS148F – DECEMBER 1982 – REVISED AUGUST 2003

description/ordering information (continued)

\overline{OE} does not affect the internal operations of the flip-flops. Old data can be retained or new data can be entered while the outputs are in the high-impedance state.

FUNCTION TABLE
(each flip-flop)

INPUTS			OUTPUT
\overline{OE}	CLK	D	Q
L	↑	H	H
L	↑	L	L
L	H or L	X	Q_0
H	X	X	Z

logic diagram (positive logic)

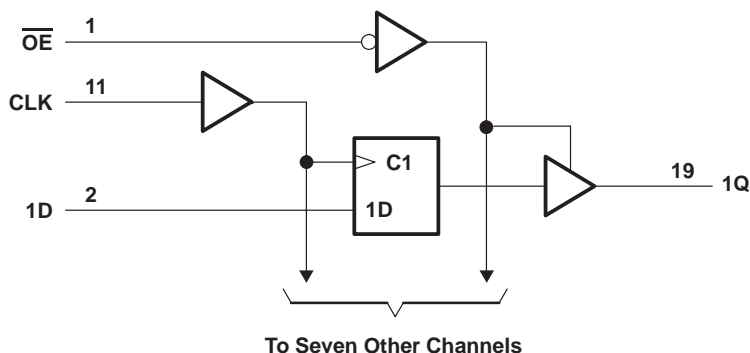

absolute maximum ratings over operating free-air temperature range (unless otherwise noted)†

Supply voltage range, V_{CC}	-0.5 V to 7 V
Input clamp current, I_{IK} ($V_I < 0$ or $V_I > V_{CC}$) (see Note 1)	± 20 mA
Output clamp current, I_{OK} ($V_O < 0$ or $V_O > V_{CC}$) (see Note 1)	± 20 mA
Continuous output current, I_O ($V_O = 0$ to V_{CC})	± 35 mA
Continuous current through V_{CC} or GND	± 70 mA
Package thermal impedance, θ_{JA} (see Note 2):	
DB package	70°C/W
DW package	58°C/W
N package	69°C/W
NS package	60°C/W
PW package	83°C/W
Storage temperature range, T_{stg}	-65°C to 150°C

† Stresses beyond those listed under “absolute maximum ratings” may cause permanent damage to the device. These are stress ratings only, and functional operation of the device at these or any other conditions beyond those indicated under “recommended operating conditions” is not implied. Exposure to absolute-maximum-rated conditions for extended periods may affect device reliability.

- NOTES: 1. The input and output voltage ratings may be exceeded if the input and output current ratings are observed.
2. The package thermal impedance is calculated in accordance with JESD 51-7.

SN54HC574, SN74HC574 OCTAL EDGE-TRIGGERED D-TYPE FLIP-FLOPS WITH 3-STATE OUTPUTS

SCLS148F – DECEMBER 1982 – REVISED AUGUST 2003

recommended operating conditions (see Note 3)

		SN54HC574			SN74HC574			UNIT
		MIN	NOM	MAX	MIN	NOM	MAX	
V _{CC}	Supply voltage	2	5	6	2	5	6	V
V _{IH}	High-level input voltage	V _{CC} = 2 V		1.5	1.5		V	
		V _{CC} = 4.5 V		3.15	3.15			
		V _{CC} = 6 V		4.2	4.2			
V _{IL}	Low-level input voltage	V _{CC} = 2 V			0.5		0.5	V
		V _{CC} = 4.5 V			1.35		1.35	
		V _{CC} = 6 V			1.8		1.8	
V _I	Input voltage	0		V _{CC}	0		V _{CC}	V
V _O	Output voltage	0		V _{CC}	0		V _{CC}	V
Δt/Δv	Input transition rise/fall time	V _{CC} = 2 V			1000		1000	ns
		V _{CC} = 4.5 V			500		500	
		V _{CC} = 6 V			400		400	
T _A	Operating free-air temperature	-55		125	-40		85	°C

NOTE 3: All unused inputs of the device must be held at V_{CC} or GND to ensure proper device operation. Refer to the TI application report, *Implications of Slow or Floating CMOS Inputs*, literature number SCBA004.

electrical characteristics over recommended operating free-air temperature range (unless otherwise noted)

PARAMETER	TEST CONDITIONS		V _{CC}	T _A = 25°C			SN54HC574		SN74HC574		UNIT
				MIN	TYP	MAX	MIN	MAX	MIN	MAX	
V _{OH}	V _I = V _{IH} or V _{IL}	I _{OH} = -20 μA	2 V	1.9	1.998		1.9		1.9	V	
			4.5 V	4.4	4.499		4.4		4.4		
			6 V	5.9	5.999		5.9		5.9		
		I _{OH} = -6 mA	4.5 V	3.98	4.3		3.7		3.84		
		I _{OH} = -7.8 mA	6 V	5.48	5.8		5.2		5.34		
V _{OL}	V _I = V _{IH} or V _{IL}	I _{OL} = 20 μA	2 V		0.002	0.1		0.1		0.1	V
			4.5 V		0.001	0.1		0.1		0.1	
			6 V		0.001	0.1		0.1		0.1	
		I _{OL} = 6 mA	4.5 V		0.17	0.26		0.4		0.33	
		I _{OL} = 7.8 mA	6 V		0.15	0.26		0.4		0.33	
I _I	V _I = V _{CC} or 0		6 V		±0.1	±100		±1000		±1000	nA
I _{OZ}	V _O = V _{CC} or 0		6 V		±0.01	±0.5		±10		±5	μA
I _{CC}	V _I = V _{CC} or 0, I _O = 0		6 V			8		160		80	μA
C _i			2 V to 6 V		3	10		10		10	pF



SN54HC574, SN74HC574
OCTAL EDGE-TRIGGERED D-TYPE FLIP-FLOPS
WITH 3-STATE OUTPUTS

SCLS148F – DECEMBER 1982 – REVISED AUGUST 2003

timing requirements over recommended operating free-air temperature range (unless otherwise noted)

	V _{CC}	T _A = 25°C		SN54HC574		SN74HC574		UNIT
		MIN	MAX	MIN	MAX	MIN	MAX	
f _{clock} Clock frequency	2 V	6		4		5		MHz
	4.5 V	30		20		24		
	6 V	38		24		28		
t _w Pulse duration, CLK high or low	2 V	80		120		100		ns
	4.5 V	16		24		20		
	6 V	14		20		17		
t _{su} Setup time, data before CLK↑	2 V	100		150		125		ns
	4.5 V	20		30		25		
	6 V	17		26		21		
t _h Hold time, data after CLK↑	2 V	5		5		5		ns
	4.5 V	5		5		5		
	6 V	5		5		5		

switching characteristics over recommended operating free-air temperature range, C_L = 50 pF (unless otherwise noted) (see Figure 1)

PARAMETER	FROM (INPUT)	TO (OUTPUT)	V _{CC}	T _A = 25°C			SN54HC574		SN74HC574		UNIT
				MIN	TYP	MAX	MIN	MAX	MIN	MAX	
f _{max}			2 V	6	11		4	5		MHz	
			4.5 V	30	36		20	24			
			6 V	36	40		24	28			
t _{pd}	CLK	Any Q	2 V		90	180		270		225	ns
			4.5 V		28	36		54		45	
			6 V		24	31		46		38	
t _{en}	\overline{OE}	Any Q	2 V		77	150		225		190	ns
			4.5 V		26	30		45		38	
			6 V		23	26		38		32	
t _{dis}	\overline{OE}	Any Q	2 V		52	150		225		190	ns
			4.5 V		24	30		45		38	
			6 V		22	26		38		32	
t _t		Any Q	2 V		28	60		90		75	ns
			4.5 V		8	12		18		15	
			6 V		6	10		15		13	



SN54HC574, SN74HC574
OCTAL EDGE-TRIGGERED D-TYPE FLIP-FLOPS
WITH 3-STATE OUTPUTS

SCLS148F – DECEMBER 1982 – REVISED AUGUST 2003

switching characteristics over recommended operating free-air temperature range, $C_L = 150$ pF (unless otherwise noted) (see Figure 1)

PARAMETER	FROM (INPUT)	TO (OUTPUT)	V_{CC}	$T_A = 25^\circ\text{C}$			SN54HC574		SN74HC574		UNIT
				MIN	TYP	MAX	MIN	MAX	MIN	MAX	
f_{max}			2 V	6					5		MHz
			4.5 V	30					24		
			6 V	36					28		
t_{pd}	CLK	Any Q	2 V	105	265	400		330		ns	
			4.5 V	36	53	80		66			
			6 V	31	46	68		57			
t_{en}	\overline{OE}	Any Q	2 V	95	235	355		295		ns	
			4.5 V	32	47	71		59			
			6 V	28	41	60		51			
t_t		Any Q	2 V	60	210	315		265		ns	
			4.5 V	17	42	63		53			
			6 V	14	36	53		45			

operating characteristics, $T_A = 25^\circ\text{C}$

PARAMETER	TEST CONDITIONS	TYP	UNIT
C_{pd} Power dissipation capacitance per flip-flop	No load	100	pF