

# SN54HC534, SN74HC534 OCTAL EDGE-TRIGGERED D-TYPE FLIP-FLOPS WITH 3-STATE OUTPUTS

SCLS311A – JANUARY 1996 – REVISED MAY 1997

- High-Current 3-State Inverting Outputs Can Drive up to 15 LSTTL Loads
- Package Options Include Plastic Small-Outline (DW) and Ceramic Flat (W) Packages, Ceramic Chip Carriers (FK), and Standard Plastic (N) and Ceramic (J) 300-mil DIPs

## description

These 8-bit flip-flops feature 3-state outputs designed specifically for driving highly capacitive or relatively low-impedance loads. They are particularly suitable for implementing buffer registers, I/O ports, bidirectional bus drivers, and working registers.

The eight flip-flops of the 'HC534 are edge-triggered D-type flip-flops. On the positive transition of the clock (CLK) input, the  $\bar{Q}$  outputs are set to the complement of the logic states that were set up at the data (D) inputs. The 'HC534 are functionally equivalent to the 'HC374, but the 'HC534 have inverted outputs.

An output-enable ( $\overline{OE}$ ) input places the eight outputs in either a normal logic state (high or low logic levels) or the high-impedance state. In the high-impedance state, the outputs neither load nor drive the bus lines significantly. The high-impedance state and increased drive provide the capability to drive bus lines without interface or pullup components.

$\overline{OE}$  does not affect the internal operations of the flip-flops. Old data can be retained or new data can be entered while the outputs are off.

The SN54HC534 is characterized for operation over the full military temperature range of  $-55^{\circ}\text{C}$  to  $125^{\circ}\text{C}$ . The SN74HC534 is characterized for operation from  $-40^{\circ}\text{C}$  to  $85^{\circ}\text{C}$ .

SN54HC534 . . . J OR W PACKAGE  
SN74HC534 . . . DW OR N PACKAGE  
(TOP VIEW)

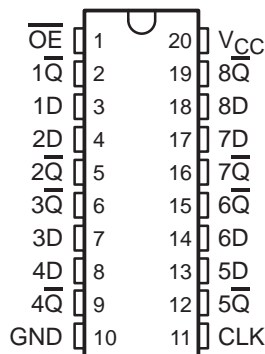

SN54HC534 . . . FK PACKAGE  
(TOP VIEW)

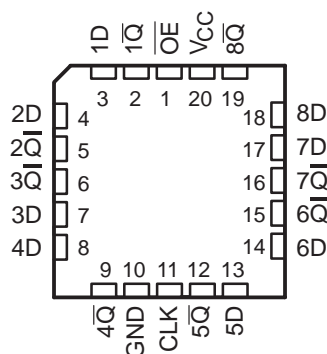

FUNCTION TABLE  
(each flip-flop)

INPUTS			OUTPUT
$\overline{OE}$	CLK	D	$\bar{Q}$
L	$\uparrow$	H	L
L	$\uparrow$	L	H
L	H or L	X	$\bar{Q}_0$
H	X	X	Z



Please be aware that an important notice concerning availability, standard warranty, and use in critical applications of Texas Instruments semiconductor products and disclaimers thereto appears at the end of this data sheet.

PRODUCTION DATA information is current as of publication date. Products conform to specifications per the terms of Texas Instruments standard warranty. Production processing does not necessarily include testing of all parameters.

 **TEXAS  
INSTRUMENTS**

POST OFFICE BOX 655303 • DALLAS, TEXAS 75265

Copyright © 1997, Texas Instruments Incorporated

# SN54HC534, SN74HC534 OCTAL EDGE-TRIGGERED D-TYPE FLIP-FLOPS WITH 3-STATE OUTPUTS

SCLS311A – JANUARY 1996 – REVISED MAY 1997

## logic symbol†

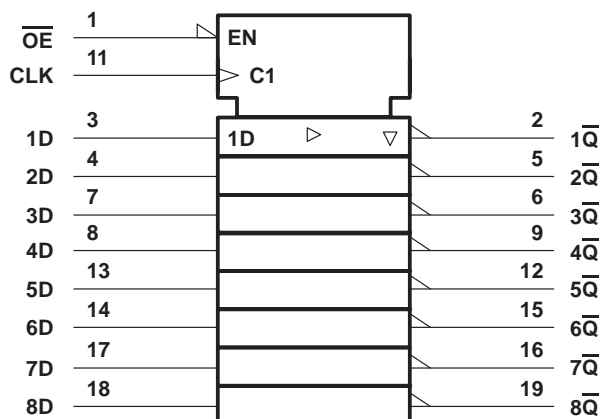

† This symbol is in accordance with ANSI/IEEE Std 91-1984 and IEC Publication 617-12.

## logic diagram (positive logic)

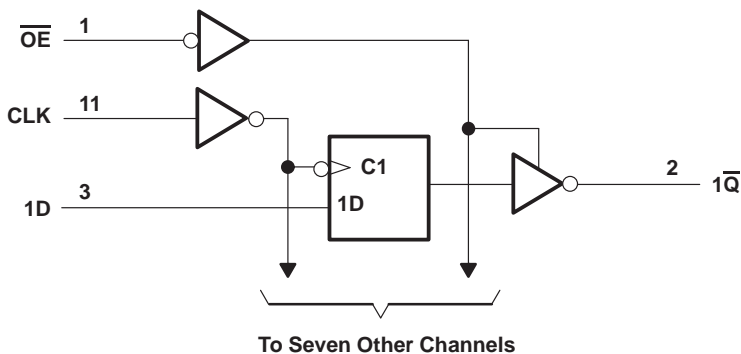

## absolute maximum ratings over operating free-air temperature range‡

Supply voltage range, $V_{CC}$ .....	-0.5 V to 7 V
Input clamp current, $I_{IK}$ ( $V_I < 0$ or $V_I > V_{CC}$ ) (see Note 1) .....	$\pm 20$ mA
Output clamp current, $I_{OK}$ ( $V_O < 0$ or $V_O > V_{CC}$ ) (see Note 1) .....	$\pm 20$ mA
Continuous output current, $I_O$ ( $V_O = 0$ to $V_{CC}$ ) .....	$\pm 35$ mA
Continuous current through $V_{CC}$ or GND .....	$\pm 70$ mA
Package thermal impedance, $\theta_{JA}$ (see Note 2): DW package .....	97°C/W
N package .....	67°C/W
Storage temperature range, $T_{stg}$ .....	-65°C to 150°C

‡ Stresses beyond those listed under “absolute maximum ratings” may cause permanent damage to the device. These are stress ratings only, and functional operation of the device at these or any other conditions beyond those indicated under “recommended operating conditions” is not implied. Exposure to absolute-maximum-rated conditions for extended periods may affect device reliability.

- NOTES: 1. The input and output voltage ratings may be exceeded if the input and output current ratings are observed.  
2. The package thermal impedance is calculated in accordance with JESD 51, except for through-hole packages, which use a trace length of zero.



# SN54HC534, SN74HC534 OCTAL EDGE-TRIGGERED D-TYPE FLIP-FLOPS WITH 3-STATE OUTPUTS

SCLS311A – JANUARY 1996 – REVISED MAY 1997

## recommended operating conditions

		SN54HC534			SN74HC534			UNIT
		MIN	NOM	MAX	MIN	NOM	MAX	
V <sub>CC</sub>	Supply voltage	2	5	6	2	5	6	V
V <sub>IH</sub>	High-level input voltage	V <sub>CC</sub> = 2 V		1.5	1.5		V	
		V <sub>CC</sub> = 4.5 V		3.15	3.15			
		V <sub>CC</sub> = 6 V		4.2	4.2			
V <sub>IL</sub>	Low-level input voltage	V <sub>CC</sub> = 2 V		0	0.5	0	0.5	V
		V <sub>CC</sub> = 4.5 V		0	1.35	0	1.35	
		V <sub>CC</sub> = 6 V		0	1.8	0	1.8	
V <sub>I</sub>	Input voltage	0		V <sub>CC</sub>	0		V <sub>CC</sub>	V
V <sub>O</sub>	Output voltage	0		V <sub>CC</sub>	0		V <sub>CC</sub>	V
t <sub>t</sub>	Input transition (rise and fall) time	V <sub>CC</sub> = 2 V		0	1000	0	1000	ns
		V <sub>CC</sub> = 4.5 V		0	500	0	500	
		V <sub>CC</sub> = 6 V		0	400	0	400	
T <sub>A</sub>	Operating free-air temperature	-55		125	-40		85	°C

## electrical characteristics over recommended operating free-air temperature range (unless otherwise noted)

PARAMETER	TEST CONDITIONS		V <sub>CC</sub>	T <sub>A</sub> = 25°C			SN54HC534		SN74HC534		UNIT
				MIN	TYP	MAX	MIN	MAX	MIN	MAX	
V <sub>OH</sub>	V <sub>I</sub> = V <sub>IH</sub> or V <sub>IL</sub>	I <sub>OH</sub> = -20 μA	2 V	1.9	1.998		1.9		1.9	V	
			4.5 V	4.4	4.499		4.4		4.4		
			6 V	5.9	5.999		5.9		5.9		
		I <sub>OH</sub> = -6 mA	4.5 V	3.98	4.3		3.7		3.84		
		I <sub>OH</sub> = -7.8 mA	6 V	5.48	5.8		5.2		5.34		
V <sub>OL</sub>	V <sub>I</sub> = V <sub>IH</sub> or V <sub>IL</sub>	I <sub>OL</sub> = 20 μA	2 V		0.002	0.1		0.1		V	
			4.5 V		0.001	0.1		0.1			0.1
			6 V		0.001	0.1		0.1			0.1
		I <sub>OL</sub> = 6 mA	4.5 V		0.17	0.26		0.4			0.33
		I <sub>OL</sub> = 7.8 mA	6 V		0.15	0.26		0.4			0.33
I <sub>I</sub>	V <sub>I</sub> = V <sub>CC</sub> or 0		6 V		±0.1	±100		±1000		±1000	nA
I <sub>OZ</sub>	V <sub>O</sub> = V <sub>CC</sub> or 0, V <sub>I</sub> = V <sub>IH</sub> or V <sub>IL</sub>		6 V		±0.01	±0.5		±10		±5	μA
I <sub>CC</sub>	V <sub>I</sub> = V <sub>CC</sub> or 0, I <sub>O</sub> = 0		6 V			8		160		80	μA
C <sub>i</sub>			2 V to 6 V		3	10		10		10	pF

**SN54HC534, SN74HC534**  
**OCTAL EDGE-TRIGGERED D-TYPE FLIP-FLOPS**  
**WITH 3-STATE OUTPUTS**

SCLS311A – JANUARY 1996 – REVISED MAY 1997

**timing requirements over recommended operating free-air temperature range (unless otherwise noted)**

	V <sub>CC</sub>	T <sub>A</sub> = 25°C		SN54HC534		SN74HC534		UNIT
		MIN	MAX	MIN	MAX	MIN	MAX	
f <sub>clock</sub> Clock frequency	2 V	0	6	0	4.2	0	5	MHz
	4.5 V	0	31	0	21	0	25	
	6 V	0	36	0	25	0	29	
t <sub>w</sub> Pulse duration, CLK high or low	2 V	80		120		100		ns
	4.5 V	16		24		20		
	6 V	14		20		17		
t <sub>su</sub> Setup time, data before CLK↑	2 V	100		150		125		ns
	4.5 V	20		30		25		
	6 V	17		26		21		
t <sub>h</sub> Hold time, data after CLK↑	2 V	5		5		5		ns
	4.5 V	5		5		5		
	6 V	5		5		5		

**switching characteristics over recommended operating free-air temperature range, C<sub>L</sub> = 50 pF (unless otherwise noted) (see Figure 1)**

PARAMETER	FROM (INPUT)	TO (OUTPUT)	V <sub>CC</sub>	T <sub>A</sub> = 25°C			SN54HC534		SN74HC534		UNIT
				MIN	TYP	MAX	MIN	MAX	MIN	MAX	
f <sub>max</sub>			2 V	6	11		4.2		5	MHz	
			4.5 V	31	36		21		25		
			6 V	36	40		25		29		
t <sub>pd</sub>	CLK	Any $\bar{Q}$	2 V		88	180		270		225	ns
			4.5 V		28	36		54		45	
			6 V		24	31		46		38	
t <sub>en</sub>	$\overline{OE}$	Any $\bar{Q}$	2 V		77	150		225		190	ns
			4.5 V		26	30		45		38	
			6 V		23	26		38		32	
t <sub>dis</sub>	$\overline{OE}$	Any $\bar{Q}$	2 V		51	150		225		190	ns
			4.5 V		25	30		45		38	
			6 V		23	26		38		32	
t <sub>t</sub>		Any $\bar{Q}$	2 V		28	60		90		75	ns
			4.5 V		8	12		18		15	
			6 V		6	10		15		13	



**SN54HC534, SN74HC534**  
**OCTAL EDGE-TRIGGERED D-TYPE FLIP-FLOPS**  
**WITH 3-STATE OUTPUTS**

SCLS311A – JANUARY 1996 – REVISED MAY 1997

switching characteristics over recommended operating free-air temperature range,  $C_L = 150$  pF (unless otherwise noted) (see Figure 1)

PARAMETER	FROM (INPUT)	TO (OUTPUT)	$V_{CC}$	$T_A = 25^\circ\text{C}$			SN54HC534		SN74HC534		UNIT
				MIN	TYP	MAX	MIN	MAX	MIN	MAX	
$t_{pd}$	CLK	Any $\bar{Q}$	2 V	105	230	345	290	ns			
			4.5 V	35	46	69	58				
			6 V	31	39	58	49				
$t_{en}$	$\overline{OE}$	Any $\bar{Q}$	2 V	95	200	300	250	ns			
			4.5 V	32	40	60	50				
			6 V	29	34	51	43				
$t_t$		Any $\bar{Q}$	2 V	60	210	315	265	ns			
			4.5 V	17	42	63	53				
			6 V	14	36	53	45				

operating characteristics,  $T_A = 25^\circ\text{C}$

PARAMETER	TEST CONDITIONS	TYP	UNIT
$C_{pd}$ Power dissipation capacitance per flip-flop	No load	100	pF

# SN54HC534, SN74HC534 OCTAL EDGE-TRIGGERED D-TYPE FLIP-FLOPS WITH 3-STATE OUTPUTS

SCLS311A – JANUARY 1996 – REVISED MAY 1997

## PARAMETER MEASUREMENT INFORMATION

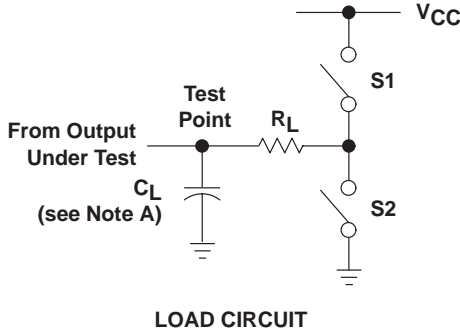

PARAMETER	$R_L$	$C_L$	S1	S2
$t_{en}$	1 k $\Omega$	50 pF or 150 pF	Open	Closed
			Closed	Open
$t_{dis}$	1 k $\Omega$	50 pF	Open	Closed
			Closed	Open
$t_{pd}$ or $t_t$	—	50 pF or 150 pF	Open	Open

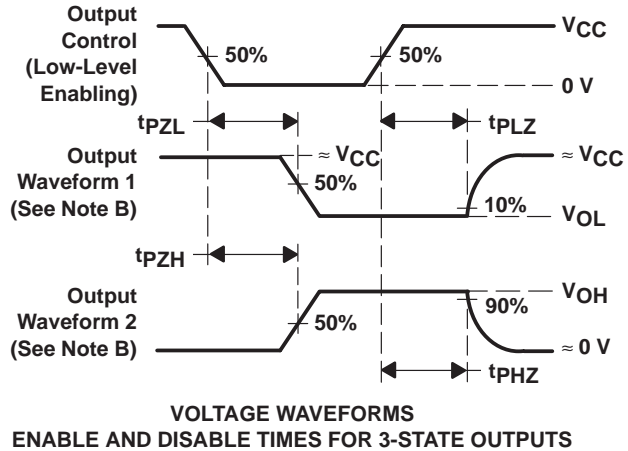
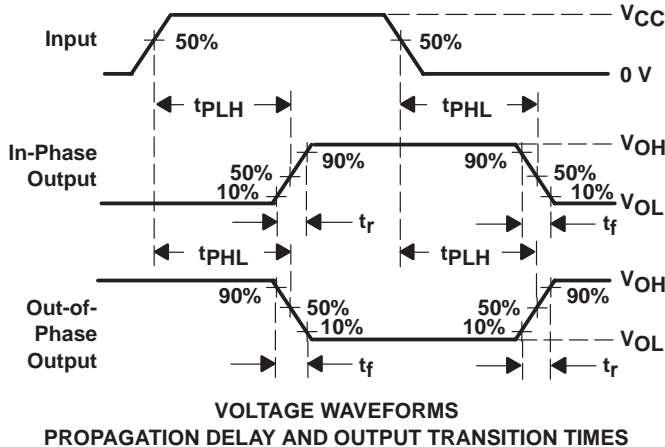
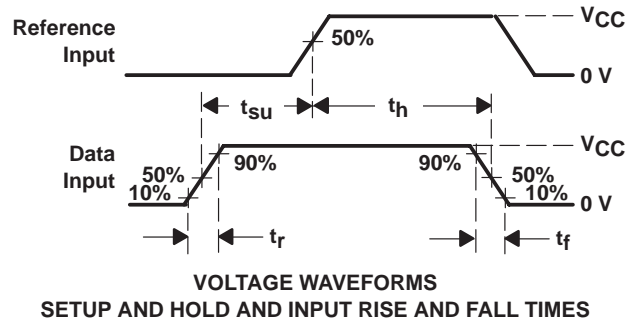
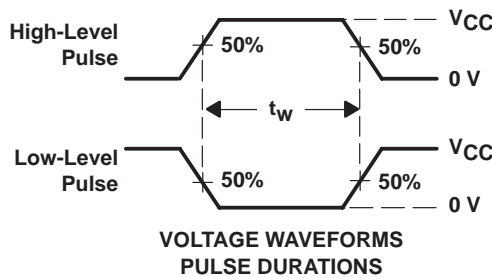

- NOTES: A.  $C_L$  includes probe and test-fixture capacitance.  
 B. Waveform 1 is for an output with internal conditions such that the output is low except when disabled by the output control. Waveform 2 is for an output with internal conditions such that the output is high except when disabled by the output control.  
 C. Phase relationships between waveforms were chosen arbitrarily. All input pulses are supplied by generators having the following characteristics:  $PRR \leq 1$  MHz,  $Z_O = 50 \Omega$ ,  $t_r = 6$  ns,  $t_f = 6$  ns.  
 D. For clock inputs,  $f_{max}$  is measured when the input duty cycle is 50%.  
 E. The outputs are measured one at a time with one input transition per measurement.  
 F.  $t_{PLZ}$  and  $t_{PHZ}$  are the same as  $t_{dis}$ .  
 G.  $t_{PZL}$  and  $t_{PZH}$  are the same as  $t_{en}$ .  
 H.  $t_{PLH}$  and  $t_{PHL}$  are the same as  $t_{pd}$ .

Figure 1. Load Circuit and Voltage Waveforms

## **IMPORTANT NOTICE**

Texas Instruments and its subsidiaries (TI) reserve the right to make changes to their products or to discontinue any product or service without notice, and advise customers to obtain the latest version of relevant information to verify, before placing orders, that information being relied on is current and complete. All products are sold subject to the terms and conditions of sale supplied at the time of order acknowledgement, including those pertaining to warranty, patent infringement, and limitation of liability.

TI warrants performance of its semiconductor products to the specifications applicable at the time of sale in accordance with TI's standard warranty. Testing and other quality control techniques are utilized to the extent TI deems necessary to support this warranty. Specific testing of all parameters of each device is not necessarily performed, except those mandated by government requirements.

**CERTAIN APPLICATIONS USING SEMICONDUCTOR PRODUCTS MAY INVOLVE POTENTIAL RISKS OF DEATH, PERSONAL INJURY, OR SEVERE PROPERTY OR ENVIRONMENTAL DAMAGE ("CRITICAL APPLICATIONS"). TI SEMICONDUCTOR PRODUCTS ARE NOT DESIGNED, AUTHORIZED, OR WARRANTED TO BE SUITABLE FOR USE IN LIFE-SUPPORT DEVICES OR SYSTEMS OR OTHER CRITICAL APPLICATIONS. INCLUSION OF TI PRODUCTS IN SUCH APPLICATIONS IS UNDERSTOOD TO BE FULLY AT THE CUSTOMER'S RISK.**

In order to minimize risks associated with the customer's applications, adequate design and operating safeguards must be provided by the customer to minimize inherent or procedural hazards.

TI assumes no liability for applications assistance or customer product design. TI does not warrant or represent that any license, either express or implied, is granted under any patent right, copyright, mask work right, or other intellectual property right of TI covering or relating to any combination, machine, or process in which such semiconductor products or services might be or are used. TI's publication of information regarding any third party's products or services does not constitute TI's approval, warranty or endorsement thereof.