

# SN54HC245, SN74HC245 OCTAL BUS TRANSCEIVERS WITH 3-STATE OUTPUTS

SCLS131D – DECEMBER 1982 – REVISED AUGUST 2003

- Wide Operating Voltage Range of 2 V to 6 V
- High-Current 3-State Outputs Drive Bus Lines Directly or Up To 15 LSTTL Loads
- Low Power Consumption, 80- $\mu$ A Max  $I_{CC}$
- Typical  $t_{pd} = 12$  ns
- $\pm 6$ -mA Output Drive at 5 V
- Low Input Current of 1  $\mu$ A Max

SN54HC245 . . . J OR W PACKAGE  
SN74HC245 . . . DB, DW, N, NS, OR PW PACKAGE  
(TOP VIEW)

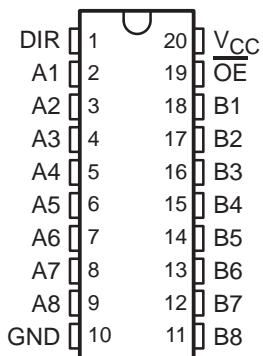

SN54HC245 . . . FK PACKAGE  
(TOP VIEW)

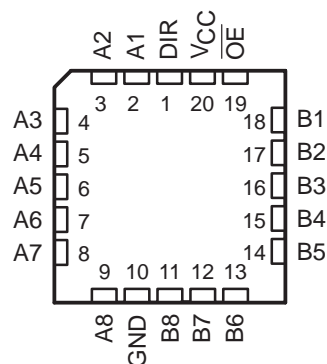

## description/ordering information

These octal bus transceivers are designed for asynchronous two-way communication between data buses. The control-function implementation minimizes external timing requirements.

The devices allow data transmission from the A bus to the B bus or from the B bus to the A bus, depending on the logic level at the direction-control (DIR) input. The output-enable ( $\overline{OE}$ ) input can be used to disable the device so that the buses are effectively isolated.

## ORDERING INFORMATION

$T_A$	PACKAGE†		ORDERABLE PART NUMBER	TOP-SIDE MARKING
-40°C to 85°C	PDIP – N	Tube of 20	SN74HC245N	SN74HC245N
	SOIC – DW	Tube of 25	SN74HC245DW	HC245
		Reel of 2000	SN74HC245DWR	
	SOP – NS	Reel of 2000	SN74HC245NSR	HC245
	SSOP – DB	Reel of 2000	SN74HC245DBR	HC245
	TSSOP – PW	Tube of 70	SN74HC245PW	HC245
Reel of 2000		SN74HC245PWR		
Reel of 250		SN74HC245PWT		
-55°C to 125°C	CDIP – J	Tube of 20	SNJ54HC245J	SNJ54HC245J
	CFP – W	Tube of 85	SNJ54HC245W	SNJ54HC245W
	LCCC – FK	Tube of 55	SNJ54HC245FK	SNJ54HC245FK

† Package drawings, standard packing quantities, thermal data, symbolization, and PCB design guidelines are available at [www.ti.com/sc/package](http://www.ti.com/sc/package).



Please be aware that an important notice concerning availability, standard warranty, and use in critical applications of Texas Instruments semiconductor products and disclaimers thereto appears at the end of this data sheet.

PRODUCTION DATA information is current as of publication date. Products conform to specifications per the terms of Texas Instruments standard warranty. Production processing does not necessarily include testing of all parameters.

 **TEXAS  
INSTRUMENTS**

POST OFFICE BOX 655303 • DALLAS, TEXAS 75265

Copyright © 2003, Texas Instruments Incorporated  
On products compliant to MIL-PRF-38535, all parameters are tested unless otherwise noted. On all other products, production processing does not necessarily include testing of all parameters.

# SN54HC245, SN74HC245 OCTAL BUS TRANSCEIVERS WITH 3-STATE OUTPUTS

SCLS131D – DECEMBER 1982 – REVISED AUGUST 2003

FUNCTION TABLE

INPUTS		OPERATION
$\overline{OE}$	DIR	
L	L	B data to A bus
L	H	A data to B bus
H	X	Isolation

## logic diagram (positive logic)

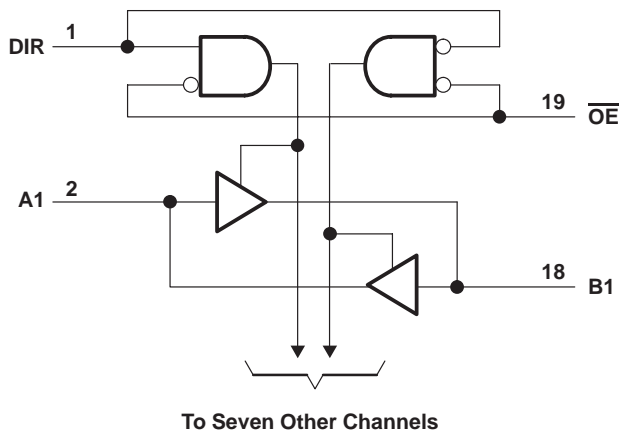

## absolute maximum ratings over operating free-air temperature range (unless otherwise noted)†

Supply voltage range, $V_{CC}$ .....	-0.5 V to 7 V
Input clamp current, $I_{IK}$ ( $V_I < 0$ or $V_I > V_{CC}$ ) (see Note 1) .....	$\pm 20$ mA
Output clamp current, $I_{OK}$ ( $V_O < 0$ or $V_O > V_{CC}$ ) (see Note 1) .....	$\pm 20$ mA
Continuous output current, $I_O$ ( $V_O = 0$ to $V_{CC}$ ) .....	$\pm 35$ mA
Continuous current through $V_{CC}$ or GND .....	$\pm 70$ mA
Package thermal impedance, $\theta_{JA}$ (see Note 2):	
DB package .....	70°C/W
DW package .....	58°C/W
N package .....	69°C/W
NS package .....	60°C/W
PW package .....	83°C/W
Storage temperature range, $T_{stg}$ .....	-65°C to 150°C

† Stresses beyond those listed under “absolute maximum ratings” may cause permanent damage to the device. These are stress ratings only, and functional operation of the device at these or any other conditions beyond those indicated under “recommended operating conditions” is not implied. Exposure to absolute-maximum-rated conditions for extended periods may affect device reliability.

- NOTES: 1. The input and output voltage ratings may be exceeded if the input and output current ratings are observed.  
2. The package thermal impedance is calculated in accordance with JESD 51-7.

# SN54HC245, SN74HC245 OCTAL BUS TRANSCEIVERS WITH 3-STATE OUTPUTS

SCLS131D – DECEMBER 1982 – REVISED AUGUST 2003

## recommended operating conditions (see Note 3)

		SN54HC245			SN74HC245			UNIT
		MIN	NOM	MAX	MIN	NOM	MAX	
V <sub>CC</sub>	Supply voltage	2	5	6	2	5	6	V
V <sub>IH</sub>	High-level input voltage	V <sub>CC</sub> = 2 V		1.5	1.5		V	
		V <sub>CC</sub> = 4.5 V		3.15	3.15			
		V <sub>CC</sub> = 6 V		4.2	4.2			
V <sub>IL</sub>	Low-level input voltage	V <sub>CC</sub> = 2 V			0.5		0.5	V
		V <sub>CC</sub> = 4.5 V			1.35		1.35	
		V <sub>CC</sub> = 6 V			1.8		1.8	
V <sub>I</sub>	Input voltage	0		V <sub>CC</sub>	0		V <sub>CC</sub>	V
V <sub>O</sub>	Output voltage	0		V <sub>CC</sub>	0		V <sub>CC</sub>	V
Δt/Δv	Input transition rise/fall time	V <sub>CC</sub> = 2 V			1000		1000	ns
		V <sub>CC</sub> = 4.5 V			500		500	
		V <sub>CC</sub> = 6 V			400		400	
T <sub>A</sub>	Operating free-air temperature	-55		125	-40		85	°C

NOTE 3: All unused inputs of the device must be held at V<sub>CC</sub> or GND to ensure proper device operation. Refer to the TI application report, *Implications of Slow or Floating CMOS Inputs*, literature number SCBA004.

## electrical characteristics over recommended operating free-air temperature range (unless otherwise noted)

PARAMETER	TEST CONDITIONS	V <sub>CC</sub>	T <sub>A</sub> = 25°C			SN54HC245		SN74HC245		UNIT	
			MIN	TYP	MAX	MIN	MAX	MIN	MAX		
V <sub>OH</sub>	V <sub>I</sub> = V <sub>IH</sub> or V <sub>IL</sub>	I <sub>OH</sub> = -20 μA	2 V	1.9	1.998		1.9		1.9	V	
			4.5 V	4.4	4.499		4.4		4.4		
			6 V	5.9	5.999		5.9		5.9		
		I <sub>OH</sub> = -6 mA	4.5 V	3.98	4.3		3.7		3.84		
			6 V	5.48	5.8		5.2		5.34		
V <sub>OL</sub>	V <sub>I</sub> = V <sub>IH</sub> or V <sub>IL</sub>	I <sub>OL</sub> = 20 μA	2 V		0.002	0.1		0.1		V	
			4.5 V		0.001	0.1		0.1			0.1
			6 V		0.001	0.1		0.1			0.1
		I <sub>OL</sub> = 6 mA	4.5 V		0.17	0.26		0.4			0.33
			6 V		0.15	0.26		0.4			0.33
I <sub>I</sub>	DIR or $\overline{\text{OE}}$	V <sub>I</sub> = V <sub>CC</sub> or 0	6 V		±0.1	±100		±1000		±1000	nA
I <sub>OZ</sub>	A or B	V <sub>O</sub> = V <sub>CC</sub> or 0	6 V		±0.01	±0.5		±10		±5	μA
I <sub>CC</sub>		V <sub>I</sub> = V <sub>CC</sub> or 0, I <sub>O</sub> = 0	6 V			8		160		80	μA
C <sub>i</sub>	DIR or $\overline{\text{OE}}$		2 V to 6 V		3	10		10		10	pF

**SN54HC245, SN74HC245**  
**OCTAL BUS TRANSCEIVERS**  
**WITH 3-STATE OUTPUTS**

SCLS131D – DECEMBER 1982 – REVISED AUGUST 2003

**switching characteristics over recommended operating free-air temperature range,  $C_L = 50$  pF (unless otherwise noted) (see Figure 1)**

PARAMETER	FROM (INPUT)	TO (OUTPUT)	V <sub>CC</sub>	T <sub>A</sub> = 25°C			SN54HC245		SN74HC245		UNIT
				MIN	TYP	MAX	MIN	MAX	MIN	MAX	
t <sub>pd</sub>	A or B	B or A	2 V		40	105		160		130	ns
			4.5 V		15	21		32		26	
			6 V		12	18		27		22	
t <sub>en</sub>	$\overline{OE}$	A or B	2 V		125	230		340		290	ns
			4.5 V		23	46		68		58	
			6 V		20	39		58		49	
t <sub>dis</sub>	$\overline{OE}$	A or B	2 V		74	200		300		250	ns
			4.5 V		25	40		60		50	
			6 V		21	34		51		43	
t <sub>t</sub>		A or B	2 V		20	60		90		75	ns
			4.5 V		8	12		18		15	
			6 V		6	10		15		13	

**switching characteristics over recommended operating free-air temperature range,  $C_L = 150$  pF (unless otherwise noted) (see Figure 1)**

PARAMETER	FROM (INPUT)	TO (OUTPUT)	V <sub>CC</sub>	T <sub>A</sub> = 25°C			SN54HC245		SN74HC245		UNIT
				MIN	TYP	MAX	MIN	MAX	MIN	MAX	
t <sub>pd</sub>	A or B	B or A	2 V		54	135		200		170	ns
			4.5 V		18	27		40		34	
			6 V		15	23		34		29	
t <sub>en</sub>	$\overline{OE}$	A or B	2 V		150	270		405		335	ns
			4.5 V		31	54		81		67	
			6 V		25	46		69		56	
t <sub>t</sub>		A or B	2 V		45	210		315		265	ns
			4.5 V		17	42		63		53	
			6 V		13	36		53		45	

**operating characteristics, T<sub>A</sub> = 25°C**

PARAMETER	TEST CONDITIONS	TYP	UNIT
C <sub>pd</sub> Power dissipation capacitance per transceiver	No load	40	pF



**PACKAGING INFORMATION**

Orderable Device	Status <sup>(1)</sup>	Package Type	Package Drawing	Pins	Package Qty	Eco Plan <sup>(2)</sup>	Lead/Ball Finish	MSL Peak Temp <sup>(3)</sup>
5962-8408501VRA	ACTIVE	CDIP	J	20	1	TBD	Call TI	Level-NC-NC-NC
5962-8408501VSA	ACTIVE	CFP	W	20	1	TBD	Call TI	Level-NC-NC-NC
84085012A	ACTIVE	LCCC	FK	20	1	TBD	Call TI	Level-NC-NC-NC
8408501RA	ACTIVE	CDIP	J	20	1	TBD	Call TI	Level-NC-NC-NC
8408501SA	ACTIVE	CFP	W	20	1	TBD	Call TI	Level-NC-NC-NC
JM38510/65503BRA	ACTIVE	CDIP	J	20	1	TBD	Call TI	Level-NC-NC-NC
JM38510/65503BSA	ACTIVE	CFP	W	20	1	TBD	Call TI	Level-NC-NC-NC
SN54HC245J	ACTIVE	CDIP	J	20	1	TBD	Call TI	Level-NC-NC-NC
SN74HC245DBLE	OBSOLETE	SSOP	DB	20		TBD	Call TI	Call TI
SN74HC245DBR	ACTIVE	SSOP	DB	20	2000	Pb-Free (RoHS)	CU NIPDAU	Level-2-260C-1 YEAR/ Level-1-235C-UNLIM
SN74HC245DBRE4	ACTIVE	SSOP	DB	20	2000	Pb-Free (RoHS)	CU NIPDAU	Level-2-260C-1 YEAR/ Level-1-235C-UNLIM
SN74HC245DW	ACTIVE	SOIC	DW	20	25	Pb-Free (RoHS)	CU NIPDAU	Level-2-250C-1 YEAR/ Level-1-235C-UNLIM
SN74HC245DWR	ACTIVE	SOIC	DW	20	2000	Pb-Free (RoHS)	CU NIPDAU	Level-2-250C-1 YEAR/ Level-1-235C-UNLIM
SN74HC245N	ACTIVE	PDIP	N	20	20	Pb-Free (RoHS)	CU NIPDAU	Level-NC-NC-NC
SN74HC245N3	OBSOLETE	PDIP	N	20		TBD	Call TI	Call TI
SN74HC245NSG4	ACTIVE	SO	NS	20	40	Green (RoHS & no Sb/Br)	CU NIPDAU	Level-1-260C-UNLIM
SN74HC245NSR	ACTIVE	SO	NS	20	2000	Pb-Free (RoHS)	CU NIPDAU	Level-2-260C-1 YEAR/ Level-1-235C-UNLIM
SN74HC245NSRG4	ACTIVE	SO	NS	20	2000	Green (RoHS & no Sb/Br)	CU NIPDAU	Level-1-260C-UNLIM
SN74HC245PW	ACTIVE	TSSOP	PW	20	70	Pb-Free (RoHS)	CU NIPDAU	Level-1-250C-UNLIM
SN74HC245PWE4	ACTIVE	TSSOP	PW	20	70	Pb-Free (RoHS)	CU NIPDAU	Level-1-250C-UNLIM
SN74HC245PWLE	OBSOLETE	TSSOP	PW	20		TBD	Call TI	Call TI
SN74HC245PWR	ACTIVE	TSSOP	PW	20	2000	Pb-Free (RoHS)	CU NIPDAU	Level-1-250C-UNLIM
SN74HC245PWRG4	ACTIVE	TSSOP	PW	20	2000	Green (RoHS & no Sb/Br)	CU NIPDAU	Level-1-260C-UNLIM
SN74HC245PWT	ACTIVE	TSSOP	PW	20	250	Pb-Free (RoHS)	CU NIPDAU	Level-1-250C-UNLIM
SN74HC245PWTE4	ACTIVE	TSSOP	PW	20	250	Pb-Free (RoHS)	CU NIPDAU	Level-1-250C-UNLIM
SNJ54HC245FK	ACTIVE	LCCC	FK	20	1	TBD	Call TI	Level-NC-NC-NC
SNJ54HC245J	ACTIVE	CDIP	J	20	1	TBD	Call TI	Level-NC-NC-NC
SNJ54HC245W	ACTIVE	CFP	W	20	1	TBD	Call TI	Level-NC-NC-NC

<sup>(1)</sup> The marketing status values are defined as follows:

**ACTIVE:** Product device recommended for new designs.

**LIFEBUY:** TI has announced that the device will be discontinued, and a lifetime-buy period is in effect.

**NRND:** Not recommended for new designs. Device is in production to support existing customers, but TI does not recommend using this part in a new design.