

# SN54HC163, SN74HC163 4-BIT SYNCHRONOUS BINARY COUNTERS

SCLS298D – JANUARY 1996 – REVISED – OCTOBER 2003

- Wide Operating Voltage Range of 2 V to 6 V
- Outputs Can Drive Up To 10 LSTTL Loads
- Low Power Consumption, 80- $\mu$ A Max  $I_{CC}$
- Typical  $t_{pd} = 14$  ns
- $\pm 4$ -mA Output Drive at 5 V
- Low Input Current of 1  $\mu$ A Max
- Internal Look-Ahead for Fast Counting
- Carry Output for n-Bit Cascading
- Synchronous Counting
- Synchronously Programmable

SN54HC163 . . . J OR W PACKAGE  
SN74HC163 . . . D, DB, N, NS, OR PW PACKAGE  
(TOP VIEW)

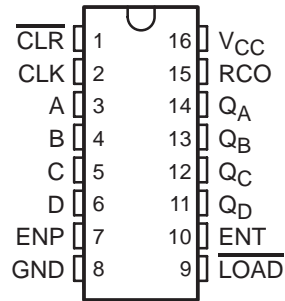

## description/ordering information

These synchronous, presettable counters feature an internal carry look-ahead for application in high-speed counting designs. The 'HC163 devices are 4-bit binary counters. Synchronous operation is provided by having all flip-flops clocked simultaneously so that the outputs change coincident with each other when instructed by the count-enable (ENP, ENT) inputs and internal gating. This mode of operation eliminates the output counting spikes normally associated with synchronous (ripple-clock) counters. A buffered clock (CLK) input triggers the four flip-flops on the rising (positive-going) edge of the clock waveform.

SN54HC163 . . . FK PACKAGE  
(TOP VIEW)

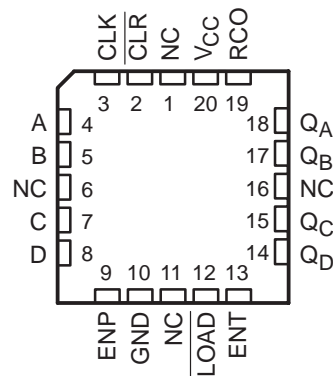

NC – No internal connection

## ORDERING INFORMATION

T <sub>A</sub>	PACKAGE†		ORDERABLE PART NUMBER	TOP-SIDE MARKING
-40°C to 85°C	PDIP – N	Tube of 25	SN74HC163N	SN74HC163N
	SOIC – D	Tube of 40	SN74HC163D	HC163
		Reel of 2500	SN74HC163DR	
		Reel of 250	SN74HC163DT	
	SOP – NS	Reel of 2000	SN74HC163NSR	HC163
	SSOP – DB	Reel of 2000	SN74HC163DBR	HC163
-55°C to 125°C	TSSOP – PW	Tube of 90	SN74HC163PW	HC163
		Reel of 2000	SN74HC163PWR	
		Reel of 250	SN74HC163PWT	
-55°C to 125°C	CDIP – J	Tube of 25	SNJ54HC163J	SNJ54HC163J
	CFP – W	Tube of 150	SNJ54HC163W	SNJ54HC163W
	LCCC – FK	Tube of 55	SNJ54HC163FK	SNJ54HC163FK

† Package drawings, standard packing quantities, thermal data, symbolization, and PCB design guidelines are available at [www.ti.com/sc/package](http://www.ti.com/sc/package).



Please be aware that an important notice concerning availability, standard warranty, and use in critical applications of Texas Instruments semiconductor products and disclaimers thereto appears at the end of this data sheet.

PRODUCTION DATA information is current as of publication date. Products conform to specifications per the terms of Texas Instruments standard warranty. Production processing does not necessarily include testing of all parameters.

 **TEXAS  
INSTRUMENTS**

POST OFFICE BOX 655303 • DALLAS, TEXAS 75265

Copyright © 2003, Texas Instruments Incorporated  
On products compliant to MIL-PRF-38535, all parameters are tested unless otherwise noted. On all other products, production processing does not necessarily include testing of all parameters.

# SN54HC163, SN74HC163

## 4-BIT SYNCHRONOUS BINARY COUNTERS

SCLS298D – JANUARY 1996 – REVISED – OCTOBER 2003

---

### description/ordering information (continued)

These counters are fully programmable; that is, they can be preset to any number between 0 and 9 or 15. As presetting is synchronous, setting up a low level at the load input disables the counter and causes the outputs to agree with the setup data after the next clock pulse, regardless of the levels of the enable inputs.

The clear function for the 'HC163 devices is synchronous. A low level at the clear ( $\overline{\text{CLR}}$ ) input sets all four of the flip-flop outputs low after the next low-to-high transition of CLK, regardless of the levels of the enable inputs. This synchronous clear allows the count length to be modified easily by decoding the Q outputs for the maximum count desired. The active-low output of the gate used for decoding is connected to  $\overline{\text{CLR}}$  to synchronously clear the counter to 0000 (LLLL).

The carry look-ahead circuitry provides for cascading counters for n-bit synchronous applications without additional gating. ENP, ENT, and a ripple-carry output (RCO) are instrumental in accomplishing this function. Both ENP and ENT must be high to count, and ENT is fed forward to enable RCO. Enabling RCO produces a high-level pulse while the count is maximum (9 or 15 with  $Q_A$  high). This high-level overflow ripple-carry pulse can be used to enable successive cascaded stages. Transitions at ENP or ENT are allowed, regardless of the level of CLK.

These counters feature a fully independent clock circuit. Changes at control inputs (ENP, ENT, or  $\overline{\text{LOAD}}$ ) that modify the operating mode have no effect on the contents of the counter until clocking occurs. The function of the counter (whether enabled, disabled, loading, or counting) is dictated solely by the conditions meeting the stable setup and hold times.



POST OFFICE BOX 655303 • DALLAS, TEXAS 75265

# SN54HC163, SN74HC163 4-BIT SYNCHRONOUS BINARY COUNTERS

SCLS298D – JANUARY 1996 – REVISED – OCTOBER 2003

## logic diagram (positive logic)

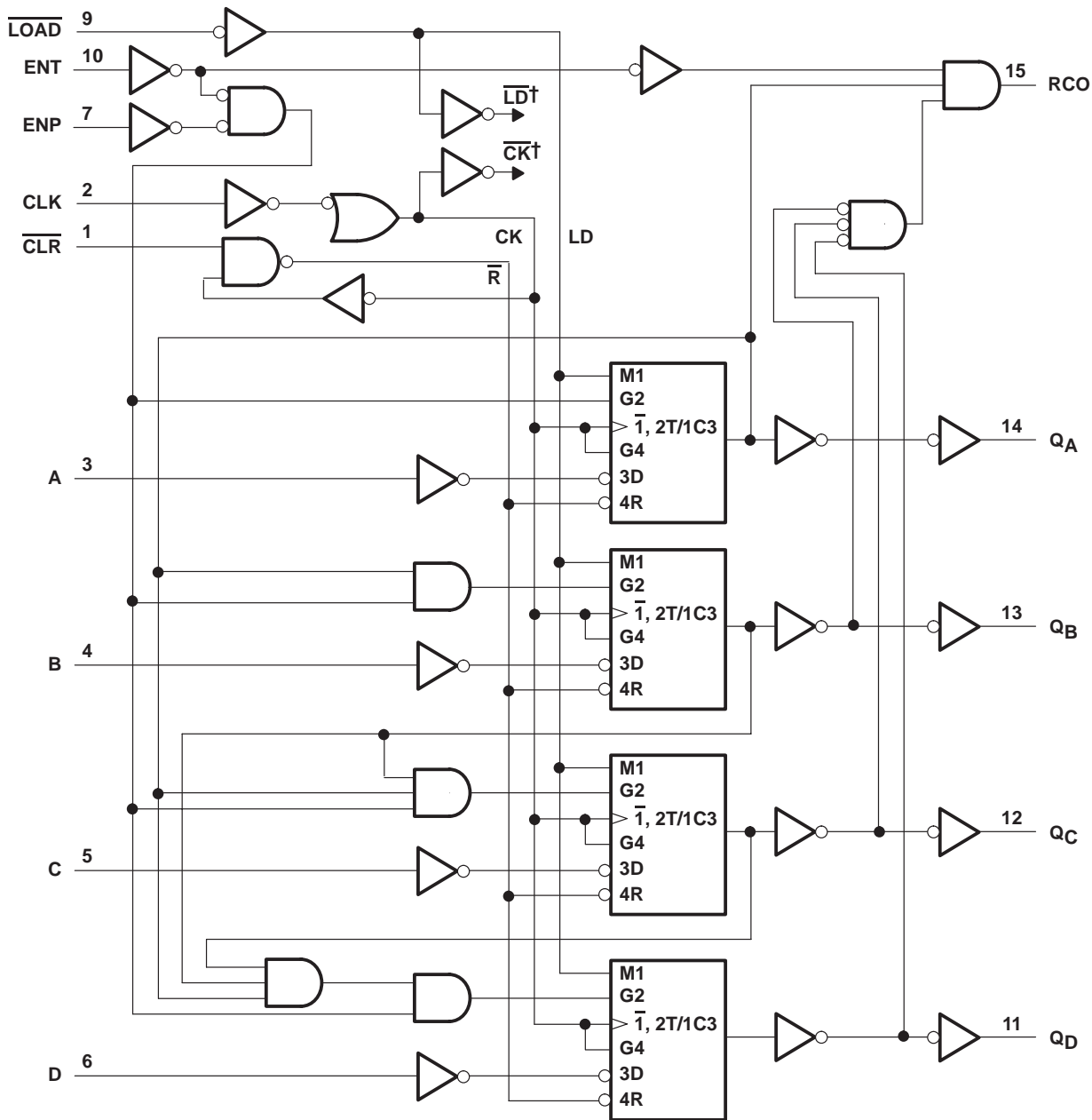

† For simplicity, routing of complementary signals  $\overline{\text{LD}}$  and  $\overline{\text{CK}}$  is not shown on this overall logic diagram. The uses of these signals are shown on the logic diagram of the D/T flip-flops.

Pin numbers shown are for the D, DB, J, N, NS, PW, and W packages.

# SN54HC163, SN74HC163 4-BIT SYNCHRONOUS BINARY COUNTERS

SCLS298D – JANUARY 1996 – REVISED – OCTOBER 2003

## logic symbol, each D/T flip-flop

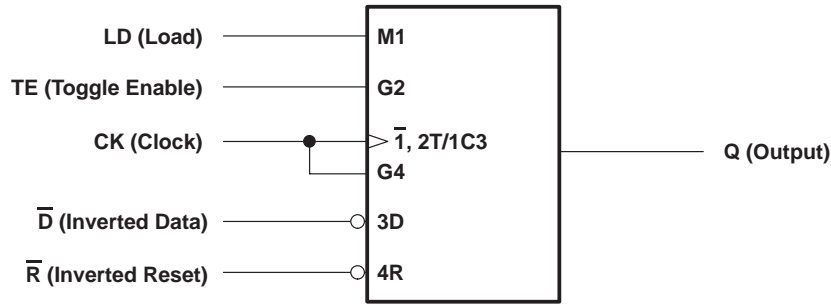

## logic diagram, each D/T flip-flop (positive logic)

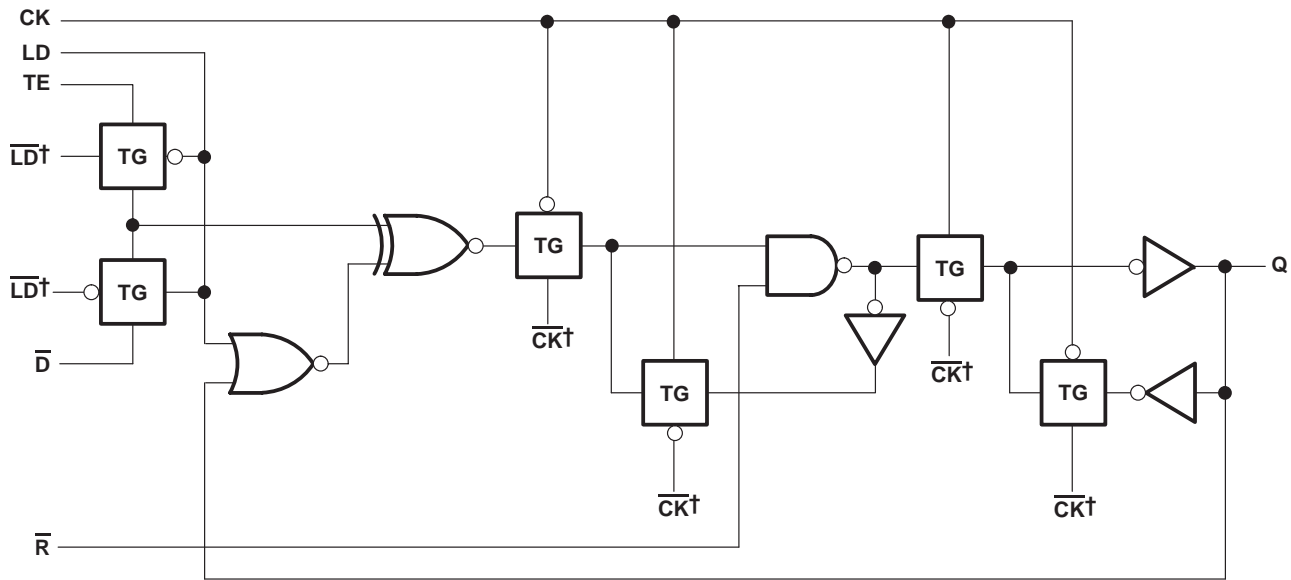

† The origins of  $\overline{LD}$  and  $\overline{CK}$  are shown in the logic diagram of the overall device.

typical clear, preset, count, and inhibit sequence

The following sequence is illustrated below:

1. Clear outputs to zero (synchronous)
2. Preset to binary 12
3. Count to 13, 14, 15, 0, 1, and 2
4. Inhibit

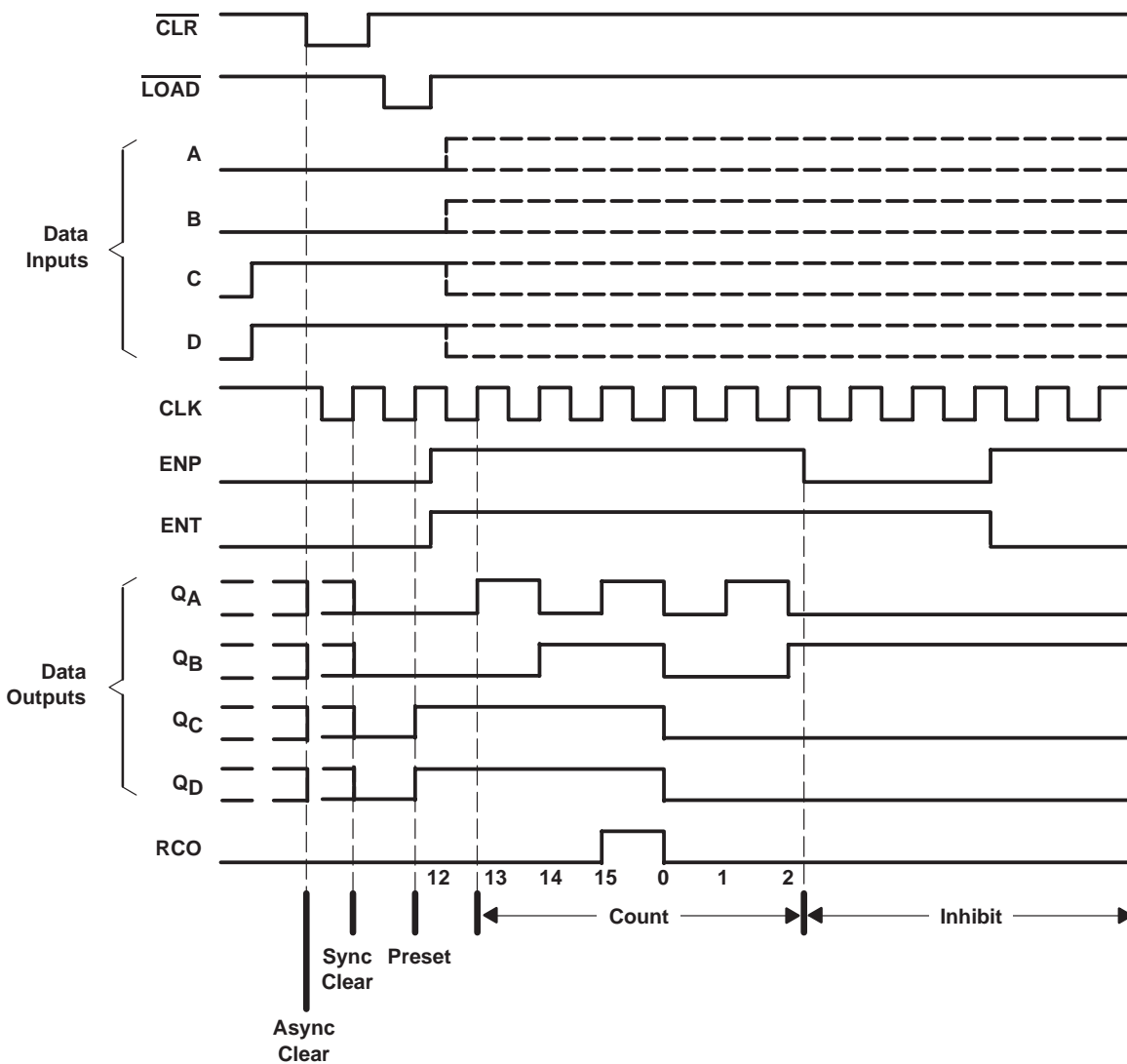

# SN54HC163, SN74HC163

## 4-BIT SYNCHRONOUS BINARY COUNTERS

SCLS298D – JANUARY 1996 – REVISED – OCTOBER 2003

### absolute maximum ratings over operating free-air temperature range (unless otherwise noted)†

Supply voltage range, $V_{CC}$ .....	-0.5 V to 7 V
Input clamp current, $I_{IK}$ ( $V_I < 0$ or $V_I > V_{CC}$ ) (see Note 1) .....	$\pm 20$ mA
Output clamp current, $I_{OK}$ ( $V_O < 0$ or $V_O > V_{CC}$ ) (see Note 1) .....	$\pm 20$ mA
Continuous output current, $I_O$ ( $V_O = 0$ to $V_{CC}$ ) .....	$\pm 25$ mA
Continuous current through $V_{CC}$ or GND .....	$\pm 50$ mA
Package thermal impedance, $\theta_{JA}$ (see Note 2): D package .....	73°C/W
DB package .....	82°C/W
N package .....	67°C/W
NS package .....	64°C/W
PW package .....	108°C/W
Storage temperature range, $T_{stg}$ .....	-65°C to 150°C

† Stresses beyond those listed under “absolute maximum ratings” may cause permanent damage to the device. These are stress ratings only, and functional operation of the device at these or any other conditions beyond those indicated under “recommended operating conditions” is not implied. Exposure to absolute-maximum-rated conditions for extended periods may affect device reliability.

- NOTES: 1. The input and output voltage ratings may be exceeded if the input and output current ratings are observed.  
 2. The package thermal impedance is calculated in accordance with JESD 51-7.

### recommended operating conditions (see Note 3)

		SN54HC163			SN74HC163			UNIT
		MIN	NOM	MAX	MIN	NOM	MAX	
$V_{CC}$	Supply voltage	2	5	6	2	5	6	V
$V_{IH}$	High-level input voltage	$V_{CC} = 2$ V		1.5	1.5		V	
		$V_{CC} = 4.5$ V		3.15	3.15			
		$V_{CC} = 6$ V		4.2	4.2			
$V_{IL}$	Low-level input voltage	$V_{CC} = 2$ V		0.5		0.5	V	
		$V_{CC} = 4.5$ V		1.35		1.35		
		$V_{CC} = 6$ V		1.8		1.8		
$V_I$	Input voltage	0	$V_{CC}$		0	$V_{CC}$		V
$V_O$	Output voltage	0	$V_{CC}$		0	$V_{CC}$		V
$\Delta t/\Delta v$ ‡	Input transition rise/fall time	$V_{CC} = 2$ V		1000		1000		ns
		$V_{CC} = 4.5$ V		500		500		
		$V_{CC} = 6$ V		400		400		
$T_A$	Operating free-air temperature	-55	125		-40	85		°C

NOTE 3: All unused inputs of the device must be held at  $V_{CC}$  or GND to ensure proper device operation. Refer to the TI application report, *Implications of Slow or Floating CMOS Inputs*, literature number SCBA004.

‡ If this device is used in the threshold region (from  $V_{ILmax} = 0.5$  V to  $V_{IHmin} = 1.5$  V), there is a potential to go into the wrong state from induced grounding, causing double clocking. Operating with the inputs at  $t_t = 1000$  ns and  $V_{CC} = 2$  V does not damage the device; however, functionally, the CLK inputs are not ensured while in the shift, count, or toggle operating modes.



# SN54HC163, SN74HC163 4-BIT SYNCHRONOUS BINARY COUNTERS

SCLS298D – JANUARY 1996 – REVISED – OCTOBER 2003

**electrical characteristics over recommended operating free-air temperature range (unless otherwise noted)**

PARAMETER	TEST CONDITIONS		V <sub>CC</sub>	T <sub>A</sub> = 25°C			SN54HC163		SN74HC163		UNIT	
				MIN	TYP	MAX	MIN	MAX	MIN	MAX		
V <sub>OH</sub>	V <sub>I</sub> = V <sub>IH</sub> or V <sub>IL</sub>	I <sub>OH</sub> = -20 μA	2 V	1.9	1.998		1.9		1.9	V		
			4.5 V	4.4	4.499		4.4		4.4			
			6 V	5.9	5.999		5.9		5.9			
		I <sub>OH</sub> = -4 mA	4.5 V	3.98	4.3		3.7		3.84			
		I <sub>OH</sub> = -5.2 mA	6 V	5.48	5.8		5.2		5.34			
V <sub>OL</sub>	V <sub>I</sub> = V <sub>IH</sub> or V <sub>IL</sub>	I <sub>OL</sub> = 20 μA	2 V		0.002	0.1		0.1		0.1	V	
			4.5 V		0.001	0.1		0.1		0.1		
			6 V		0.001	0.1		0.1		0.1		
		I <sub>OL</sub> = 4 mA	4.5 V		0.17	0.26		0.4		0.33		
		I <sub>OL</sub> = 5.2 mA	6 V		0.15	0.26		0.4		0.33		
I <sub>I</sub>	V <sub>I</sub> = V <sub>CC</sub> or 0		6 V		±0.1	±100		±1000		±1000	nA	
I <sub>CC</sub>	V <sub>I</sub> = V <sub>CC</sub> or 0, I <sub>O</sub> = 0		6 V				8		160		80	μA
C <sub>i</sub>			2 V to 6 V			3		10			10	pF

**timing requirements over recommended operating free-air temperature range (unless otherwise noted)**

			V <sub>CC</sub>	T <sub>A</sub> = 25°C		SN54HC163		SN74HC163		UNIT
				MIN	MAX	MIN	MAX	MIN	MAX	
f <sub>clock</sub>	Clock frequency		2 V		6		4.2		5	MHz
			4.5 V		31		21		25	
			6 V		36		25		29	
t <sub>w</sub>	Pulse duration	CLK high or low	2 V	80		120		100		ns
			4.5 V	16		24		20		
			6 V	14		20		17		
t <sub>su</sub>	Setup time before CLK↑	A, B, C, or D	2 V	150		225		190		ns
			4.5 V	30		45		38		
			6 V	26		38		32		
		LOAD low	2 V	135		205		170		
			4.5 V	27		41		34		
			6 V	23		35		29		
		ENP, ENT	2 V	170		255		215		
			4.5 V	34		51		43		
			6 V	29		43		37		
		CLR low	2 V	160		240		200		
			4.5 V	32		48		40		
			6 V	27		41		34		
		CLR inactive	2 V	160		240		200		
			4.5 V	32		48		40		
			6 V	27		41		34		
t <sub>h</sub>	Hold time, all synchronous inputs after CLK↑		2 V	0		0		0	ns	
			4.5 V	0		0		0		
			6 V	0		0		0		



# SN54HC163, SN74HC163

## 4-BIT SYNCHRONOUS BINARY COUNTERS

SCLS298D – JANUARY 1996 – REVISED – OCTOBER 2003

switching characteristics over recommended operating free-air temperature range,  $C_L = 50$  pF (unless otherwise noted) (see Figure 1)

PARAMETER	FROM (INPUT)	TO (OUTPUT)	$V_{CC}$	$T_A = 25^\circ\text{C}$			SN54HC163		SN74HC163		UNIT
				MIN	TYP	MAX	MIN	MAX	MIN	MAX	
$f_{max}$			2 V	6	14		4.2		5	MHz	
			4.5 V	31	40		21		25		
			6 V	36	44		25		29		
$t_{pd}$	CLK	RCO	2 V		83	215		325		270	ns
			4.5 V		24	43		65		54	
			6 V		20	37		55		46	
		Any Q	2 V		80	205		310		255	
			4.5 V		25	41		62		51	
			6 V		21	35		53		43	
	ENT	RCO	2 V		62	195		295		245	
			4.5 V		17	39		59		49	
			6 V		14	33		50		42	
$t_t$		Any	2 V		38	75		110		95	ns
			4.5 V		8	15		22		19	
			6 V		6	13		19		16	

operating characteristics,  $T_A = 25^\circ\text{C}$

PARAMETER		TEST CONDITIONS	TYP	UNIT
$C_{pd}$	Power dissipation capacitance	No load	60	pF

PARAMETER MEASUREMENT INFORMATION

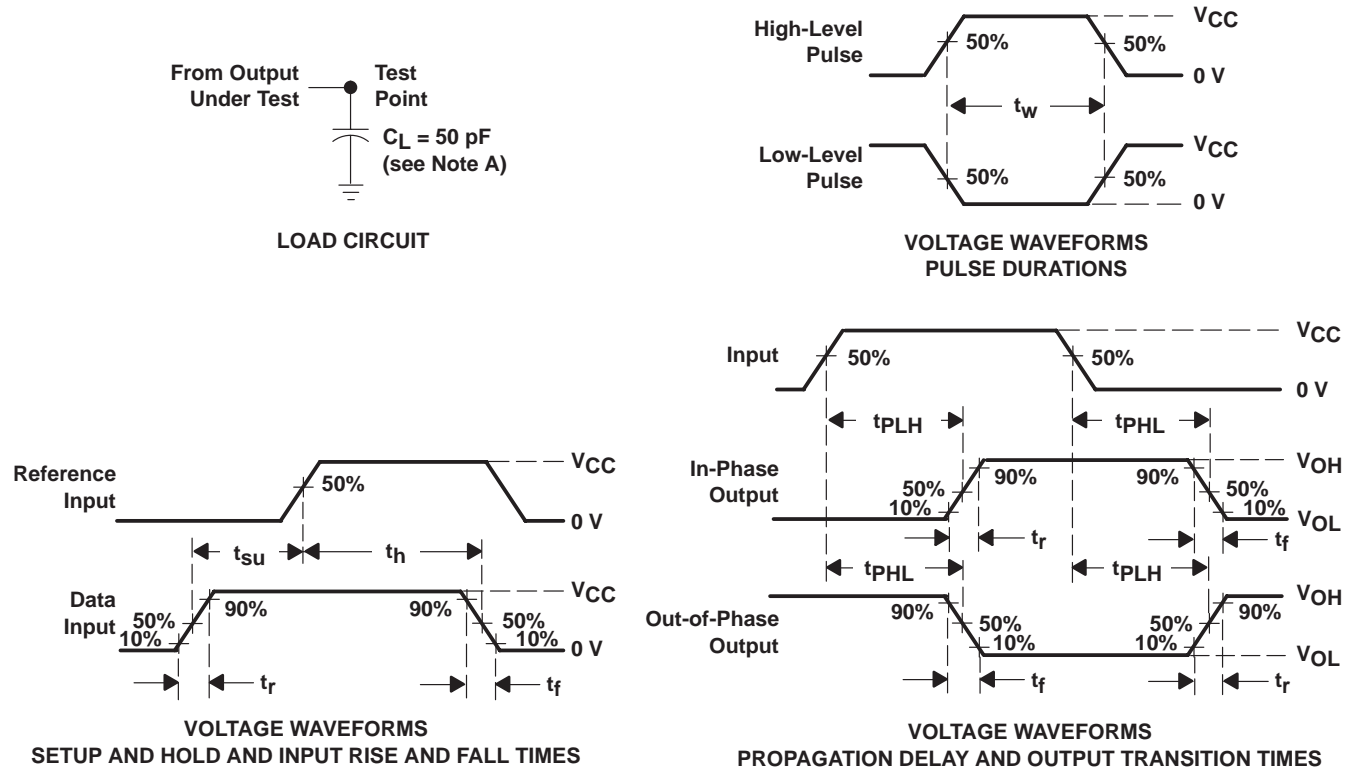

- NOTES:
- A.  $C_L$  includes probe and test-fixture capacitance.
  - B. Phase relationships between waveforms were chosen arbitrarily. All input pulses are supplied by generators having the following characteristics:  $PRR \leq 1 \text{ MHz}$ ,  $Z_O = 50 \Omega$ ,  $t_r = 6 \text{ ns}$ ,  $t_f = 6 \text{ ns}$ .
  - C. For clock inputs,  $f_{max}$  is measured when the input duty cycle is 50%.
  - D. The outputs are measured one at a time with one input transition per measurement.
  - E.  $t_{PLH}$  and  $t_{PHL}$  are the same as  $t_{pd}$ .

Figure 1. Load Circuit and Voltage Waveforms

# SN54HC163, SN74HC163 4-BIT SYNCHRONOUS BINARY COUNTERS

SCLS298D – JANUARY 1996 – REVISED – OCTOBER 2003

---

## APPLICATION INFORMATION

### n-bit synchronous counters

This application demonstrates how the look-ahead carry circuit can be used to implement a high-speed n-bit counter. The 'HC163 devices count in binary. Virtually any count mode (modulo-N,  $N_1$ -to- $N_2$ ,  $N_1$ -to-maximum) can be used with this fast look-ahead circuit.

The application circuit shown in Figure 2 is not valid for clock frequencies above 18 MHz (at 25°C and 4.5-V  $V_{CC}$ ). The reason for this is that there is a glitch that is produced on the second stage's RCO and every succeeding stage's RCO. This glitch is common to all HC vendors that Texas Instruments has evaluated, in addition to the bipolar equivalents (LS, ALS, AS).



POST OFFICE BOX 655303 • DALLAS, TEXAS 75265

# SN54HC163, SN74HC163 4-BIT SYNCHRONOUS BINARY COUNTERS

SCLS298D – JANUARY 1996 – REVISED – OCTOBER 2003

## APPLICATION INFORMATION

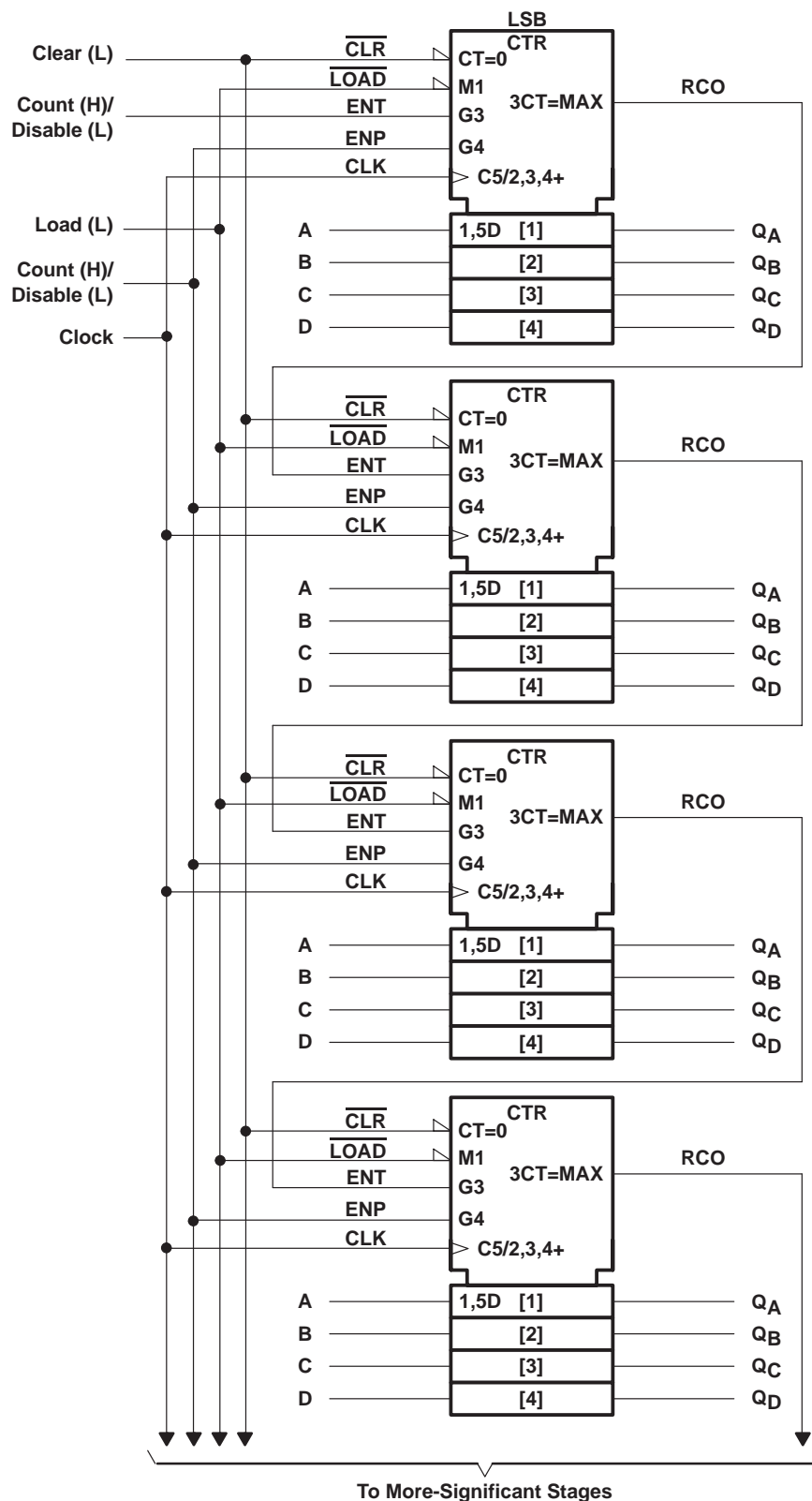

Figure 2



# SN54HC163, SN74HC163

## 4-BIT SYNCHRONOUS BINARY COUNTERS

SCLS298D – JANUARY 1996 – REVISED – OCTOBER 2003

### APPLICATION INFORMATION

#### n-bit synchronous counters (continued)

The glitch on RCO is caused because the propagation delay of the rising edge of  $Q_A$  of the second stage is shorter than the propagation delay of the falling edge of ENT. RCO is the product of ENT,  $Q_A$ ,  $Q_B$ ,  $Q_C$ , and  $Q_D$  ( $ENT \times Q_A \times Q_B \times Q_C \times Q_D$ ). The resulting glitch is about 7–12 ns in duration. Figure 3 shows the condition in which the glitch occurs. For simplicity, only two stages are being considered, but the results can be applied to other stages.  $Q_B$ ,  $Q_C$ , and  $Q_D$  of the first and second stage are at logic one, and  $Q_A$  of both stages are at logic zero (1110 1110) after the first clock pulse. On the rising edge of the second clock pulse,  $Q_A$  and RCO of the first stage go high. On the rising edge of the third clock pulse,  $Q_A$  and RCO of the first stage return to a low level, and  $Q_A$  of the second stage goes to a high level. At this time, the glitch on RCO of the second stage appears because of the race condition inside the chip.

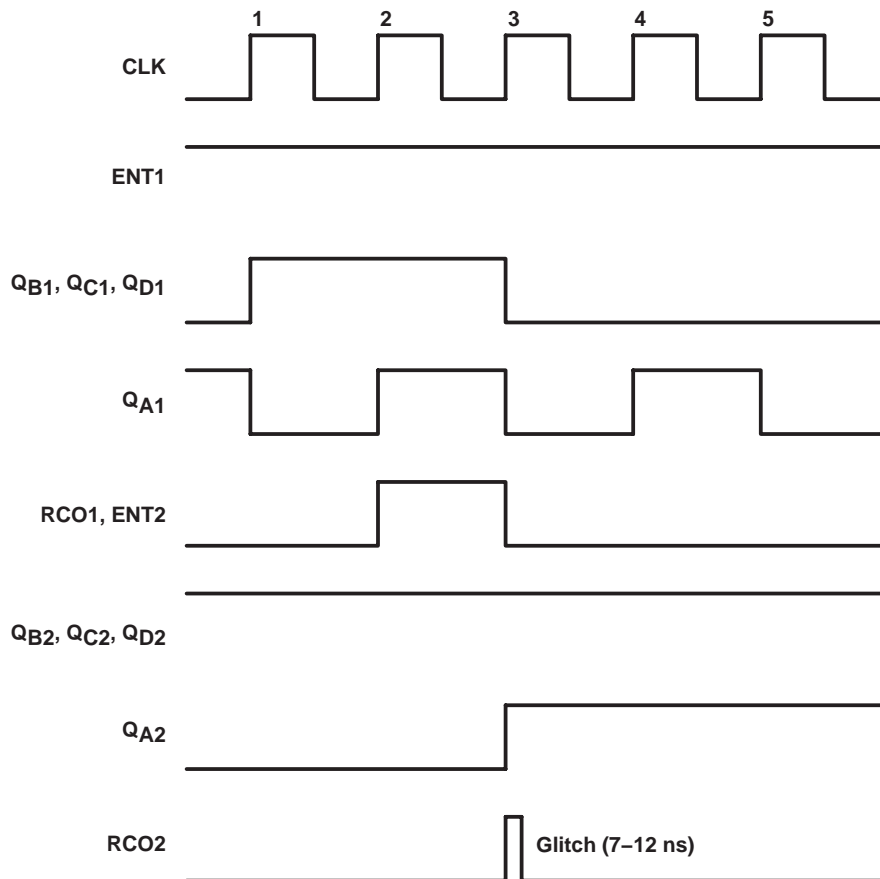

Figure 3

The glitch causes a problem in the next stage (stage three) if the glitch is still present when the next rising clock edge appears (clock pulse 4). To ensure that this does not happen, the clock frequency must be less than the inverse of the sum of the clock-to-RCO propagation delay and the glitch duration ( $t_g$ ). In other words,  $f_{max} = 1/(t_{pd} \text{ CLK-to-RCO} + t_g)$ . For example, at 25°C at 4.5-V  $V_{CC}$ , the clock-to-RCO propagation delay is 43 ns and the maximum duration of the glitch is 12 ns. Therefore, the maximum clock frequency that the cascaded counters can use is 18 MHz. The following tables contain the  $f_{clock}$ ,  $t_w$ , and  $f_{max}$  specifications for applications that use more than two 'HC163 devices cascaded together.

# SN54HC163, SN74HC163 4-BIT SYNCHRONOUS BINARY COUNTERS

SCLS298D – JANUARY 1996 – REVISED – OCTOBER 2003

## APPLICATION INFORMATION

### n-bit synchronous counters (continued)

**timing requirements over recommended operating free-air temperature range (unless otherwise noted)**

	V <sub>CC</sub>	T <sub>A</sub> = 25°C		SN54HC163		SN74HC163		UNIT
		MIN	MAX	MIN	MAX	MIN	MAX	
f <sub>clock</sub> Clock frequency	2 V		3.6		2.5		2.9	MHz
	4.5 V		18		12		14	
	6 V		21		14		17	
t <sub>w</sub> Pulse duration, CLK high or low	2 V	140		200		170		ns
	4.5 V	28		40		36		
	6 V	24		36		30		

**switching characteristics over recommended operating free-air temperature range, C<sub>L</sub> = 50 pF (unless otherwise noted) (see Note 4)**

PARAMETER	FROM (INPUT)	TO (OUTPUT)	V <sub>CC</sub>	T <sub>A</sub> = 25°C		SN54HC163		SN74HC163		UNIT
				MIN	MAX	MIN	MAX	MIN	MAX	
f <sub>max</sub>			2 V	3.6		2.5		2.9		MHz
			4.5 V	18		12		14		
			6 V	21		14		17		

NOTE 4: These limits apply only to applications that use more than two 'HC163 devices cascaded together.

If the 'HC163 devices are used as a single unit, or only two cascaded together, then the maximum clock frequency that the devices can use is not limited because of the glitch. In these situations, the devices can be operated at the maximum specifications.

A glitch can appear on RCO of a single 'HC163 device, depending on the relationship of ENT to CLK. Any application that uses RCO to drive any input, except an ENT of another cascaded 'HC163 device, must take this into consideration.

**PACKAGING INFORMATION**

Orderable Device	Status <sup>(1)</sup>	Package Type	Package Drawing	Pins	Package Qty	Eco Plan <sup>(2)</sup>	Lead/Ball Finish	MSL Peak Temp <sup>(3)</sup>
86076012A	ACTIVE	LCCC	FK	20	1	TBD	POST-PLATE	N / A for Pkg Type
8607601EA	ACTIVE	CDIP	J	16	1	TBD	A42 SNPB	N / A for Pkg Type
8607601FA	ACTIVE	CFP	W	16	1	TBD	A42	N / A for Pkg Type
JM38510/66304BEA	ACTIVE	CDIP	J	16	1	TBD	A42 SNPB	N / A for Pkg Type
SN54HC163J	ACTIVE	CDIP	J	16	1	TBD	A42 SNPB	N / A for Pkg Type
SN74HC163D	ACTIVE	SOIC	D	16	40	Green (RoHS & no Sb/Br)	CU NIPDAU	Level-1-260C-UNLIM
SN74HC163DBR	ACTIVE	SSOP	DB	16	2000	Green (RoHS & no Sb/Br)	CU NIPDAU	Level-1-260C-UNLIM
SN74HC163DBRE4	ACTIVE	SSOP	DB	16	2000	Green (RoHS & no Sb/Br)	CU NIPDAU	Level-1-260C-UNLIM
SN74HC163DBRG4	ACTIVE	SSOP	DB	16	2000	Green (RoHS & no Sb/Br)	CU NIPDAU	Level-1-260C-UNLIM
SN74HC163DE4	ACTIVE	SOIC	D	16	40	Green (RoHS & no Sb/Br)	CU NIPDAU	Level-1-260C-UNLIM
SN74HC163DG4	ACTIVE	SOIC	D	16	40	Green (RoHS & no Sb/Br)	CU NIPDAU	Level-1-260C-UNLIM
SN74HC163DR	ACTIVE	SOIC	D	16	2500	Green (RoHS & no Sb/Br)	CU NIPDAU	Level-1-260C-UNLIM
SN74HC163DRE4	ACTIVE	SOIC	D	16	2500	Green (RoHS & no Sb/Br)	CU NIPDAU	Level-1-260C-UNLIM
SN74HC163DRG4	ACTIVE	SOIC	D	16	2500	Green (RoHS & no Sb/Br)	CU NIPDAU	Level-1-260C-UNLIM
SN74HC163DT	ACTIVE	SOIC	D	16	250	Green (RoHS & no Sb/Br)	CU NIPDAU	Level-1-260C-UNLIM
SN74HC163DTE4	ACTIVE	SOIC	D	16	250	Green (RoHS & no Sb/Br)	CU NIPDAU	Level-1-260C-UNLIM
SN74HC163DTG4	ACTIVE	SOIC	D	16	250	Green (RoHS & no Sb/Br)	CU NIPDAU	Level-1-260C-UNLIM
SN74HC163N	ACTIVE	PDIP	N	16	25	Pb-Free (RoHS)	CU NIPDAU	N / A for Pkg Type
SN74HC163NE4	ACTIVE	PDIP	N	16	25	Pb-Free (RoHS)	CU NIPDAU	N / A for Pkg Type
SN74HC163NSR	ACTIVE	SO	NS	16	2000	Green (RoHS & no Sb/Br)	CU NIPDAU	Level-1-260C-UNLIM
SN74HC163NSRE4	ACTIVE	SO	NS	16	2000	Green (RoHS & no Sb/Br)	CU NIPDAU	Level-1-260C-UNLIM
SN74HC163NSRG4	ACTIVE	SO	NS	16	2000	Green (RoHS & no Sb/Br)	CU NIPDAU	Level-1-260C-UNLIM
SN74HC163PW	ACTIVE	TSSOP	PW	16	90	Green (RoHS & no Sb/Br)	CU NIPDAU	Level-1-260C-UNLIM
SN74HC163PWE4	ACTIVE	TSSOP	PW	16	90	Green (RoHS & no Sb/Br)	CU NIPDAU	Level-1-260C-UNLIM
SN74HC163PWG4	ACTIVE	TSSOP	PW	16	90	Green (RoHS & no Sb/Br)	CU NIPDAU	Level-1-260C-UNLIM
SN74HC163PWR	ACTIVE	TSSOP	PW	16	2000	Green (RoHS & no Sb/Br)	CU NIPDAU	Level-1-260C-UNLIM
SN74HC163PWRE4	ACTIVE	TSSOP	PW	16	2000	Green (RoHS & no Sb/Br)	CU NIPDAU	Level-1-260C-UNLIM

Orderable Device	Status <sup>(1)</sup>	Package Type	Package Drawing	Pins	Package Qty	Eco Plan <sup>(2)</sup>	Lead/Ball Finish	MSL Peak Temp <sup>(3)</sup>
SN74HC163PWRG4	ACTIVE	TSSOP	PW	16	2000	Green (RoHS & no Sb/Br)	CU NIPDAU	Level-1-260C-UNLIM
SN74HC163PWT	ACTIVE	TSSOP	PW	16	250	Green (RoHS & no Sb/Br)	CU NIPDAU	Level-1-260C-UNLIM
SN74HC163PWTE4	ACTIVE	TSSOP	PW	16	250	Green (RoHS & no Sb/Br)	CU NIPDAU	Level-1-260C-UNLIM
SN74HC163PWTG4	ACTIVE	TSSOP	PW	16	250	Green (RoHS & no Sb/Br)	CU NIPDAU	Level-1-260C-UNLIM
SNJ54HC163FK	ACTIVE	LCCC	FK	20	1	TBD	POST-PLATE	N / A for Pkg Type
SNJ54HC163J	ACTIVE	CDIP	J	16	1	TBD	A42 SNPB	N / A for Pkg Type
SNJ54HC163W	ACTIVE	CFP	W	16	1	TBD	A42	N / A for Pkg Type

<sup>(1)</sup> The marketing status values are defined as follows:

**ACTIVE:** Product device recommended for new designs.

**LIFEBUY:** TI has announced that the device will be discontinued, and a lifetime-buy period is in effect.

**NRND:** Not recommended for new designs. Device is in production to support existing customers, but TI does not recommend using this part in a new design.

**PREVIEW:** Device has been announced but is not in production. Samples may or may not be available.

**OBSELETE:** TI has discontinued the production of the device.

<sup>(2)</sup> Eco Plan - The planned eco-friendly classification: Pb-Free (RoHS), Pb-Free (RoHS Exempt), or Green (RoHS & no Sb/Br) - please check <http://www.ti.com/productcontent> for the latest availability information and additional product content details.

**TBD:** The Pb-Free/Green conversion plan has not been defined.

**Pb-Free (RoHS):** TI's terms "Lead-Free" or "Pb-Free" mean semiconductor products that are compatible with the current RoHS requirements for all 6 substances, including the requirement that lead not exceed 0.1% by weight in homogeneous materials. Where designed to be soldered at high temperatures, TI Pb-Free products are suitable for use in specified lead-free processes.

**Pb-Free (RoHS Exempt):** This component has a RoHS exemption for either 1) lead-based flip-chip solder bumps used between the die and package, or 2) lead-based die adhesive used between the die and leadframe. The component is otherwise considered Pb-Free (RoHS compatible) as defined above.

**Green (RoHS & no Sb/Br):** TI defines "Green" to mean Pb-Free (RoHS compatible), and free of Bromine (Br) and Antimony (Sb) based flame retardants (Br or Sb do not exceed 0.1% by weight in homogeneous material)

<sup>(3)</sup> MSL, Peak Temp. -- The Moisture Sensitivity Level rating according to the JEDEC industry standard classifications, and peak solder temperature.

**Important Information and Disclaimer:**The information provided on this page represents TI's knowledge and belief as of the date that it is provided. TI bases its knowledge and belief on information provided by third parties, and makes no representation or warranty as to the accuracy of such information. Efforts are underway to better integrate information from third parties. TI has taken and continues to take reasonable steps to provide representative and accurate information but may not have conducted destructive testing or chemical analysis on incoming materials and chemicals. TI and TI suppliers consider certain information to be proprietary, and thus CAS numbers and other limited information may not be available for release.

In no event shall TI's liability arising out of such information exceed the total purchase price of the TI part(s) at issue in this document sold by TI to Customer on an annual basis.

**OTHER QUALIFIED VERSIONS OF SN54HC163, SN74HC163 :**

- Automotive: [SN74HC163-Q1](#)

NOTE: Qualified Version Definitions:

- Automotive - Q100 devices qualified for high-reliability automotive applications targeting zero defects

**TAPE AND REEL INFORMATION**

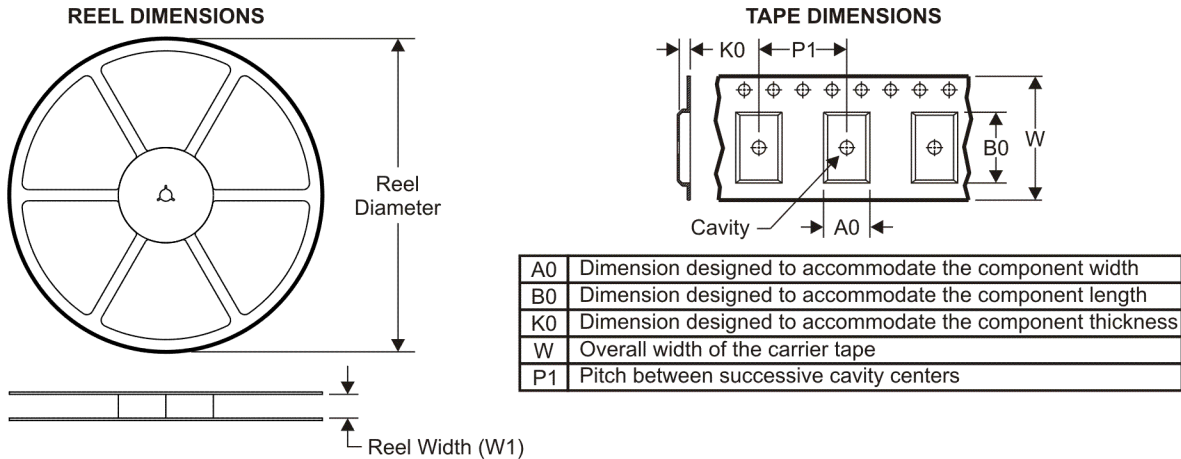

**QUADRANT ASSIGNMENTS FOR PIN 1 ORIENTATION IN TAPE**



\*All dimensions are nominal

Device	Package Type	Package Drawing	Pins	SPQ	Reel Diameter (mm)	Reel Width W1 (mm)	A0 (mm)	B0 (mm)	K0 (mm)	P1 (mm)	W (mm)	Pin1 Quadrant
SN74HC163DBR	SSOP	DB	16	2000	330.0	16.4	8.2	6.6	2.5	12.0	16.0	Q1
SN74HC163DR	SOIC	D	16	2500	330.0	16.4	6.5	10.3	2.1	8.0	16.0	Q1
SN74HC163NSR	SO	NS	16	2000	330.0	16.4	8.2	10.5	2.5	12.0	16.0	Q1
SN74HC163PWR	TSSOP	PW	16	2000	330.0	12.4	7.0	5.6	1.6	8.0	12.0	Q1

**TAPE AND REEL BOX DIMENSIONS**



\*All dimensions are nominal

Device	Package Type	Package Drawing	Pins	SPQ	Length (mm)	Width (mm)	Height (mm)
SN74HC163DBR	SSOP	DB	16	2000	346.0	346.0	33.0
SN74HC163DR	SOIC	D	16	2500	333.2	345.9	28.6
SN74HC163NSR	SO	NS	16	2000	346.0	346.0	33.0
SN74HC163PWR	TSSOP	PW	16	2000	346.0	346.0	29.0



PW (R-PDSO-G\*\*)

PLASTIC SMALL-OUTLINE PACKAGE

14 PINS SHOWN



4040064/F 01/97

- NOTES: A. All linear dimensions are in millimeters.  
 B. This drawing is subject to change without notice.  
 C. Body dimensions do not include mold flash or protrusion not to exceed 0,15.  
 D. Falls within JEDEC MO-153

FK (S-CQCC-N\*\*)

LEADLESS CERAMIC CHIP CARRIER

28 TERMINAL SHOWN

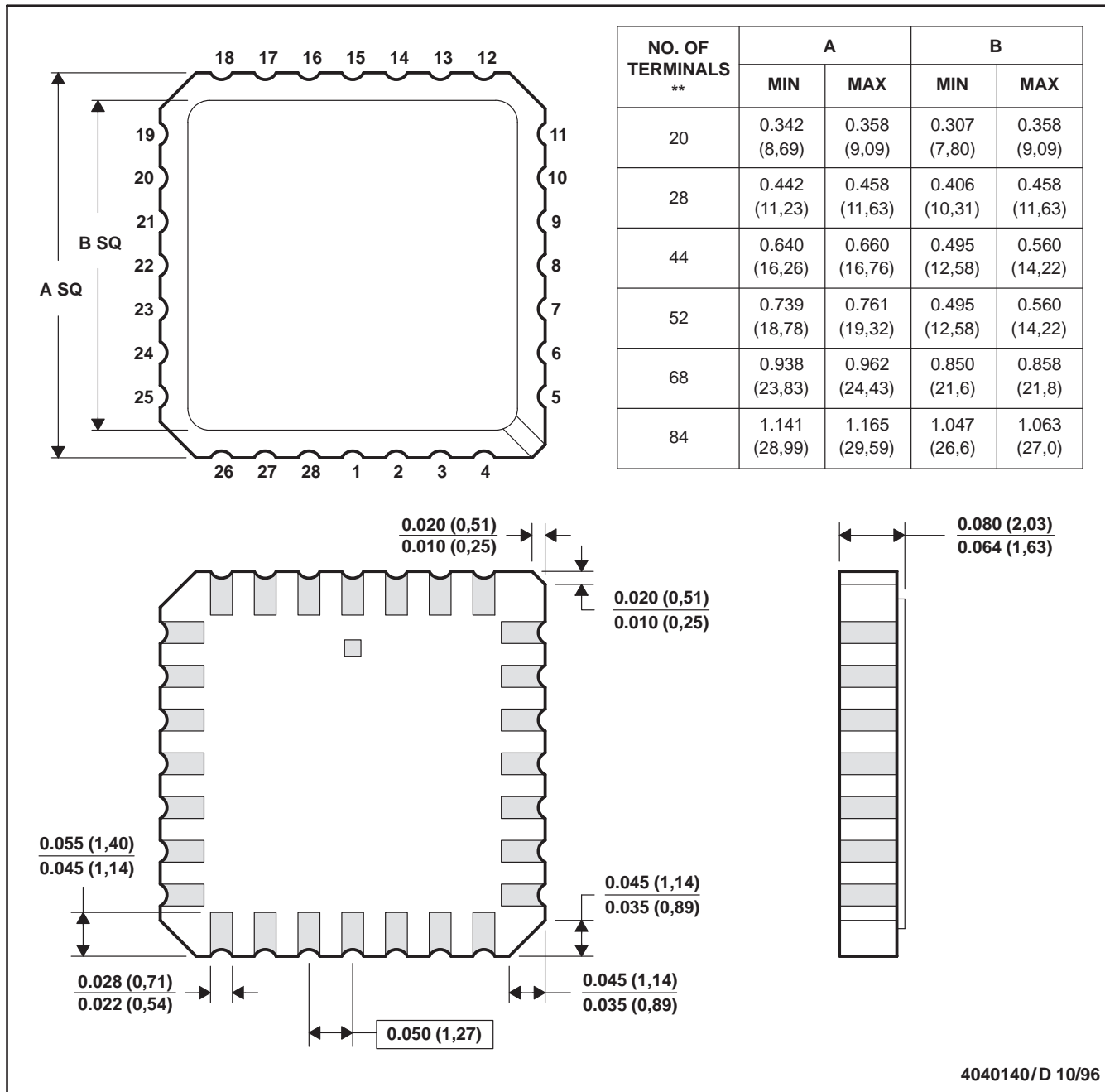

- NOTES:
- A. All linear dimensions are in inches (millimeters).
  - B. This drawing is subject to change without notice.
  - C. This package can be hermetically sealed with a metal lid.
  - D. The terminals are gold plated.
  - E. Falls within JEDEC MS-004

J (R-GDIP-T\*\*)

14 LEADS SHOWN

CERAMIC DUAL IN-LINE PACKAGE



DIM \ PINS **	14	16	18	20
A	0.300 (7,62) BSC	0.300 (7,62) BSC	0.300 (7,62) BSC	0.300 (7,62) BSC
B MAX	0.785 (19,94)	.840 (21,34)	0.960 (24,38)	1.060 (26,92)
B MIN	—	—	—	—
C MAX	0.300 (7,62)	0.300 (7,62)	0.310 (7,87)	0.300 (7,62)
C MIN	0.245 (6,22)	0.245 (6,22)	0.220 (5,59)	0.245 (6,22)



4040083/F 03/03

- NOTES:
- All linear dimensions are in inches (millimeters).
  - This drawing is subject to change without notice.
  - This package is hermetically sealed with a ceramic lid using glass frit.
  - Index point is provided on cap for terminal identification only on press ceramic glass frit seal only.
  - Falls within MIL STD 1835 GDIP1-T14, GDIP1-T16, GDIP1-T18 and GDIP1-T20.

# MECHANICAL DATA

NS (R-PDSO-G\*\*)

PLASTIC SMALL-OUTLINE PACKAGE

14-PINS SHOWN



- NOTES:
- A. All linear dimensions are in millimeters.
  - B. This drawing is subject to change without notice.
  - C. Body dimensions do not include mold flash or protrusion, not to exceed 0,15.

W (R-GDFP-F16)

CERAMIC DUAL FLATPACK

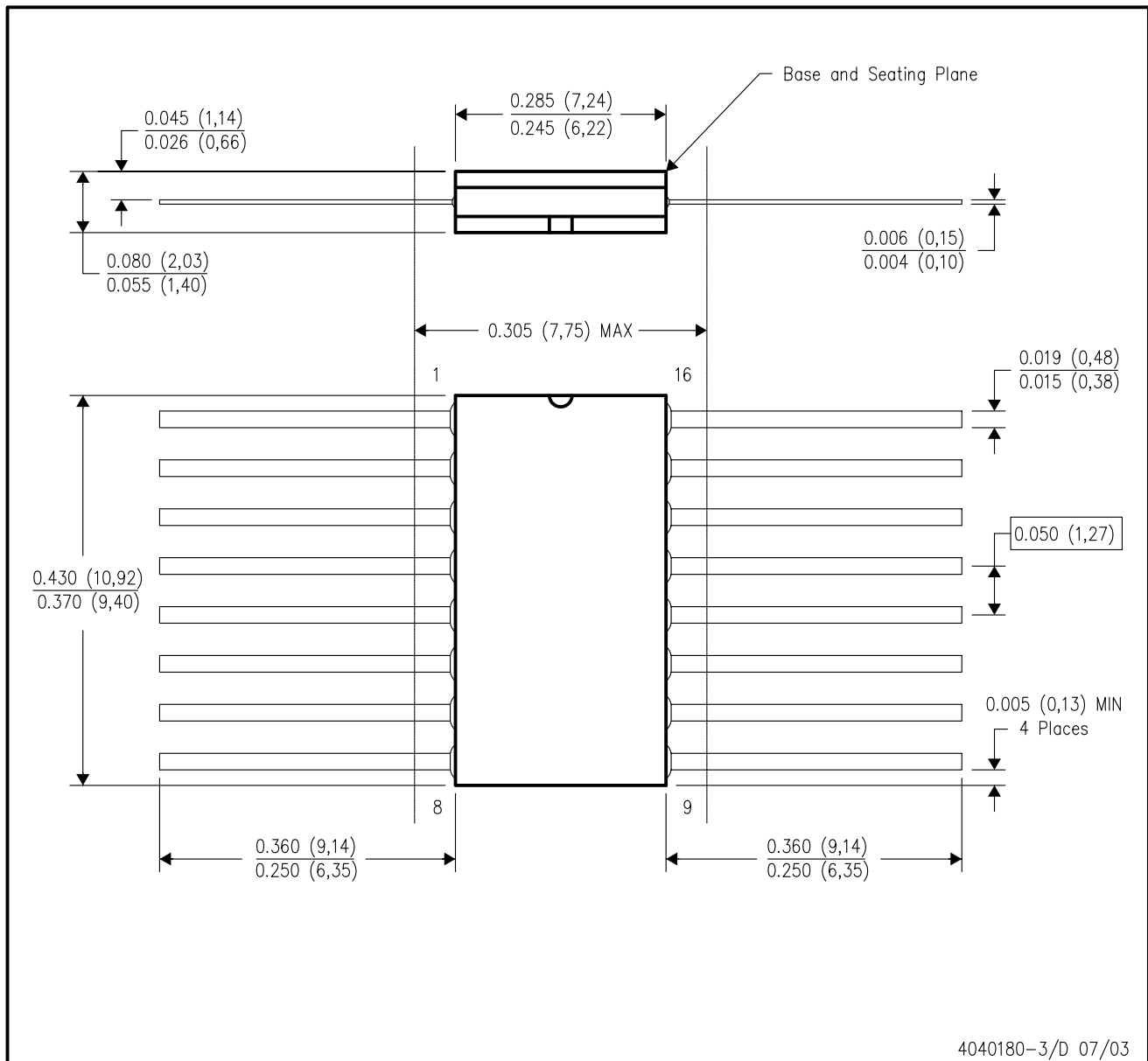

- NOTES:
- A. All linear dimensions are in inches (millimeters).
  - B. This drawing is subject to change without notice.
  - C. This package can be hermetically sealed with a ceramic lid using glass frit.
  - D. Index point is provided on cap for terminal identification only.
  - E. Falls within MIL STD 1835 GDFP1-F16 and JEDEC MO-092AC

D (R-PDSO-G16)

PLASTIC SMALL-OUTLINE PACKAGE

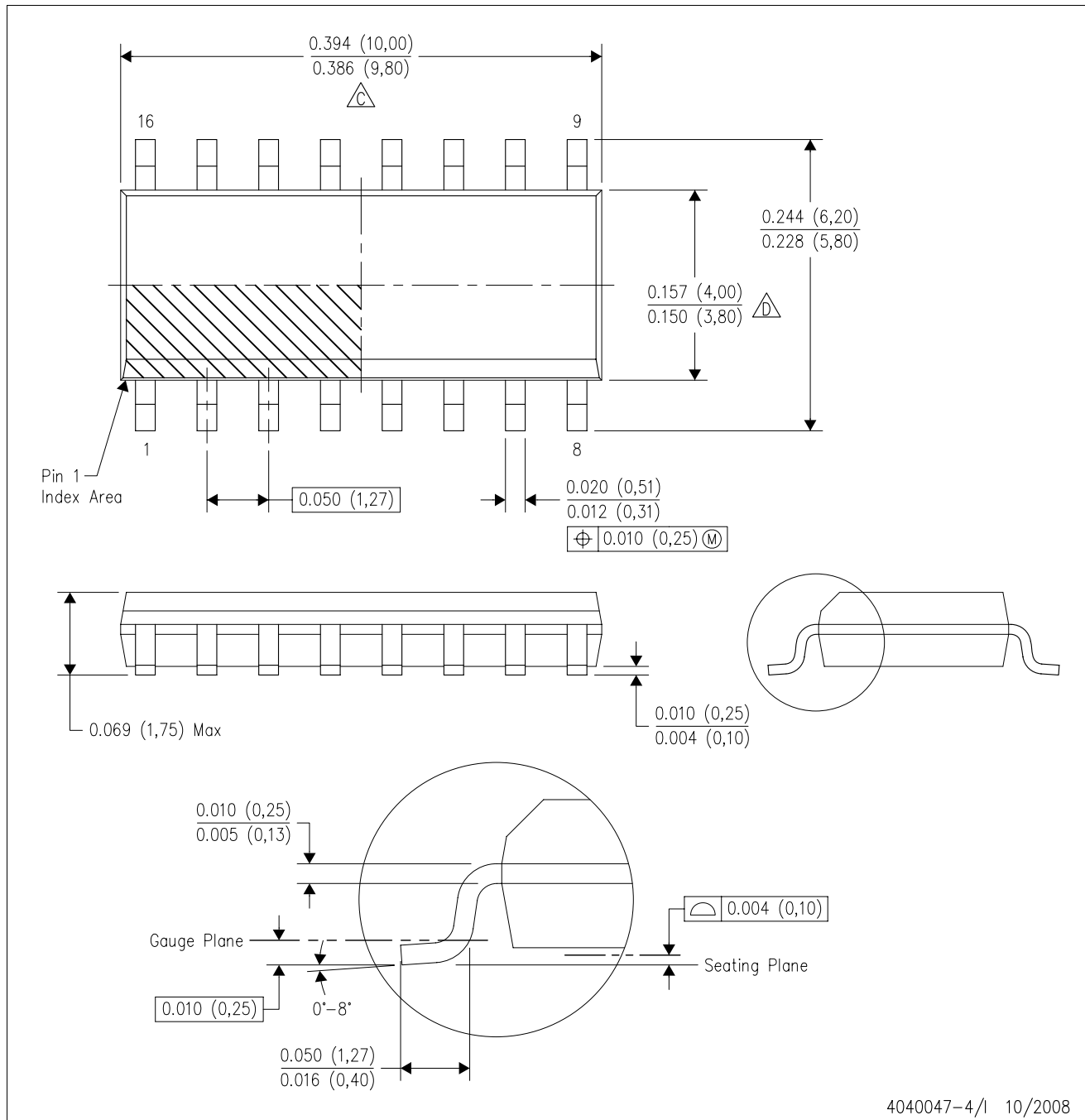

- NOTES:
- A. All linear dimensions are in inches (millimeters).
  - B. This drawing is subject to change without notice.
  - C. Body length does not include mold flash, protrusions, or gate burrs. Mold flash, protrusions, or gate burrs shall not exceed .006 (0,15) per end.
  - D. Body width does not include interlead flash. Interlead flash shall not exceed .017 (0,43) per side.
  - E. Reference JEDEC MS-012 variation AC.

D(R-PDSO-G16)

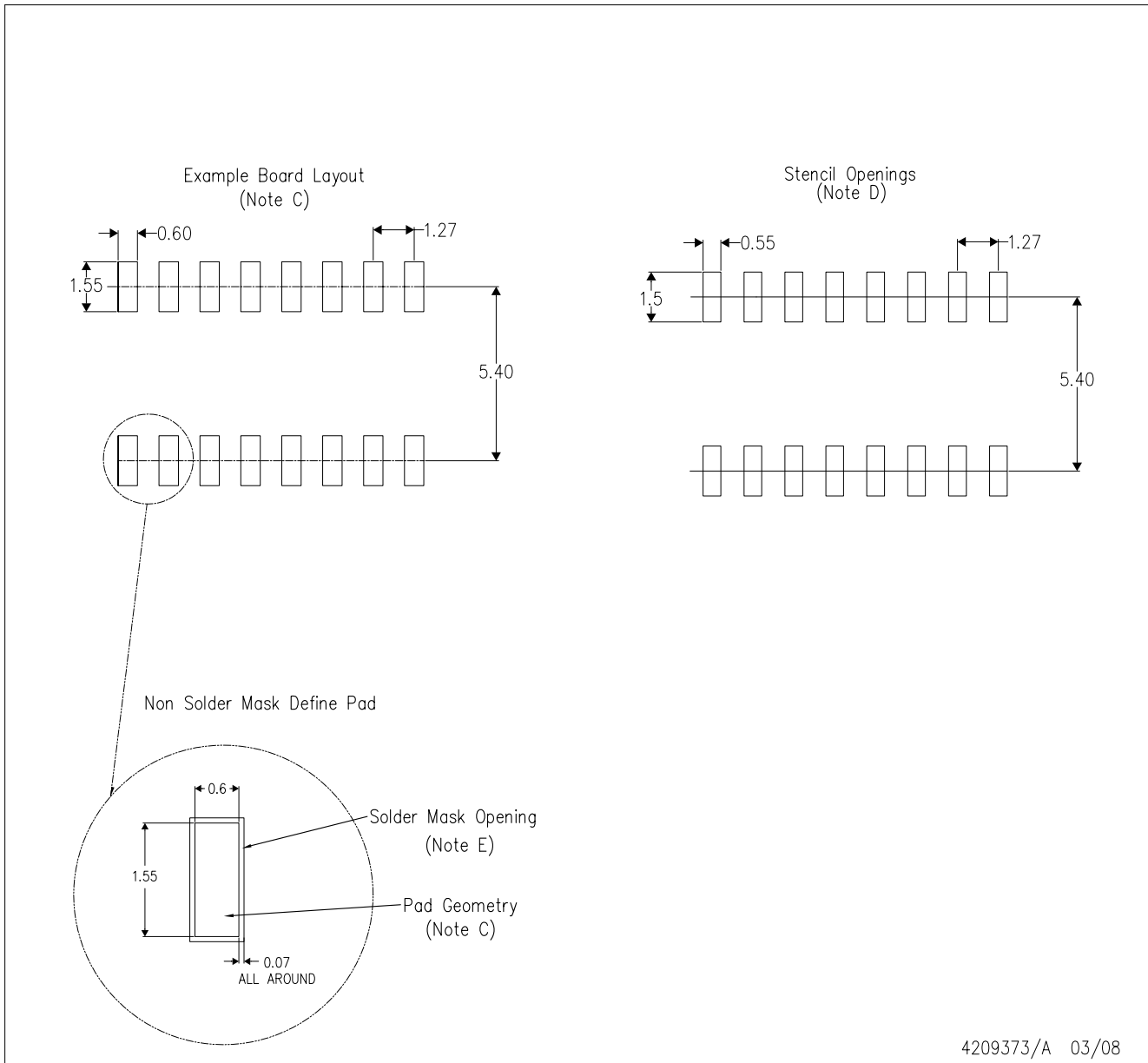

- NOTES:
- A. All linear dimensions are in millimeters.
  - B. This drawing is subject to change without notice.
  - C. Refer to IPC7351 for alternate board design.
  - D. Laser cutting apertures with trapezoidal walls and also rounding corners will offer better paste release. Customers should contact their board assembly site for stencil design recommendations. Refer to IPC-7525
  - E. Customers should contact their board fabrication site for solder mask tolerances between and around signal pads.

N (R-PDIP-T\*\*)

PLASTIC DUAL-IN-LINE PACKAGE

16 PINS SHOWN



- NOTES:
- A. All linear dimensions are in inches (millimeters).
  - B. This drawing is subject to change without notice.
  - Falls within JEDEC MS-001, except 18 and 20 pin minimum body length (Dim A).
  - The 20 pin end lead shoulder width is a vendor option, either half or full width.

## IMPORTANT NOTICE

Texas Instruments Incorporated and its subsidiaries (TI) reserve the right to make corrections, modifications, enhancements, improvements, and other changes to its products and services at any time and to discontinue any product or service without notice. Customers should obtain the latest relevant information before placing orders and should verify that such information is current and complete. All products are sold subject to TI's terms and conditions of sale supplied at the time of order acknowledgment.

TI warrants performance of its hardware products to the specifications applicable at the time of sale in accordance with TI's standard warranty. Testing and other quality control techniques are used to the extent TI deems necessary to support this warranty. Except where mandated by government requirements, testing of all parameters of each product is not necessarily performed.

TI assumes no liability for applications assistance or customer product design. Customers are responsible for their products and applications using TI components. To minimize the risks associated with customer products and applications, customers should provide adequate design and operating safeguards.

TI does not warrant or represent that any license, either express or implied, is granted under any TI patent right, copyright, mask work right, or other TI intellectual property right relating to any combination, machine, or process in which TI products or services are used. Information published by TI regarding third-party products or services does not constitute a license from TI to use such products or services or a warranty or endorsement thereof. Use of such information may require a license from a third party under the patents or other intellectual property of the third party, or a license from TI under the patents or other intellectual property of TI.

Reproduction of TI information in TI data books or data sheets is permissible only if reproduction is without alteration and is accompanied by all associated warranties, conditions, limitations, and notices. Reproduction of this information with alteration is an unfair and deceptive business practice. TI is not responsible or liable for such altered documentation. Information of third parties may be subject to additional restrictions.

Resale of TI products or services with statements different from or beyond the parameters stated by TI for that product or service voids all express and any implied warranties for the associated TI product or service and is an unfair and deceptive business practice. TI is not responsible or liable for any such statements.

TI products are not authorized for use in safety-critical applications (such as life support) where a failure of the TI product would reasonably be expected to cause severe personal injury or death, unless officers of the parties have executed an agreement specifically governing such use. Buyers represent that they have all necessary expertise in the safety and regulatory ramifications of their applications, and acknowledge and agree that they are solely responsible for all legal, regulatory and safety-related requirements concerning their products and any use of TI products in such safety-critical applications, notwithstanding any applications-related information or support that may be provided by TI. Further, Buyers must fully indemnify TI and its representatives against any damages arising out of the use of TI products in such safety-critical applications.

TI products are neither designed nor intended for use in military/aerospace applications or environments unless the TI products are specifically designated by TI as military-grade or "enhanced plastic." Only products designated by TI as military-grade meet military specifications. Buyers acknowledge and agree that any such use of TI products which TI has not designated as military-grade is solely at the Buyer's risk, and that they are solely responsible for compliance with all legal and regulatory requirements in connection with such use.

TI products are neither designed nor intended for use in automotive applications or environments unless the specific TI products are designated by TI as compliant with ISO/TS 16949 requirements. Buyers acknowledge and agree that, if they use any non-designated products in automotive applications, TI will not be responsible for any failure to meet such requirements.

Following are URLs where you can obtain information on other Texas Instruments products and application solutions:

### Products

Amplifiers	<a href="http://amplifier.ti.com">amplifier.ti.com</a>
Data Converters	<a href="http://dataconverter.ti.com">dataconverter.ti.com</a>
DSP	<a href="http://dsp.ti.com">dsp.ti.com</a>
Clocks and Timers	<a href="http://www.ti.com/clocks">www.ti.com/clocks</a>
Interface	<a href="http://interface.ti.com">interface.ti.com</a>
Logic	<a href="http://logic.ti.com">logic.ti.com</a>
Power Mgmt	<a href="http://power.ti.com">power.ti.com</a>
Microcontrollers	<a href="http://microcontroller.ti.com">microcontroller.ti.com</a>
RFID	<a href="http://www.ti-rfid.com">www.ti-rfid.com</a>
RF/IF and ZigBee® Solutions	<a href="http://www.ti.com/lprf">www.ti.com/lprf</a>

### Applications

Audio	<a href="http://www.ti.com/audio">www.ti.com/audio</a>
Automotive	<a href="http://www.ti.com/automotive">www.ti.com/automotive</a>
Broadband	<a href="http://www.ti.com/broadband">www.ti.com/broadband</a>
Digital Control	<a href="http://www.ti.com/digitalcontrol">www.ti.com/digitalcontrol</a>
Medical	<a href="http://www.ti.com/medical">www.ti.com/medical</a>
Military	<a href="http://www.ti.com/military">www.ti.com/military</a>
Optical Networking	<a href="http://www.ti.com/opticalnetwork">www.ti.com/opticalnetwork</a>
Security	<a href="http://www.ti.com/security">www.ti.com/security</a>
Telephony	<a href="http://www.ti.com/telephony">www.ti.com/telephony</a>
Video & Imaging	<a href="http://www.ti.com/video">www.ti.com/video</a>
Wireless	<a href="http://www.ti.com/wireless">www.ti.com/wireless</a>

Mailing Address: Texas Instruments, Post Office Box 655303, Dallas, Texas 75265  
Copyright © 2008, Texas Instruments Incorporated