

## FEATURES

- Member of the Texas Instruments Widebus+™ Family
- TI-OPC™ Circuitry Limits Ringing on Unevenly Loaded Backplanes
- OEC™ Circuitry Improves Signal Integrity and Reduces Electromagnetic Interference
- Bidirectional Interface Between GTLP Signal Levels and LVTTTL Logic Levels
- LVTTTL Interfaces Are 5-V Tolerant
- Medium-Drive GTLP Outputs (50 mA)
- LVTTTL Outputs (–24 mA/24 mA)
- GTLP Rise and Fall Times Designed for Optimal Data-Transfer Rate and Signal Integrity in Distributed Loads
- I<sub>off</sub>, Power-Up 3-State, and BIAS V<sub>CC</sub> Support Live Insertion
- Bus Hold on A-Port Data Inputs
- Distributed V<sub>CC</sub> and GND Pins Minimize High-Speed Switching Noise
- Latch-Up Performance Exceeds 100 mA Per JESD 78, Class II

## DESCRIPTION/ORDERING INFORMATION

The SN74GTLPH32945 is a medium-drive, 32-bit bus transceiver that provides LVTTTL-to-GTLP and GTLP-to-LVTTTL signal-level translation. It is partitioned as four 8-bit transceivers. The device provides a high-speed interface between cards operating at LVTTTL logic levels and a backplane operating at GTLP signal levels. High-speed (about three times faster than standard TTL or LVTTTL) backplane operation is a direct result of GTLP's reduced output swing (<1 V), reduced input threshold levels, improved differential input, OEC circuitry, and TI-OPC circuitry. Improved GTLP OEC and TI-OPC circuits minimize bus-settling time and have been designed and tested using several backplane models. The medium drive allows incident-wave switching in heavily loaded backplanes with equivalent load impedance down to 19 Ω.

GTLP is the Texas Instruments derivative of the Gunning Transceiver Logic (GTL) JEDEC standard JESD 8-3. The ac specification of the SN74GTLPH32945 is given only at the preferred higher noise margin GTLP, but the user has the flexibility of using this device at either GTL (V<sub>TT</sub> = 1.2 V and V<sub>REF</sub> = 0.8 V) or GTLP (V<sub>TT</sub> = 1.5 V and V<sub>REF</sub> = 1 V) signal levels.

Normally, the B port operates at GTLP signal levels. The A-port and control inputs operate at LVTTTL logic levels, but are 5-V tolerant and are compatible with TTL and 5-V CMOS inputs. V<sub>REF</sub> is the B-port differential input reference voltage.

This device is fully specified for live-insertion applications using I<sub>off</sub>, power-up 3-state, and BIAS V<sub>CC</sub>. The I<sub>off</sub> circuitry disables the outputs, preventing damaging current backflow through the device when it is powered down. The power-up 3-state circuitry places the outputs in the high-impedance state during power up and power down, which prevents driver conflict. The BIAS V<sub>CC</sub> circuitry precharges and preconditions the B-port input/output connections, preventing disturbance of active data on the backplane during card insertion or removal, and permits true live-insertion capability.

This GTLP device features TI-OPC circuitry, which actively limits overshoot caused by improperly terminated backplanes, unevenly distributed cards, or empty slots during low-to-high signal transitions. This improves signal integrity, which allows adequate noise margin to be maintained at higher frequencies.

Active bus-hold circuitry holds unused or undriven LVTTTL data inputs at a valid logic state. Use of pullup or pulldown resistors with the bus-hold circuitry is not recommended.

## ORDERING INFORMATION

T <sub>A</sub>	PACKAGE <sup>(1)</sup>		ORDERABLE PART NUMBER	TOP-SIDE MARKING
–40°C to 85°C	LFBGA – GKE	Tape and reel	SN74GTLPH32945KR	GM45

(1) Package drawings, standard packing quantities, thermal data, symbolization, and PCB design guidelines are available at [www.ti.com/sc/package](http://www.ti.com/sc/package).



Please be aware that an important notice concerning availability, standard warranty, and use in critical applications of Texas Instruments semiconductor products and disclaimers thereto appears at the end of this data sheet.

Widebus+, TI-OPC, OEC are trademarks of Texas Instruments.

**DESCRIPTION/ORDERING INFORMATION (CONTINUED)**

When  $V_{CC}$  is between 0 and 1.5 V, the device is in the high-impedance state during power up or power down. However, to ensure the high-impedance state above 1.5 V, the output-enable ( $\overline{OE}$ ) input should be tied to  $V_{CC}$  through a pullup resistor; the minimum value of the resistor is determined by the current-sinking capability of the driver.

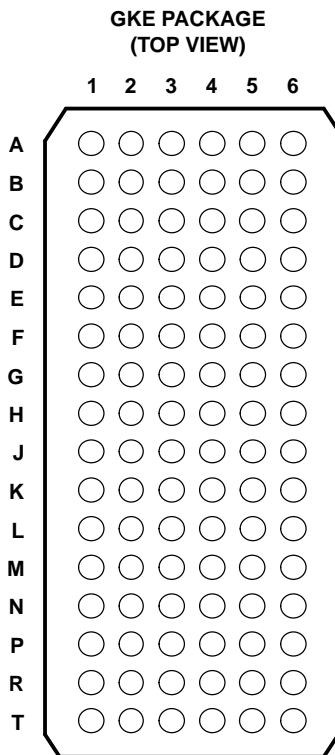

**TERMINAL ASSIGNMENTS**

	1	2	3	4	5	6
<b>A</b>	1A2	1A1	1DIR	$1\overline{OE}$	1B1	1B2
<b>B</b>	1A4	1A3	GND	GND	1B3	1B4
<b>C</b>	1A6	1A5	$1V_{CC}$	$1BIAS V_{CC}$	1B5	1B6
<b>D</b>	1A8	1A7	GND	GND	1B7	1B8
<b>E</b>	2A2	2A1	GND	GND	2B1	2B2
<b>F</b>	2A4	2A3	$1V_{CC}$	$1V_{REF}$	2B3	2B4
<b>G</b>	2A6	2A5	GND	GND	2B5	2B6
<b>H</b>	2A7	2A8	2DIR	$2\overline{OE}$	2B8	2B7
<b>J</b>	3A2	3A1	3DIR	$3\overline{OE}$	3B1	3B2
<b>K</b>	3A4	3A3	GND	GND	3B3	3B4
<b>L</b>	3A6	3A5	$2V_{CC}$	$2BIAS V_{CC}$	3B5	3B6
<b>M</b>	3A8	3A7	GND	GND	3B7	3B8
<b>N</b>	4A2	4A1	GND	GND	4B1	4B2
<b>P</b>	4A4	4A3	$2V_{CC}$	$2V_{REF}$	4B3	4B4
<b>R</b>	4A6	4A5	GND	GND	4B5	4B6
<b>T</b>	4A7	4A8	4DIR	$4\overline{OE}$	4B8	4B7

## FUNCTIONAL DESCRIPTION

The SN74GTLPH32945 is a medium-drive (50-mA), 32-bit bus transceiver partitioned as four 8-bit segments and is designed for asynchronous communication between data buses. The device transmits data from the A port to the B port or from the B port to the A port, depending on the logic level at the direction-control (DIR) input.  $\overline{OE}$  can be used to disable the device so the buses are effectively isolated. Data polarity is noninverting.

For A-to-B data flow, when  $\overline{OE}$  is low and DIR is high, the B outputs take on the logic value of the A inputs. When  $\overline{OE}$  is high, the outputs are in the high-impedance state.

The data flow for B to A is similar to that of A to B, except  $\overline{OE}$  and DIR are low.

FUNCTION TABLE

INPUTS		OUTPUT	MODE
$\overline{OE}$	DIR		
H	X	Z	Isolation
L	L	B data to A port	True transparent
L	H	A data to B port	

LOGIC DIAGRAM (POSITIVE LOGIC)

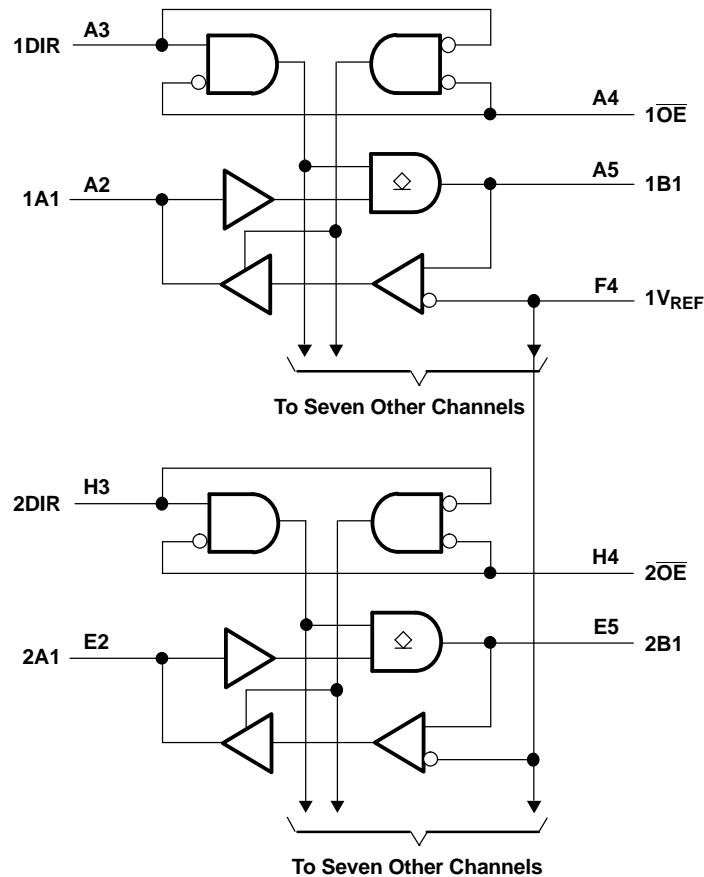

(1)  $1V_{CC}$  and  $1BIAS V_{CC}$  are associated with these channels.

LOGIC DIAGRAM (POSITIVE LOGIC) (CONTINUED)<sup>(1)</sup>

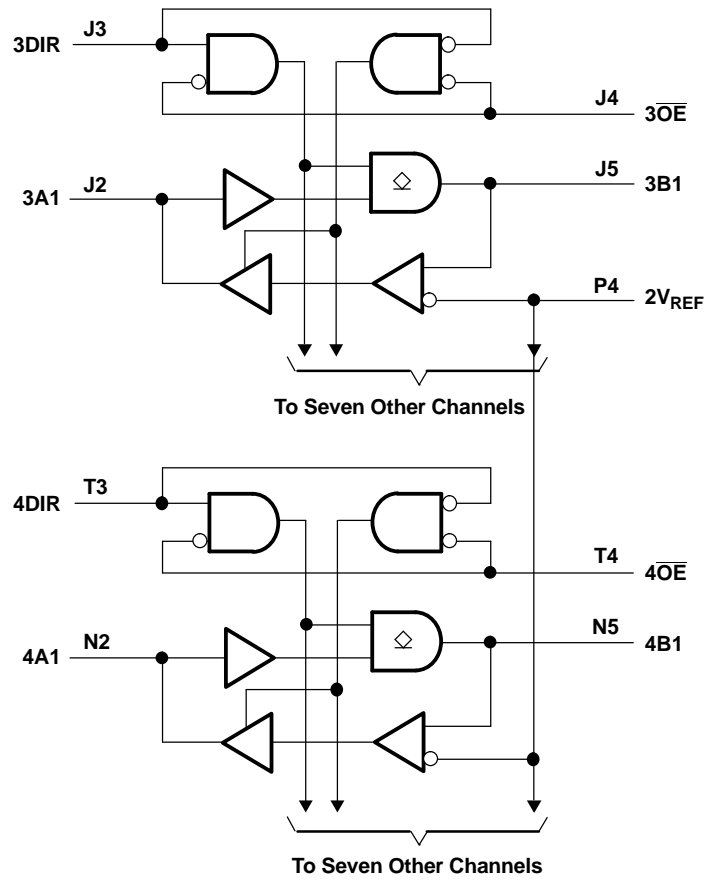

(1)  $2V_{CC}$  and  $2BIAS V_{CC}$  are associated with these channels.

### Absolute Maximum Ratings<sup>(1)</sup>

over operating free-air temperature range (unless otherwise noted)

		MIN	MAX	UNIT	
$V_{CC}$ BIAS $V_{CC}$	Supply voltage range	-0.5	4.6	V	
$V_I$	Input voltage range <sup>(2)</sup>	A-port and control inputs	-0.5	7	V
		B port and $V_{REF}$	-0.5	4.6	
$V_O$	Voltage range applied to any output in the high-impedance or power-off state <sup>(2)</sup>	A port	-0.5	7	V
		B port	-0.5	4.6	
$I_O$	Current into any output in the low state	A port		48	mA
		B port		100	
$I_O$	Current into any A-port output in the high state <sup>(3)</sup>		48	mA	
	Continuous current through each $V_{CC}$ or GND		±100	mA	
$I_{IK}$	Input clamp current	$V_I < 0$	-50	mA	
$I_{OK}$	Output clamp current	$V_O < 0$	-50	mA	
$\theta_{JA}$	Package thermal impedance <sup>(4)</sup>		40	°C/W	
$T_{stg}$	Storage temperature range	-65	150	°C	

- (1) Stresses beyond those listed under "absolute maximum ratings" may cause permanent damage to the device. These are stress ratings only, and functional operation of the device at these or any other conditions beyond those indicated under "recommended operating conditions" is not implied. Exposure to absolute-maximum-rated conditions for extended periods may affect device reliability.
- (2) The input and output negative-voltage ratings may be exceeded if the input and output clamp-current ratings are observed.
- (3) This current flows only when the output is in the high state and  $V_O > V_{CC}$ .
- (4) The package thermal impedance is calculated in accordance with JESD 51-7.

# SN74GTLPH32945

## 32-BIT LVTTTL-TO-GTLP BUS TRANSCEIVER

SCES293C–OCTOBER 1999–REVISED JUNE 2005

### Recommended Operating Conditions<sup>(1)(2)(3)(4)</sup>

		MIN	NOM	MAX	UNIT	
$V_{CC}$ , BIAS $V_{CC}$	Supply voltage	3.15	3.3	3.45	V	
$V_{TT}$	Termination voltage	GTL	1.14	1.2	1.26	V
		GTLP	1.35	1.5	1.65	
$V_{REF}$	Reference voltage	GTL	0.74	0.8	0.87	V
		GTLP	0.87	1	1.1	
$V_I$	Input voltage	B port		$V_{TT}$	V	
		Except B port		$V_{CC}$		
$V_{IH}$	High-level input voltage	B port	$V_{REF} + 0.05$		V	
		Except B port	2			
$V_{IL}$	Low-level input voltage	B port		$V_{REF} - 0.05$	V	
		Except B port		0.8		
$I_{IK}$	Input clamp current			-18	mA	
$I_{OH}$	High-level output current	A port		-24	mA	
$I_{OL}$	Low-level output current	A port		24	mA	
		B port		50		
$\Delta t/\Delta v$	Input transition rise or fall rate	Outputs enabled		10	ns/V	
$\Delta t/\Delta V_{CC}$	Power-up ramp rate	20			$\mu\text{s}/\text{V}$	
$T_A$	Operating free-air temperature	-40		85	$^{\circ}\text{C}$	

- (1) All unused inputs of the device must be held at  $V_{CC}$  or GND to ensure proper device operation. Refer to the TI application report, *Implications of Slow or Floating CMOS Inputs*, literature number SCBA004.
- (2) Proper connection sequence for use of the B-port I/O precharge feature is GND and BIAS  $V_{CC} = 3.3$  V first, I/O second, and  $V_{CC} = 3.3$  V last, because the BIAS  $V_{CC}$  precharge circuitry is disabled when any  $V_{CC}$  pin is connected. The control and  $V_{REF}$  inputs can be connected anytime, but normally are connected during the I/O stage. If B-port precharge is not required, any connection sequence is acceptable but, generally, GND is connected first.
- (3)  $V_{TT}$  and  $R_{TT}$  can be adjusted to accommodate backplane impedances if the dc recommended  $I_{OL}$  ratings are not exceeded.
- (4)  $V_{REF}$  can be adjusted to optimize noise margins, but normally is two-thirds  $V_{TT}$ . TI-OPC circuitry is enabled in the A-to-B direction and is activated when  $V_{TT} > 0.7$  V above  $V_{REF}$ . If operated in the A-to-B direction,  $V_{REF}$  should be set to within 0.6 V of  $V_{TT}$  to minimize current drain.

## Electrical Characteristics

over recommended operating free-air temperature range for GTLP (unless otherwise noted)

PARAMETER		TEST CONDITIONS			MIN	TYP <sup>(1)</sup>	MAX	UNIT	
$V_{IK}$		$V_{CC} = 3.15\text{ V}$ , $I_I = -18\text{ mA}$					-1.2	V	
$V_{OH}$	A port	$V_{CC} = 3.15\text{ V to } 3.45\text{ V}$ , $I_{OH} = -100\text{ }\mu\text{A}$			$V_{CC} - 0.2$			V	
		$V_{CC} = 3.15\text{ V}$ , $I_{OH} = -12\text{ mA}$			2.4				
		$V_{CC} = 3.15\text{ V}$ , $I_{OH} = -24\text{ mA}$			2				
$V_{OL}$	A port	$V_{CC} = 3.15\text{ V to } 3.45\text{ V}$ , $I_{OL} = 100\text{ }\mu\text{A}$					0.2	V	
		$V_{CC} = 3.15\text{ V}$ , $I_{OL} = 12\text{ mA}$					0.4		
		$V_{CC} = 3.15\text{ V}$ , $I_{OL} = 24\text{ mA}$					0.5		
	B port	$V_{CC} = 3.15\text{ V to } 3.45\text{ V}$ , $I_{OL} = 100\text{ }\mu\text{A}$					0.2		
		$V_{CC} = 3.15\text{ V}$ , $I_{OL} = 10\text{ mA}$					0.2		
		$V_{CC} = 3.15\text{ V}$ , $I_{OL} = 40\text{ mA}$					0.4		
$V_{CC} = 3.15\text{ V}$ , $I_{OL} = 50\text{ mA}$					0.55				
$I_I$	Control inputs	$V_{CC} = 3.45\text{ V}$ , $V_I = 0\text{ or } 5.5\text{ V}$					$\pm 10$	$\mu\text{A}$	
$I_{OZH}^{(2)}$	A port	$V_{CC} = 3.45\text{ V}$ , $V_O = V_{CC}$					10	$\mu\text{A}$	
	B port	$V_{CC} = 3.45\text{ V}$ , $V_O = 1.5\text{ V}$					10		
$I_{OZL}^{(2)}$	A and B ports	$V_{CC} = 3.45\text{ V}$ , $V_O = \text{GND}$					-10	$\mu\text{A}$	
$I_{BHL}^{(3)}$	A port	$V_{CC} = 3.15\text{ V}$ , $V_I = 0.8\text{ V}$					75	$\mu\text{A}$	
$I_{BHH}^{(4)}$	A port	$V_{CC} = 3.15\text{ V}$ , $V_I = 2\text{ V}$					-75	$\mu\text{A}$	
$I_{BHLO}^{(5)}$	A port	$V_{CC} = 3.45\text{ V}$ , $V_I = 0\text{ to } V_{CC}$					500	$\mu\text{A}$	
$I_{BHHO}^{(6)}$	A port	$V_{CC} = 3.45\text{ V}$ , $V_I = 0\text{ to } V_{CC}$					-500	$\mu\text{A}$	
$I_{CC}$	A or B port	$V_{CC} = 3.45\text{ V}$ , $I_O = 0$ , $V_I$ (A-port or control inputs) = $V_{CC}$ or GND, $V_I$ (B port) = $V_{TT}$ or GND			Outputs high		100	mA	
					Outputs low		100		
					Outputs disabled		100		
$\Delta I_{CC}^{(7)}$		$V_{CC} = 3.45\text{ V}$ , One A-port or control input at $V_{CC} - 0.6\text{ V}$ , Other A-port or control inputs at $V_{CC}$ or GND					1	mA	
$C_i$	Control inputs	$V_I = 3.15\text{ V or } 0$					4.5	5	pF
$C_{io}$	A port	$V_O = 3.15\text{ V or } 0$					7.5	9	pF
	B port	$V_O = 1.5\text{ V or } 0$					7.5	9	

(1) All typical values are at  $V_{CC} = 3.3\text{ V}$ ,  $T_A = 25^\circ\text{C}$ .

(2) For I/O ports, the parameters  $I_{OZH}$  and  $I_{OZL}$  include the input leakage current.

(3) The bus-hold circuit can sink at least the minimum low sustaining current at  $V_{ILmax}$ .  $I_{BHL}$  should be measured after lowering  $V_{IN}$  to GND and then raising it to  $V_{ILmax}$ .

(4) The bus-hold circuit can source at least the minimum high sustaining current at  $V_{IHmin}$ .  $I_{BHH}$  should be measured after raising  $V_{IN}$  to  $V_{CC}$  and then lowering it to  $V_{IHmin}$ .

(5) An external driver must source at least  $I_{BHLO}$  to switch this node from low to high.

(6) An external driver must sink at least  $I_{BHHO}$  to switch this node from high to low.

(7) This is the increase in supply current for each input that is at the specified TTL voltage level, rather than  $V_{CC}$  or GND.

## Hot-Insertion Specifications for A Port

over recommended operating free-air temperature range

PARAMETER	TEST CONDITIONS			MIN	MAX	UNIT
$I_{off}$	$V_{CC} = 0$ ,	BIAS $V_{CC} = 0$ ,	$V_I$ or $V_O = 0\text{ to } 5.5\text{ V}$		10	$\mu\text{A}$
$I_{OZPU}$	$V_{CC} = 0\text{ to } 1.5\text{ V}$ ,	$V_O = 0.5\text{ V to } 3\text{ V}$ ,	$\overline{OE} = 0$		$\pm 30$	$\mu\text{A}$
$I_{OZPD}$	$V_{CC} = 1.5\text{ V to } 0$ ,	$V_O = 0.5\text{ V to } 3\text{ V}$ ,	$\overline{OE} = 0$		$\pm 30$	$\mu\text{A}$

**SN74GTLPH32945**  
**32-BIT LVTTTL-TO-GTLP BUS TRANSCEIVER**

SCES293C–OCTOBER 1999–REVISED JUNE 2005

**Live-Insertion Specifications for B Port**

over recommended operating free-air temperature range

PARAMETER	TEST CONDITIONS			MIN	MAX	UNIT
$I_{off}$	$V_{CC} = 0,$	BIAS $V_{CC} = 0,$	$V_I$ or $V_O = 0$ to 1.5 V		10	$\mu A$
$I_{OZPU}$	$V_{CC} = 0$ to 1.5 V,	BIAS $V_{CC} = 0,$	$V_O = 0.5$ V to 1.5 V, $\overline{OE} = 0$		$\pm 30$	$\mu A$
$I_{OZPD}$	$V_{CC} = 1.5$ V to 0,	BIAS $V_{CC} = 0,$	$V_O = 0.5$ V to 1.5 V, $\overline{OE} = 0$		$\pm 30$	$\mu A$
$I_{CC}$ (BIAS $V_{CC}$ )	$V_{CC} = 0$ to 3.15 V	BIAS $V_{CC} = 3.15$ V to 3.45 V,	$V_O$ (B port) = 0 to 1.5 V		5	mA
	$V_{CC} = 3.15$ V to 3.45 V				10	$\mu A$
$V_O$	$V_{CC} = 0,$	BIAS $V_{CC} = 3.3$ V,	$I_O = 0$	0.95	1.05	V
$I_O$	$V_{CC} = 0,$	BIAS $V_{CC} = 3.15$ V to 3.45 V,	$V_O$ (B port) = 0.6 V	-1		$\mu A$

**Switching Characteristics**

over recommended ranges of supply voltage and operating free-air temperature,  
 $V_{TT} = 1.5$  V and  $V_{REF} = 1$  V for GTLP (see Figure 1)

PARAMETER	FROM (INPUT)	TO (OUTPUT)	MIN	TYP <sup>(1)</sup>	MAX	UNIT
$t_{PLH}$	A	B	2.1		6.3	ns
$t_{PHL}$			2.1		6.3	
$t_{en}$	$\overline{OE}$	B	2		6.9	ns
$t_{dis}$			2		6.9	
$t_r$	Rise time, B outputs (20% to 80%)		2.5			ns
$t_f$	Fall time, B outputs (80% to 20%)		2.1			ns
$t_{PLH}$	B	A	2.1		5.3	ns
$t_{PHL}$			2.1		5.3	
$t_{en}$	$\overline{OE}$	A	0.3		5.7	ns
$t_{dis}$			0.3		5.7	

(1) All typical values are at  $V_{CC} = 3.3$  V,  $T_A = 25^\circ C$ .



PARAMETER MEASUREMENT INFORMATION

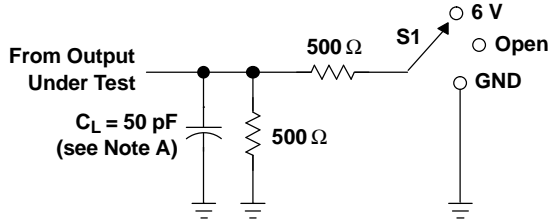

LOAD CIRCUIT FOR A OUTPUTS

TEST	S1
$t_{PLH}/t_{PHL}$	Open
$t_{PLZ}/t_{PZL}$	6 V
$t_{PHZ}/t_{PZH}$	GND

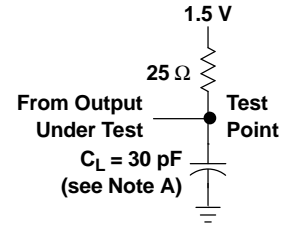

LOAD CIRCUIT FOR B OUTPUTS

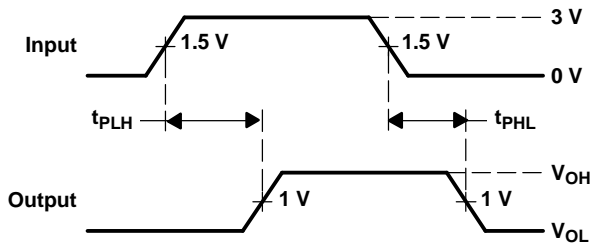

VOLTAGE WAVEFORMS  
PROPAGATION DELAY TIMES  
(A port to B port)

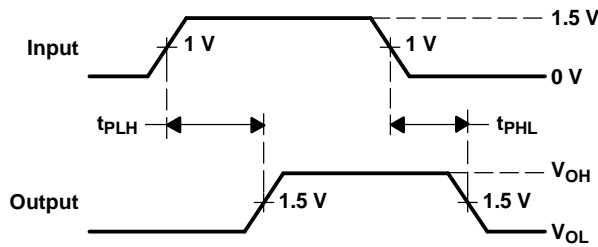

VOLTAGE WAVEFORMS  
PROPAGATION DELAY TIMES  
(B port to A port)

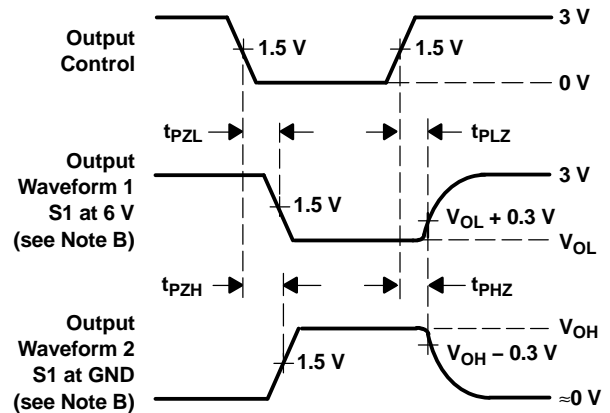

VOLTAGE WAVEFORMS  
ENABLE AND DISABLE TIMES  
(A port)

- NOTES: A.  $C_L$  includes probe and jig capacitance.  
 B. Waveform 1 is for an output with internal conditions such that the output is low, except when disabled by the output control. Waveform 2 is for an output with internal conditions such that the output is high, except when disabled by the output control.  
 C. All input pulses are supplied by generators having the following characteristics: PRR  $\approx$  10 MHz,  $Z_O = 50 \Omega$ ,  $t_r \approx 2$  ns,  $t_f \approx 2$  ns.  
 D. The outputs are measured one at a time, with one transition per measurement.

Figure 1. Load Circuits and Voltage Waveforms

### Distributed-Load Backplane Switching Characteristics

The preceding switching characteristics table shows the switching characteristics of the device into a lumped load (Figure 1). However, the designer's backplane application probably is a distributed load. The physical representation is shown in Figure 2. This backplane, or distributed load, can be approximated closely to a resistor inductance capacitance (RLC) circuit, as shown in Figure 3. This device has been designed for optimum performance in this RLC circuit. The following switching characteristics table shows the switching characteristics of the device into the RLC load, to help the designer better understand the performance of the GTLP device in this typical backplane. See [www.ti.com/sc/gtlp](http://www.ti.com/sc/gtlp) for more information.

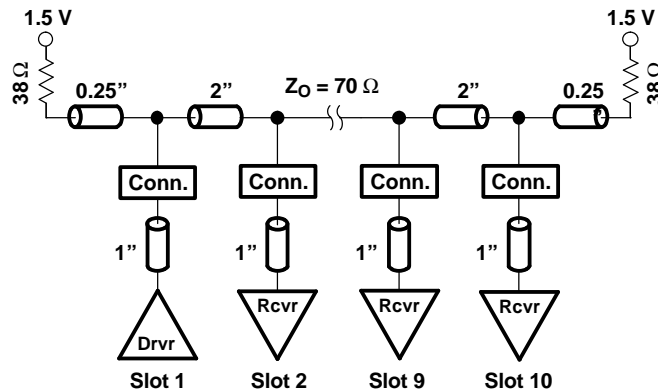

Figure 2. Medium-Drive Test Backplane

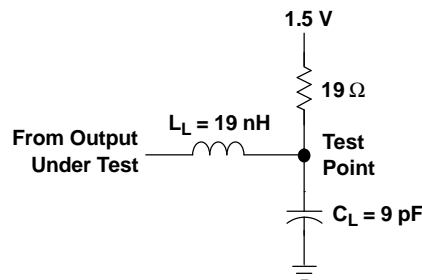

Figure 3. Medium-Drive RLC Network

### Switching Characteristics

over recommended ranges of supply voltage and operating free-air temperature,  
 $V_{TT} = 1.5\text{ V}$  and  $V_{REF} = 1\text{ V}$  for GTLP (see Figure 3)

PARAMETER	FROM (INPUT)	TO (OUTPUT)	TYP <sup>(1)</sup>	UNIT
$t_{PLH}$	A	B	4.3	ns
$t_{PHL}$			4.3	
$t_{en}$	$\overline{OE}$	B	5	ns
$t_{dis}$			4.4	
$t_r$	Rise time, B outputs (20% to 80%)		1	ns
$t_f$	Fall time, B outputs (80% to 20%)		2	ns

(1) All typical values are at  $V_{CC} = 3.3\text{ V}$ ,  $T_A = 25^\circ\text{C}$ . All values are derived from TI-SPICE models.

**PACKAGING INFORMATION**

Orderable Device	Status <sup>(1)</sup>	Package Type	Package Drawing	Pins	Package Qty	Eco Plan <sup>(2)</sup>	Lead/Ball Finish	MSL Peak Temp <sup>(3)</sup>
SN74GTLPH32945KR	NRND	LFBGA	GKE	96	1000	TBD	SNPB	Level-3-220C-168 HR
SN74GTLPH32945ZKER	ACTIVE	LFBGA	ZKE	96	1000	Green (RoHS & no Sb/Br)	SNAGCU	Level-3-260C-168 HR

<sup>(1)</sup> The marketing status values are defined as follows:

**ACTIVE:** Product device recommended for new designs.

**LIFEBUY:** TI has announced that the device will be discontinued, and a lifetime-buy period is in effect.

**NRND:** Not recommended for new designs. Device is in production to support existing customers, but TI does not recommend using this part in a new design.

**PREVIEW:** Device has been announced but is not in production. Samples may or may not be available.

**OBSELETE:** TI has discontinued the production of the device.

<sup>(2)</sup> Eco Plan - The planned eco-friendly classification: Pb-Free (RoHS), Pb-Free (RoHS Exempt), or Green (RoHS & no Sb/Br) - please check <http://www.ti.com/productcontent> for the latest availability information and additional product content details.

**TBD:** The Pb-Free/Green conversion plan has not been defined.

**Pb-Free (RoHS):** TI's terms "Lead-Free" or "Pb-Free" mean semiconductor products that are compatible with the current RoHS requirements for all 6 substances, including the requirement that lead not exceed 0.1% by weight in homogeneous materials. Where designed to be soldered at high temperatures, TI Pb-Free products are suitable for use in specified lead-free processes.

**Pb-Free (RoHS Exempt):** This component has a RoHS exemption for either 1) lead-based flip-chip solder bumps used between the die and package, or 2) lead-based die adhesive used between the die and leadframe. The component is otherwise considered Pb-Free (RoHS compatible) as defined above.

**Green (RoHS & no Sb/Br):** TI defines "Green" to mean Pb-Free (RoHS compatible), and free of Bromine (Br) and Antimony (Sb) based flame retardants (Br or Sb do not exceed 0.1% by weight in homogeneous material)

<sup>(3)</sup> MSL, Peak Temp. -- The Moisture Sensitivity Level rating according to the JEDEC industry standard classifications, and peak solder temperature.

**Important Information and Disclaimer:**The information provided on this page represents TI's knowledge and belief as of the date that it is provided. TI bases its knowledge and belief on information provided by third parties, and makes no representation or warranty as to the accuracy of such information. Efforts are underway to better integrate information from third parties. TI has taken and continues to take reasonable steps to provide representative and accurate information but may not have conducted destructive testing or chemical analysis on incoming materials and chemicals. TI and TI suppliers consider certain information to be proprietary, and thus CAS numbers and other limited information may not be available for release.

In no event shall TI's liability arising out of such information exceed the total purchase price of the TI part(s) at issue in this document sold by TI to Customer on an annual basis.

**TAPE AND REEL INFORMATION**



**QUADRANT ASSIGNMENTS FOR PIN 1 ORIENTATION IN TAPE**



\*All dimensions are nominal

Device	Package Type	Package Drawing	Pins	SPQ	Reel Diameter (mm)	Reel Width W1 (mm)	A0 (mm)	B0 (mm)	K0 (mm)	P1 (mm)	W (mm)	Pin1 Quadrant
SN74GTLPH32945KR	LFBGA	GKE	96	1000	330.0	24.4	5.7	13.7	2.0	8.0	24.0	Q1
SN74GTLPH32945ZKER	LFBGA	ZKE	96	1000	330.0	24.4	5.7	13.7	2.0	8.0	24.0	Q1

**TAPE AND REEL BOX DIMENSIONS**



\*All dimensions are nominal

Device	Package Type	Package Drawing	Pins	SPQ	Length (mm)	Width (mm)	Height (mm)
SN74GTLPH32945KR	LFBGA	GKE	96	1000	346.0	346.0	41.0
SN74GTLPH32945ZKER	LFBGA	ZKE	96	1000	346.0	346.0	41.0

GKE (R-PBGA-N96)

PLASTIC BALL GRID ARRAY

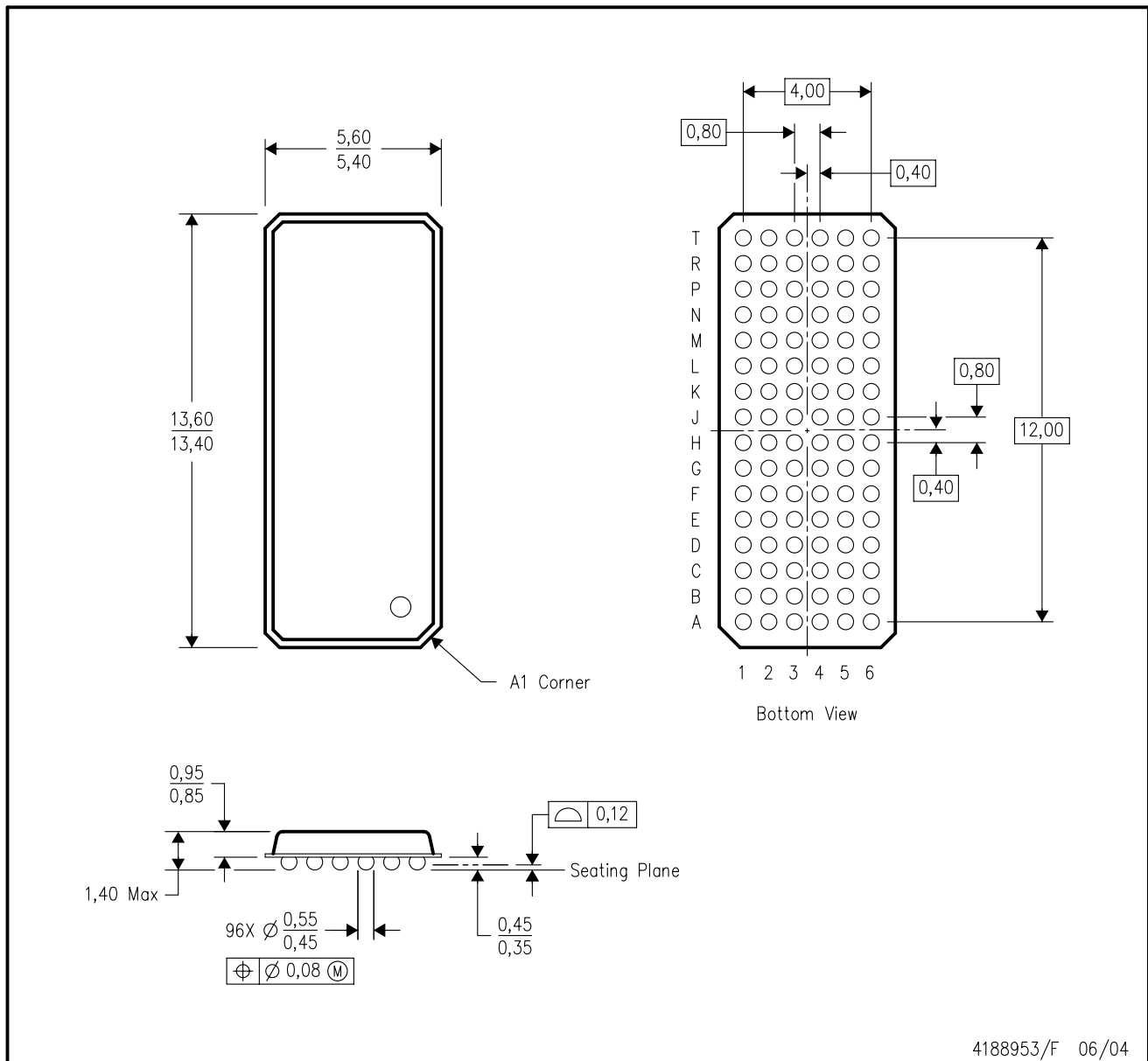

- NOTES:
- A. All linear dimensions are in millimeters.
  - B. This drawing is subject to change without notice.
  - C. Falls within JEDEC MO-205 variation CC.
  - D. This package is tin-lead (SnPb). Refer to the 96 ZKE package (drawing 4204493) for lead-free.

ZKE (R-PBGA-N96)

PLASTIC BALL GRID ARRAY

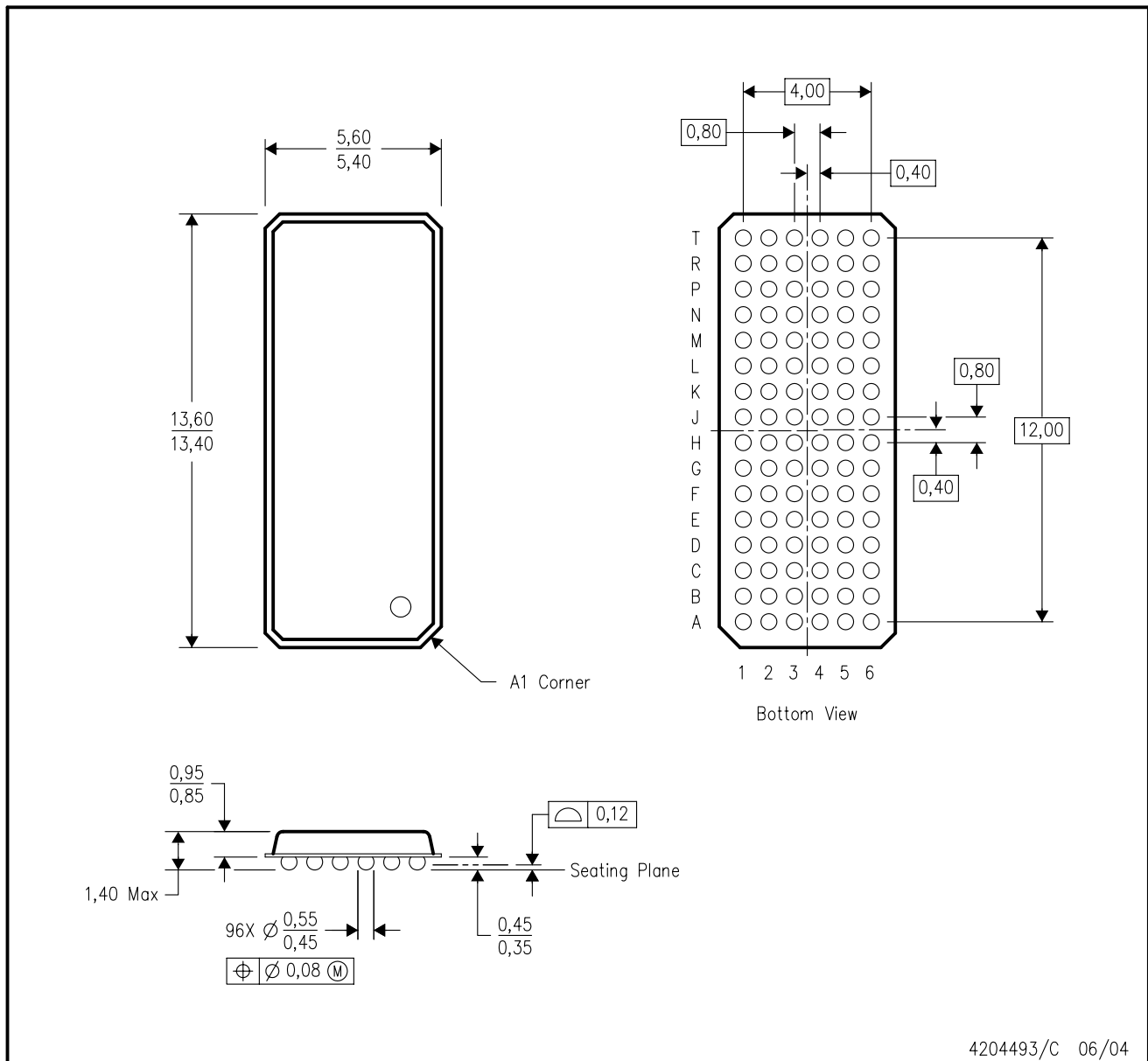

- NOTES:
- A. All linear dimensions are in millimeters.
  - B. This drawing is subject to change without notice.
  - C. Falls within JEDEC MO-205 variation CC.
  - D. This package is lead-free. Refer to the 96 GKE package (drawing 4188953) for tin-lead (SnPb).



## IMPORTANT NOTICE

Texas Instruments Incorporated and its subsidiaries (TI) reserve the right to make corrections, modifications, enhancements, improvements, and other changes to its products and services at any time and to discontinue any product or service without notice. Customers should obtain the latest relevant information before placing orders and should verify that such information is current and complete. All products are sold subject to TI's terms and conditions of sale supplied at the time of order acknowledgment.

TI warrants performance of its hardware products to the specifications applicable at the time of sale in accordance with TI's standard warranty. Testing and other quality control techniques are used to the extent TI deems necessary to support this warranty. Except where mandated by government requirements, testing of all parameters of each product is not necessarily performed.

TI assumes no liability for applications assistance or customer product design. Customers are responsible for their products and applications using TI components. To minimize the risks associated with customer products and applications, customers should provide adequate design and operating safeguards.

TI does not warrant or represent that any license, either express or implied, is granted under any TI patent right, copyright, mask work right, or other TI intellectual property right relating to any combination, machine, or process in which TI products or services are used. Information published by TI regarding third-party products or services does not constitute a license from TI to use such products or services or a warranty or endorsement thereof. Use of such information may require a license from a third party under the patents or other intellectual property of the third party, or a license from TI under the patents or other intellectual property of TI.

Reproduction of TI information in TI data books or data sheets is permissible only if reproduction is without alteration and is accompanied by all associated warranties, conditions, limitations, and notices. Reproduction of this information with alteration is an unfair and deceptive business practice. TI is not responsible or liable for such altered documentation. Information of third parties may be subject to additional restrictions.

Resale of TI products or services with statements different from or beyond the parameters stated by TI for that product or service voids all express and any implied warranties for the associated TI product or service and is an unfair and deceptive business practice. TI is not responsible or liable for any such statements.

TI products are not authorized for use in safety-critical applications (such as life support) where a failure of the TI product would reasonably be expected to cause severe personal injury or death, unless officers of the parties have executed an agreement specifically governing such use. Buyers represent that they have all necessary expertise in the safety and regulatory ramifications of their applications, and acknowledge and agree that they are solely responsible for all legal, regulatory and safety-related requirements concerning their products and any use of TI products in such safety-critical applications, notwithstanding any applications-related information or support that may be provided by TI. Further, Buyers must fully indemnify TI and its representatives against any damages arising out of the use of TI products in such safety-critical applications.

TI products are neither designed nor intended for use in military/aerospace applications or environments unless the TI products are specifically designated by TI as military-grade or "enhanced plastic." Only products designated by TI as military-grade meet military specifications. Buyers acknowledge and agree that any such use of TI products which TI has not designated as military-grade is solely at the Buyer's risk, and that they are solely responsible for compliance with all legal and regulatory requirements in connection with such use.

TI products are neither designed nor intended for use in automotive applications or environments unless the specific TI products are designated by TI as compliant with ISO/TS 16949 requirements. Buyers acknowledge and agree that, if they use any non-designated products in automotive applications, TI will not be responsible for any failure to meet such requirements.

Following are URLs where you can obtain information on other Texas Instruments products and application solutions:

### Products

Amplifiers	<a href="http://amplifier.ti.com">amplifier.ti.com</a>
Data Converters	<a href="http://dataconverter.ti.com">dataconverter.ti.com</a>
DSP	<a href="http://dsp.ti.com">dsp.ti.com</a>
Clocks and Timers	<a href="http://www.ti.com/clocks">www.ti.com/clocks</a>
Interface	<a href="http://interface.ti.com">interface.ti.com</a>
Logic	<a href="http://logic.ti.com">logic.ti.com</a>
Power Mgmt	<a href="http://power.ti.com">power.ti.com</a>
Microcontrollers	<a href="http://microcontroller.ti.com">microcontroller.ti.com</a>
RFID	<a href="http://www.ti-rfid.com">www.ti-rfid.com</a>
RF/IF and ZigBee® Solutions	<a href="http://www.ti.com/lprf">www.ti.com/lprf</a>

### Applications

Audio	<a href="http://www.ti.com/audio">www.ti.com/audio</a>
Automotive	<a href="http://www.ti.com/automotive">www.ti.com/automotive</a>
Broadband	<a href="http://www.ti.com/broadband">www.ti.com/broadband</a>
Digital Control	<a href="http://www.ti.com/digitalcontrol">www.ti.com/digitalcontrol</a>
Medical	<a href="http://www.ti.com/medical">www.ti.com/medical</a>
Military	<a href="http://www.ti.com/military">www.ti.com/military</a>
Optical Networking	<a href="http://www.ti.com/opticalnetwork">www.ti.com/opticalnetwork</a>
Security	<a href="http://www.ti.com/security">www.ti.com/security</a>
Telephony	<a href="http://www.ti.com/telephony">www.ti.com/telephony</a>
Video & Imaging	<a href="http://www.ti.com/video">www.ti.com/video</a>
Wireless	<a href="http://www.ti.com/wireless">www.ti.com/wireless</a>

Mailing Address: Texas Instruments, Post Office Box 655303, Dallas, Texas 75265  
Copyright © 2008, Texas Instruments Incorporated